

NOTICE OF MEETING
FORT BEND COUNTY COMMISSIONERS COURT
7TH FLOOR, WM. B. TRAVIS BUILDING, RICHMOND, TEXAS
TUESDAY, OCTOBER 12, 1999
1:00 O'CLOCK P.M.

AGENDA

- 1 Call to Order
- 2 Invocation and Pledge of Allegiance by Commissioner Patterson
- 3 Approve minutes of meeting of October 5, 1999
- 4 Announcements and Public Comments
- 5 Approve line item transfers in budgets and funds
 - A Constable, Pct 2 (024) – Transfer \$1,188 from Contract Deputy to Conf/Travel
 - B Constable, Pct 3 (025) – Transfer \$ 1,400 from Uniforms into Property/Equipment
 - C Constable, Pct 3 (025) – Transfer \$400 from Uniforms into Fees/Services
 - D Veterans Services (035) – Transfer \$25 from Automobiles to Rentals
 - E MIS (036) – Transfer \$5,000 from Fees/Service into Conf/Travel
 - F Engineering (043) – Transfer \$4,326 14 into Household Hazardous Waste
 - G Non-Departmental (045) – Transfer ~~\$2,721~~ from Constable, Pct 2 Contract Deputy into Non Departmental Contingency ~~\$1,533~~
 - H Non-Departmental (045) – Transfer \$100,000 from Contingency into Non Department Fees/Services
 - I Drainage District (051) – Transfer \$2,000 from Repairs into Permanent Improvements
 - J County Court at Law #3 – Transfer \$20,000 from Contingency into Fees/Services
 - K Commissioner, Pct #2 – Transfer \$1,500 from Fees/Services into Conf/Travel
 - L Road & Bridge (075) – Transfer \$15,000 from Fees/Services into Road Signs and transfer \$50,000 from Salaries into Overtime
 - M Community Development (101) – Transfer \$20,000 from Community Development Contingency and \$18,343 from Permanent Improvement into Pct 1 Community Center Construction Fund

NOTICE
Policy of Non-Discrimination on the Basis of Disability

Fort Bend County does not discriminate on the basis of disability in the admission or access to or treatment or employment in, its programs or activities

ADA Coordinator Risk/Management Insurance Dept 7th Floor Travis Building Richmond Texas 777469 phone 281-341 8618 has been designated to coordinate compliance with the non discrimination requirements in Section 35 107 of the Department of Justice regulations * Information concerning the provisions of the Americans with Disabilities Act, and the rights provided thereunder are available from the ADA coordinator

- 6 Approve out-of-state travel requests for County personnel and enter into record the out-of-state travel requests for elected officials
- A Library – Molly Krukewitt and Sandy VanLandingham to Denver, Colorado, November 9-14, 1999 (Fund #0701 to be reimbursed by grant)

CONSENT AGENDA ITEMS 7-12:

7. **COMMISSIONER, PCT. 3:** Approve request for annexation of land into North Mission Glen Municipal Utility District.

8. **ENGINEERING:**

- A. Approve application from GTE to bury cable along Juliff-Manville Road, Pct. 2.
- B. Approve application from Southwestern Bell Telephone Company to bury cable along Skinner Road, Pct. 3.
- C. Set public hearing for acceptance of traffic control plan for Avenue "E" Stafford Area, 5th Street Stafford Area, and Dove Country Subdivision, ~~Pct. 1~~ and Pct. 3. (November 9, 1999 at 1:30 pm)
- Pct 2
D. Set public hearing for acceptance of traffic control plan for Lexington Settlement Subdivision, Pct. 3. (November 9, 1999 at 1:30 pm)
- E. Approve the plat for Texana Plantation, Section 3, Pct. 3.
- F. Approve the plat for Sienna Village of Waters Lake, Section 7-A, Pct. 2.
- G. Approve the plat for Greatwood Wood Creek, Pct. 1.
- H. Approve the plat for Greatwood Fairview, Pct. 1.
- I. Approve the plat for Greatwood Stonebridge, Pct. 1.
- J. Approve the plat for Greatwood Brooks Mills, Pct. 1.
- K. Approve the plat for Greatwood Shadow Bend Drive, Winding Brook East Drive and Winding Brook West Drive Street Dedication, Pct. 1.

9. **EXTENSION SERVICES:** Approve payment of Invoice #5 for Architectural Services to Don A. Hartfiel for the FBC Agriculture Center. (Fund: 202-045-2026)

10. **RISK MANAGEMENT:**

- A. Approve the 2000 annual letter of exemption for the Health Insurance Portability and Accountability Act of 1996.
- B. Authorize payments for damages to County vehicles, non-County vehicles, and County property. (Fund: 403-068-0682-1010 for \$3,124 and Fund: 403-068-0682 7100 for \$2,227.80)

11. **TAX ASSESSOR/COLLECTOR:**

- A. Approve the Resale of Property taken under Cause No. 71,457; Fort Bend ISD vs. Edward Austin.
- B. Approve the Resale of Property taken under Cause No. 80,176; Lamar CISD vs. Louisa Munoz, et. al.

12. **TREASURER: Approve payment of monthly bills for the Fort Bend County Flood Control Water Supply Corporation in the amount of \$80,458.84. (Fund: 265-006-2640-4010)**
-
- 14 COUNTY TREASURER Discuss and consider taking action on Fort Bend County's Employer Contribution Rate and Annually Determined Contribution Rate Plan for 2000 for the Texas County and District Retirement System
- 15 1 30 p m – Hold public hearings on the following items
- ✓A To discuss Senate Bill 712 regarding Mobile Home Park Development
 - ✓B To set new public hearing date to discuss and consider taking action on Senate Bill 712 regarding Mobile Home Park Development (October 26, 1999 at 1 30 pm)
 - ✓C Hold Public Hearing to discuss the Proposed 2000 Budget for Fort Bend County as stated in the Local Government Code 111 0675
 - ✓D Discuss and consider accepting the 2000 salary schedule for county elected officials and approved positions for FY 2000
 - ✓E Discuss and consider accepting the 2000 Proposed Budget for Fort Bend County
- 16 COUNTY JUDGE
- ✓A Discuss and consider approving \$10,000 to be paid to Texana MHMR to assist in the payment of a consultant hired to recruit an Executive Director for Texana (Fund 010-045-4010)
 - B Discuss and consider accepting Resolution to nominate candidates for the Central Appraisal District Board of Directors for the term 2000-2001
- 17 COUNTY ATTORNEY Discuss and consider granting permission to Rosenberg Revitalization Association for use of parking lot at Fort Bend County -Rosenberg Annex for annual Christmas Magic event parking, Saturday November 27 1999
- 18 COMMUNITY DEVELOPMENT
- A Discuss and approve Change Order No 1 from Bass Construction for construction of the Pct 1 Community Center Building This is a reduction in the Contract Sum of \$2,007 and an increase in contract time of 137 days Contract awarded to Bass by Commissioner Court 3 2/99 FBC Bid #99-025 (Fund 840-101-8040)
 - B Discuss and approve Change Order No 2 from Bass Construction for construction of the Pct 1 Community Center Building This is an increase in contract sum by \$40,349 40 (Fund 840-101-8040)
- 19 ELECTIONS ADMINISTRATION Discuss and consider adopting new boundary lines for Precinct 3049 effective January 1, 2000

20 ENGINEERING

- A Discuss and consider approving the agreement between the State of Texas, acting through the Texas Department of Transportation and Fort Bend County FBC will initiate a preliminary engineering study for the proposed Fairgrounds Park & Ride and be partially reimbursed by Federal Funds
- B Discuss and consider adopting a resolution for the Fairgrounds Park & Ride committing Fort Bend County funds of \$62,500 for this project Federal reimbursement is \$50,000 (Fund TBD)

21 PURCHASING

- A Authorize advertising for bids for the following
 - 1) Tires and tubes
 - 2) Photographic supplies
 - 3) Traffic signs/posts/supplies
 - 4) Oils and lubricants
 - 5) Weed, brush and insect control material
- B Authorize advertising for statements of qualification for engineering services for the Park & Ride at Fairgrounds
- C Consider taking action on Bid #99-079 purchasing of pre-engineered building
- D Consider renewing the term contract for hauling and disposal of condensate/leachate – Bid #99-005 #99-001
- E Consider granting exemption to competitive bid process as authorized by 262 024 TLGC for a professional service – architectural service for Courthouse Rehabilitation Master Plan as required before submitting an Historical grant application Not to exceed \$25,000 (Fund TBD)

22 Approve bills

23. **Meet in Closed Session** to discuss the following matters

- A. **Personnel matters**
 - 1) District Attorney
 - 2) Juvenile Probation
- as authorized by TX Gov Code, Sec 551/074

24 Reconvene Open Session and consider taking action on the following Closed Session matters

- A. **Personnel matters**
 - 1) District Attorney
 - 2) Juvenile Probation
- as authorized by TX Gov Code, Sec 551/074

25 Adjournment

In the event any of the foregoing items are not covered in the time allocated on the date of this agenda, the County may order a continuance for the next day until the discussion is completed on all items

James C. Adolphus, County Judge

Notice of meeting/agenda posted at William B Travis Building, Courthouse & Jane Long Annex, Richmond, Texas on Friday, October 8, 1999 by Sharon McManon

FILED FOR RECORD

TIME 11:28 AM

OCT 07 1999



County Clerk Fort Bend Co Texas

**NOTICE OF MEETING
FORT BEND PARKWAY ROAD DISTRICT
BOARD OF DIRECTORS
7th FLOOR, WM. B. TRAVIS BUILDING, RICHMOND, TEXAS
TUESDAY, OCTOBER 12, 1999
1:30 O'CLOCK P.M.**

AGENDA

- 1 Call to Order
- 2 Hold public hearing to discuss the 2000 Budget for the Fort Bend Parkway Road District
- 3 Discuss and consider accepting the 2000 Proposed Budget for the Fort Bend Parkway Road District
- 4 Adjournment

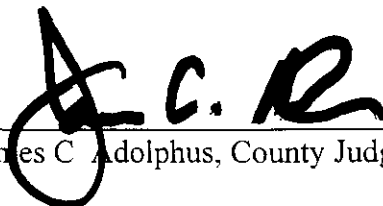
In the event any of the foregoing items are not covered in the time allocated on the date of this agenda, the County may order a continuance for the next day until the discussion is completed on all items



James C. Adolphus, County Judge

Notice of meeting/agenda posted at William B Travis Building, Courthouse & Jane Long Annex, Richmond, Texas on Friday, October 8, 1999 by Sharon Mc Mahon

NOTICE
Policy of Non Discrimination on the Basis of Disability

Fort Bend County does not discriminate on the basis of disability in the admission or access to or treatment or employment in its programs or activities

ADA Coordinator Risk/Management Insurance Dept. 7th Floor Travis Building Richmond Texas 777469 phone 281 341 8618 has been designated to coordinate compliance with the non-discrimination requirements in Section 35 107 of the Department of Justice regulations * Information concerning the provisions of the Americans with Disabilities Act and the rights provided thereunder are available from the ADA coordinator

FILED FOR RECORD

TIME 11 28 A.M.

OCT 07 1999

County Clerk Fort Bend Co. Texas

**APPROVAL OF MINUTES
COMMISSIONERS COURT
FORT BEND COUNTY**

I, Dianne Wilson, duly elected County Clerk and Clerk of Court, Fort Bend County, Texas do hereby submit the Official Minutes of Commissioners Court held on the 12TH day of OCTOBER, 1999

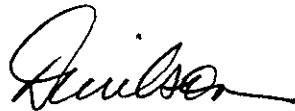

DIANNE WILSON, COUNTY CLERK

Now, therefore, be it resolved upon the motion of Commissioner Meyers seconded by Patterson, duly put and carried, it is ordered to accept for record the attached minutes approved on this the 26TH day of OCTOBER, 1999.



JIM ADOLPHUS, COUNTY JUDGE

Approved Minutes

MINUTES

BE IT REMEMBERED, That on this 12TH DAY of OCTOBER, 1999 Commissioners Court of Fort Bend County, Texas, met at a scheduled meeting with the following present

JAMES C ADOLPHUS	COUNTY JUDGE
R L "BUD" O'SHIELES	COMMISSIONER PRECINCT 1
GRADY PRESTAGE	COMMISSIONER PRECINCT 2
ANDY MEYERS	COMMISSIONER PRECINCT 3
JAMES PATTERSON	COMMISSIONER PRECINCT 4
DIANNE WILSON	COUNTY CLERK

When the following were heard and the following orders passed

1. Call to Order.

Call to Order by Judge Adolphus at 1 03 p m

2. Invocation and Pledge of Allegiance by Commissioner Patterson.

Invocation and Pledge of Allegiance by Commissioner Patterson

3. Approve minutes of meeting of October 5, 1999.

Moved by Commissioner Meyers, Seconded by Commissioner Patterson, duly put and unanimously carried (5-0), it is ordered to approve minutes of meeting of October 5, 1999

Judge Adolphus	yes	Commissioner Meyers	yes
Commissioner O'Shieles	yes	Commissioner Patterson	yes
Commissioner Prestage	yes		

4. Announcements and Public Comments.

Judge Adolphus presented proclamations

- National Family Community Education Week - October 10 - October 16
- Breast Cancer Awareness Month - October

- 5. **Approve line item transfers in budgets and funds.**
 - A. **Constable, Pct. 2 (024) – Transfer \$1,188 from Contract Deputy to Conf/Travel.**
 - B. **Constable, Pct. 3 (025) – Transfer \$ 1,400 from Uniforms into Property/Equipment.**
 - C. **Constable, Pct. 3 (025) – Transfer \$400 from Uniforms into Fees/Services.**
 - D. **Veterans Services (035) – Transfer \$25 from Automobiles to Rentals.**
 - E. **MIS (036) – Transfer \$5,000 from Fees/Service into Conf/Travel.**
 - F. **Engineering (043) – Transfer \$4,326.14 into Household Hazardous Waste.**
 - G. **Non Departmental (045) – Transfer \$1,533 from Constable, Pct. 2 Contract Deputy into Non Departmental Contingency.**
 - H. **Non Departmental (045) – Transfer \$100,000 from Contingency into Non Department Fees/Services.**
 - I. **Drainage District (051) – Transfer \$2,000 from Repairs into Permanent Improvements.**
 - J. **County Court at Law #3 – Transfer \$20,000 from Contingency into Fees/Services.**
 - K. **Commissioner, Pct. #2 – Transfer \$1,500 from Fees/Services into Conf/Travel.**
 - L. **Road & Bridge (075) – Transfer \$15,000 from Fees/Services into Road Signs and transfer \$50,000 from Salaries into Overtime.**
 - M. **Community Development (101) – Transfer \$20,000 from Community Development Contingency and \$18,343 from Permanent Improvement into Pct. 1 Community Center Construction Fund.**

Moved by Commissioner Prestage, Seconded by Commissioner Patterson, duly put and unanimously carried (5-0), it is ordered to approve line item transfers for items 5(a) through 5(m) as presented by Jim Edwards, Budget Officer

Judge Adolphus	yes	Commissioner Meyers	yes
Commissioner O’Shieles	yes	Commissioner Patterson	yes
Commissioner Prestage	yes		

- 6. **Approve out-of-state travel requests for County personnel and enter into record the out-of-state travel requests for elected officials.**
 - A. **Library – Molly Krukewitt and Sandy VanLandingham to Denver, Colorado, November 9-14, 1999 (Fund: #0701 to be reimbursed by grant).**

Moved by Commissioner Patterson, Seconded by Commissioner Prestage, duly put and unanimously carried (5-0), it is ordered to approve out of state travel request for LIBRARY

Judge Adolphus	yes	Commissioner Meyers	yes
Commissioner O’Shieles	yes	Commissioner Patterson	yes
Commissioner Prestage	yes		

CONSENT AGENDA ITEMS 7-12:

7. COMMISSIONER, PCT. 3: Approve request for annexation of land into North Mission Glen Municipal Utility District.

Moved by Commissioner Prestage, Seconded by Commissioner O'Shieles, duly put and unanimously carried (5-0), it is ordered to approve request for annexation of land into North Mission Glen Municipal Utility District

Judge Adolphus	yes	Commissioner Meyers	yes
Commissioner O'Shieles	yes	Commissioner Patterson	yes
Commissioner Prestage	yes		

8. ENGINEERING:

- A. Approve application from GTE to bury cable along Juliff-Manville Road, Pct. 2.**
- B. Approve application from Southwestern Bell Telephone Company to bury cable along Skinner Road, Pct. 3.**
- C. Set public hearing for acceptance of traffic control plan for Avenue "E" Stafford Area, 5th Street Stafford Area, and Dove Country Subdivision, Pct. 2 and Pct. 3. (November 9, 1999 at 1:30 pm)**
- D. Set public hearing for acceptance of traffic control plan for Lexington Settlement Subdivision, Pct. 3. (November 9, 1999 at 1:30 pm)**
- E. Approve the plat for Texana Plantation, Section 3, Pct. 3.**
- F. Approve the plat for Sienna Village of Waters Lake, Section 7-A, Pct. 2.**
- G. Approve the plat for Greatwood Wood Creek, Pct. 1.**
- H. Approve the plat for Greatwood Fairview, Pct. 1.**
- I. Approve the plat for Greatwood Stonebridge, Pct. 1.**
- J. Approve the plat for Greatwood Brooks Mills, Pct. 1.**
- K. Approve the plat for Greatwood Shadow Bend Drive, Winding Brook East Drive and Winding Brook West Drive Street Dedication, Pct. 1.**

Moved by Commissioner Prestage, Seconded by Commissioner O'Shieles, duly put and unanimously carried (5-0), it is ordered to approve items 8(a) through 8(f) for Engineering

Pass on items 8(g) through 8(k)

Judge Adolphus	yes	Commissioner Meyers	yes
Commissioner O'Shieles	yes	Commissioner Patterson	yes
Commissioner Prestage	yes		

OCTOBER 12, 1999

9. EXTENSION SERVICES: Approve payment of Invoice #5 for Architectural Services to Don A. Hartfield for the FBC Agriculture Center. (Fund: 202-045-2026)

Moved by Commissioner Prestage, Seconded by Commissioner O'Shieles, duly put and unanimously carried (5-0), it is ordered to approve payment of Invoice #5 for Architectural Services to Don A Hartfield for the FBC Agriculture Center (Fund 202-045-2026)

Judge Adolphus	yes	Commissioner Meyers	yes
Commissioner O'Shieles	yes	Commissioner Patterson	yes
Commissioner Prestage	yes		

10. RISK MANAGEMENT:

A. Approve the 2000 annual letter of exemption for the Health Insurance Portability and Accountability Act of 1996.

B. Authorize payments for damages to County vehicles, non-County vehicles, and County property. (Fund: 403-068-0682-1010 for \$3,124 and Fund: 403-068-0682 7100 for \$2,227.80)

Moved by Commissioner Prestage, Seconded by Commissioner O'Shieles, duly put and unanimously carried (5-0), it is ordered to approve items 10(a) and 10(b) for Risk Management

Judge Adolphus	yes	Commissioner Meyers	yes
Commissioner O'Shieles	yes	Commissioner Patterson	yes
Commissioner Prestage	yes		

11. TAX ASSESSOR/COLLECTOR:

A. Approve the Resale of Property taken under Cause No. 71,457; Fort Bend ISD vs. Edward Austin.

B. Approve the Resale of Property taken under Cause No. 80,176; Lamar CISD vs. Louisa Munoz, et. al.

Moved by Commissioner Prestage, Seconded by Commissioner O'Shieles, duly put and unanimously carried (5-0), it is ordered to approve items 11(a) and 11(b) for Tax Assessor/Collector

Judge Adolphus	yes	Commissioner Meyers	yes
Commissioner O'Shieles	yes	Commissioner Patterson	yes
Commissioner Prestage	yes		

- 12. **TREASURER: Approve payment of monthly bills for the Fort Bend County Flood Control Water Supply Corporation in the amount of \$80,458.84. (Fund: 265-006-2640-4010)**

Moved by Commissioner Prestage, Seconded by Commissioner O'Shieles, duly put and unanimously carried (5-0), it is ordered to approve payment of monthly bills for the Fort Bend County Flood Control Water Supply Corporation in the amount of \$80,458 84 (Fund 265-006-2640-4010)

Table with 4 columns: Name, Response, Name, Response. Rows include Judge Adolphus, Commissioner O'Shieles, Commissioner Prestage, Commissioner Meyers, and Commissioner Patterson.

Item #13 not listed on agenda.

- 14. **COUNTY TREASURER: Discuss and consider taking action on Fort Bend County's Employer Contribution Rate and Annually Determined Contribution Rate Plan for 2000 for the Texas County and District Retirement System.**

Pass

- 15. **1:30 p.m. – Hold public hearings on the following items:**
A. To discuss Senate Bill 712 regarding Mobile Home Park Development.

No public comments

- B. To set new public hearing date to discuss and consider taking action on Senate Bill 712 regarding Mobile Home Park Development. (October 26, 1999 at 1:30 pm)**

Moved by Commissioner Prestage, Seconded by Commissioner Meyers, duly put and unanimously carried (5-0), it is ordered to set public hearing new public hearing date to discuss and consider taking action on Senate Bill 712 regarding Mobile Home Park Development (October 26, 1999 at 1 30 pm)

Table with 4 columns: Name, Response, Name, Response. Rows include Judge Adolphus, Commissioner O'Shieles, Commissioner Prestage, Commissioner Meyers, and Commissioner Patterson.

- C. Hold Public Hearing to discuss the Proposed 2000 Budget for Fort Bend County as stated in the Local Government Code 111.0675.**

Mayor Gammel of Simonton, requested that a river gauge above Simonton be included in the 2000 budget

item #15 continued - hold public hearing on the following items:

D. Discuss and consider accepting the 2000 salary schedule for county elected officials and approved positions for FY 2000.

Moved by Commissioner Prestage, Seconded by Commissioner O'Shieles, to approve 3% pay increase for all elected officials as per the published salary structure

Judge Adolphus	yes	Commissioner Meyers	yes
Commissioner O'Shieles	yes	Commissioner Patterson	yes
Commissioner Prestage	yes		

Pass positions for FY 2000 until October 26

E. Discuss and consider accepting the 2000 Proposed Budget for Fort Bend County.

Moved by Commissioner Prestage, Seconded by Commissioner Patterson duly put and carried (4-1), it is ordered to approve 2000 budget and amendments as recommended by Jim Edwards, Budget Officer

Judge Adolphus	yes	Commissioner Meyers	no
Commissioner O'Shieles	yes	Commissioner Patterson	yes
Commissioner Prestage	yes		

16. COUNTY JUDGE:

A. Discuss and consider approving \$10,000 to be paid to Texana MHMR to assist in the payment of a consultant hired to recruit an Executive Director for Texana. (Fund: 010-045-4010)

Moved by Commissioner Patterson, Seconded by Commissioner Prestage, to approve \$10,000 to be paid to Texana MHMR to assist in hiring a consultant to recruit an executive director for Texana with the total cost of a consultant not to exceed \$15,000 (Fund 010-045-4010)

MOTION WITHDRAWN

Postpone until October 26

item #16 continued - County Judge:

B. Discuss and consider accepting Resolution to nominate candidates for the Central Appraisal District Board of Directors for the term 2000-2001.

Moved by Commissioner Prestage, Seconded by Commissioner Meyers, duly put and unanimously carried (5-0), it is ordered to adopt resolution to nominate the following candidates for the Central Appraisal District Board of Directors for the term 2000-2001

Judge Adolphus	ORIN COVILL
Commissioner O'Shieles	JAMES BAKER
Commissioner Prestage	KENNETH MARTINDALE
Commissioner Meyers	LEE DUGGAN III
Commissioner Patterson	DR GEORGE WOODLEY

Judge Adolphus	yes	Commissioner Meyers	yes
Commissioner O'Shieles	yes	Commissioner Patterson	yes
Commissioner Prestage	yes		

17. COUNTY ATTORNEY: Discuss and consider granting permission to Rosenberg Revitalization Association for use of parking lot at Fort Bend County-Rosenberg Annex for annual Christmas Magic event parking, Saturday, November 27, 1999.

Moved by Commissioner Meyers, Seconded by Commissioner O'Shieles, duly put and unanimously carried (5-0), it is ordered to grant permission to Rosenberg Revitalization Association for use of parking lot at Fort Bend County-Rosenberg Annex for annual Christmas Magic event parking, Saturday, November 27, 1999

Judge Adolphus	yes	Commissioner Meyers	yes
Commissioner O'Shieles	yes	Commissioner Patterson	yes
Commissioner Prestage	yes		

18. COMMUNITY DEVELOPMENT:

A. Discuss and approve Change Order No. 1 from Bass Construction for construction of the Pct. 1 Community Center Building. This is a reduction in the Contract Sum of \$2,007 and an increase in contract time of 137 days. Contract awarded to Bass by Commissioner Court 3/2/99, FBC Bid #99-025. (Fund: 840-101-8040)

Moved by Commissioner Patterson, Seconded by Commissioner O'Shieles, duly put and carried (4-1), it is ordered to approve Change Order No. 1 from Bass Construction for construction of the Pct 1 Community Center Building This is a reduction in the Contract Sum of \$2,007 and an increase in contract time of 137 days Contract awarded to Bass by Commissioner Court 3/2/99, FBC Bid #99-025 (Fund 840-101-8040)

Judge Adolphus	yes	Commissioner Meyers	no
Commissioner O'Shieles	yes	Commissioner Patterson	yes
Commissioner Prestage	yes		

item # 18 continued - Community Development:

- B. Discuss and approve Change Order No. 2 from Bass Construction for construction of the Pct. 1 Community Center Building. This is an increase in contract sum by \$40,349.40. (Fund: 840-101-8040)**

Moved by Commissioner O'Shieles, Seconded by Commissioner Prestage, duly put and carried (4-1), it is ordered to approve Change Order No 2 from Bass Construction for construction of the Pct 1 Community Center Building This is an increase in contract sum by \$40,349 40 (Fund 840-101-8040)

Judge Adolphus	yes	Commissioner Meyers	yes
Commissioner O'Shieles	yes	Commissioner Patterson	yes
Commissioner Prestage	yes		

- 19. ELECTIONS ADMINISTRATION: Discuss and consider adopting new boundary lines for precinct 3049 effective January 1, 2000.**

Moved by Commissioner Meyers, Seconded by Commissioner Prestage, duly put and unanimously carried (5-0), it is ordered to adopt Option C, new boundary lines for precinct 3049 effective January 1, 2000 as presented by Steve Raborn, Elections Administrator

Judge Adolphus	yes	Commissioner Meyers	yes
Commissioner O'Shieles	yes	Commissioner Patterson	yes
Commissioner Prestage	yes		

- 20. ENGINEERING:**

- A. Discuss and consider approving the agreement between the State of Texas, acting through the Texas Department of Transportation and Fort Bend County. FBC will initiate a preliminary engineering study for the proposed Fairgrounds Park & Ride and be partially reimbursed by Federal Funds**

- B. Discuss and consider adopting a resolution for the Fairgrounds Park & Ride committing Fort Bend County funds of \$62,500 for this project. Federal reimbursement is \$50,000. (Fund: TBD)**

Moved by Commissioner Meyers, Seconded by Commissioner Patterson, duly put and unanimously carried (5-0), it is ordered to approve items 20(a) and 20(b) for Engineering

Judge Adolphus	yes	Commissioner Meyers	yes
Commissioner O'Shieles	yes	Commissioner Patterson	yes
Commissioner Prestage	yes		

21. PURCHASING:

A. Authorize advertising for bids for the following:

- 1) Tires and tubes**
- 2) Photographic supplies**
- 3) Traffic signs/posts/supplies**
- 4) Oils and lubricants**
- 5) Weed, brush and insect control material**

Moved by Commissioner Meyers, Seconded by Commissioner O'Shieles, duly put and unanimously carried (5-0), it is ordered to authorize advertising for bids for items 21(a)(1) through 21(a)(5) for Purchasing as presented by Gilbert Jalomo, Purchasing Agent

Judge Adolphus	yes	Commissioner Meyers	yes
Commissioner O'Shieles	yes	Commissioner Patterson	yes
Commissioner Prestage	yes		

B. Authorize advertising for statements of qualification for engineering services for the Park & Ride at Fairgrounds.

Moved by Commissioner Patterson, Seconded by Commissioner Meyers, duly put and unanimously carried (5-0), it is ordered to authorize advertising for statements of qualification for engineering services for the Park & Ride at Fairgrounds as presented by Gilbert Jalomo, Purchasing Agent

Judge Adolphus	yes	Commissioner Meyers	yes
Commissioner O'Shieles	yes	Commissioner Patterson	yes
Commissioner Prestage	yes		

C. Consider taking action on Bid #99-079 purchasing of pre-engineered building.

Moved by Commissioner Meyers, Seconded by Commissioner Patterson, duly put and unanimously carried (5-0), it is ordered to award bid #99-079 to NCI Building Systems in the amount of \$48,173 37 for purchase of pre-engineered building for Drainage District as presented by Gilbert Jalomo, Purchasing Agent (Fund Drainage District 115-051-0510-1070)

Judge Adolphus	yes	Commissioner Meyers	yes
Commissioner O'Shieles	yes	Commissioner Patterson	yes
Commissioner Prestage	yes		

Item #21 continued - Purchasing:

D. Consider renewing the term contract for hauling and disposal of condensate/leachate – Bid #99-001.

Moved by Commissioner Meyers, Seconded by Commissioner Prestage, duly put and unanimously carried (5-0), it is ordered to renew the term contract with MagnaFlow for hauling and disposal of condensate/leachate – Bid #99-001 as presented by Gilbert Jalomo, Purchasing Agent

Judge Adolphus	yes	Commissioner Meyers	yes
Commissioner O’Shieles	yes	Commissioner Patterson	yes
Commissioner Prestage	yes		

E. Consider granting exemption to competitive bid process as authorized by 262.024 TLGC for a professional service – architectural service for Courthouse Rehabilitation Master Plan as required before submitting an Historical grant application. Not to exceed \$25,000. (Fund: TBD)

Moved by Commissioner Patterson, Seconded by Commissioner O’Shieles, duly put and unanimously carried (5-0), it is ordered to grant exemption to competitive bid process as authorized by 262 024 TLGC for a professional service – architectural service by Merriman Holt Architects for Courthouse Rehabilitation Master Plan as required before submitting an Historical grant application as presented by Gilbert Jalomo, Purchasing Agent and Tim Cumings, Grant Administrator Not to exceed \$25,000 (Fund TBD)

Contract and funding source to be approved at a later date

Judge Adolphus	yes	Commissioner Meyers	yes
Commissioner O’Shieles	yes	Commissioner Patterson	yes
Commissioner Prestage	yes		

22. Approve bills.

Moved by Commissioner Meyers, Seconded by Commissioner Patterson, duly put and unanimously carried (5-0), it is ordered to approve bills as presented by Kirk Kirkpatrick, Assistant County Auditor

Judge Adolphus	yes	Commissioner Meyers	yes
Commissioner O’Shieles	yes	Commissioner Patterson	yes
Commissioner Prestage	yes		

OCTOBER 12, 1999

Recess:

Recessed at 2 32 p m

Closed Session:

Convened at 2 42 p m

Adjourned at 2 56 p m

23. Meet in Closed Session to discuss the following matters:

- A. Personnel matters:** 1) **District Attorney**
 - 2) **Juvenile Probation**
- as authorized by TX Gov. Code, Sec. 551/074**

Reconvene:

Reconvened at 3 00 p m

24. Reconvene Open Session and consider taking action on the following Closed Session matters:

- A. Personnel matters:**
- 1) **District Attorney**

Moved by Commissioner Prestage, Seconded by Commissioner O'Shieles, duly put and carried (3-2), it is ordered to authorize reclassification of narcotics prosecutor at \$2,211 54 bi-weekly effective upon hiring new narcotics prosecutor on or about November 27 or December 11, 1999 for District Attorney

Judge Adolphus	yes	Commissioner Meyers	no
Commissioner O'Shieles	yes	Commissioner Patterson	no
Commissioner Prestage	yes		

Note This includes keeping the current narcotics prosecutor on payroll until he resigns, in order to train new narcotics prosecutor

- 2) **Juvenile Probation**
- as authorized by TX Gov. Code, Sec. 551/074**

No action

OCTOBER 12, 1999

25. Adjournment.

Moved by Commissioner Meyers, Seconded by Commissioner O'Shieles, duly put and unanimously carried (5-0), it is ordered to adjourn Commissioners Court at 3:03 p m on Tuesday, October 12, 1999.

Judge Adolphus	yes	Commissioner Meyers	yes
Commissioner O'Shieles	yes	Commissioner Patterson	yes
Commissioner Prestage	yes		

FORT BEND PARKWAY ROAD DISTRICT

BE IT REMEMBERED, That on the 12TH DAY of OCTOBER, 1999, Commissioners Court of Fort Bend County, Texas, sitting as the governing body of Fort Bend Parkway Road District met with the following present

JAMES C ADOLPHUS	COUNTY JUDGE
R L "BUD" O'SHIELES	COMMISSIONER PRECINCT 1
GRADY PRESTAGE	COMMISSIONER PRECINCT 2
ANDY MEYERS	COMMISSIONER PRECINCT 3
JAMES PATTERSON	COMMISSIONER PRECINCT 4
DIANNE WILSON	COUNTY CLERK

When the following were heard and the following orders passed

1. Call to Order.

Call to Order by Judge Adolphus at 2 10 p m

2. Hold public hearing to discuss the 2000 Budget for the Fort Bend Parkway Road District

No public comments

3. Discuss and consider accepting the 2000 Proposed Budget for the Fort Bend Parkway Road District.

Moved by Commissioner Prestage, Seconded by Commissioner O'Shieles, duly put and unanimously carried (5-0), it is ordered to accept the 2000 Proposed Budget for the Fort Bend Parkway Road District

Judge Adolphus	yes	Commissioner Meyers	yes
Commissioner O'Shieles	yes	Commissioner Patterson	yes
Commissioner Prestage	yes		

4. Adjournment.

The Fort Bend Parkway Road District adjourned at 2 12 p m on Tuesday, October 12, 1999

*Office of the County Judge
Fort Bend County, Texas*

Proclamation

- WHEREAS,* The family is the core of society; and
- WHEREAS,* the well-being of the family is dependent upon the development of the value system, and
- WHEREAS,* Texas Association for Family and Community Education with the National Association for Family and Community Education join voices in promoting NAFCE Week with the campaign, "Make a Date With Your Family", and
- WHEREAS,* the dates that individuals have with their families will foster communication, love and understanding within each family and strengthen their communities,

NOW, THEREFORE, I, JAMES C. ADOLPHUS, COUNTY JUDGE OF FORT BEND COUNTY, TEXAS, do hereby proclaim October 10 through October 16, 1999 as

National Family Community Education Week

in Fort Bend County and urge all citizens to join family and community education members and "Make a Date With Your Family"

*IN WITNESS WHEREOF, I have caused the Official
Seal of the Office of County Judge to be affixed this
12th day of October, 1999.*

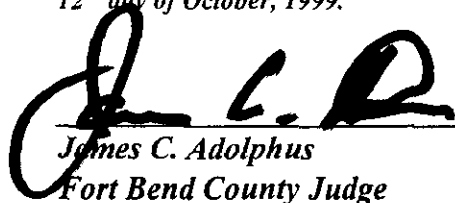
James C. Adolphus
Fort Bend County Judge



FF

*Office of the County Judge
Fort Bend County, Texas*

Proclamation

WHEREAS, an estimated 11,300 Texas women will be diagnosed with breast cancer in 1999, and about 2,800 women will die of the disease. Nationally, breast cancer is the most common form of cancer in women, and

WHEREAS, research shows that breast cancer mortality could be reduced by at least 30 percent if women followed recommended breast cancer screen guidelines, and

WHEREAS, all women have a chance of developing breast cancer. Women 50 or older are the most likely to develop breast cancer. African American women are the most likely to die of breast cancer than any other group of women. Getting a mammogram and breast exam only once is not enough. The American Cancer Society recommends that women get a mammogram and clinical breast examination every year beginning at age 40.

WHEREAS, a woman has the greatest chance of successful treatment if breast cancer is found at an early stage. Early detection practices are part of a good breast health routine. A good breast health routine includes a yearly mammogram, clinical breast examination and monthly breast self-examination.

WHEREAS, Medicare helps pay the costs of a yearly mammogram for women age 40 or older with Medicare Part B.

NOW, THEREFORE, I, JAMES C. ADOLPHUS, FORT BEND COUNTY JUDGE, in recognition of the important lifesaving early detection practices available for breast cancer, do hereby proclaim October 1999 as

Breast Cancer Awareness Month

and urge all Fort Bend County women to become aware that they are at risk and to discuss a screening program with their health care providers and urge all other Fort Bend County citizens to encourage a woman they love to do so.

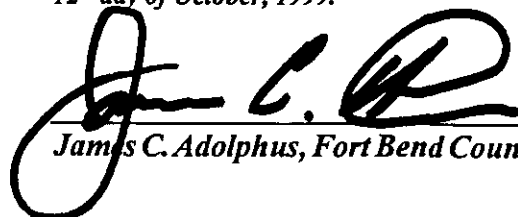

IN WITNESS WHEREOF, I have caused the Official Seal of the Office of County Judge to be affixed this 12th day of October, 1999.

James C. Adolphus, Fort Bend County Judge

IN THE MATTER OF TRANSFERRING OF BUDGET SURPLUS OF FORT BEND COUNTY FOR THE YEAR 1999

On this the 12 day of October, 1999, the Commissioners' Court, with the following members being present

- James Adolphus - County Judge
- R L O Shieles - Commissioner Precinct #1
- Grady Prestage - Commissioner Precinct #2
- Andy Meyers - Commissioner Precinct #3
- James Patterson - Commissioner Precinct #4

The following proceedings were had, to-wit,

THAT WHEREAS, theretofore, on October 13, 1998, the Court heard and approved the budget for the year 1999 for Fort Bend County, and

WHEREAS, on proper application, the Commissioners' Court has transferred an existing budget surplus to a budget of a similar kind and fund. The transfer does not increase the total of the budget.

The following transfers to said budget are hereby authorized

Department Name Constable, Pct. 2 Department # 024

TRANSFER TO:

LINE-ITEM NAME	NUMBER	AMOUNT
<u>CONF/TRAVEL</u>	<u>0701</u>	<u>\$1,188.00</u>

TOTAL TRANSFERRED TO \$ 1,188.00

TRANSFER FROM:

<u>CONTRACT DEP.</u>	<u>0702</u>	<u>1,188.00</u>

TOTAL TRANSFERRED FROM \$ 1,188.00

EXPLANATION Training Conference. (See Attached Letter)

Department Head *Robert Davis* Date 10-06-99

THE COUNTY OF FORT BEND ROUND DOLLARS ONLY

BY *J.A.R.*
James Adolphus, County Judge



CONSTABLE DEPARTMENT - PRECINCT TWO

Fort Bend County, Texas

RUBEN DAVIS
Constable

(281) 403-8010
Fax (281) 403-8025

October 6, 1999

TO: Jim Edwards, Budget Officer
Budget Office

FROM: Ruben Davis, Constable *RD*
Precinct Two

REF: Transfer of Funds Request to (0701) Travel/Training

I have been informed that Commissioners Court at Tuesday, October 5, 1999 meeting PASSED ON my request to transfer additional dollars into the department's (0701) Conference/Travel Request because there may have been some confusion about the present balance. Before submitting, my request for the transfer of funds, a review of the account balance showed a balance of \$ 161.47 dollars. (See the attached report date September 28, 1999)

I am resubmitting the attached request to transfer additional dollars into (0701) Conference/Travel Request account for my department to be place on the next Commissioners' Court Agenda. If you or any member of Commissioners' Court have any additional questions, please do not hesitate to contact me

Cc. James Adolphus, County Judge
R.L. "Bud" O'sheies, Commissioner, Pct 1
Grady Prestage, Commissioner, Pct 2
Andy Meyers, Commissioner, Pct 3
James Patterson, Commissioner, Pct 4

IN THE MATTER OF TRANSFERRING OF BUDGET SURPLUS OF FORT BEND COUNTY FOR THE YEAR 1999

On this the 12TH day of OCTOBER, 1999, the Commissioners' Court with the following members being present

- James Adolphus - County Judge
- R L O Shieles - Commissioner Precinct #1
- Grady Prestage - Commissioner Precinct #2
- Andy Meyers - Commissioner Precinct #3
- James Patterson - Commissioner Precinct #4

The following proceedings were had, to-writ,

THAT WHEREAS, theretofore, on October 13, 1998, the Court heard and approved the budget for the year 1999 for Fort Bend County, and

WHEREAS, on proper application, the Commissioners' Court has transferred an existing budget surplus to a budget of a similar kind and fund. The transfer does not increase the total of the budget.

The following transfers to said budget are hereby authorized

Department Name CONSTABLE PCT. 3 Department # 25

TRANSFER TO:

LINE-ITEM NAME	NUMBER	AMOUNT
PROPERTY AND EQUIPMENT	1010	1400.00
TOTAL TRANSFERRED TO \$		1400.00

TRANSFER FROM:

UNIFORMS	4011	1400.00
TOTAL TRANSFERRED FROM \$		1400.00

EXPLANATION THIS WILL ENABLE OUR DEPARTMENT TO HAVE AVAILABLE FUNDS TO PURCHASE DECALS FOR OUR PATROL VEHICLES.

Department Head Rob Cook Date 10-1-99

THE COUNTY OF FORT BEND ROUND DOLLARS ONLY

BY [Signature]
James Adolphus, County Judge

5B
/



CONSTABLE PRECINCT 3
Fort Bend County, Texas

ROB COOK
Constable

(281) 491-7226
Fax (281) 491-0678

October 1, 1999

Judge James C Adolphus
309 S 4th Street, Ste 719
Richmond, Texas 77469

Re Agenda Item

Dear Judge Adolphus

This letter is being submitted to your office to request that the following item be included on the Commissioner's Court Agenda for Tuesday, October 12, 1999

I am requesting a budget transfer in the amount of \$1,400 00 from Uniforms (4011) to Property and Equipment (1010) This will enable our department to have available funds to purchase Decals for our patrols vehicles

If you should have any questions or need additional information, please don't hesitate to give me a call

Thank You for your cooperation in this matter

Sincerely,

Rob Cook
Constable Precinct #3

RC/js

- xc Comm R L O'Shieles
- Comm Grady Prestage
- Comm Andy Meyers
- Comm James Patterson
- County Clerk, Diane Wilson
- County Auditor, Robert Grayless
- Budget Officer, Jim Edwards

50

IN THE MATTER OF TRANSFERRING OF BUDGET SURPLUS OF FORT BEND COUNTY
FOR THE YEAR 1999

On this the 12TH day of OCTOBER, 1999, the Commissioners Court, with the following members being present

James Adolphus	-	County Judge
R L O'Shieles	-	Commissioner Precinct #1
Grady Prestage	-	Commissioner Precinct #2
Andy Meyers	-	Commissioner Precinct #3
James Patterson	-	Commissioner Precinct #4

The following proceedings were had, to-wit,

THAT WHEREAS, theretofore, on October 13, 1998, the Court heard and approved the budget for the year 1999 for Fort Bend County; and

WHEREAS, on proper application, the Commissioners' Court has transferred an existing budget surplus to a budget of a similar kind and fund. The transfer does not increase the total of the budget

The following transfers to said budget are hereby authorized

Department Name CONSTABLE PCT 3 Department # 25

TRANSFER TO

LINE-ITEM NAME	NUMBER	AMOUNT
PROPERTY & EQUIPMENT	4010	400.00
<u>FEES AND SERVICES</u>		
TOTAL TRANSFERRED TO \$		400.00

TRANSFER FROM

<u>UNIFORMS</u>	4011	400.00
TOTAL TRANSFERRED FROM \$		400.00

EXPLANATION TRANSFER MONEY TO COVER REMAINING BALANCES FOR ENTERING AND CLEARING WARRANTS FROM JIMS FOR DECEMBER 31, 1999.

Department Head Rob Coal Date 9-29-99

THE COUNTY OF FORT BEND ROUND DOLLARS ONLY

BY J.A.R.
James Adolphus, County Judge

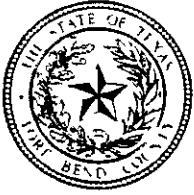

CONSTABLE PRECINCT 3
Fort Bend County, Texas

15/2

ROB COOK
Constable

(281) 491-7226
Fax (281) 491-0678

September 29, 1999

Judge James C Adolphus
309 S 4th Street, Ste' 719
Richmond, Texas 77469

Re Agenda Item

Dear Judge Adolphus

This letter is being submitted to your office to request that the following item be included on the Commissioner's Court Agenda for Tuesday, October 12, 1999

I am requesting a modification on purchase order number PC025-00000532 in the original amount of \$400.00 to be increase by another \$400.00 This will enable our department to have available funds to cover the remaining balances for entering & clearing warrants for December 31, 1999 Please transfer \$400.00 from Uniforms (4011) to Property and Equipment (4010)

If you should have any questions or need any additional information, please don't hesitate to give me a call

Thank You for your cooperation in this matter

Sincerely,

Rob Cook
Constable Precinct #3

RC/js

xc Comm R L O'Shieles
Comm Grady Prestage
Comm Andy Meyers
Comm James Patterson
County Clerk, Diane Wilson
County Auditor, Robert Grayless
Budge Officer, Jim Edwards

FORT BEND COUNTY, TEXAS PURCHASE ORDER

AS PER ORIGINAL

P O NUMBER **PC 0250000532**

SPECIAL INSTRUCTIONS

PAGE # **01**

FILE COPY

DATE: **01-15-1999**

DELIVER BY: **01-15-1999**

BUYER **15 CHRISTINA TORRES** CONFIRMING **NO** FOB **D**
VENDOR **746019451 - B** SHIP TO
HARRIS COUNTY - J I M S
406 CAROLINE, 2ND FLOOR
ANNEX 18 BILL TO
HOUSTON TX 77002

CONSTABLE PCT-3
12803 PARK ONE DR.
SUGAR LAND TX, 77487
CONSTABLE PCT 3
12803 PARK ONE DR.
SUGAR LAND TX 77478

DESCRIPTION	QUANTITY	UNIT COST	EXTENDED CO
001 522	1.000 EA	400.00000	400.00
010 025 0250 1600 4010 01			
BLANKET P.O. FOR ENTERING & CLEARING WARRANTS - 1999			

PAGE TOTAL **400.00**
GRAND TOTAL **400.00**

BY MY SIGNATURE I ATTEST THE ITEMS ON THIS ORDER HAVE BEEN RECEIVED AND THAT ALL ITEMS MEET SPECIFICATIONS

SIGNATURE OF PURCHASING AGENT

AUTHORIZED SIGNATURE/DATE

IN THE MATTER OF TRANSFERRING OF BUDGET SURPLUS OF FORT BEND COUNTY FOR THE YEAR 1999

On this the _____ day of _____, 1999, the Commissioners' Court, with the following members being present

- James Adolphus - County Judge
- R L O'Shieles - Commissioner Precinct #1
- Grady Prestage - Commissioner Precinct #2
- Andy Meyers - Commissioner Precinct #3
- James Patterson - Commissioner Precinct #4

The following proceedings were had, to-writ,

THAT WHEREAS, theretofore, on October 13, 1998, the Court heard and approved the budget for the year 1999 for Fort Bend County, and

WHEREAS, on proper application, the Commissioners' Court has transferred an existing budget surplus to a budget of a similar kind and fund The transfer does not increase the total of the budget

The following transfers to said budget are hereby authorized

Department Name Veteran Services Department # 35

TRANSFER TO:

LINE-ITEM NAME	NUMBER	AMOUNT
rentals	3020	25.00
TOTAL TRANSFERRED TO		\$ 25.00

TRANSFER FROM:

automobiles	6025	25.00
TOTAL TRANSFERRED FROM		\$ 25.00

EXPLANATION did not know how much I was going to use in a year, because I did not have it a full year before budget year 1997.

Department Head *Patrick Conwell* Date 10/5/99

THE COUNTY OF FORT BEND
BY *J.A.R.*
James Adolphus, County Judge

ROUND DOLLARS ONLY
Oban
af

IN THE MATTER OF TRANSFERRING OF BUDGET SURPLUS OF FORT BEND COUNTY FOR THE YEAR 1999

On this the 12th day of October 1999 the Commissioners' Court, with the following members being present:

- James Adolphus - County Judge
- R L O'Shieles - Commissioner Precinct #1
- Grady Prestage - Commissioner Precinct #2
- Andy Meyers - Commissioner Precinct #3
- James Patterson - Commissioner Precinct #4

The following proceedings were had, to-wrt,

THAT WHEREAS, theretofore, on October 13, 1998 the Court heard and approved the budget for the year 1999 for Fort Bend County, and

WHEREAS, on proper application, the Commissioners' Court has transferred an existing budget surplus to a budget of a similar kind and fund. The transfer does not increase the total of the budget.

The following transfers to said budget are hereby authorized:

Department Name M.I.S. Department # 036

TRANSFER TO:

LINE-ITEM NAME	NUMBER	AMOUNT
<u>Conferences & Training</u>	<u>0701</u>	<u>\$ 5,000.00</u>
TOTAL TRANSFERRED TO		<u>\$ 5,000.00</u>

TRANSFER FROM

<u>Fees & Services</u>	<u>4010</u>	<u>\$ 5,000.00</u>
TOTAL TRANSFERRED FROM		<u>\$ 5,000.00</u>

EXPLANATION

On August 31st, Commissioner's Court approved the transfer of \$5,000.00 from Administrative Services - Property and Equipment to MIS Fees and Services. The transfer was to cover expenses of Microsoft Office 97 training for County employees. However, the expenditure is actually incurred in MIS Conferences and Training. Therefore, I respectfully request to have the \$5,000.00 transferred from MIS Fees and Services in to MIS Conferences and Training.

Department Head Connie Heinicke Date 10-5-99

THE COUNTY OF FORT BEND

ROUND DOLLARS ONLY

BY

J.A.R.

James Adolphus County Judge

**FORT BEND COUNTY
COMMISSIONERS COURT AGENDA REQUEST FORM
RETURN TO: AGENDA COORD.-COUNTY JUDGE'S OFFICE**

DATE SUBMITTED:	10/06/99	SUBMITTED BY:	Connie Heinecke	AGENDA
COURT AGENDA DATE:	10/12/99	DEPARTMENT:	M.I.S. (036)	ITEM
		PHONE NO.:	281-341-4570	#

SUMMARY OF ITEM:**MANAGEMENT INFORMATION SERVICES:**

On August 31st, Commissioner's Court approved the transfer of \$5,000.00 from Administrative Services Property and Equipment to MIS Fees and Services (4010). The transfer was to cover expenses of Microsoft Office 97 training for County employees. However, the expenditure is actually incurred in MIS Conferences and Training (0701). Therefore, I respectfully request to have the \$5,000.00 transferred from MIS Fees and Services (4010), in to MIS Conferences and Training (0701).

RENEWAL CONTRACT/AGREEMENT: Yes () No (X)

LIST SUPPORTING DOCUMENTS ATTACHED:

See Line Item Transfer Sheet attached

(Back-up documentation must be attached for consideration)

FINANCIAL SUMMARY:

BUDGETED ITEM.	ANNUALIZED DOLLARS.	COMMENTS.
Yes () No () N/A (X)	One Time ()	
Funding Source:	Recurring ()	
Fund: 010 Agcy: 036 Object: 4010	N/A ()	

Original Form Submitted with back up to County Judge's Office: Yes (X)

CC with back up:

(X) Auditor	(281-341-3774)	(X) Comm. Pct. 1	(281-342-0587)
(X) Budget Officer	(281-344-3954)	(X) Comm. Pct. 2	(281-403-8009)
(X) County Attorney	(281-341-4557)	(X) Comm. Pct. 3	(281-242-9060)
(X) Purchasing Agent	(281-341-8642)	(X) Comm. Pct. 4	(281-980-9077)

Instructions for submitting an Agenda Request:

1. Completely fill out agenda form, incomplete forms will not be processed.
2. Fax or inter-office copies of agenda form with all back up information by Wednesday at 2:00 p.m. to the departments listed above.
3. All original back-up must be received in the County Judges Office by 2:00 p.m. on Wednesday.

RECOMMENDATION / ACTION REQUESTED:

Request Commissioner's Court approval

5F

IN THE MATTER OF TRANSFERRING OF BUDGET SURPLUS OF FORT BEND COUNTY FOR THE YEAR 1999

On this the 12TH day of OCTOBER, 1999, the Commissioners' Court, with the following members being present

- James Adolphus - County Judge
- R L O'Shieles - Commissioner Precinct #1
- Grady Prestage - Commissioner Precinct #2
- Andy Meyers - Commissioner Precinct #3
- James Patterson - Commissioner Precinct #4

The following proceedings were had, to-wit,

THAT WHEREAS, theretofore, on October 13, 1998, the Court heard and approved the budget for the year 1999 for Fort Bend County; and

WHEREAS, on proper application, the Commissioners' Court has transferred an existing budget surplus to a budget of a similar kind and fund The transfer does not increase the total of the budget

The following transfers to said budget are hereby authorized

Department Name ENGINEERING Department # 043

TRANSFER TO:

LINE-ITEM NAME	NUMBER	AMOUNT
HOUSEHOLD HAZARDOUS WASTE	911-043-0435-1400	\$4,326.14
TOTAL TRANSFERRED TO \$		4,326.14

TRANSFER FROM:

GENERAL FUND CONTINGENCY	010-045-4040	\$4,326.14
TOTAL TRANSFERRED FROM \$		\$4,326.14

EXPLANATION MSE (THE DISPOSAL COMPANY), IS STILL DUE PAYMENT ON THE APRIL 17, 1999 HOUSEHOLD HAZARDOUS/AGRICULTURAL WASTE COLLECTION EVENT.

Department Head [Signature] Date 10/06/99

THE COUNTY OF FORT BEND ROUND DOLLARS ONLY

BY. [Signature] James Adolphus, County Judge

IN THE MATTER OF TRANSFERRING OF BUDGET SURPLUS OF FORT BEND COUNTY
FOR THE YEAR 1999

5H

On this the 2 day of October, 1999, the Commissioners' Court, with the following members being present

- James Adolphus - County Judge
- R L O'Shieles - Commissioner Precinct #1
- Grady Prestage - Commissioner Precinct #2
- Andy Meyers - Commissioner Precinct #3
- James Patterson - Commissioner Precinct #4

The following proceedings were had, to-wit,

THAT WHEREAS, theretofore, on October 13, 1998, the Court heard and approved the budget for the year 1999 for Fort Bend County, and

WHEREAS, on proper application, the Commissioners' Court has transferred an existing budget surplus to a budget of a similar kind and fund. The transfer does not increase the total of the budget.

The following transfers to said budget are hereby authorized

Department Name Non Departmental Department # 045

TRANSFER TO.

LINE-ITEM NAME	NUMBER	AMOUNT
<u>Fees/Services</u>	<u>4010</u>	<u>\$100,000</u>
TOTAL TRANSFERRED TO \$		<u>\$100,000</u>

TRANSFER FROM:

<u>Contingency</u>		<u>\$100,000</u>
TOTAL TRANSFERRED FROM \$		<u>\$100,000</u>

EXPLANATION Pay contract commitment through the end of the year, including Allison, Bass & Assoc. for redistricting approved 4/13/99

Department Head J.C.R. Date 10/5/1999

THE COUNTY OF FORT BEND ROUND DOLLARS ONLY

BY J.C.R.
James Adolphus, County Judge

[Handwritten initials]

APRIL 13, 1999

17. TAX ASSESSOR/COLLECTOR: Consider approving over \$500.00 refunds for the following:

Countrywide Home Loans	\$2890.77 (Erroneous Payment)
Countrywide Home Loans	\$3004.61 (Erroneous Payment)

Moved by Commissioner Prestage, Seconded by Commissioner O'Shieles, duly put and unanimously carried (5-0), it is ordered to approve over \$500 00 refunds for the following

Countrywide Home Loans	\$2890 77 (Erroneous Payment)
Countrywide Home Loans	\$3004 61 (Erroneous Payment)

Judge Adolphus	yes	Commissioner Meyers	yes
Commissioner O'Shieles	yes	Commissioner Patterson	yes
Commissioner Prestage	yes		

18. TREASURER: Consider approving bills in the amount of \$52,200.00 for Fort Bend Flood Control Water Supply Corporation. (Fund: 264 006 4010)

Moved by Commissioner Prestage, Seconded by Commissioner O'Shieles, duly put and unanimously carried (5-0), it is ordered to approve bills in the amount of \$52,200 00 for Fort Bend Flood Control Water Supply Corporation (Fund 264 006 4010)

Judge Adolphus	yes	Commissioner Meyers	yes
Commissioner O'Shieles	yes	Commissioner Patterson	yes
Commissioner Prestage	yes		

19. COUNTY ATTORNEY: Discuss and consider taking action on entering into a contract regarding redistricting presentation given by attorney Jim Allison.

Moved by Commissioner Prestage, Seconded by Commissioner Meyers, duly put and unanimously carried (5-0), it is ordered to enter into a contract between Fort Bend County and Allison Bass & Associates pending County Attorney review regarding redistricting not to exceed \$90,000 as presented by Jim Allison

Judge Adolphus	yes	Commissioner Meyers	yes
Commissioner O'Shieles	yes	Commissioner Patterson	yes
Commissioner Prestage	yes		

IN THE MATTER OF TRANSFERRING OF BUDGET SURPLUS OF FORT BEND COUNTY
FOR THE YEAR 1999

51

On this the _____ day of _____, 1999, the Commissioners' Court, with the following members being present

- James Adolphus - County Judge
- R L O'Shieles - Commissioner Precinct #1
- Grady Prestage - Commissioner Precinct #2
- Andy Meyers - Commissioner Precinct #3
- James Patterson - Commissioner Precinct #4

The following proceedings were had, to-writ,

THAT WHEREAS, theretofore, on October 13, 1998, the Court heard and approved the budget for the year 1999 for Fort Bend County, and

WHEREAS, on proper application, the Commissioners' Court has transferred an existing budget surplus to a budget of a similar kind and fund. The transfer does not increase the total of the budget

The following transfers to said budget are hereby authorized

Department Name Drainage District Department # 051

TRANSFER TO:

LINE-ITEM NAME	NUMBER	AMOUNT
<u>Permanent Improvements</u>	<u>115-051-0510-1070</u>	<u>\$2,000.00</u>
_____	_____	_____
_____	_____	_____
_____	_____	_____
TOTAL TRANSFERRED TO \$		<u>2,000.00</u>

TRANSFER FROM:

<u>Repairs - Buildings</u>	<u>115-051-0510-7012</u>	<u>\$2,000.00</u>
_____	_____	_____
_____	_____	_____
_____	_____	_____
TOTAL TRANSFERRED FROM \$		<u>2,000.00</u>

EXPLANATION To cover cost of materials for metallic storage building
at 1022 Blume Rd., Rosenberg, Tx

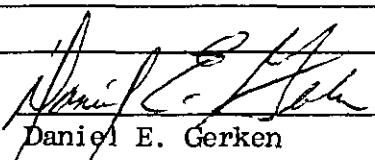
Department Head  Date 10/5/99
Daniel E. Gerken

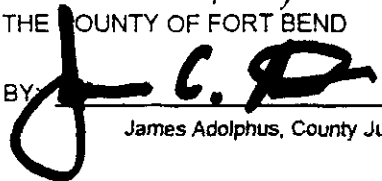
THE COUNTY OF FORT BEND ROUND DOLLARS ONLY
BY: 
James Adolphus, County Judge



IN THE MATTER OF TRANSFERRING OF BUDGET SURPLUS OF FORT BEND COUNTY
FOR THE YEAR 1999

5J

On this the _____ day of _____ 1999 the Commissioners' Court, with the following members being present

- James Adolphus - County Judge
- R L O'Shieles - Commissioner Precinct #1
- Grady Prestage - Commissioner Precinct #2
- Andy Meyers - Commissioner Precinct #3
- James Patterson - Commissioner Precinct #4

The following proceedings were had, to-wit,

THAT WHEREAS, theretofore, on October 13, 1998, the Court heard and approved the budget for the year 1999 for Fort Bend County, and

WHEREAS, on proper application, the Commissioners' Court has transferred an existing budget surplus to a budget of a similar kind and fund. The transfer does not increase the total of the budget

The following transfers to said budget are hereby authorized

Department Name COUNTY COURT AT LAW NO.3 Department # 56

TRANSFER TO

LINE-ITEM NAME	NUMBER	AMOUNT
<u>FEES AND SERVICES</u>	<u>4010</u>	<u>\$ 20,000.00</u>
_____	_____	_____
_____	_____	_____
_____	_____	_____

TOTAL TRANSFERRED TO \$ 20,000.00

TRANSFER FROM:

<u>CONTINGENCY</u>	<u>045</u>	<u>\$20,000.00</u>
_____	_____	_____
_____	_____	_____
_____	_____	_____

TOTAL TRANSFERRED FROM \$ 20,000.00

EXPLANATION *Original budgeted amount not sufficient due to continued CPS cases juvenile appointments, Child Custody Case, and Criminal Appointments.*

Department Head *[Signature]* Date 10-5-99

THE COUNTY OF FORT BEND ROUND DOLLARS ONLY

BY *[Signature]*
James Adolphus, County Judge

[Signature]

IN THE MATTER OF TRANSFERRING OF BUDGET SURPLUS TO FORT BEND COUNTY
FOR THE YEAR 1999

5K

On this the 12 day of OCTOBER, 1999, the Commissioners' Court, with the following members being present

- James Adolphus - County Judge
- R L O'Shieles - Commissioner Precinct #1
- Grady Prestage - Commissioner Precinct #2
- Andy Meyers - Commissioner Precinct #3
- James Patterson - Commissioner Precinct #4

The following proceedings were had, to-wit,

THAT WHEREAS, theretofore, on October 13, 1998, the Court heard and approved the budget for the year 1999 for Fort Bend County, and

WHEREAS, on proper application, the Commissioners' Court has transferred an existing budget surplus to a budget of a similar kind and fund. The transfer does not increase the total of the budget

The following transfers to said budget are hereby authorized

Department Name COMMISSIONER Prec. 2 Department # 072

TRANSFER TO.

LINE-ITEM NAME	NUMBER	AMOUNT
<u>CONFERENCES/TRAVELS</u>	<u>010-072-1010</u>	<u>1,500.00</u>

TOTAL TRANSFERRED TO \$ 1,500.00

TRANSFER FROM:

<u>FEES & SERVICES</u>	<u>010-072-4010</u>	<u>1,500.00</u>

TOTAL TRANSFERRED FROM \$ 1,500.00

EXPLANATION To pay pending bills and travels for
Balance of the year.

Department Head Carish W. [Signature] Date 10/5/99

THE COUNTY OF FORT BEND ROUND DOLLARS ONLY

BY [Signature]
James Adolphus, County Judge

[Signature]

IN THE MATTER OF TRANSFERRING OF BUDGET SURPLUS OF FORT BEND COUNTY
FOR THE YEAR 1999

5L

On this the 12TH day of OCTOBER 1999, the Commissioners' Court, with the following members being present

- James Adolphus - County Judge
- R L O Shieles - Commissioner Precinct #1
- Grady Prestage - Commissioner Precinct #2
- Andy Meyers - Commissioner Precinct #3
- James Patterson - Commissioner Precinct #4

The following proceedings were had, to-writ,

THAT WHEREAS, theretofore, on October 13, 1998, the Court heard and approved the budget for the year 1999 for Fort Bend County, and

WHEREAS, on proper application, the Commissioners' Court has transferred an existing budget surplus to a budget of a similar kind and fund. The transfer does not increase the total of the budget.

The following transfers to said budget are hereby authorized

Department Name ROAD & BRIDGE Department # 075

TRANSFER TO:

LINE-ITEM NAME	NUMBER	AMOUNT
<u>OVERTIME</u>	<u>105-075-0750-0202</u>	<u>\$50,000</u>
<u>ROAD SIGNS</u>	<u>105--75-0750-7004</u>	<u>15,000</u>
	TOTAL TRANSFERRED TO \$	<u>65,000</u>

TRANSFER FROM:

<u>SALARIES</u>	<u>105-075-0750-0200</u>	<u>\$50,000</u>
<u>FEES & SERVICES</u>	<u>105-075-0750-4010</u>	<u>15,000</u>
	TOTAL TRANSFERRED FROM \$	<u>65,000</u>

EXPLANATION TRANSFER INTO OVERTIME DUE TO EXTENDED HOURS NECESSARY TO COMPLETE ROAD PROJECTS. TRANSFER INTO ROAD SIGNS DUE TO INCREASE IN VANDALISM OF SIGNS THROUGH OUT THE COUNTY.

Department Head C.W. Henry Date 9/30/99

THE COUNTY OF FORT BEND ROUND DOLLARS ONLY

BY J.C.A.
James Adolphus, County Judge

Handwritten initials/signature

#6

FORT BEND COUNTY TRAVEL AUTHORIZATION

TO: COMMISSIONERS COURT

I hereby request permission for the following person(s) to make an official trip outside of Fort Bend County:

Molly Krukewitt
Sandy VanLandingham

DATE OF DEPARTURE 11-9-99

DATE OF RETURN 11-14-99

DESTINATION Denver, Colorado

PURPOSE OF TRIP Healthy Communities-Healthy Youth Conference
on working with youth at risk

MODE OF TRANSPORTATION air

FUNDING SOURCE: #0701 Conferences to be reimbursed by grant

DEPARTMENT HEAD APPROVAL: Roman S. Bohachevsky, Library
Name & Department

DATE: 10/6/99

Roman S Bohachevsky
Signature

APPROVED COMMISSIONERS COURT: Presiding Official [Signature]

Date 10-12-99

(Emergency Approval. _____ Date _____)



FORT BEND COUNTY LIBRARIES

ROMAN S BOHACHEVSKY
County Librarian

MEMORANDUM

TO: Judge James C Adolphus
Commissioner R.L Bud O'Shieles
Commissioner Grady Prestage
Commissioner Andy Meyers
Commissioner James Patterson

DATE: 10/6/99

FROM: Roman S. Bohachevsky

SUBJECT: Out of state travel

Attached is a travel request for two of my staff, Molly Krukewitt and Sandy Van Landingham. They would like to attend a conference in Denver, CO that deals directly with the issues addressed by our Reader's Digest Fund grant. This is a Reader's Digest recommended conference, and we will be reimbursed by it.

Roman S Bohachevsky

RSB/dmf

Attachment

**FORT BEND COUNTY LIBRARIES
REQUEST FOR TRAVEL**

**SUBMITTED BY
DATE**

Molly Krukewitt
September 21, 1999

PERSON(S)

Molly Krukewitt
Sandy VanLandingham

DATE OF DEPARTURE

Thursday, November 9, 1999

DATE OF RETURN

Sunday, November 14, 1999

DESTINATION

Denver, Colorado-Adam's Mark Hotel

PURPOSE OF TRIP

Healthy Communities-Healthy Youth Conference-To better understand the developmental assets of youth, how to develop youth advisory boards, and to value youth in the library and in our community This is a basic concept of the DeWitt Wallace-Reader's Digest Fund philosophy which we are expected to follow in our grant during the next three years

MODE OF TRANSPORTATION

Airfare roundtrip for two people @ \$329 50 = **\$659**

FUNDING SOURCE

The DeWitt Wallace-Reader's Digest grant is scheduled to pay for this trip The money is expected to come to Fort Bend County in November, 1999

FORT BEND COUNTY
COMMISSIONERS COURT AGENDA REQUEST FORM
 RETURN TO: AGENDA COORD.-COUNTY JUDGE'S OFFICE

DATE SUBMITTED: 10/4/99
 COMMISSIONERS COURT AGENDA FOR: 10/12/99

DEPT. SUBMITTED BY: County Attorney for Commissioner Pct 3
 DEPT. PHONE NO. 281-341-4556 #7

SUMMARY OF ITEM:

Consider approving request for annexation of land into North Mission Glen Municipal Utility District.

RENEWAL CONTRACT/AGREEMENT: Yes () No (X)

LIST SUPPORTING DOCUMENTS ATTACHED: yes
 (Back-up documentation must be attached for consideration)

FINANCIAL SUMMARY:

BUDGETED ITEM	ANNUALIZED DOLLARS:	COMMENTS:
Yes() No() N/A()	One Time ()	
Funding Source:	Recurring ()	
Fund _____ Agcy. _____ Object _____	N/A ()	

Original form submitted with back up to County Judge's Office: Yes: (x)

CC with back up:

Auditor (281-341-3774)	Comm. Pct. 1 (281-344-0587)
Budget Officer (281-344-3954)	Comm. Pct. 2 (281-403-8009)
County Attorney (281-341-4557)	Comm. Pct. 3 (281-242-9060)
Purchasing Agent (281-341-8642)	Comm. Pct. 4 (281-980-9077) yes

Instructions for submitting an Agenda Request:

- 1 Completely fill out agenda form, incomplete forms will not be processed
- 2 Fax or inter-office copies of agenda form with all back-up information by Wednesday at 2:00 p.m. to the departments listed above.
- 3 All original back-up must be received in the County Judge's Office by 2 00 p m on Wednesday

10-20-99 All original Petitions mailed back to Linda Rowlett at Coats, Rose, Yale, Reymann, + Lee.

COATS, ROSE, YALE, RYMAN & LEE

A PROFESSIONAL CORPORATION

ATTORNEYS AT LAW

800 FIRST CITY TOWER

1001 FANNIN

HOUSTON, TEXAS 77002-6707

TELEPHONE (713) 651-0111

TELECOPIER (713) 651-0220

September 28, 1999

Ms Mandi Bronsell
Agenda Coordinator
Fort Bend County Judge
309 South Fourth Street, Suite 719
Richmond, Texas 77469

Re North Mission Glen Municipal Utility District

Dear Ms Bronsell

We have another proposed annexation of property into North Mission Glen Municipal Utility District that includes Fort Bend County on the tax assessor/collector certification for ownership of certain road rights-of-way. Therefore, we need the County's signature on the annexation petitions. Please find enclosed ~~four originals~~ of a petition to the Board of Directors of the District and ~~nine originals~~ of a petition to the City of Houston regarding the proposed annexation of 103.132 acres of land. Please have ~~all originals signed~~ where indicated and return them to me for further processing.

As soon as the instruments are fully executed, I will return an original of each to you for the County's files.

If you have any questions, please feel free to call me at 713-653-7312. Thank you in advance for your assistance in this matter.

Very truly yours,



Linda L. Rowlett, Ph.D.
Legal Assistant

Enclosures

LLR\170517\1\TR\FORTBENDCOUNTYJUDGE401

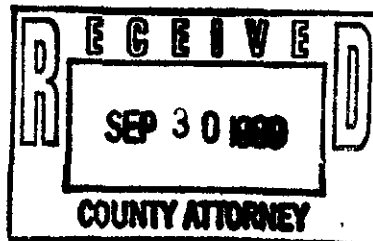

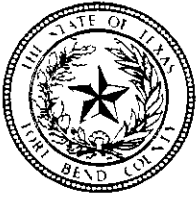

TAX ASSESSOR/COLLECTOR
FORT BEND COUNTY, TEXAS

MARSHA P. GAINES

June 1, 1999

(281) 341-3710
Fax (281) 341-9267

Certificate #391

State of Texas

County of Fort Bend

I, the undersigned, hereby certify that I have examined the tax roll of Fort Bend County, Texas, and find that the property described in Exhibit "A" of the petition of land proposed to be annexed into North Mission Glen Municipal Utility District containing 103.1320 acres, attached hereto, is assessed on the 1998 tax rolls of Fort Bend County in the name of.

0402-00-000-1700-907 WORLDSCO CO LTD
Abst 0402 JNO LEVERTON, ACRES 93.685
Land 479,510 Impr 700 Net 480,210 Value

0402-00-000-1703-907 FT BEND COUNTY
Abst 0402 JNO LEVERTON, ACRES 3.038,
ADDICKS CLODINE ROAD ROW (AREA 2), EXEMPT
Land 300 Net 0 Value

0402-00-000-1704-907 FT BEND COUNTY
Abst 0402 JNO LEVERTON, ACRES 1.576,
ADDICKS CLODINE ROAD ROW, EXEMPT
Land 300 Net 0 Value

0402-00-000-1705-907 FT BEND COUNTY
Abst 0402 JNO LEVERTON, ACRES 4.833,
BISSONNET ST ROW, EXEMPT
Land 300 Net 0 Value

Witness my hand the official seal this 1st day of June 1999.

Marsha P. Gaines
Tax Assessor / Collector

PETITION FOR ADDITION OF CERTAIN LANDS TO
NORTH MISSION GLEN MUNICIPAL UTILITY DISTRICT

TO THE BOARD OF DIRECTORS OF NORTH MISSION GLEN MUNICIPAL UTILITY
DISTRICT OF FORT BEND COUNTY, TEXAS:

We, the undersigned (herein the "Petitioners") owners of the land described by metes and bounds in Exhibit A (attached hereto and incorporated herein for all purposes) and acting pursuant to the provisions of Chapters 49 and 54, Texas Water Code, particularly Section 49 301 of that Code, together with all amendments and additions thereto, respectfully petition this Honorable Board that the land described by metes and bounds in Exhibit A be added to become a part of the established North Mission Glen Municipal Utility District of Fort Bend County, Texas (the "District"), and in support of this petition would show as follows:

I

The undersigned are the owners of title to land within the territory described in Exhibit A and are the only owners of such land, as shown by the tax rolls of Fort Bend County, Texas.

II

The addition of said land to North Mission Glen Municipal Utility District of Fort Bend County, Texas, is feasible and practical and would be of benefit both to the area to be added and to the District.

III.

This Petition shall constitute an election on the part of Petitioners, their successors, and assigns, for the aforesaid land and any improvements which are now or may hereafter be constructed thereon to become liable for all present and future debts of the District in the same manner and to the same extent as other lands and improvements in the District are liable for the District's debts

IV

Without limiting the generality of Paragraph III above, Petitioners are aware that the District has heretofore issued a total of \$12,470,000 of its Unlimited Tax Bonds and \$5,750,000 of its Unlimited Tax Refunding Bonds. Petitioners hereby agree that the land and all improvements thereon, presently existing or to be constructed, shall assume its share of all bonds or other obligations of the District and must be taxed equally with all other property within the District. Petitioners acknowledge, consent to, and affirmatively request the assumption by the area to be

annexed of a pro rata share of all obligations of the District and of the taxes to be levied or hereafter to be levied by the District.

V.

Petitioners, their successors, and assigns, hereby agree that the land and any improvements existing or to be constructed thereon shall be liable for its pro rata share of all voted but unissued bonds of the District which were authorized at various elections held within the District and which may hereafter be issued and sold by the District. This Petition constitutes authorization by Petitioners, their successors, and assigns, for the Board of Directors of the District to issue and sell all of the remaining unissued bonds for the purposes and upon the terms and conditions such bonds were voted, in one or more issues or series, at a future date or dates, when in the Board's judgment such amounts are required for the authorized purposes.

VI.

This Petition shall further be considered the consent and authorization of Petitioners, their successors, and assigns, for all the taxable land described in Exhibit A and all improvements now existing or to be constructed thereon to be taxed uniformly and equally on an ad valorem basis with all other taxable property within the District for: (1) the payment of principal and interest on the District's outstanding bonds; (2) the payment of principal and interest on the District's voted but unissued bonds; and (3) all other purposes for which the District may lawfully levy taxes, including taxes levied for maintenance purposes.

VII

For and in consideration of the addition of the land to the District, Petitioners agree that the covenants contained herein shall become fixed with the land, shall run with the land, and shall be binding on Petitioners, their successors, and assigns.

WHEREFORE, Petitioners pray that this petition be properly filed, as provided by law; that it be set down for a hearing at a date to be fixed in keeping with the provisions of said Chapters 49 and 54, Texas Water Code; that notice of such hearing be given and this petition in all things be granted and that the land described in Exhibit A be added to and become a part of the established North Mission Glen Municipal Utility District of Fort Bend County, Texas; that the order of the Board granting this petition be filed of record in the Deed Records of Fort Bend County, Texas; and that the area described in Exhibit A thereafter be part of North Mission Glen Municipal Utility District of Fort Bend County, Texas

EXECUTED this _____ day of _____, 1999

WORLDSCO COMPANY, LTD. a Texas
limited partnership

By: _____
Name: Anthony Chan
Title: General Partner

STATE OF CALIFORNIA
COUNTY OF _____

BEFORE ME, the undersigned, on this day personally appeared Anthony Chan as the General Partner of Worldco Company, Ltd., known to me to be the person whose name is subscribed to the foregoing instrument, and acknowledged to me that he executed the same for the purposes and consideration therein expressed, in the capacity stated, and as the act and deed of said Worldco Company, Ltd.

GIVEN UNDER MY HAND AND SEAL OF OFFICE this the ____ day of _____, 1999

Notary Public, State of California

Name, Expiration Date, and Seal

FORT BEND COUNTY

By: J.C.E.
Name: James C. Adolphus
Title: County Judge

STATE OF TEXAS
COUNTY OF FORT BEND

BEFORE ME, the undersigned, on this day personally appeared James C Adolphus as County Judge of Fort Bend County, known to me to be the person whose name is subscribed to the foregoing instrument, and acknowledged to me that he executed the same for the purposes and consideration therein expressed, in the capacity stated, and as the act and deed of said County.

GIVEN UNDER MY HAND AND SEAL OF OFFICE this the 13 day of October, 1999.

Ann Werlein
Notary Public, State of Texas

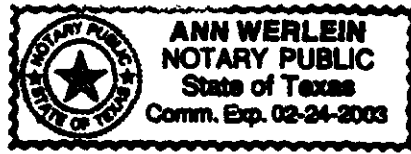

Name, Expiration Date, and Seal

A tract of land containing 103.1320 acres, more or less, being situated in and being a part of Lot 9 and all of Lot 8 of the Brown Brothers Subdivision in the John Leverton Survey, Abstract 402, Fort Bend County, Texas, and being more particularly described as follows:

A 103.1320-acre tract of land, being Lot 8 and a part of Lot 9, of Brown Brothers Subdivision in the John Leverton Survey, Abstract 402, Fort Bend County, Texas, and being that same tract of land described in deed recorded in Volume 563, Page 792, dated April 14, 1972, Deed Records, Fort Bend County, Texas.

BEGINNING at a 1/2 inch iron rod found on the Westerly right-of-way line of Gains Road, at the Northeast corner of Lot 8, Brown Brothers Subdivision, for the Northeast corner and PLACE OF BEGINNING of the herein described 103.1320-acre tract of land;

THENCE South 89 deg. 29 min. 21 sec. West, along a fence line being the North line of the herein described 103.1320-acre tract, same being a common line to the Schumann Estate 542.4581-acre tract, 2307.49 feet to a creosote post set in concrete for the northwest corner of the herein described 103.1320-acre tract, same being a reentry corner of the P. E. Schumann 542.4581-acre tract;

THENCE South 01 deg. 07 min. 17 sec. East, along a fence line being a common line of the herein described 103.1320-acre tract and the P. E. Schumann tract, 2106.09 feet to a 3/4 inch iron pipe found for the Southwest corner of the herein described 103.1320-acre tract, said point also being the Northeast corner of the D. A. Conner Survey, Abstract 153, and a reentry corner to the John Leverton Survey, Abstract 402;

THENCE North 88 deg. 43 min. 56 sec. East, along a fence line as located on the South line of the herein described 103.1320-acre tract, 1987.53 feet to a 3/4-inch iron pipe set at its point of intersection with the Westerly line of Gains Road for the Southeast corner of the herein described 103.1320-acre tract;

THENCE North 07 deg. 38 min. 06 sec. East, along the Westerly line of Gains Road, 2100.92 feet to the PLACE OF BEGINNING and containing 103.1320 acres of land.

PETITION FOR CONSENT TO ANNEX LAND
TO A MUNICIPAL UTILITY DISTRICT

STATE OF TEXAS
COUNTY OF FORT BEND

TO THE HONORABLE MAYOR AND CITY COUNCIL OF THE CITY OF HOUSTON,
TEXAS

The undersigned, North Mission Glen Municipal Utility District of Fort Bend County, Texas (the "District"), and Worldco Company, Ltd., and Fort Bend County (collectively referred to herein as the "Parties"), acting pursuant to the provisions of Chapters 49 and 54, Texas Water Code, respectfully petition the City Council of the City of Houston, Texas, for its written consent to the annexation by the District of the tract of land described by metes and bounds in Exhibit A attached hereto. In support of this petition, the undersigned would show the following:

I

The District was originally created as a municipal utility district by the Texas Water Commission (now the Texas Natural Resource Conservation Commission) on 10 December 1980 and is governed by the provisions of Chapters 49 and 54, Texas Water Code.

II

The Parties hold title to the land sought to be annexed to the District, as indicated by the tax rolls of Fort Bend County, Texas. The Parties hold fee simple title to the tracts of land described in Exhibit A attached hereto. The Parties are the only owners on the tract of land, and there are no lienholders on the land.

III

The land sought to be annexed to the District is comprised of one tract totalling approximately 103.132 acres of land, more or less, situated wholly within Fort Bend County, Texas. No part of said tract is within the limits of any incorporated city, town, or village, and no part of said tract is within the extraterritorial jurisdiction (as such term is defined in Texas Local Government Code) of any city, town, or village except the City of Houston, Texas. All of the territory proposed to be annexed may properly be annexed to the District.

IV

The land sought to be annexed to the District is described by metes and bounds in Exhibit A which is attached hereto and incorporated herein for all purposes.

V

The general nature of the work to be done in the area sought to be annexed to the District is the construction, acquisition, maintenance, and operation of a waterworks and sanitary sewer system for residential and commercial purposes and the construction, acquisition, maintenance, and operation of a drainage system to gather, conduct, divert, and control local storm water or other local harmful excesses of water.

VI

There is, for the following reasons, a necessity for the above-described work. The area proposed to be annexed to the District will be developed as residential property, is urban in nature, is within the growing environs of Houston, is in close proximity to populous and developed sections of Fort Bend County, and within the immediate future will experience a substantial and sustained growth. There is not now available within the area sought to be annexed to the District an adequate waterworks and sanitary sewer system nor an adequate drainage system, and it is not presently economically feasible for the area sought to be annexed to provide for such systems without the assistance of the District. Since the health and welfare of the present and future inhabitants of the area and of territories adjacent thereto require the construction, acquisition, maintenance, and operation of an adequate waterworks and sanitary sewer system and a drainage system, a public necessity exists for the annexation of the aforementioned lands to the District, to provide for the purchase, construction, extension, improvement, maintenance, and operation of such waterworks and sanitary sewer system and such drainage system, so as to promote the purity and sanitary condition of the State's waters and the public health and welfare of the community.

VII

The undersigned request consent to the annexation of the aforesaid land to the District under the conditions set forth in Exhibit B, which is attached hereto and incorporated herein for all purposes, until such time as said conditions may be changed by City Ordinance or resolution, either specific or general

VIII

The District agrees and hereby covenants that if the requested consent to the annexation of the aforesaid land to the District is given, the District will adopt and abide by the conditions set forth in Exhibit B to this petition.

IX.

The undersigned estimate, from such information as they have at this time, that the cost to extend the District's facilities to serve the area sought to be annexed will be \$5,620,000 (reimbursable construction and engineering costs).

WHEREFORE, the undersigned respectfully pray that this petition be heard and granted in all respects and that the City of Houston give its written consent to the annexation of the aforesaid land to the District.

RESPECTFULLY SUBMITTED this ____ day of _____, 1999.

President, Board of Directors
North Mission Glen Municipal Utility
District of Fort Bend County, Texas

ATTEST:

Secretary, Board of Directors
North Mission Glen Municipal Utility
District of Fort Bend County, Texas

(SEAL)

STATE OF TEXAS
COUNTY OF FORT BEND

BEFORE ME, the undersigned, on this day personally appeared J Keith Parker as President of the Board of Directors of North Mission Glen Municipal Utility District, known to me to be the person whose name is subscribed to the foregoing instrument, and acknowledged to me that he executed the same for the purposes and consideration therein expressed, in the capacity stated, and as the act and deed of said District.

GIVEN UNDER MY HAND AND SEAL OF OFFICE this the ____ day of _____, 1999.

Notary Public, State of Texas

Name, Expiration Date, and Seal

WORLDSCO COMPANY, LTD. a Texas
limited partnership

By: _____
Name: Anthony Chan
Title: General Partner

STATE OF CALIFORNIA
COUNTY OF _____

BEFORE ME, the undersigned, on this day personally appeared Anthony Chan as the General Partner of Worldco Company, Ltd., known to me to be the person whose name is subscribed to the foregoing instrument, and acknowledged to me that he executed the same for the purposes and consideration therein expressed, in the capacity stated, and as the act and deed of said Worldco Company, Ltd.

GIVEN UNDER MY HAND AND SEAL OF OFFICE this the ____ day of _____, 1999.

Notary Public, State of California

Name, Expiration Date, and Seal

(for street rights-of-way)

FORT BEND COUNTY

By: J. C. R.
Name: James C. Adolphus
Title: County Judge

STATE OF TEXAS
COUNTY OF FORT BEND

BEFORE ME, the undersigned, on this day personally appeared James C. Adolphus as County Judge of Fort Bend County, known to me to be the person whose name is subscribed to the foregoing instrument, and acknowledged to me that he executed the same for the purposes and consideration therein expressed, in the capacity stated, and as the act and deed of said County

GIVEN UNDER MY HAND AND SEAL OF OFFICE this the 13 day of October, 1999.

Ann Werlein
Notary Public, State of Texas

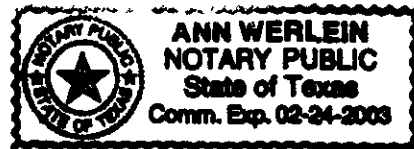

Name, Expiration Date, and Seal

A tract of land containing 103.1320 acres, more or less, being situated in and being a part of Lot 9 and all of Lot 8 of the Brown Brothers Subdivision in the John Leverton Survey, Abstract 402, Fort Bend County, Texas, and being more particularly described as follows:

A 103.1320-acre tract of land, being Lot 8 and a part of Lot 9, of Brown Brothers Subdivision in the John Leverton Survey, Abstract 402, Fort Bend County, Texas, and being that same tract of land described in deed recorded in Volume 563, Page 792, dated April 14, 1972, Deed Records, Fort Bend County, Texas.

BEGINNING at a 1/2 inch iron rod found on the Westerly right-of-way line of Gains Road, at the Northeast corner of Lot 8, Brown Brothers Subdivision, for the Northeast corner and PLACE OF BEGINNING of the herein described 103.1320-acre tract of land;

THENCE South 89 deg. 29 min. 21 sec. West, along a fence line being the North line of the herein described 103.1320-acre tract, same being a common line to the Schumann Estate 542.4581-acre tract, 2307.49 feet to a creosote post set in concrete for the northwest corner of the herein described 103.1320-acre tract, same being a reentry corner of the P. E. Schumann 542.4581-acre tract;

THENCE South 01 deg. 07 min. 17 sec. East, along a fence line being a common line of the herein described 103.1320-acre tract and the P. E. Schumann tract, 2106.09 feet to a 3/4 inch iron pipe found for the Southwest corner of the herein described 103.1320-acre tract, said point also being the Northeast corner of the D. A. Conner Survey, Abstract 153, and a reentry corner to the John Leverton Survey, Abstract 402;

THENCE North 88 deg. 43 min. 56 sec. East, along a fence line as located on the South line of the herein described 103.1320-acre tract, 1987.53 feet to a 3/4-inch iron pipe set at its point of intersection with the Westerly line of Gains Road for the Southeast corner of the herein described 103.1320-acre tract;

THENCE North 07 deg. 38 min. 06 sec. East, along the Westerly line of Gains Road, 2100.92 feet to the PLACE OF BEGINNING and containing 103.1320 acres of land.



EXHIBIT "B"

(a) The District will issue bonds only for the purpose of purchasing and constructing, or purchasing or constructing under contract with the City of Houston, or otherwise acquiring waterworks systems, sanitary sewer systems, storm sewer systems, and drainage facilities, or parts of such systems or facilities, and to make any and all necessary purchases, construction, improvements, extensions, additions, and repairs thereto, and to purchase or acquire all necessary land, right-of-way, easements, sites, equipment, buildings, plants, structures, and facilities therefor, and to operate and maintain same, and to sell water, sanitary sewer, and other services within or without the boundaries of the District. Such bonds will expressly provide that the District reserves the right to redeem the bonds on any interest-payment date subsequent to the fifteenth (15th) anniversary of the date of issuance without premium and will be sold only after the taking of public bids therefor, and none of such bonds, other than refunding bonds, will be sold for less than 95% of par; provided that the net effective interest rate on bonds so sold, taking into account any discount or premium as well as the interest rate borne by such bonds, will not exceed two percent (2%) above the highest average interest rate reported by the *Daily Bond Buyer* in its weekly "20 Bond Index" during the one-month period next preceding the date notice of the sale of such bonds is given, and that bids for the bonds will be received not more than forty-five (45) days after notice of sale of the bonds is given. The resolution authorizing the issuance of the District's bonds will contain a provision that any pledge of the revenues from the operation of the District's water and sewer and/or drainage system to the payment of the District's bonds will terminate when and if the City of Houston, Texas, annexes the District, takes over the assets of the District and assumes all of the obligations of the District. No land located within the extraterritorial jurisdiction of the City of Houston will be added or annexed to the District until the City of Houston has given its written consent by resolution or ordinance of the City Council to such addition or annexation.

(b) Before the commencement of any construction within the District, its directors, officers, or developers and landowners will submit to the Director of the Department of Public Works and Engineering of the City of Houston, or to their designated representatives, all plans and specifications for the construction of water, sanitary sewer, and drainage facilities to serve the District and obtain the approval of such plans and specifications therefrom. All water wells, water meters, flushing valves, valves, pipes, and appurtenances thereto, installed or used within the District, will conform exactly to the specifications of the City of Houston. All water service lines and sewer service lines, lift stations, sewage treatment facilities, and appurtenances thereto, installed or used within the District will comply with the City of Houston's standard plans and specifications as amended from time to time. Prior to the construction of such facilities within or by the District, the District or its engineer will give written notice by registered or certified mail to the Director of Public Works and Engineering, stating the date that such construction will be commenced. The construction of the District's water, sanitary sewer, and drainage

facilities will be in accordance with the approved plans and specifications, and with applicable standards and specifications of the City of Houston; and during the progress of the construction and installation of such facilities, the Director of Public Works and Engineering of the City of Houston, or an employee thereof, may make periodic on-the-ground inspections.

(c) The District will agree to employ a sewage plant operator holding a valid certificate of competency issued under the direction of the Texas Department of Health as required by Article 4477-1, §20(a), Tex. Rev. Civ. Stat. Ann. (Vernon Supp. 1994). The District will agree to make periodic analyses of its discharge pursuant to the provisions of Order No. 69-1219-1 of the Texas Water Quality Board (now, the Texas Natural Resources Conservation Commission) and further to send copies of all such effluent data to the Department of Public Works and Engineering, City of Houston, as well as to the TNRCC. The District will agree that representatives of the City of Houston may supervise the continued operations of the sewage treatment facility by making periodic inspections thereof.

(d) The District, its board of directors, officers, developers, and/or landowners will not permit the construction, or commit to any development within, the District that will result in a wastewater flow to the serving treatment facility which exceeds that facility's legally permitted average daily flow limitations or the District's allocated capacity therein.

(e) Prior to the sale of any lot or parcel of land, the owner or the developer of the land included within the limits of the District will obtain the approval of the Planning Commission of the City of Houston of a plat which will be duly recorded in the Map and Plat Records of Harris County, Texas, and otherwise comply with the rules and regulations of the Department of Planning and Development and the Department of Public Works and Engineering of the City of Houston.

8

AGENDA
OCTOBER 12, 1999

TO: MANDI

FROM: PAULETTE

10/12/99 10:30 AM

1. A Approve application from G T.E to bury cable along Juliff-Manville Road, Pct.2.
2. B Approve application from Southwestern Bell Telephone Company to bury cable along Skinner Road, Pct 3.
3. C Set public hearing for acceptance of the traffic control plans for Avenue "E " Stafford Area, 5th Street Stafford Area, and Dove Country Subdivision, Pct 1 and Pct 3
4. D Set public hearing for acceptance of traffic control plan for Lexington Settlement Subdivision, Pct. 3.
5. E Approve the plat for Texana Plantation, Section 3, Pct. 3
6. F Approve the plat for Sienna Village of Waters Lake, Section 7-A, Pct 2
7. G Approve the plat for Greatwood Wood Creek, Pct. 1.
8. H Approve the plat for Greatwood Fairview, Pct 1.
9. I Approve the plat for Greatwood Stonebridge, Pct. 1
10. J Approve the plat for Greatwood Brooks Mills, Pct 1
11. K Approve the plat for Greatwood Shadow Bend Drive, Winding Book East Drive and Winding Brook West Drive Street Dedication, Pct 1

REVIEW BY FORT BEND COUNTY COMMISSIONERS COURT

On this 12 day of October, 19 99, before the Fort Bend County Commissioners Court came on to be heard and reviewed the accompanying notice of G.T.E.

Job Location Juliff-Menville Road

Dated 9-29-99 Bond No. 82781, Permit No. 82166

to make use of certain Fort Bend County property subject to, "A Revised Order Regulating the Laying, Construction, Maintenance, and Repair of Buried Cables, Conduits and Pole Lines, In, Under, Across or Along Roads, Streets, Highways and Drainage Ditches in Fort Bend County, Texas, Under the Jurisdiction of the Commissioners Court of Fort Bend County, Texas," as passed by the Commissioners Court of Fort Bend County, Texas, dated the 3rd day of August, 1987, recorded in Volume _____ of the Minutes of the Commissioners Court of Fort Bend County, Texas, to the extent that such order is not inconsistent with Article 1436a, Vernon's Texas Civil Statutes. Upon Motion of Commissioner Prestage, seconded by Commissioner D'Shieles, duly put and carried, it is ORDERED, ADJUDGED AND DECREED that said notice of said above purpose is hereby acknowledged by the Commissioners Court of Fort Bend County, Texas, and that said notice be placed on record according to the regulation order thereof

Notes:

- 1 Evidence of review by the Commissioners Court must be kept on the jobsite and failure to do so constitutes grounds for job shutdown.
- 2. Written notices are required:
 - a) 48 hours in advance of construction start up, and
 - b) When construction is completed and ready for final inspection

Mail notices to. Permit Administrator
Fort Bend County Engineering
P O. Box 1449
Rosenberg, Texas 77471-1449
281/342-3039

- 3 This permit expires one (1) year from date of permit if construction has not commenced.

By [Signature]
County Engineer

Presented to Commissioners Court and approved.
Recorded in Volume _____
Minutes of Commissioners Court.

By _____
Drainage District Engineer/Manager

Clerk of Commissioners Court
By [Signature]
Deputy

COUNTY OF FORT BEND

Engineering Department

P O Box 1449
Rosenberg, TX 77471-1449

Johnny Ortega
Permit Administrator

1124 Blume Rd
Phone. (281)342-3039

PERMIT APPLICATION REVIEW FORM FOR CABLE, CONDUIT, AND POLE LINE ACTIVITY IN FORT BEND COUNTY

PERMIT NO 082166

The following "Notice of Proposed Cable, Conduit, and/or Pole Line activity in Fort Bend County" and accompanying attachments have been reviewed and the notice conforms to appropriate regulations set by Commissioners' Court of Fort Bend County, Texas

- / (1) Complete Application Form
- / a Name of road, street, and/or drainage ditch affected
 - / b Vicinity map showing course of direction
 - / c Plans and specifications

- / (2) Bond _____
- _____ District Attorney, approval when applicable
- / Perpetual bond currently posted
- No 82781
- Amount 150,000.
- _____ Performance bond submitted
- No _____
- Amount _____
- _____ Cashier's Check
- No _____
- Amount _____

- _____ (3) Verbal permission given for emergencies, to start construction before approved in Commissioners' Court

_____ Precinct Engineer Acknowledgement

_____ Date

_____ Precinct Commissioner Acknowledgement

_____ Date

- / (4) _____
- Drainage District Approval when applicable

We have reviewed this project and agree it meets minimum requirements

Johnny Ortega CFM/ Permit Administrator

9/29/99
Date

NOTICE OF PROPOSED CABLE, CONDUIT AND/OR POLE LINE ACTIVITY
IN, UNDER, ACROSS OR ALONG ROADS, STREETS, HIGHWAYS AND DRAINAGE DITCHES
IN FORT BEND COUNTY

APPLICANT'S JOB NO. 7FOOIAK
 PERMIT NO. 82166 PCT. NO. 2
 BOND NO. 82781

Formal notice is hereby given that GTE
 proposes to lay, construct, maintain and/or repair cable, conduit and/or pole
 line, in, under, across, or along roads, streets, highways and drainage
 ditches in Fort Bend County, as follows:

In, Under, or Across Roads and/or Drainage Ditches

Road or Ditch Name	Distance & Direction From Nearest Intersection	Length of Crossing	Type of Construction			
			Bored	Jacked	Driven	Cased

Along Roads and/or Drainage Ditches

Road or Ditch Name	Distance & Direction From Nearest Intersection	To	Distance
JULIFF- MANVILLE RD:	Fm 521	BRAZORIA CO. LINE	5232'

General Description

BURY FIBER CABLE ALONG THE NORTH SIDE OF
 JULIFF-MANVILLE RD 12 FT FROM THE EDGE
 OF GRAVEL/PAVEMENT FOR A DISTANCE OF 5232'
 FM 521 TO THE BRAZORIA COUNTY LINE

The location and description of the proposed installation and appurtenances is more fully shown on the attached detail drawings. The laying, construction, maintenance and/or repair of the proposed installation shall be subject to "A Revised Order Regulating the Laying, Construction, Maintenance and/or Repair of Cables, Conduits, and/or Pole Lines, In, Under, Across, or Along Roads, Streets, Highways and Drainage Ditches in Fort Bend County, Texas, Under the Jurisdiction of the Commissioners Court of Fort Bend County, Texas," as passed by Commissioners Court of Fort Bend County, Texas, dated the 3rd. day of August, 1987, recorded in Volume 639 of the Minutes of the Commissioners Court of Fort Bend County, Texas.

Written notices are required: 1) 48 hours in advance of start of construction and 2) when construction is complete and ready for final inspection

Mail To: Permit Administrator/Fort Bend County Engineering
 P. O. Box 1449, Rosenberg, Texas 77471

Violation of requirements shall constitute grounds for job shut down.

COMPANY NAME: _____
 AGENT and/or OWNER

 (Signature)

NAME & TITLE _____
 (Please Print)

DATE: _____

ADDRESS: _____
 (Street/P.O. Box)

City _____ State _____ Zip _____

TELEPHONE NO: _____
 (accessible 24 hrs/day, 7 days/week)

AS PER ORIGINAL

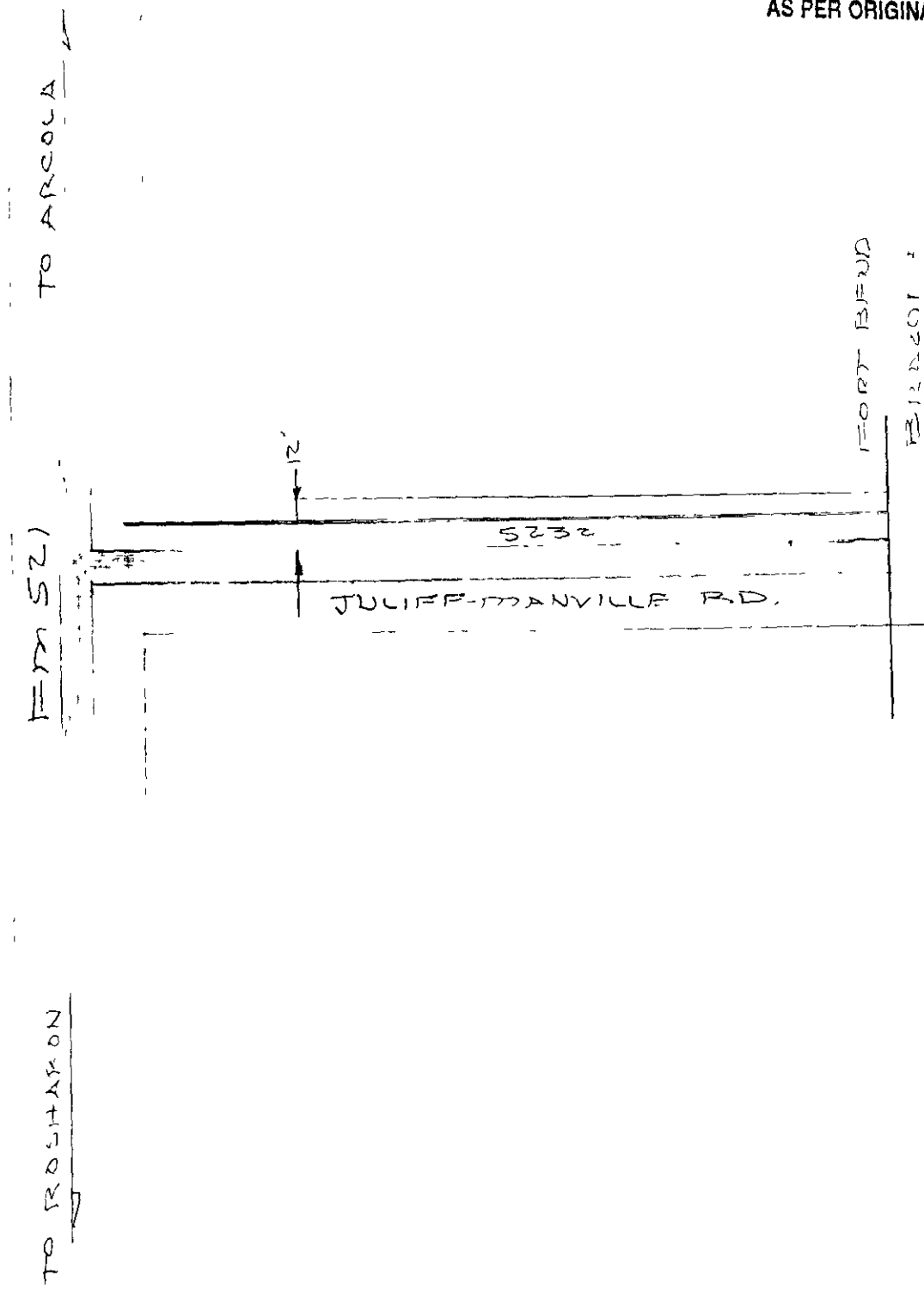

AREA	
TAX CAST	
ENGINEERED BY	DATE
DRAWN BY	DATE
APPROVED BY	DATE
REVISED BY	DATE



GTE Telephone Operations	
LOCATION	ARCOVA
DESCRIPTION	FORT BEND PERMIT
SHEET 1 OF 1	WO NO 7FOO/AK

REVIEW BY FORT BEND COUNTY COMMISSIONERS COURT

On this 12 day of October, 19 99, before the Fort Bend County Commissioners Court came on to be heard and reviewed the accompanying notice of Southwestern Bell Telephone Company
Job Location Skinner Road
Dated 9-29-99 Bond No. 5893554, Permit No. 82165

to make use of certain Fort Bend County property subject to, "A Revised Order Regulating the Laying, Construction, Maintenance, and Repair of Buried Cables, Conduits and Pole Lines, In, Under, Across or Along Roads, Streets, Highways and Drainage Ditches in Fort Bend County, Texas, Under the Jurisdiction of the Commissioners Court of Fort Bend County, Texas," as passed by the Commissioners Court of Fort Bend County, Texas, dated the 3rd day of August, 1987, recorded in Volume _____ of the Minutes of the Commissioners Court of Fort Bend County, Texas, to the extent that such order is not inconsistent with Article 1436a, Vernon's Texas Civil Statutes. Upon Motion of Commissioner Prestage, seconded by Commissioner O'Shieles, duly put and carried, it is ORDERED, ADJUDGED AND DECREED that said notice of said above purpose is hereby acknowledged by the Commissioners Court of Fort Bend County, Texas, and that said notice be placed on record according to the regulation order thereof

Notes:

- 1 Evidence of review by the Commissioners Court must be kept on the jobsite and failure to do so constitutes grounds for job shutdown.
- 2. Written notices are required.
 - a) 48 hours in advance of construction start up, and
 - b) When construction is completed and ready for final inspection

Mail notices to: Permit Administrator
Fort Bend County Engineering
P.O. Box 1449
Rosenberg, Texas 77471-1449
281/342-3039

- 3. This permit expires one (1) year from date of permit if construction has not commenced.

By [Signature]
County Engineer

Presented to Commissioners Court and approved.
Recorded in Volume _____
Minutes of Commissioners Court.

By _____
Drainage District Engineer/Manager

Clerk of Commissioners Court
By [Signature]
Deputy

COUNTY OF FORT BEND

Engineering Department

P O Box 1449
Rosenberg, TX 77471-1449

Johnny Ortega
Permit Administrator

1124 Blume Rd
Phone (281)342-3039

PERMIT APPLICATION REVIEW FORM FOR CABLE, CONDUIT, AND POLE LINE ACTIVITY IN FORT BEND COUNTY

PERMIT NO 082165

The following "Notice of Proposed Cable, Conduit, and/or Pole Line activity in Fort Bend County" and accompanying attachments have been reviewed and the notice conforms to appropriate regulations set by Commissioners' Court of Fort Bend County, Texas

- (1) Complete Application Form.
- a Name of road, street, and/or drainage ditch affected
 - b Vicinity map showing course of direction
 - c Plans and specifications

- (2) Bond _____
- District Attorney, approval when applicable
- Perpetual bond currently posted
No 5893554
Amount 50,000.
- Performance bond submitted
- No _____
Amount _____
- Cashier's Check
- No _____
Amount _____

- _____ (3) Verbal permission given for emergencies, to start construction before approved in Commissioners' Court

Precinct Engineer Acknowledgement

Date

Precinct Commissioner Acknowledgement

Date

- _____ (4) _____
Drainage District Approval when applicable

We have reviewed this project and agree it meets minimum requirements



Johnny Ortega CFM/ Permit Administrator

9/29/99

Date

NOTICE OF PROPOSED CABLE, CONDUIT AND/OR POLE LINE ACTIVITY
IN, UNDER, ACROSS OR ALONG ROADS, STREETS, HIGHWAYS AND DRAINAGE DITCHES
IN FORT BEND COUNTY

APPLICANT'S JOB NO. 4700151
 PERMIT NO. 8216S PCT. NO. 3
 BOND NO. 5893554

Formal notice is hereby given that Southwestern Bell Telephone Company proposes to lay, construct, maintain and/or repair cable, conduit and/or pole line, in, under, across, or along roads, streets, highways and drainage ditches in Fort Bend County, as follows:

In, Under, or Across Roads and/or Drainage Ditches

Road or Ditch Name	Distance & Direction From Nearest Intersection	Length of Crossing	Type of Construction Bored Tacked Driven Cased

Along Roads and/or Drainage Ditches

Road or Ditch Name	Distance & Direction From Nearest Intersection	To	Distance
Skinner Road	800' north of FM 359	South	350'

General Description

Place buried telephone cable east side of Skinner Rd. to provide telephone service in Pecan Grove Plantation Subdivision.

The location and description of the proposed installation and appurtenances is more fully shown on the attached detail drawings. The laying, construction, maintenance and/or repair of the proposed installation shall be subject to "A Revised Order Regulating the Laying, Construction, Maintenance and/or Repair of Cables, Conduits, and/or Pole Lines, In, Under, Across, or Along roads, Streets, Highways and Drainage Ditches in Fort Bend County, Texas, Under the Jurisdiction of the Commissioners Court of Fort Bend County, Texas," as passed by Commissioners Court of Fort Bend County, Texas, dated the 31d. day of August, 1987, recorded in Volume 639 of the Minutes of the Commissioners Court of Fort Bend County, Texas

Written notices are required: 1) 48 hours in advance of start of construction and 2) when construction is complete and ready for final inspection

Mail To: Permit Administrator/Fort Bend County Engineering
 P. O. Box 1449, Rosenberg, Texas 77471

Violation of requirements shall constitute grounds for job shut down.

COMPANY NAME. SOUTHWESTERN BELL TELEPHONE CO.
 AGENT and/or OWNER

R. L. Jones
 (Signature)

NAME & TITLE R. L. Jones, Mgr.-Eng. Design
 (Please Print)

DATE. 9-17-99

ADDRESS: 1110 Louise, 1st Floor
 (Street/P.O. Box)

Rosenberg Texas 77471
 City State Zip

TELEPHONE NO: 281-341-4312
 (accessible 24 hrs/day, 7 days/week)

OPERATING INSTRUCTIONS

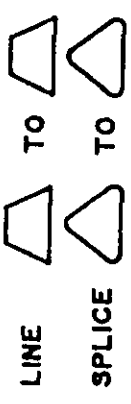

MFRC _____

TRANSMISSION ZONE _____

RZ _____ CZ _____

TAPER CODE _____

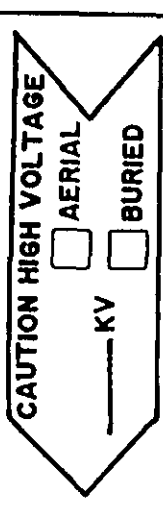

SPECIAL CIRCUITS INVOLVED

YES NO

6203 FORWARDED

YES NO

PERMIT REQUIRED

YES NO

POLE CONTACTS

(+) _____ OR (-) _____

PWR. CO. _____

NOTES

ORDER NO. 4700151

TOT. PLATS _____ FLAT NO. _____

C.O. _____

EXCH. _____

TAX DIST. _____

GEO. LOC. _____

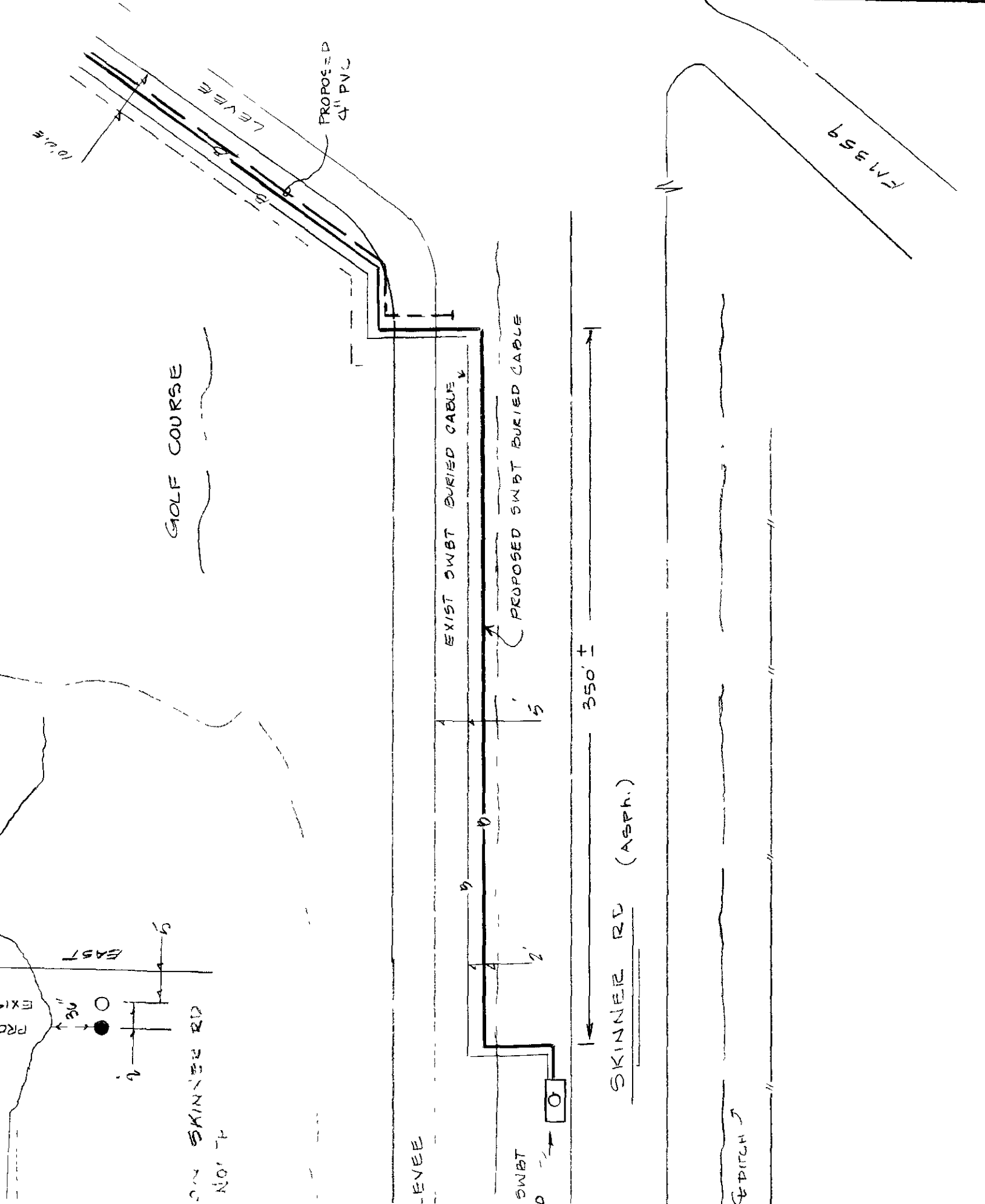

**FORT BEND COUNTY
COMMISSIONERS COURT AGENDA REQUEST FORM
RETURN TO: AGENDA COORD.-COUNTY JUDGE'S OFFICE**

DATE SUBMITTED: October 4, 1999 SUBMITTED BY: Bouche Mickey AGENDA
 DEPARTMENT: Extension Service ITEM
 COURT AGENDA DATE: October 12, 1999 PHONE NO.: (281)342-3034 # 9

SUMMARY OF ITEM:

Approval for Payment of Invoice #5 for Architectural Services to Don A. Hartfiel.
 Purchase Order Number - PC00100000627

RENEWAL CONTRACT/AGREEMENT: Yes () No ()

LIST SUPPORTING DOCUMENTS ATTACHED: 10-05-99-03 15 20

FINANCIAL SUMMARY:

BUDGETED ITEM:	ANNUALIZED DOLLARS:	COMMENTS:
Yes () No () N/A ()	One Time ()	
Funding Source: fund _____ agcy _____ Object _____	Recurring ()	
	N/A ()	

Original Form Submitted with back up to County Judge's Office: Yes ()

CC with back up:

yes () Auditor	(281-341-3774)	yes () Comm. Pct. 1	(281-342-0587)
yes () Budget Officer	(281-344-3954)	yes () Comm. Pct. 2	(281-403-8009)
yes () County Attorney	(281-341-4557)	yes () Comm. Pct. 3	(281-242-9060)
yes () Purchasing Agent	(281-341-8642)	yes () Comm. Pct. 4	(281-980-9077)

Instructions for submitting an Agenda Request:

1. Completely fill out agenda form, incomplete forms will not be processed.
2. Fax or inter-office copies of agenda form with all back up information by Wednesday at 2:00 p.m. to the departments listed above.
3. All original back-up must be received in the County Judges Office by 2:00 p.m. on Wednesday.

RECOMMENDATION / ACTION REQUESTED:

INVOICE FOR ARCHITECTURAL SERVICE

PROJECT: FORT BEND COUNTY AGRICULTURE
CENTER
BAND ROAD
ROSENBERG, TEXAS

10-00-00P03 13

DATE: SEPTEMBER 14, 1999

INVOICE NO: FIVE

TO: MR. BUSCHE MICKEY
FORT BEND COUNTY EXTENSION SERVICE
1436 BAND ROAD
ROSENBERG, TEXAS 77471

There is due at this time for architectural services and reimbursable items on the above Project, the sum of:

Dollars \$ 10,000.00

The present status of the account is as follows:

FORT BEND COUNTY P.O. NUMBER - PC00100000627

ARCHITECTURAL SERVICES - 8/3/99 THRU 9/12/99

CONSTRUCTION DOCUMENT PHASE IN PROGRESS -
PLAN REVISIONS COMPLETED, ARCHITECTURAL, MEP AND CIVIL
ENGINEERING DRAWINGS IN PROGRESS.

ARCHITECTURAL FEE PROGRESS PAYMENT DUE THIS INVOICE

\$10,000.00

DON A. HARTFIEL AIA ARCHITECT
POST OFFICE BOX 638
RICHMOND, TEXAS 77406-0638

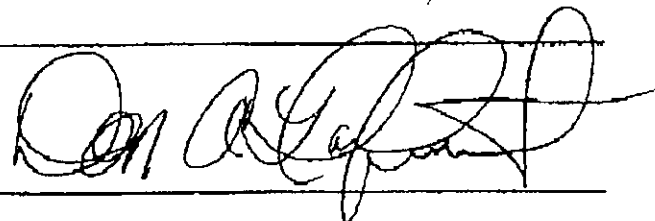

Busche Mickey
)))

**FORT BEND COUNTY
COMMISSIONERS COURT AGENDA REQUEST FORM
RETURN TO: AGENDA COORD.-COUNTY JUDGE'S OFFICE**

DATE SUBMITTED: 9 28 99

SUBMITTED BY: Dennis Mc Mahon

AGENDA

COURT AGENDA DATE: 10/12/99

DEPARTMENT: Risk Management
PHONE NO: (281) 341 8630

ITEM

10A

SUMMARY OF ITEM:

CONSENT AGENDA

Consider accepting and approving the 2000 annual letter of exemption for the Health Insurance Portability and Accountability Act of 1996.

RENEWAL CONTRACT/AGREEMENT: Yes () No

LIST SUPPORTING DOCUMENTS ATTACHED: HIPAA Exemption Election Document

FINANCIAL SUMMARY:

BUDGETED ITEM:	ANNUALIZED DOLLARS.	COMMENTS:
Yes () No () N/A ()	One Time ()	
Funding Source. fund _____ agcy _____ Object _____	Recurring ()	
	N/A ()	

Original Form Submitted with back up to County Judge's Office: Yes ()

CC with back up:

yes <input checked="" type="checkbox"/> Auditor	(281-341-3774)	yes <input checked="" type="checkbox"/> Comm. Pct. 1	(281-342-0587)
yes <input checked="" type="checkbox"/> Budget Officer	(281-344-3954)	yes <input checked="" type="checkbox"/> Comm. Pct. 2	(281-403-8009)
yes <input checked="" type="checkbox"/> County Attorney	(281-341-4557)	yes <input checked="" type="checkbox"/> Comm. Pct. 3	(281-242-9060)
yes <input checked="" type="checkbox"/> Purchasing Agent	(281-341-8642)	yes <input checked="" type="checkbox"/> Comm. Pct. 4	(281-980-9077)

Instructions for submitting an Agenda Request:

1. Completely fill out agenda form, incomplete forms will not be processed.
2. Fax or inter-office copies of agenda form with all back up information by Wednesday at 2:00 p.m. to the departments listed above.
3. All original back-up must be received in the County Judges Office by 2:00 p.m. on Wednesday.

RECOMMENDATION / ACTION REQUESTED:

10-12-99

*Original Letter of Exemption
was given to Risk Management
by County Judges Office.*

HIPAA Exemption Election Document

Name of Plan Fort Bend County Employee Benefit Plan
Plan Sponsor Fort Bend County
EIN 74-6001969 Plan Number N/A
Plan Year January 01, 2000 through December 31, 2000

Plan Administrator	Fort Bend County	Contract Administrator
Address	Attn County Attorney 309 S 4 th Street, Suite 621 Richmond, Texas 77469 281-341-4555	Health Administration Services, Inc P O Box 672448 Houston, Texas 77267-2448

Fort Bend County Employee Benefit Plan is not provided through insurance Fort Bend County elects under authority of section 2721(b)(2) of the Public Health Service Act (PHS Act), and 45 CFR 146 180 of Federal regulations to exempt Fort Bend County Employee Benefit Plan from the following HIPAA requirements and the PHS Act, as amended.

- 1 Limitations of pre-existing condition exclusion periods
- 2 Special enrollment periods
- 3 Prohibitions against discriminating against individual participants and beneficiaries based on health status
- 4 Standards relating to benefits for mothers and newborns
- 5 Party in the application of certain limits to mental health benefits
- 6 Required coverage for reconstructive surgery following mastectomies

This election has been made in conformity with all rules of the plan sponsor including any public hearing, if required I certify that the undersigned is authorized to submit this election on behalf of Fort Bend County Employee Benefit Plan A copy of the notice to plan enrollees is enclosed

This election was made at a duly called open meeting of the Fort Bend County Commissioners Court on October 12 1999 at Richmond, Texas

Signature
County Judge
Title

**FORT BEND COUNTY
COMMISSIONERS COURT AGENDA REQUEST FORM
RETURN TO: AGENDA COORD.-COUNTY JUDGE'S OFFICE**

DATE SUBMITTED: 10/5/99 SUBMITTED BY: Sandy Kucera AGENDA
 DEPARTMENT: Risk Management ITEM
 COURT AGENDA DATE: 10/12/99 PHONE NO.: (281) 341 8630 #10B

SUMMARY OF ITEM: CONSENT AGENDA ITEM:

Consider authorizing payments for damages to County vehicles, non-County vehicles, and County property.

RENEWAL CONTRACT/AGREEMENT: Yes () No

LIST SUPPORTING DOCUMENTS ATTACHED: Gallagher Bassett summary and information

FINANCIAL SUMMARY:

BUDGETED ITEM	ANNUALIZED DOLLARS	COMMENTS
Yes <input checked="" type="checkbox"/> No () N/A ()	One Time ()	403 068 0682 1010 \$ 3124.00
Funding Source:	Recurring ()	403 068 0682 7100 \$ 2227.80
fund _____ agcy _____ Object _____		TOTAL \$ 5351.80
	N/A ()	

Original Form Submitted with back up to County Judge's Office: Yes ()

CC with back up:

yes <input checked="" type="checkbox"/> Auditor	(281-341-3774)	yes <input checked="" type="checkbox"/> Comm. Pct. 1	(281-342-0587)
yes <input checked="" type="checkbox"/> Budget Officer	(281-344-3954)	yes <input checked="" type="checkbox"/> Comm. Pct. 2	(281-403-8009)
yes <input checked="" type="checkbox"/> County Attorney	(281-341-4557)	yes <input checked="" type="checkbox"/> Comm. Pct. 3	(281-242-9060)
yes <input checked="" type="checkbox"/> Purchasing Agent	(281-341-8642)	yes <input checked="" type="checkbox"/> Comm. Pct. 4	(281-980-9077)

- Instructions for submitting an Agenda Request:**
1. Completely fill out agenda form, incomplete forms will not be processed.
 2. Fax or inter-office copies of agenda form with all back up information by Wednesday at 2:00 p.m. to the departments listed above.
 3. All original back-up must be received in the County Judges Office by 2:00 p.m. on Wednesday.

RECOMMENDATION / ACTION REQUESTED:

**ACCIDENT DESCRIPTION DETAILS
COMMISSIONERS COURT AGENDA
OCTOBER 12, 1999**

1. **Sheriff/Parked - Not County's fault - Deputy's wife backing out of driveway- did not see parked County vehicle – struck front bumper of vehicle – Farmers Insurance has reimbursed for damages Auto Truck Appraisers \$ 78.00**
2. **Con2/Miller – Not County's fault – County van was struck by another driver At-fault party's carrier originally agreed for payment of rental of van while County's was being repaired- has now withdrawn payment authority Subrogation is pending with at-fault carrier - possible litigation to follow Premier Car Rental \$ 1638.00**
3. **R&B/Zwahr – Alleged County's fault – County driver clipped left rear of claimant's vehicle as claimant was making a right turn – Jacob Pawik \$1105.66 Auto Truck Appraisers \$ 99.00**
4. **Sheriff/Murphy – Not County's fault – Prisoner placed in back seat of patrol vehicle – prisoner began kicking the door and window causing damage to both Mike Hall Chevrolet \$130.00 Auto Truck Appraisers \$78.00**
5. **Sheriff/Jenkins – Alleged County's fault – County's driver was backing his vehicle his drivers door swung open and hit the parked claimant's vehicle Betty Ann Hughes \$ 275.13 Auto Truck Appraisers \$68.00**
6. **SocSer/Susca – Alleged County's fault – County driver was backing up and struck and parked vehicle belonging to Andrew Vilareal – Damage to right rear Andrew Vilareal \$602.01 Auto Truck Appraisers \$78.00**
7. **EmerManagement – Property damage due to vandalism – Damage to 14 windows Ray Glass Company \$ 1200.00**



Gallagher Bassett Services, Inc.

1800 W. Loop South, Suite 1080
Houston, TX 77027
713-961-1582
FAX: 713-622-4319

MEMO TO: SANDY KUCERA
FROM: CHRISTOPHER G. REID, SR
SUBJECT: Sheriff's Department
Unit # 16C
DATE: September 27, 1999
OUR NO : 011480-001029-AP-01
DOL: 9-11-99

THIS MEMO IS SUBMITTED TO BE PRESENTED AT THE NEXT COMMISSIONERS' COURT FOR APPROVAL OF AN APPRAISAL BILL FOR REPAIRS TO A COUNTY VEHICLE

FACTS: On September 11, 1999, Deputy Sheriff Mike Patton's assigned vehicle, Unit# 16C, was parked in his driveway at his residence. His wife, backing their personal vehicle, struck the County vehicle.

VEHICLE DAMAGED: Sheriff's Department Unit# 16C, a 1998 Chevrolet Camaro, VIN 2G1FP22GXWZ140438. Damage was to the right rear. The damage was appraised at \$606.80.

COMMENTS: Deputy Patten reported the accident to his insurance company, which has agreed to pay for the repairs. Thus, there will be no payment from the County for the damage to Unit 16C. Please advise if funds are authorized to pay for the appraisal in the amount of \$78.00. If authorized, the check should be issued as follows.

PAYEE: Auto Truck Appraisers, Inc.
2230 Elmgate
Houston, TX 77080

AMOUNT: \$78.00

AS PER ORIGINAL

TRUCK AUTO **A** APPRAISERS INC.

2220 ELMGATE 407-8898 HOUSTON, TEXAS 77080

INVOICE 31324-GB

CLAIM NO. _____

INS. CO. Halliburton Bassett ASSURED F. B. C. # 142
STREET ADDRESS 1800W Loop CLAIMANT _____
CITY Houston STATE TX ZIP 77027 DATE 9-17-99

ADJUSTER Chris

FEE.....	\$ <u>6500</u>
MILEAGE.....	<u>Richmond, TX.</u>	<u>1000</u>
PHOTOS.....		<u>NC</u>
MISC.....	<u>office apprais</u>	<u>300</u>
SALES TAX.....		<u>—</u>
DATE ASSIGNED <u>9-14</u>	DATE INSPECTED <u>9-17</u>	
	<u>Thank You</u>	
	TOTAL \$	<u>7800</u>

[Faint, illegible text at the bottom of the page]



Gallagher Bassett Services, Inc.

1800 W Loop South, Suite 1080
Houston, TX 77027
713-981-1582
FAX: 713-622-4319

MEMO TO: SANDY KUCERA
FROM: CHRISTOPHER G. REID, SR.
SUBJECT: Precinct 2 Constable- Unit# 36
DATE: October 2, 1999
OUR NO.: 011480-000967-AP-01
DOL: July 13, 1999

THIS MEMO IS SUBMITTED TO BE PRESENTED AT THE NEXT COMMISSIONERS' COURT FOR PAYMENT OF A RENTAL BILL INCURRED BY THE CONSTABLE'S OFFICE FOR THE TIME IT TOOK TO REPAIR THE COUNTY VEHICLE. THIS MEMORANDUM SUPPLEMENTS THE ORIGINAL REPORT OF THIS CLAIM DATED AUGUST 3, 1999

FACTS: As reported in the memorandum of August 3, 1999.

PROPERTY DAMAGED: Pct. 2 Constable Unit# 36. The Constable leased a van to use while the County vehicle was being repaired. The at-fault party's carrier originally agreed to pay the rental, but then withdrew payment authority. The replacement van was rented for a total of 40 days. The rental bill is for \$1801.80, which includes tax. Deducting the tax leaves a balance due of \$1638.00.

COMMENTS: Please advise if funds are authorized to pay for the net rental bill in the amount of \$1638.00. If approved, the check should be issued as follows.

PAYEE: Premier Car Rental
12614 SW Freeway, Suite G
Stafford, TX 77477

TIN: 36-4165277

AMOUNT: \$1638.00

36-4165277

AS PER ORIGINAL

12614 S.W. FREEWAY #G1
STAFFORD, TX 77477
(281) 277-0027

Quint



Premier
car rental

0403-027725

216351

Renter Last Name: Fort Bend County Constables Office		Rent Date: 7-15-99 From To: 7:00 AM		Del. Del. Date: 7-23-99 Date: 7-31-99	
Address: FM 2234		REPLACEMENT VEHICLE		ORIGINAL VEHICLE	
City: Mo City	State: TX	Zip: 77469	Unit No.:	4-4098	
Telephone: 281 403-8018	Acc. Rec. No.:		Ch. No.:	F55 CTM	
License No.:	Rate:	Est. Date:	Tr. Make:	99 GC Caravan	
Insurance Co.:	Telephone: 281 238-4740	Date of Birth:	License In:	TX 281 238-4740	
Contact Person:	Telephone: 329705806	Date of Birth:	Make/Model:	1997 238-4740	
Employer:	Fort Bend Constable 281 403-8018		CONDITION		
Company Paying for Rental:	Allstate - online		CONDITION		
Billing Address:			CONDITION		
City:	State:	Zip:	CONDITION		
Authorized By:	DOB:		CONDITION		
Name of Insured:	Date of Loss:	7-13-99	CONDITION		
Order No.:	State:		CONDITION		
4363107907-02	State		CONDITION		
Renter requests damage waiver (DW) at a rate of \$ per day and has read #4 and #6 on reverse side of this agreement.		Renter declines damage waiver (DW) and has read #4 and #5 on the reverse side of this agreement.			
Renter requests personal accident (PAD) at a rate of \$ per day and has read #6 on the reverse side of this agreement.		Renter declines personal accident insurance.			
Renter requests supplemental liability insurance (SLI) at a rate of \$ per day and has read #6 on the reverse side of this agreement.		Renter declines supplemental liability insurance.			
<p>A TEXAS PERSONAL AUTOMOBILE POLICY PROVIDES COVERAGE FOR THE LEGAL LIABILITIES OF THE POLICYHOLDER IN CONNECTION WITH THE LOSS OR DAMAGE TO A RENTED VEHICLE EXCEPT FOR DAMAGES CAUSED INTENTIONALLY; THEREFORE, IT MAY NOT BE NECESSARY FOR THE RENTER TO PURCHASE THE LOSS DAMAGE WAIVER. THE PURCHASE OF A LOSS DAMAGE WAIVER IS NOT MANDATORY. THE LOSS DAMAGE WAIVER IS NOT INSURANCE COVERAGE</p>					
<p>ADDITIONAL DRIVER - NONE PERMITTED WITHOUT PREMIER'S APPROVAL</p> <p>I request Premier's approval to allow:</p> <p>Name: G. Gilbert Blair Date of Birth: 06-26-54</p> <p>License No. 107970878 State TX Exp. Date 06-26-04</p> <p>who is under my control and direction to drive the rented vehicle for me in my behalf. I am responsible for their acts while they're driving, and for fulfilling terms and conditions of this agreement.</p> <p>Renter: [Signature] Premier's Authorization: [Signature]</p> <p>PERMISSION GRANTED FOR VEHICLE TO LEAVE THE STATE</p> <p>States: Texas only</p> <p>I have read and agreed to the terms on both sides of this rental agreement. As a courtesy, Premier Car Rental may bill a third party on my behalf. I understand that all charges incurred under the terms of this agreement remain my sole responsibility. I authorize my credit card to be processed periodically for any charges related to this rental and any signature below is considered to have been made on the applicable credit card vouchers. I authorize Premier Car Rental to deposit my check or cash left as security deposit on this rental.</p> <p>Renter: [Signature] Date: 7-23-99</p> <p>Vehicle is due back by 7-23-99 or at the end of 30 days or</p>					
Charges			RENTAL		
Basic Rate	40.00	39.99	1599	60	
Weekly Fee					
Weekend Rate					
Out Rate					
PA Rate					
SLI Rate					
Additional / Under Age Driver Surcharge					
Equipment					
Following Charge / Special Fee					
Early Del.					
TOTAL CHARGES					
Less Deposit					
Balance Due					
Less Cash Computer					
Net Due (or Refund)					
			RECEIVED		
			SEP 09 1999		
			GALLAGHER BASSETT		
			HOUSTON, TEXAS		
			TOTAL P.02		



Gallagher Bassett Services, Inc.

1800 W. Loop South, Suite 1080
Houston, TX 77027
713-681-1582
FAX: 713-622-4319

MEMO TO: SANDY KUCERA
FROM: CHRISTOPHER G REID, SR
SUBJECT: Road and Bridge Department
Driver- Dale Zwhar
DATE: October 2, 1999
OUR NO : 011480-001032-AD-01
DOL: August 23, 1999

THIS MEMO IS SUBMITTED TO BE PRESENTED AT THE NEXT COMMISSIONERS' COURT FOR APPROVAL OF PAYMENT OF REPAIRS TO A CLAIMANT'S VEHICLE INVOLVED IN AN ACCIDENT WITH A COUNTY VEHICLE, AND TO PAY FOR THE APPRAISER'S BILL.

FACTS: On August 23, 1999, County employee Dale Zwhar was driving a truck for Road and Bndge on Hwy 36 near the produce market. The claimant vehicle was ahead, slowing and making a night turn into the market. Mr Zwhar caught up with the claimant due to the difference in speed, and as he passed the claimant the right front fender and mirror of the County vehicle clipped the left rear of the claimant vehicle.

PROPERTY DAMAGED: 1991 Ford Explorer, VIN 1FMDU32X5MUC18771, owned by Jacob Pawlik. Damage was to the left rear. The claimant presented an estimate for \$1105.66. We had an appraisal done, which came to \$1575.61. It is recommended that we pay based upon the lower estimate.

COMMENTS: Please advise if funds are authorized to pay for the repairs in the amount of \$1105.66, and for the appraiser's bill in the amount of \$99.00. If authorized, the checks should be made payable as follows:

PAYEE: Jacob Pawlik
P.O. Box 322
East Bernard, TX 77435

AMOUNT: \$1105.66

PAYEE: Auto Truck Appraisers
2230 Elmgate
Houston, TX 77060

AMOUNT: \$99.00

CASTILLO'S BODY SHOP, INC.

Ignacio P. Castillo, Owner

817 Jennetta St. (Rear) - Rosenberg, Texas 77471

Phone 342-4134

AS PER ORIGINAL

3,15

NAME Jacob Pawlak		ADDRESS PO Box 322 EB, TX 77111			DATE 7 91
MAKE OF CAR FORD	YEAR 91	TYPE EXPLORE	LICENSE NO	MILEAGE	MOTOR NO
INSUR'D BY		ADJUSTER		INSPECTOR	

SYM	FRONT	PARTS HOURS	Net Parts & L	SYM	LEFT	PARTS HOURS	Net Parts & L	SYM	RIGHT	PARTS HOURS	Net Parts & L
	Bumper										
	Bumper Brkt.				Fender, Fron'				Fender, Front		
	Bumper Gd.				Fender Shield				Fender Shield		
	Frt. System				Fender Midg.				Fender Midg.		
									Headlamp		
	Cross Member				Headlamp Door				Headlamp Door		
	Stabilizer				Sealed Beam				Sealed Beam		
	Wheel				Cowl				Cowl		
	Hub Cap								Windshield		
	Hub & Drum				Door, Front				Door, Front		
	Knuckle										
	Knuckle Sup.				Door Hinge				Door Hinge		
	Lr Cont. Arm-Shaft				Door Glass				Door Glass		
					Vent Glass				Vent Glass		
	Up Cont Arm-Shaft				Door Midgs				Door Midg.		
					Door Handle				Door Handle		
	Tie Rod				Center Post				Center Post		
	Steering Gear				Door Rear				Door Rear		
	Steering Wheel				Door Glass				Door Glass		
	Horn Ring				Door Midg				Door Midg		
	Gravel Shield				Rocker Panel				Rocker Panel		
	Park Light Rt				Rocker Midg				Rocker Midg		
	Park Light Lf				Floor				Floor		
	Rad Grille				Qtr Panel				Qtr Panel		
	Grille Moldg				Qtr Midg				Qtr Midg.		
	Grille Support				Qtr Glass				Qtr Glass		
	Grill Embl				Fender, Rear				Fender, Rear		
	Name Plate				Fender Midg				Fender Midg		
	Horn				Fender Pad				Fender Pad		
					REAR				MISC		
	Baffle, Lower				Bumper				Inst Panel		
	Baffle, Upper				Bumper Brkt				Front Seat		
					Bumper Gd						
					Gravel Shield				Trim		
	Hood Top				Lower Panel				Headlining		
	Hood Hinge				Floor				Top		
	Hood Midg				Trunk Lid				Tire % Worn		
	Ornament								Paint		
	Rad. Sup.				Trunk Latch Ht						
	Rad. Core				Tail Light				Body Met		
	Anti Freeze				Tail Pipe						
	Rad Hoses										
	Fan Blade										
	Fan Shroud				Wheel						
	Water Pump										
	Motor Mts.				Axle						
	A-C Cond										
	A-C Service				Windshield						
					Frame						

1 front left 70.07.2

2 Tail gate 5.10
1 motor 71.16.3

30

1.3 36.00

1 Bumper Brkt - 37.15.3

AUTHORIZATION FOR REPAIRS

GROSS PARTS	719.21
Parts Less 10 %	
WRECKER	
NET PARTS	236.00
PAINT MATERIAL	120.00
SALES TAX	47.45
TOTAL LABOR	483.00
GRAND TOTAL	1,105.66

A—Align 1&2—New O—Overhaul S—Straighten R—Repair U—Used
 This estimate is based on lowest possible cost consistent with quality work, and as such, is guaranteed. Items not covered by this estimate or hidden will be additional.

Material Subject to Price Change

<h1 style="margin: 0;">TRUCK</h1> <h1 style="margin: 0;">AUTO APPRAISERS</h1> <p style="margin: 0;">2230 ELMGATE 467-2888 HOUSTON, TEXAS 77068</p>				DATE 9-10-99		REAR		NET		HRS.		PARTS			
				APPRaiser <i>[Signature]</i>		1 Bumper, Steel		2742						446	
				LOCATION 2719 BOLT H		5 Arms								18	
				LICENSE # VTD 37N		1 Valance								5218	
COMPANY <i>Balchou Bassett</i>				ASSIGNED BY <i>Don Massey</i>				SPEEDOMETER 37644		LOWER PANEL					
FIRST PARTY				THIRD PARTY <i>Jacob Pawlak</i>				FLOOR							
YEAR 91		MAKE Ford Explorer XL		MODEL 1FMDU33X5MUC187M		S		Quarter R							
A - Align		1-2 New		OH - Overhaul		S - Straighten		R - Repair		Moulding					
FRONT				FRONT				FRONT				FRONT			
NET				NET				NET				NET			
HRS.				HRS.				HRS.				HRS.			
PARTS				PARTS				PARTS				PARTS			
Bumper				Horn				5 T-Plate							
Arms				Headlamp				Trunk Lid				50			
Valance				Door				1 Moulding Lwr				8398			
Gravel Guard				Seal Beam				2 N Plates				4 2753			
Wheel				Battery				1 Tail Light				4 9087			
Hub & Disc				Park'g Lamp				Tail Pipe							
Steer's Wheel				Hood				Gas Tank							
Horn Ring				Hood Mould'g				Door							
Up Cont. Arm Shaft				Hood Lock Plt				Glass Tint Clear							
Lr Cont. Arm Shaft				Hood Hinges				Door Handle							
Knuckle				Ornament				Moulding							
Frt. System				Ext				Lock							
Tire				Fender Right				Roof Tint (see to head)				15			
Motor Supp't				Moulding				Door							
				Name Plate				Glass Tint Clear							
				Skirt				Door Handle							
Grill Panel				Aerial				Moulding							
Grill				Ext				Lock							
Moulding				Fender Left				Seat				- 3500			
				Moulding				EPA				500			
				Name Plate				Ceat's Post							
Extension				Skirt				Rocker Panel							
Ext Mould'g				Windsh'ld Clear				Moulding							
				Moulding				Painting				109			
Air Cond.				Frame				GROSS TOTAL				532 225 25878			
Condenser								LABOR 22.5 HRS.				8320 720 00			
Receiver				Roof				PARTS							
				Cowt				LESS				25878			
Radiat'r Core								NET				53200			
Core Supp't								WRECKER							
Fan & Clutch								TAX				6483			
Water Pump								TOTAL REPAIRS				15725			
Shroud								KIND OF LOSS:				<input checked="" type="checkbox"/> Collision <input type="checkbox"/> Vandalism <input type="checkbox"/> Fire <input type="checkbox"/> Theft <input type="checkbox"/> Water <input type="checkbox"/> Other <input type="checkbox"/> Other Remarks (Back)			
REPAIRER <i>OWNER'S CHOICE</i>				BY											
EQUIPMENT				<input type="checkbox"/> AM Radio <input type="checkbox"/> AM-FM Radio <input type="checkbox"/> AM-FM Stereo <input type="checkbox"/> Tape Deck <input type="checkbox"/> Heater <input type="checkbox"/> P Brakes <input type="checkbox"/> P Steer <input type="checkbox"/> Air											
CONDITION				<input type="checkbox"/> Very Good <input checked="" type="checkbox"/> Good <input type="checkbox"/> Fair <input type="checkbox"/> Poor <input type="checkbox"/> Very Poor											
TIRES				LF <input type="checkbox"/> RF <input type="checkbox"/> RR <input type="checkbox"/> LR <input type="checkbox"/> SPARE											
Transmission				<input type="checkbox"/> Other Equipment											

THIS IS NOT AN AUTHORIZATION TO REPAIR.

**Gallagher Bassett Services, Inc.**

1800 W. Loop South, Suite 1080
Houston, TX 77027
713-661-1582
FAX 713-622-4319

MEMO TO: SANDY KUCERA
FROM: CHRISTOPHER G. REID, SR
SUBJECT: Sheriff's Department, Unit# 15B
DATE: October 2, 1999
OUR NO.: 011480-001033-AP-01
DOL: August 20, 1999

THIS MEMO IS SUBMITTED TO BE PRESENTED AT THE NEXT COMMISSIONERS' COURT FOR APPROVAL OF PAYMENT OF REPAIRS TO A COUNTY VEHICLE, AND TO PAY FOR THE APPRAISER'S BILL.

FACTS: On August 20, 1999, Deputy Chris Murphy had placed a prisoner in the back of his patrol vehicle. The prisoner began kicking the door and window, damaging same.

PROPERTY DAMAGED: 1997 Ford Crown Victoria, Unit# 15B, VIN 2FALP71W3VX148971
Damage was to the right rear door window frame and mechanism. The damaged was appraised at \$735.20. Bids were let, and only one was received, from Mike Hall Chevrolet in the amount of \$130.00. This bid is less than the appraisal, and should be accepted.

COMMENTS: Please advise if funds are authorized to pay for the repairs in the amount of \$130.00, and for the appraiser's bill in the amount of \$78.00. If authorized, the checks should be made payable as follows

PAYEE: Mike Hall Chevrolet
8100 S Highway 6
Houston, TX 77083

AMOUNT: \$130.00

PAYEE: Auto Truck Appraisers
2230 Elmgate
Houston, TX 77080

AMOUNT: \$78.00

AS PER ORIGINAL

TRUCK AUTO APPRAISERS								PEAR	NET	MRS.	PARTS								
2290 ELMGATE 467-8888 HOUSTON, TEXAS 77080				DATE 8/27/99				Bumper											
				APPRAISER <i>Alonso</i>				Arms											
				LOCATION <i>Richmond VA</i>				Valance											
COMPANY <i>Gallagher Bassett</i>		ASSIGNED BY <i>Barbara</i>		LICENCE # <i>716 303</i>				Lower Panel											
FIRST PARTY <i>F B C Shred</i>		THIRD PARTY <i>UNIT # 15B</i>		SPEEDOMETER <i>115000</i>				Floor											
YEAR <i>97</i>	MAKE <i>Ford</i>	MODEL <i>Contour</i>	VEHICLE SERIAL NO <i>2FALP71U13VX148971</i>																
A - Align				1-2 - New				OH - Overhaul				S - Straighten				R - Repair			
FRONT	NET	MRS.	PARTS	FRONT	NET	MRS.	PARTS												
Bumper				Horn															
Arms				Headlamp															
Valance				Door															
Gravel Guard				Seal Beam															
				Battery															
Wheel				Park'g Lamp															
Hub Cap Disc.																			
Steer's Wheel				Hood															
Horn Ring				Hood Mould'g															
Up Cont. Arm Shat				Hood Lock Pjt															
Lc. Cont. Arm Shat				Hood Hinges															
Knuckle				Ornament															
Frs System																			
Tire				Ext															
Motor Supp't				Fender Right															
				Moulding															
				Name Plate															
				Skirt															
Grill Panel				Aerial															
Grill				Ext															
Moulding				Fender Left															
				Moulding															
				Name Plate															
Extension				Skirt															
Ext. Mould'g																			
				Windsh'd Clear															
				Moulding															
Air Cond.																			
Condenser				Frame															
Receiver																			
				Roof															
Radiat'r Core																			
Core Supp't				Cowl															
Fan & Clutch																			
Water Pump																			
Shroud																			
REPAIRED BY <i>Alonso</i>											GROSS TOTAL								
EQUIPMENT	<input checked="" type="checkbox"/> AM Radio	<input type="checkbox"/> AM-FM Radio	<input type="checkbox"/> AM-FM Stereo	<input type="checkbox"/> Tape Deck	<input checked="" type="checkbox"/> Heater							LABOR		50	MRS.	0.30	\$	15000	
	<input type="checkbox"/> P. Brakes	<input type="checkbox"/> P. Steer	<input type="checkbox"/> Air							PARTS									
CONDITION	<input type="checkbox"/> Very Good	<input checked="" type="checkbox"/> Good	<input type="checkbox"/> Fair	<input type="checkbox"/> Poor	<input type="checkbox"/> Very Poor							LESS							
TIRES	LF	RP	RR	LR	SPARE							NET							
Transmission	<i>Over</i>	Motor	<i>18</i>	Other Equipment							WRECKER								
											TAX								
											TOTAL REPAIRS								
											KIND OF LOSS		<input type="checkbox"/> Collision	<input checked="" type="checkbox"/> Vandalism	<input type="checkbox"/> Fire				
													<input type="checkbox"/> Theft	<input type="checkbox"/> Water	<input type="checkbox"/> Other	Other Remarks (Each)			

THIS IS NOT AN AUTHORIZATION TO REPAIR.

AS PER ORIGINAL

AUTO TRUCK APPRAISERS INC.

2220 ELMGATE 487-8998 HOUSTON, TEXAS 77080

INVOICE 31321-GB

CLAIM NO. _____

INS. CO. Bullseye Bennett ASSURED FBI Shady
 STREET ADDRESS 1500 W Loop CLAIMANT #155
 CITY Houston STATE TX ZIP _____ DATE 8-27-99

ADJUSTER Chris Reed

FEE..... \$ 6500
 MILEAGE..... 1000
 PHOTOS..... pc
 MISC..... 3000
 SALES TAX..... _____
 DATE ASSIGNED 8/24 DATE INSPECTED 8/27
 TOTAL \$ 7800

Thank You

AS PER ORIGINAL

08/31/1999 at 07:12 AM
10827

Job Number:

HALL CHEVROLET, INC.

License #:

AUTO NATION USA / THE POWER OF THE NETWORK
8100 SOUTH HWY 6
HOUSTON, TX 77083
(281)983-9820 Fax: (281)983-9875

PRELIMINARY ESTIMATE

Written by:
Adjuster:

Insured: FORT BEND COUNTY MA
Owner: FORT BEND COUNTY MA
Address: 730 LEGION
RICHMOND, TX 77469
Business: (281)341-4790
Fax: (281)238-9650

Claim # **158**
Policy #
 deductible:
Date of Loss:
Type of Loss:
Point of Impact:

Inspect
Location:

Insurance
Company:

Days to Repair

97 FORD CROWN VICTORIA POLICE 8-4.6L-VT 4D SED WHITE Int:

VIN: 2FALP71W3VX148971 Lic:

Prod Date:

Odometer: 115002

Air Conditioning	Rear Defogger	Tilt Wheel
Intermittent Wipers	Tinted Glass	Dual Mirrors
Clear Coat Paint	Power Steering	Power Brakes
Power Windows	Power Mirrors	Driver Airbag
Passenger Airbag	4 Wheel Disc Brakes	Cloth Seats
Split Bench Seats		

NO.	QTY	DESCRIPTION	EXT. PRICE	LABOR	PAINT
1		REAR DOOR			
2*	Rpr	RT Glass panel rna & stationary			4.0
3*	R&I	RT Door glass BRKS			1.0

1

RECEIVED
SEP 22 1999
GALLAGHER BASSETT
HOUSTON TEXAS

08/31/1999 at 07:12 AM
 10627

Job Number:

PRELIMINARY ESTIMATE

97 FORD CROWN VICTORIA POLICE 8-4.6L-FI 6D SED WHITE Int:

NO.	OP.	DESCRIPTION	QTY	EXT.	PRICE	LABOR	PRINT
Subtotals ==>				0.00		5.0	0.0
		Parts					0.00
		Body Labor	5.0 hrs @	\$ 26.00/hr			130.00
SUBTOTAL							\$ 130.00
GRAND TOTAL							\$ 130.00
ADJUSTMENTS:							
		Deductible					0.00
CUSTOMER PAY							\$ 0.00
INSURANCE PAY							\$ 130.00

Estimate based on MOTOR CRASH ESTIMATING GUIDE. Non-asterisk(*) items are derived from the Guide DE2JAS2. Database Date 7/1999. Double asterisk(**) items indicate parts supplied by a supplier other than the original equipment manufacturer. Pound sign (\$) items indicate manual entries. CPA items have been certified for fit and finish by the Certified A&S Parts Association. NACS Part Numbers, Prices and Labor Times are provided from National Auto Glass Specifications, Inc.

Pathways - a product of CCC Information Services Inc.

RECEIVED
 [SEP 22 1999
 GALLAGHER BASSETT
 HOUSTON TEXAS

**Gallagher Bassett Services, Inc.**

1800 W. Loop South, Suite 1080
Houston, TX 77027
713-861-1582
FAX 713-622-4319

MEMO TO SANDY KUCERA
FROM: CHRISTOPHER G. REID, SR.
SUBJECT Sheriff's Department
Deputy Bill Jenkins
DATE. October 2, 1999
OUR NO . 011480-001027-AD-01
DOL: August 20, 1999

THIS MEMO IS SUBMITTED TO BE PRESENTED AT THE NEXT COMMISSIONERS' COURT FOR APPROVAL OF PAYMENT OF REPAIRS TO A CLAIMANT VEHICLE INVOLVED IN AN ACCIDENT WITH A COUNTY VEHICLE, AND TO PAY FOR THE APPRAISER'S BILL.

FACTS: On September 21, 1999, Deputy Jenkins was at the scene of a motor vehicle accident in his assigned County vehicle. While backing his vehicle, his driver door, which was unlatched, swung open and hit the parked claimant vehicle.

PROPERTY DAMAGED: 1999 Ford Escort LX, VIN 1FAPP10P5XW130488. Damage was to the rear bumper cover on the left side. The damaged was appraised at \$275.13.

COMMENTS: Please advise if funds are authorized to pay for the repairs in the amount of \$275.13, and for the appraiser's bill in the amount of \$68.00. If authorized, the checks should be made payable as follows:

PAYEE: Betty Anne Hughes
5930 Indigo Street
Houston, TX 77074

AMOUNT: \$275.13

PAYEE: Auto Truck Appraisers
2230 Elmgate
Houston, TX 77080

AMOUNT: \$68.00

011480-001027-AD-01

AS PER ORIGINAL

TRUCK AUTO APPRAISERS		DATE	9-29-99	REAR	Bumper	NET	20	PARTS	
		APPRaiser	Blank	Arms					
2230 ELMGATE 467-8888 HOUSTON, TEXAS 77080		LOCATION	5730 Indigo	Valance					
COMPANY	ASSIGNED BY	LICENCE	C. 109 SIZ	Lower Panel					
FIRST PARTY	THIRD PARTY	SPEEDOMETER	11719	Floor					
YEAR	MAKE	MODEL	4671FAFPDPSXW130488	Quarter R.					
09	Ford	Escort LX		Quarter L.					
A - Align 1-3 - New OH - Overhaul S - Straighten R - Repair				Quarter Ext					
				Moulding					

FRONT	NET	MRS.	PARTS	FRONT	NET	MRS.	PARTS
Bumper				Horn			
Arms				Headlamp			
Valance				Door			Trunk Lid
Gravel Guard				Seal Beam			Moulding
Wheel				Battery			Tail Light
Hub Cap				Park'g Lamp			Tail Pipe
Steer's Wheel				Hood			Gas Tank
Horn Ring				Hood Mould'g			Door
Up Cent. Arm-Bolt				Hood Lock Pll			Glass Tin
Lr Cent. Arm-Bolt				Hood Hinges			Clear
Knuckle				Ornament			Door Handle
Prt. System				Ext			Moulding
Tire				Fender Right			Lock
Motor Supp't				Moulding			Door
				Name Plate			Glass Tin
				Skirt			Clear
Grill Panel				Aerial			Door Handle
Grill				Ext			Moulding
Moulding				Fender Left			Lock
Extension				Moulding			✓ Flt
Ext Mould'g				Name Plate			✓ Seal
				Skirt			500
				Windsh'd Chr			Cent's Post
				Moulding			Recker Panel
Air Cond				Frame			Moulding
Condenser				Roof			✓ CIC
Receiver				Cowl			Painting 1000 36
							500
Radiat'r Core							GROSS TOTAL
Core Supp'rt							89.00 56
Fan & Clutch							LABOR 5.6 hrs. @ 35.00 = 197.80
Water Pump							PARTS LESS
Shroud							NET 89.00

REPAIRER owners choice BY _____

EQUIPMENT AM Radio AM-FM Radio AM-FM Stereo Tape Deck Recker

Brakes P. Steer Air

CONDITION Very Good Good Fair Poor Very Poor

TIRES LF _____ RR _____ RR _____ LR _____ SPARE _____

Transmission _____ Motor _____ Other Equipment _____

GROSS TOTAL	89.00	56
LABOR	5.6 hrs. @ 35.00	197.80
PARTS LESS		
NET		89.00
WRECKER		
TAX		6.93
TOTAL REPAIRS		225.13

KIND OF LOSS Collision Vandalism Fire

Theft Wind Other Other Remarks (Back)

PRESENT THIS ESTIMATE TO THE REPAIR SHOP

THIS IS NOT AN AUTHORIZATION TO REPAIR

AS PER ORIGINAL

AUTO TRUCK APPRAISERS INC.

2230 ELMGATE (713) 467-8698 HOUSTON TEXAS 77060

INVOICE 31325-6B

CLAIM NO 01480-001037-AD-01

INS. CO. Shell Capital Energy ASSURED 0000
 STREET ADDRESS 1100 W. Loop CLAIMANT Scott A. Hughes
 CITY Houston STATE TX ZIP 77027 DATE 9-29-99

ADJUSTER Chris Todd

FEE..... \$ 6500
 MILEAGE..... NC
 PHOTOS..... (2) NC
 MISC..... off road charge 300
 SALES TAX..... _____
 DATE ASSIGNED 9-27 DATE INSPECTED 9-29
 TOTAL \$ 6800

Thank You

**Gallagher Bassett Services, Inc.**

1800 W Loop South, Suite 1080
Houston, TX 77027
713-661-1562
FAX 713-622-4319

MEMO TO: SANDY KUCERA
FROM: CHRISTOPHER G REID, SR.
SUBJECT: Social Services, Unit# SS6
DATE: October 2, 1999
OUR NO 011480-001000-AD-01 (Claimant vehicle)
011480-001000-AP-01 (County vehicle)
DOL: August 16, 1999

THIS MEMO IS SUBMITTED TO BE PRESENTED AT THE NEXT COMMISSIONERS' COURT FOR APPROVAL OF PAYMENT OF REPAIRS TO A CLAIMANT VEHICLE INVOLVED IN AN ACCIDENT WITH A COUNTY VEHICLE, AND THE APPRAISAL BILL FOR THE COUNTY VEHICLE.

FACTS: On August 16, 1999, Seto Susca of Social Services was backing up a County van when it struck a parked vehicle owned by the claimant.

PROPERTY DAMAGED: 1997 Ford Club Wagon, Social Services Unit# SS6, VIN 1FBHE31L0UHA87040. Damage was to the right rear wheel well, and was appraised at \$445.00. The claimant vehicle is a 1999 Plymouth Grand Voyager, VIN 2P4GP44G6XR184171, owned by Andrew Villareal. Damage was to the right rear. Several estimates were submitted, with the lowest being \$602.01.

COMMENTS: Please advise if funds are authorized to pay for the repairs to the claimant vehicle in the amount of \$602.01, and for the appraiser's bill in the amount of \$78.00. If authorized, the checks should be made payable as follows:

PAYEE: Andrew Villareal
Box 88S
E. Bernard, TX 77435

AMOUNT: \$602.01

PAYEE: Auto Truck Appraisers
2230 Elmgate
Houston, TX 77080

AMOUNT: \$78.00

AUTO APPRAISERS INC.

2230 ELMGATE 457-8988 HOUSTON, TEXAS 77090

CLAIM NO. _____

INVOICE 31322-GB

INS. CO. Hallinger & Sonnet ASSURED FBI-Security Services

STREET ADDRESS 1890W Loop CLAIMANT unit # 556

CITY Houston STATE TX ZIP 77027 DATE 8-31-99

ADJUSTER Walt Reid

FEE..... Appraised 4 photos \$ 6500

MILEAGE... Richmond, TX 1000

PHOTOS PC nc

MISC..... 3 ea

SALES TAX.....

DATE ASSIGNED 8-26 DATE INSPECTED 8-31

TOTAL \$ 7800

Thank You

08/18/1999 at 01 27 PM
29309

Job Number.

PEKAR'S BODYSHOP, INC
WE TAKE THE DENTS OUT OF ACCIDENTS
2720 N RICHMOND RD.
WHARTON, TX
(409)532-5805 Fax: (409)532-3080

PRELIMINARY ESTIMATE

Written by MIKE SNYDER #
Adjuster

Insured: ANDREW VILLARREAL
Owner: ANDREW VILLARREAL
Address 1226 HILLTOP RD
BOX 88S`
E BERNARD, TX 77435
Day: (409)532-8549

Claim #
Policy #
Deductible.
Date of Loss
Type of Loss
Point of Impact 5 Right Rear

Inspect
Location.

Insurance
Company:

Days to Repair

RECEIVED
AUG 18 1999

99 PLYM GRAND VOYAGER 4X2 SE 6-3 3L-FI 3D VAN Int
VIN 2P4GP44G6XR184171 Lic D30-JJV TX Prod Date.

Colmeton LAINGER BASSETT
HOUSTON TEXAS

08/18/1999 at 01:27 PM
29309

Job Number

PRELIMINARY ESTIMATE

99 PLYM GRAND VOYAGER 4X2 SE 6-3 3L-FI 3D VAN Int:

Air Conditioning	Rear Defogger	Tilt Wheel
Cruise Control	Intermittent Wipers	Body Side Moldings
Dual Mirrors	Privacy Glass	Clear Coat Paint
Metallic Paint	Stone Guard	Power Steering
Power Brakes	Power Windows	Power Locks
Power Mirrors	AM Radio	FM Radio
Stereo	Cassette	Search/Seek
Anti-Lock Brakes (4)	Driver Airbag	Passenger Airbag
Clotn Seats	Bucket Scats	7 Passenger Option
Automatic Transmission	Overdrive	

NO	OP	DESCRIPTION	QTY	EXT	PRICE	LABOR	PAINT
1		SIDE PANEL					
2*	Rpr	RT Side panel 113" WB				6.3	2.7
3		Add for Clear Coat					1.1
4		Add for Stone Guard					0.5
5		REAR BUMPER					
6	R&I	R&I bumper assy				0.8	
7		REAR LAMPS					
8	Repl	RT Combo lamp	1		78.00	0.3	
9#	Refn	BLEND PAINT					
10#	Subl	HAZ WASTE REMOVAL	1		5.00 X		

RECEIVED
AUG 18 1998

Subtotals ==> 83.00 7.1 GALLACHER BASSETT HOUSTON TEXAS

Parts		78.00
Body Labor	7.1 hrs @ \$ 30.00/hr	213.00
Paint Labor	5.8 hrs @ \$ 30.00/hr	174.00
Paint Supplies	5.8 hrs @ \$ 20.00/hr	116.00
Sublet/Misc.		5.00
SUBTOTAL		\$ 586.00

08/18/1999 at 01.27 PM
29309

Job Number.

PRELIMINARY ESTIMATE

99 PLYM GRAND VOYAGER 4X2 SE 6-3.3L-FI 3D VAN Int.

Sales Tax	\$ 194.00 @ 8 2500%	16 01

GRAND TOTAL		\$ 602 01
ADJUSTMENTS		
Deductible		0.00

CUSTOMER PAY		\$ 0 00
INSURANCE PAY		\$ 602 01

Estimate based on MOTOR CRASH ESTIMATING GUIDE Non-asterisk(*) items are derived from the Guide DRI7E96. Database Date 5/1999. Double asterisk(**) items indicate parts supplied by a supplier other than the original equipment manufacturer. Pound sign (\$) items indicate manual entries. CAPA items have been certified for fit and finish by the Certified Auto Parts Association. NAGS Part Numbers, Prices and Labor Times are provided from National Auto Glass Specifications, Inc.

Pathways - A product of CCC Information Services Inc.

RECEIVED
AUG 1 6
CALLAGHER BASSETT
HOUSTON TEXAS



Gallagher Bassett Services, Inc.

1800 W. Loop South, Suite 1080
Houston, TX 77027
713-981-1582
FAX: 713-622-4319

MEMO TO SANDY KUCERA
FROM: CHRISTOPHER G. REID, SR
SUBJECT: Emergency Management Operations Building
DATE: October 2, 1999
OUR NO.. 011480-001030-RB-01
DOL: May 8, 1999

THIS MEMO IS SUBMITTED TO BE PRESENTED AT THE NEXT COMMISSIONERS' COURT FOR APPROVAL OF A BILL FOR REPLACEMENT OF BROKEN WINDOWS AT THE EMERGENCY MANAGEMENT OPERATIONS BUILDING

FACTS: Between May 8, 1999, and May 11, 1999, unknown vandals threw rocks at the windows of the Emergency Management Operations building at 307 Fort Street, breaking and cracking multiple windows.

PROPERTY DAMAGED: 14 windows at 307 Fort Street. Rays Glass gave a quote of \$1,200.00 to replace all 14 windows, 28" x 48" x 1/8" each.

COMMENTS: Please advise if funds are authorized to pay for the repairs in the amount of \$1200.00. If authorized, the check should be issued as follows:

PAYEE: Ray Glass Company
P.O. Box 1065
Rosenberg, TX 77471

AMOUNT: \$1200 00

Established 1949

RAY GLASS COMPANY, INC.

AS PER ORIGINAL

Office Telephone: 232-6416
Houston Line: 342-2042

Bob Ray

P O. Box 1065
2719 Ave H
Rosenberg, Texas 77471-1065

QUOTATION

AUGUST 26, 1999

FORT BEND CO. EMERGENCY MANAGEMENT
307 FORT
RICHMOND, TX. 77469

REPLACE 14 BROKEN WINDOWS IN BUILDING.
APPROX. SIZE 28" x 48" CLEAR 1/8" GLASS

TOTAL MATERIAL AND LABOR.....\$1,200

RECEIVED
FORT BEND COUNTY
RISK MANAGEMENT
99 AUG 26 AM 11:18

RECEIVED

AUG 27 1999

GALLAGHER BASSETT
HOUSTON, TEXAS

**FORT BEND COUNTY
 COMMISSIONERS COURT AGENDA REQUEST FORM
 RETURN TO: AGENDA COORD.-COUNTY JUDGE'S OFFICE**

DATE SUBMITTED: 10/4/99
 COMMISSIONERS COURT AGENDA FOR: 10/12/99

DEPT. SUBMITTED BY: County Attorney for Tax Office
 DEPT. PHONE NO. 281-341-4556

11 A-6

SUMMARY OF ITEM:

Discuss and consider taking action on Resale of Property taken under Cause No. 71,457; Fort Bend ISD vs. Edward Austin;

Discuss and consider taking action on Resale of Property taken under Cause No. 80,176; Lamar CISD vs. ~~Linda~~ ^{Louisa} Munoz, et. al

RENEWAL CONTRACT/AGREEMENT: Yes () No (X)

LIST SUPPORTING DOCUMENTS ATTACHED: yes
 (Back-up documentation must be attached for consideration)

FINANCIAL SUMMARY:

BUDGETED ITEM: Yes() No() N/A()	ANNUALIZED DOLLARS One Time ()	COMMENTS.
Funding Source: Fund _____ Agcy. _____ Object _____	Recurring ()	
	N/A ()	

Original form submitted with back up to County Judge's Office: Yes: (x)

CC with back up:

Auditor	(281-341-3774)	Comm. Pct. 1	(281-344-0587)
Budget Officer	(281-344-3954)	Comm. Pct. 2	(281-403-8009)
County Attorney	(281-341-4557)	Comm. Pct. 3	(281-242-9060)
Purchasing Agent	(281-341-8642)	Comm. Pct. 4	(281-980-9077) yes
Marsha Gaines, Tax Assessor-Collector			

Instructions for submitting an Agenda Request:

- 1 Completely fill out agenda form, incomplete forms will not be processed
- 2 Fax or inter-office copies of agenda form with all back-up information by Wednesday at 2 00 p m to the departments listed above
- 3 All original back-up must be received in the County Judge's Office by 2 00 p m. on Wednesday

10-20-99

Both Original letters + Quilcain deed sent to Karen Stell at the Tax Office.



TAX ASSESSOR/COLLECTOR

FORT BEND COUNTY, TEXAS

MARSHA P GAINES

(281) 341-3710
Fax (281) 341-9267

DATE: September 29, 1999

TO: Mr Bud Childers
Fort Bend County Attorney

FROM: Karen Stell *Karen Stell*
Assistant Division Supervisor, Taxes

RE: Resale of Property taken under Cause# 71,457
Fort Bend ISD vs. Edward Austin
1150-00-002-4900-907

Attached is copy of letter received from Linebarger, Heard, Goggan, Blair, Graham, Pena & Sampson LLP, delinquent attorneys for Fort Bend Independent School District, requesting resale of property taken under Cause 71,457.

Clearly outlined is the breakdown for each taxing entity named in the suit.

Linebarger, Heard, Goggan, Blair, Graham, Pena & Sampson LLP request this be placed on the Commissioners Court Agenda so they may approve or disapprove this sale. The original documents are attached. Please have the appropriate party sign, if approved and return to my attention.

Please review and place on the agenda. Contact me at 341-3723 if you have any questions.

cc Wanda James
Linebarger, Heard, Goggin, Blair, Graham, Pena & Sampson LLP

LHGBGPS-092999-kes

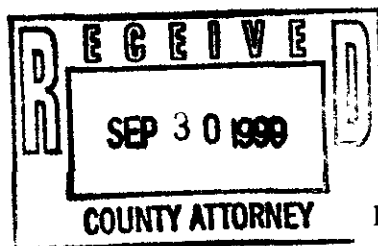

P O Box 399 • Richmond, Texas 77406-0399

Calame Linebarger Graham & Pena, LLP

ATTORNEYS-AT-LAW
1021 MAIN STREET, SUITE 1500
HOUSTON, TEXAS 77002
(713) 844-3400
FAX (713) 844-3501

September 10, 1999

SEP 14 1999

Ms Karen Stell
Assistant Division Supervisor
Property Tax, Fort Bend County
P O Box 399
Richmond, Texas 77406-0399

Re: Suit No. 71-457; Fort Bend Independent School District vs. Edward Austin
Judgment Date: April 10, 1991
Judgment Years: 1975-1990; Post Judgment Years: 1991
Struck Off Date: July 2, 1991
Account No: 1150-00-002-4900-907; 635 Coen Rd.

Dear Karen:

Mr. Jimmy N. Wilton has made an offer to purchase the above referenced property for the amount of \$5,000.00

The proceeds from the sale will be disbursed as follows:

Court Cost	\$ 239.00		
Realtor's Commission	\$ 300.00		
Post Judgment Taxes	\$ 759.18	Fort Bend ISD	(1991 Taxes)
Post Judgment Taxes	\$ 171.80	Fort Bend County	(1991 Taxes)
Fort Bend ISD	\$2,753.42		=78%
Fort Bend County	\$ 776.60		=22%
	\$5,000.00		

Enclosed a copy of the Judgment, Constable's Deed and Sheriff's Return for your review. Please place this item on the next available agenda.

If you have any questions on this matter, please do not hesitate to call me.

Sincerely,

Michael J. Siwierka
Attorney At Law

Approved, Agreed To and Accepted
Fort Bend County

By 
James Adolphus
County Judge

Date October 12, 1999

NO 71,457

FORT BEND INDEPENDENT	{	IN THE DISTRICT COURT OF
SCHOOL DISTRICT,	{	
PLAINTIFF	{	
	{	
VS	{	FORT BEND COUNTY, TEXAS
EDWARD AUSTIN	{	
DEFENDANT	{	
	{	
VS.	{	
STATE OF TEXAS,	{	
COUNTY OF FORT BEND	{	
INTERVENOR	{	240TH JUDICIAL DISTRICT

DEFAULT JUDGMENT

BE IT REMEMBERED that on this 10 day of April, 1991, being the appearance date of Defendant(s), EDWARD AUSTIN, and the Court regularly in session and term, time and place, wherein the above entitled and numbered cause was commenced, and the Judge in open court regularly called said cause in order on the docket, and came Plaintiff, FORT BEND INDEPENDENT SCHOOL DISTRICT by its attorney, and also came Intervenor(s), STATE OF TEXAS, COUNTY OF FORT BEND by their respective counsel, and Defendant(s) having been duly served with citation herein ~~has wholly made default and citation having been~~ ^{appeared, but failed to file any} ~~written answer~~ ^{on file with the District Clerk for more than ten (10) days excluding the day of} ~~filed~~. A jury having been waived, and all matters of fact and law herein having been submitted, the Court, after considering the pleadings, arguments of counsel, and evidence presented at the time of trial finds that this is a suit brought for the collection of delinquent taxes and that all legal prerequisites commanded by law on the part of all officials for Plaintiff and Intervenor(s) have been properly satisfied and completed, and that the Defendant(s) is indebted to the Plaintiff and Intervenor(s) for such delinquent taxes, penalty and interest as proven at the time of trial, and that the Plaintiff and Intervenor(s) should have judgment and a

Jones/Roseman & Wiseman
 A Law Firm of
 Professional Corporations
 12603 Southwest Freeway
 Suite 360
 Stafford, Texas
 77477
 Telephone 974-1422
 Area Code 713

foreclosure of their tax lien on the property hereinafter described, and therefore

BE IT ORDERED, ADJUDGED AND DECREED by this Court that Plaintiff, FORT BEND INDEPENDENT SCHOOL DISTRICT, have and recover of and from Defendant(s), the total sum of \$9,080.34 with the amount due on each property being separately stated per year on Exhibit "A" attached hereto and incorporated herein for all purposes, together with interest thereon at the rate of twelve (12%) percent per annum from the date of this judgment until fully paid, and all costs of court incurred

BE IT ORDERED, ADJUDGED AND DECREED by this Court that Intervenor, STATE OF TEXAS, COUNTY OF FORT BEND, have and recover of and from Defendant(s), the total sum of \$2,559.56 with the amount due on each property being separately stated per year on Exhibit "A" attached hereto and incorporated herein for all purposes, together with interest thereon at the rate of twelve (12%) percent per annum from the date of this judgment until fully paid, and all costs of court incurred

IT IS FURTHER ORDERED that Plaintiff and Intervenor(s) shall have foreclosure of their tax liens effective as of the date of this Judgment, and the following described property shall be sold in satisfaction of the amount of this Judgment.

PROPERTY DESCRIPTION CONTAINED IN
EXHIBIT "A" AND THE SAME IS INCORPORATED
HEREIN FOR ALL PURPOSES

IT IS FURTHER ORDERED that the adjudged value of each property herein being foreclosed upon is the value as noted in Exhibit "A" attached hereto and incorporated herein for all purposes

Jones/Roseman & Wiseman
A Law Firm of
Professional Corporations
.2603 Southwest Freeway
Suite 360
Stafford, Texas
77477
Telephone 979-1212
Area Code 713

IT IS FURTHER ORDERED that Plaintiff and Intervenor(s) shall recover, for the current tax year, an amount equal to the proration of last year's tax up to and including the date of this judgment

IT IS FURTHER ORDERED that an Order of Sale shall issue to any Sheriff or Constable within the State of Texas to seize and sell the described property the same as under execution and satisfaction of this judgment. A Writ of Possession shall issue to the purchaser at such sale or his assigns.

IT IS FURTHER ORDERED that if any surplus remains after the payment of the sum adjudged to be due it shall be paid to the Clerk of this Court and held for a period of seven (7) years from the date of this sale, subject to further orders of this Court

IT IS FURTHER ORDERED that all costs of Court incurred herein shall be adjudged against the Defendant(s) for which let execution issue

SIGNED this 10 day of April, 1991.

[Handwritten Signature]
JUDGE PRESIDING

APPROVED AS TO FORM

JONES/ROSEMAN & WISEMAN

HEARD, GOGGAN, BLAIR & WILLIAMS

BY: *[Handwritten Signature]*

BY: *[Handwritten Signature]*

TERRY G WISEMAN
SBOT #21816500
5847 SAN FELIPE, #1550
HOUSTON, TEXAS 77057
(713) 974-1211

BENNETT J ROBERTS, JR.
SBOT #17032000
P.O. DRAWER Q
RICHMOND, TEXAS 77469
(713) 342-9636

Jones/Roseman & Wiseman
A Law Firm of
Professional Corporations
12603 Southwest Freeway
Suite 360
Stafford, Texas
77477

Telephone 974-1212
Area Code 713

FILED

APR 10 1991

AT 10:40 AM *[Handwritten]*

Check Contact Court For Bond Co. Ex

REC. VOL. 54 PG 120

CERTIFICATE OF LAST KNOWN ADDRESS

This is to certify that the last known mailing address of the Defendant(s) is
639 COEN AVENUE, ROSHARON, TEXAS 77583.



PERRY G WISEMAN

Jones/Roseman & Wiseman
A Law Firm of
Professional Corporations
2603 Southwest Freeway
Suite 300
Stafford, Texas
77477
Telephone 974 1212
Area Code 713

EXHIBIT "A"

LEGAL DESCRIPTION

LOT 49, BLOCK 2, ARCOLA FARMS, A SUBDIVISION IN THE M. ESCALERA SURVEY IN FORT BEND COUNTY, TEXAS, ACCORDING TO THE PLAT OF SAID ARCOLA FARMS SHOWN OF RECORD IN VOLUME 4, PAGE 20 OF THE PLAT RECORDS OF FORT BEND COUNTY, TEXAS

AMOUNT DUE FORT BEND INDEPENDENT SCHOOL DISTRICT:
ACCOUNT #1150-00-002-4900-9070:

<u>Delinquent tax year</u>	<u>Base tax due</u>	<u>Total Tax & P/I due 4/91</u>	<u>Adjudged Value</u>
1977	\$164.50	\$460.64	
1978	\$171.55	\$468.54	
1979	\$176.25	\$469.22	
1980	\$273.68	\$709.72	
1981	\$266.22	\$682.72	
1982	\$278.66	\$676.17	
1983	\$306.02	\$700.33	
1984	\$303.53	\$652.74	
1985	\$450.80	\$907.24	
1986	\$450.80	\$845.02	
1987	\$427.40	\$742.18	
1988	\$414.18	\$662.07	
1989	\$424.80	\$620.43	
1990	\$435.42	\$483.32	\$35,400.00
		<u>\$9,080.34</u>	

AMOUNT DUE STATE OF TEXAS, COUNTY OF FORT BEND:

<u>Delinquent tax year</u>	<u>Base tax due</u>	<u>Total Tax & P/I due 4/91</u>	<u>Adjudged Value</u>
1975-1977, 1979, 1981-1986, 1988-1990	\$1,332.31	\$2,559.56	\$35,400.00

NO 71,457

FORT BEND INDEPENDENT SCHOOL DISTRICT	{	IN THE DISTRICT COURT OF
	{	
VS	{	FORT BEND COUNTY, TEXAS
	{	
EDWARD AUSTIN	{	240TH JUDICIAL DISTRICT

AFFIDAVIT

STATE OF TEXAS	{
	{
COUNTY OF FORT BEND	{

BEFORE ME, the undersigned authority, on this date personally appear SERGIO DELGADO known to me to be the Tax Assessor/Collector for FORT BEND INDEPENDENT SCHOOL DISTRICT and upon being duly sworn did depose a state as follows.

My name is SERGIO DELGADO I am the duly appointed Tax Assessor/Collector for FORT BEND INDEPENDENT SCHOOL DISTRICT. All statements and testimony made within this affidavit are made within my personal knowledge and I further have the authority to make such statements on behalf of FORT BEND INDEPENDENT SCHOOL DISTRICT.

FORT BEND INDEPENDENT SCHOOL DISTRICT is a duly incorporated political subdivision within FORT BEND County, Texas, and has the authority and power to levy and collect ad valorem taxes

All taxes due FORT BEND INDEPENDENT SCHOOL DISTRICT as reflected in Exhibit "A" attached hereto and incorporated herein for all purposes, were properly levied against the property described in said Exhibit "A" and owned by the Defendant(s). Although demand has been made upon said Defendant(s) to pay all tax, penalty and interest due FORT BEND INDEPENDENT SCHOOL DISTRICT, said Defendant(s) has refused to do so and said amounts remain delinquent and unpaid

I do hereby certify that the information contained on Exhibit "A" attached hereto and incorporated herein, properly reflects the entries contained in the delinquent tax roll of FORT BEND INDEPENDENT SCHOOL DISTRICT with regard to the legal description of the property made the basis of this action, the tax, penalty, and interest

due FORT BEND INDEPENDENT SCHOOL DISTRICT, and the adjudged value of the property made the basis of this suit Each and every such entry is true and correct within my personal knowledge unto which I certify herein.

SERGIO DELGADO, Tax
Assessor/Collector for
FORT BEND I.S.D.

SUBSCRIBED TO AND SWORN TO before me on this 13th day of Feb.

1991



NOTARY PUBLIC IN AND FOR
THE STATE OF TEXAS
My Commissioner Expires: Nov. 12, 199

EXHIBIT "A"

LEGAL DESCRIPTION

LOT 49, BLOCK 2, ARCOLA FARMS, A SUBDIVISION IN THE M. ESCALERA SURVEY IN FORT BEND COUNTY, TEXAS, ACCORDING TO THE PLAT OF SAID ARCOLA FARMS SHOWN OF RECORD IN VOLUME 4, PAGE 20 OF THE PLAT RECORDS OF FORT BEND COUNTY, TEXAS

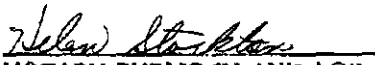
AMOUNT DUE FORT BEND INDEPENDENT SCHOOL DISTRICT:
ACCOUNT #1150-00-002-4900-9070:

<u>Delinquent tax year</u>	<u>Base tax due</u>	<u>Total Tax & P/I due 4/91</u>	<u>Adjudged Value</u>
1977	\$164.50	\$460.64	
1978	\$171.55	\$468.54	
1979	\$176.25	\$469.22	
1980	\$273.68	\$709.72	
1981	\$266.22	\$682.72	
1982	\$278.66	\$676.17	
1983	\$306.02	\$700.93	
1984	\$303.53	\$652.74	
1985	\$450.80	\$907.24	
1986	\$450.80	\$845.02	
1987	\$427.40	\$742.18	
1988	\$414.18	\$662.07	
1989	\$424.80	\$620.43	
1990	\$435.42	\$483.32	\$35,400.00

AMOUNT DUE STATE OF TEXAS, COUNTY OF FORT BEND:

<u>Delinquent tax year</u>	<u>Base tax due</u>	<u>Total Tax & P/I due 4/91</u>	<u>Adjudged Value</u>

TAX STATEMENT

Account Number 1150000024900907
 Legal ARCOLA FARMS, BLOCK 2, LOT
 49, ACRES 1.0

Market Value 35,400
 Exemptions NONE
 Effective Date 04/02/91

Items due include

Unit	Year	Levy Due	Pen / Int	Fees	Total
STATE	75	1.68	2.61	.64	4.93
FBC-DF	75	3.50	5.44	1.34	10.28
FBC-LRFC	75	4.20	6.53	1.61	12.34
FBC-GF	75	13.30	20.68	5.10	39.08
STATE	76	1.68	2.51	.63	4.82
FBC-DF	76	3.50	5.23	1.31	10.04
FBC-LRFC	76	4.20	6.28	1.57	12.05
FBC-GF	76	13.30	19.88	4.98	38.16
STATE	77	1.40	2.01	.51	3.92
FBC-DF	77	3.50	5.02	1.28	9.80
FBC-LRFC	77	4.20	6.03	1.53	11.76
FBC-GF	77	13.30	19.09	4.86	37.25
STATE	79	3.13	4.12	1.09	8.34
FBC-DF	79	6.89	9.06	2.39	18.34
FBC-LRFC	79	9.39	12.35	3.26	25.00
FBC-GF	79	29.74	39.11	10.33	79.18
FBC-DF	81	9.39	11.55	3.14	24.08
FBC-LRFC	81	11.74	14.44	3.93	30.11
FBC-GF	81	47.73	58.71	15.97	122.41
FBC-LRFC	82	14.93	16.57	4.73	36.23
FBC-DF	82	19.90	22.09	6.30	48.29
FBC-GF	82	73.40	81.47	23.23	178.10
FBC-LRFC	83	14.93	14.78	4.46	34.17
FBC-DF	83	19.90	19.70	5.94	45.54
FBC-GF	83	67.18	66.51	20.05	153.74
FBC-LRFC	84	14.93	12.99	4.19	32.11
FBC-DF	84	19.90	17.31	5.58	42.79
FBC-GF	84	67.18	58.45	18.84	144.47
FBC-DF	85	17.26	12.95	4.53	34.74
FBC-LRFC	85	17.49	13.12	4.59	35.20
FBC-GF	85	101.06	75.80	26.53	203.39
FBC-DF	86	16.64	10.48	4.07	31.19
FBC-LRFC	86	18.30	11.53	4.47	34.30
FBC-GF	86	116.28	73.26	28.43	217.97
FBC-LRFC	88	15.29	5.96	3.19	24.44
FBC-DF	88	19.22	7.50	4.01	30.73
FBC-GF	88	129.49	50.50	27.00	206.99
FBC-LRFC	89	14.51	3.92	2.76	21.19

***CONTINUATION PAGE ***

TAX CERTIFICATE CONTINUED
 ON THE NEXT PAGE OR ON

 **AUSTIN EDWARD *
 **639 COEN AVE *
 ** *
 ** *
 ** 775830000 *

TAX STATEMENT

Legal ARCOLA FARMS, BLOCK 2, LOT 49, ACRES 1.0

Effective Date 04/02/91

*** CONTINUATION

Unit	Year	Levy Due	Pen / Int	Fees	Total
FBC-DF	89	24.46	6.60	4.66	35.72
FBC-GF	89	146.06	39.44	27.83	213.33
FBC-LRFC	90	14.58	1.60	2.43	18.61
FBC-DF	90	23.29	2.56	3.88	29.73
FBC-GF	90	160.36	17.64	26.70	204.70

Total due for

Levy 1,332.31
P&I 893.38
Fees 333.87

Total 2,559.56 Due

* AUSTIN EDWARD *
* 639 COEN AVE *
* *
* *
* ROSHARON, TX 77583 *

I hereby certify that the foregoing is a true and correct copy from the records of my office as the same appears in the delinquent tax records therein.

In testimony whereof, witness my hand and seal of office this 4th day of April, 1991.

MARSHA P. GAINES, Tax Assessor/Collector for the County of Fort Bend, Texas

Patsy Schubert
DEPUTY

NO. 71,457

FORT BEND INDEPENDENT * IN THE DISTRICT COURT OF
 SCHOOL DISTRICT *
 *
 VS. * FORT BEND COUNTY, TEXAS
 *
 EDWARD AUSTIN AND JIMMIE * 240TH JUDICIAL DISTRICT
 MAE AUSTIN *

AFFIDAVIT IN SUPPORT OF ATTORNEY'S FEES

STATE OF TEXAS)
 COUNTY OF FORT BEND)

BEFORE ME, the undersigned official, on this day appeared BENNETT J. ROBERTS, JR., who is personally known to me, and first being duly sworn according to law upon his oath deposed and said:

"My name is Bennett J. Roberts, Jr., attorney for COUNTY OF FORT BEND. I am over 18 years of age, and am a resident of Houston, Texas. I am fully competent to make this Affidavit. I have personal knowledge of the facts stated herein, and they are all true and correct.

1. I am an attorney, licensed in the State of Texas since 1958;
2. I practice regularly in Fort Bend County as the attorney for State of Texas, County of Fort Bend;
3. I practice regularly in the area of delinquent property tax collections, and know that the usual and customary fee for such work is 15% of the delinquent tax, penalty and interest due to the taxing unit;
4. Such fee in this case is \$33.01 which is a reasonable and necessary amount for work of this nature.
5. In addition to attorneys fees, expenses in determining the name, identity and location of necessary parties and in procuring necessary legal description of the property in this suit have incurred. I am familiar with the amount charged by other attorneys, taxing units and abstractors for work of this nature, and attest that the amount of \$33.01 is a reasonable and necessary cost incurred for such work."

Bennett J. Roberts, Jr.
 BENNETT J. ROBERTS, JR.

SWORN TO AND SUBSCRIBED BEFORE ME on this 10TH day of APRIL, 1991, to certify which witness my hand and official seal.



Sharon Macha
 Notary Public, State of Texas

CAUSE NO. 71,457

MAY 03 91

THE STATE OF TEXAS:

TO any Sheriff or any Constable Within the State of TEXAS-GREETINGS:

WHEREAS, on the 10TH day of APRIL, 1991, FORT BEND INDEPENDENT SCHOOL DISTRICT AND STATE OF TEXAS, COUNTY OF FORT BEND recovered in the District Court of Fort Bend County for the 240th Judicial District of Texas, a judgment against EDWARD AUSTIN for taxes, interest, penalties, expenses of suit, and costs of court as follows: FORT BEND INDEPENDENT SCHOOL DISTRICT recovered the sum of \$9,080.34, in tax, penalty and interest, together with interest thereon at the rate of 12% per annum from the date of judgment until fully paid; STATE OF TEXAS, COUNTY OF FORT BEND recovered the sum of \$2,559.56, in tax, penalty and interest, together with interest thereon at the rate of 12% per annum from the date of judgment until fully paid, and the further sum of \$199.00 being all Court Costs; all of said amounts being fully set forth in the Judgment. Whereas, the Judgment constituted a foreclosure of the lien for taxes due to the Plaintiff(s) and Intervenors, if any, upon the following described property:

PROPERTY DESCRIPTION CONTAINED IN EXHIBIT "A" ATTACHED

OFFICERS RETURN:

31 DAY OF MAY 1991
AUGUSTED ON THE 2ND DAY OF JULY 1991 BY HELD SALE
NO BIDDERS, PROPERTY STRUCK OFF TO PLAINTIFF
COSTS TO BE PAID & COLLECTED BY PLAINTIFF

91 JUL 10 PM 12:11
[Handwritten signature]

40.00

Juan Diaz #1302



TAX ASSESSOR/COLLECTOR

FORT BEND COUNTY, TEXAS

MARSHA P GAINES

(281) 341-3710
Fax (281) 341-9267

DATE. September 30, 1999

TO. Mr. Bud Childers
Fort Bend County Attorney

FROM: Karen Stell
Assistant Division Supervisor - Taxes

RE. Resale of Property taken under Cause 80,176
Lamar CISD vs. ~~Linda~~ Munoz et.al
LOUISA

Attached is the letter received from Ray, Wood, and Fine, delinquent attorneys for Lamar CISD, requesting resale of property taken under Cause 80,176.

Also, original deed attached: Lamar CISD/Fort Bend County(Grantor) City of Rosenberg (Grantee)

Ray, Wood, and Fine request this be placed on the Commissioner's Court Agenda so they may approve or disapprove this sale. Please have the appropriate party sign both documents, if approved. Then, return the originals to me

Please review and place on the agenda. Contact me at 281-341-3723 if you have any questions.

cc: Sharon Macha
Ray, Wood, and Fine

Ray, Wood, Fine-093099-lcs

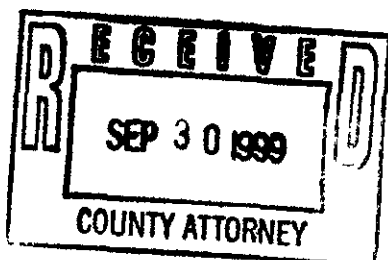

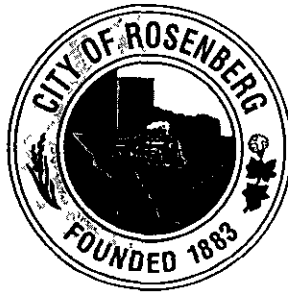

April 20, 1999

Mr Bennet Roberts
Ray, Wood & Fine, L L.P
1021 Eighth Street
Rosenberg, Texas 77471

RE Resale of Property taken under Cause #80,176, Lamar CISD vs Louisa Munoz, et al,
4415-00-0040-901

Dear Mr Roberts:

Attached is a copy of a memo to Mayor Ryan from Karen Stell concerning the resale of the Munoz, et al property

The City is most anxious to have possession of this property The right-of-way for the proposed FM723 Overpass is scheduled to cross this small tract of land

The tract is 0 059 of an acre. The right-of-way will consume 0 052 acres of the tract The balance of the two very small remainders will remain in the ownership of the City The balance of all properties acquired that are not needed for the 100' right-of-way will remain in open space and maintained like a park

This new overpass will add greatly to the efficiency of the City's operations, circulation of school busses and public transportation There are over 20 trains per day traveling through Rosenberg It is projected that this traffic will increase to 57 trains per day in the next seven years

I appreciate your willingness to prepare the necessary documents for the School District agenda which would provide the City with this much needed parcel of land

Sincerely,

Jim Bell
Director of Community Development

JB/rc

cc Jeff D Braun, City Manager
Charles A Kalkomey, City Engineer
Firmin A Hickey City Attorney

a /reading rd/roberts 1

2/11/97

CONSTABLE'S DEED

COPY

THE STATE OF TEXAS

§

KNOW ALL MEN BY THESE PRESENTS:

§

COUNTY OF FORT BEND

§

THAT WHEREAS, by virtue of a certain Order of Sale in that certain Tax Suit issued out of the 268th Judicial District Court of Fort Bend County, Texas, in Cause No 80,176 on the 14TH of APRIL, 1997, in favor of LAMAR CONSOLIDATED INDEPENDENT SCHOOL DISTRICT, Plaintiff, and Intervenor, STATE OF TEXAS, COUNTY OF FORT BEND and CITY OF ROSENBERG, against EMILY MUNOZ and ANY AND ALL UNKNOWN HEIRS OF LOUISA MUNOZ in a certain judgment and decree, rendered on the 10TH day of NOVEMBER, 1993, and directed and delivered to me as Constable, Precinct #1, Fort Bend County, Texas, commanding me to seize and sell the premises described in said Order of Sale, I, A J Dorr, Constable, Precinct #1, Fort Bend County, Texas, did, upon the 14TH day of APRIL, 1997, levy upon and advertise for sale the said land and premises described in said Order of Sale, by having a notice of the sale published in the English language once a week for three consecutive weeks preceding the day of the sale in the Herald Coaster, a newspaper published in Fort Bend County, Texas, the first of said publications appearing not less than twenty days immediately preceding the day of the sale, said Notice of Sale containing a statement of the authority by virtue of which the sale is to be made, the time of levy, time and place of sale, also a brief description of the property to be sold, the number of acres, original survey, locality in the county, and the name by which the land is most generally known I also mailed to the above named defendant a notice of the sale, directed to him at his last known address

On the first Tuesday in MAY, 1997, same being the 6TH day of MAY, 1997, between the hours of ten o'clock a m , and four o'clock p m , I sold said described land and premises at public vendue at the North door of the Court House of said Fort Bend County, in the City of Richmond, Texas, at the hour of ten o'clock a m and the premises hereinafter described were struck off to Plaintiff, LAMAR CONSOLIDATED INDEPENDENT SCHOOL DISTRICT, IN TRUST, for the use and benefit of itself and all other taxing units that established tax liens in Cause Number 80,176, in the 268th Judicial District Court of Fort Bend County, Texas, for the amount of taxes owing, including interest and penalties

NOW THEREFORE, I, A J DORR, Constable, Precinct #1, Fort Bend County, Texas, have GRANTED, SOLD and CONVEYED, and by these presents do GRANT, SELL and CONVEY unto the said Plaintiff, LAMAR CONSOLIDATED INDEPENDENT SCHOOL DISTRICT, IN TRUST, for the use and benefit of itself and all other taxing units that established tax liens in Cause Number 80,176, in the 268th Judicial District Court of Fort Bend County, Texas, all of the estate, right, title and interest which the said EMILY MUNOZ and ANY AND ALL UNKNOWN HEIRS OF LOUISA MUNOZ had on the 6TH day of MAY, 1997, or at any time afterwards, in and to the following land and premises as described in said Order of Sale, viz

KAFFENBERGER ADDITION, BLOCK 3, LOT 4, SITUATED IN FORT BEND COUNTY, TEXAS, SHOWN OF RECORD IN DEED DATED JANUARY 10, 1939, RECORDED IN VOLUME 180 PAGE 192 OF THE REAL PROPERTY RECORDS OF FORT BEND COUNTY, TEXAS

TO HAVE AND TO HOLD the above described land and premises unto the said Plaintiff, LAMAR CONSOLIDATED INDEPENDENT SCHOOL DISTRICT, IN TRUST, for the use and benefit of itself and all other taxing units that established tax liens in Cause Number 80,176, in the 268th Judicial District Court of Fort Bend County, Texas, its successors and assigns subject, however, to the right of defendant to redeem the same in the manner prescribed by law within 6 MONTHS from the date of the filing of record of this deed, and to such other and further conditions and stipulations as may be applicable under the provisions of Section 34 21, of the Texas Property Tax Code, as fully and absolute as I, Constable, Precinct #1, Fort Bend County, Texas, aforesaid, can convey by virtue of said Order of Sale

Grantees Address

LAMAR CONSOLIDATED INDEPENDENT SCHOOL DISTRICT, IN TRUST
3911 AVENUE I
ROSENBERG, TEXAS 77471

IN TESTIMONY WHEREOF, I have hereunto set my hand, this 28TH day of May, 1997

A J Dorr, Constable, Precinct #1
Fort Bend County, Texas

THE STATE OF TEXAS §
COUNTY OF FORT BEND §

Before me, a Notary Public in and for the State of Texas, on this day personally appeared A J Dorr, Constable, Precinct #1, Fort Bend County, Texas, known to me to be the person whose name is subscribed to the foregoing instrument, and acknowledged to me that he executed the same as Constable, Precinct #1, Fort Bend County, Texas, for the purposes and consideration therein expressed and in the capacity therein stated

GIVEN UNDER MY HAND and seal of office, this 28TH day of May, 1997

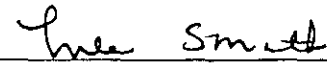
Notary Public in and for The State of Texas

After Recording Return To

Ray, Wood & Fine, L.L P.
1021 Eighth Street
Rosenberg, Texas 77471

Prepared in the Law Office of
Ray, Wood & Fine, L L P

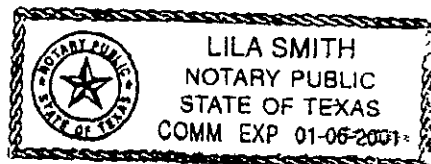

NOTED ORIGINAL

FILED AND RECORDED
OFFICIAL PUBLIC RECORDS

Dianne Wilson

8-7-97 11:00 AM 9749521
TD \$11.00
DIANNE WILSON, County Clerk
FORT BEND COUNTY, TEXAS

COPY

NO. 80,176

LAMAR CONSOLIDATED	{	IN THE DISTRICT COURT
INDEPENDENT SCHOOL DISTRICT	{	
VS.	{	268TH JUDICIAL DISTRICT
	{	
LOUISA MUNOZ, ET AL	{	FORT BEND COUNTY, TEXAS

JUDGMENT

The above entitled and numbered cause came on to be heard.

1. APPEARANCES

Plaintiff is Lamar Consolidated Independent School District on behalf of itself and Fort Bend County Education District. Intervenor are State of Texas, County of Fort Bend, et al; and City of Rosenberg. All have appeared through their attorney of record and announced ready for trial. On Plaintiff's motion, the Court dismissed from this suit any other taxing units not named here as Plaintiff and Intervenor.

Defendants are:

- (1) Emily Munoz
- who () appeared in person and by attorney and announced ready for trial
- () heretofore appeared by filing a written answer, but who otherwise failed to appear at the trial of this cause after proper notice of this setting.
- (X) though legally and duly served with citation in the time and manner prescribed by law, failed to appear or answer herein and wholly made default. It further appears that the citation served, with the officer's return thereon, has been on file with the Clerk of the Court ten days exclusive of the day of filing and the day of judgment.
- () did not appear in person but agrees to the entry of this judgment evidenced by the signature(s) below.
- () Other:

- (2) Any and All Unknown Heirs of Louisa Munoz
- who (X) was duly served with process by publication; behalf of whom the Court appointed Charles Foster attorney ad litem to defend this suit, and whom appeared and announced ready for trial.

FILE COPY

2. PROCEEDINGS

No jury having been demanded, the Court proceeded to consider the evidence, including certified copies of the delinquent tax records, and to hear argument in support of this cause of action brought to recover delinquent ad valorem taxes.

3. FINDINGS

The Court makes the following findings:

- (1) Delinquent taxes, penalties and interest are due to Plaintiff by reason of ownership of the property described on the attached Exhibit(s).
- (2) Said taxes are delinquent for the tax years shown on the attached Exhibit(s).
- (3) The amount of taxes, penalties and interest which are delinquent and due to Plaintiff is as shown on the attached Exhibit(s).
- (4) Delinquent taxes, penalties and interest are also due the Intervenor for tax years as shown on the attached exhibits.
- (5) Said taxes, penalties and interest constitute a separate, valid, and subsisting lien for each respective tax year in favor of Plaintiff and Intervenor on each property hereinafter described to secure the payment of the taxes, penalties and interest herein adjusted to be due against said property, which lien is first, prior and superior to any claims, right, title, interest or lien asserted by any Defendant hereto.
- (6) Defendants were the owners of record of the property, or were claiming some right, title or interest thereto,
 - (X) on January 1 of the year(s) for which the taxes were imposed.
 - (X) at the time of the institution of this suit.
 - (X) at this time.
- (7) The property was located within the boundaries of Plaintiff and Intervenor and was taxable by Plaintiff and Intervenor when the taxes found to be due were assessed. The market value of the property above on the date of trial is as shown on the attached Exhibit(s).
- (8) Plaintiff is entitled to recover expenses of \$284.80, which is a reasonable amount incurred in determining the name, identity, and location of necessary parties and in procuring necessary legal descriptions of the property.
- (9) Defendant's attorney ad litem is entitled to recover reasonable attorney's fees in the amount of \$ 375.00.

4. ORDERS

The Court makes the following orders that are marked by X's or checks below:

- 1987 =
12-10-
92
- (X) IT IS ORDERED that Plaintiff does have and recover the amount of \$593.56 ✓ as shown on the attached Exhibit(s), the additional sum of \$284.80 ✓ for reasonable expenses, and all usual court costs herein incurred, all court costs which may hereafter be incurred in the collection of this judgment if same be necessary, which sum shall bear interest at the maximum legal rate of 10% per annum from the date of judgment until paid, and expenses of foreclosure sale (if any). The Clerk shall issue all execution and other process necessary to enforce the judgment.
- 1987 =
12-10-
92
- (X) IT IS ORDERED that Intervenor, State of Texas, County of Fort Bend, et al, does have and recover the amount of \$229.68 ✓ as shown on the attached Exhibit(s), and all usual court costs herein incurred, all court costs which may hereafter be incurred in the collection of this judgment if same be necessary, which sum shall bear interest at the maximum legal rate of 10% per annum from the date of judgment until paid, and expenses of foreclosure sale (if any). The Clerk shall issue all execution and other process necessary to enforce the judgment.
- 1987 =
12-10-
92
- (X) IT IS ORDERED that Intervenor, City of Rosenberg, does have and recover the amount of \$ 327.89 ✓ as shown on the attached Exhibit(s), and all usual court costs herein incurred, all court costs which may hereafter be incurred in the collection of this judgment if same be necessary, which sum shall bear interest at the maximum legal rate of 10% per annum from the date of judgment until paid, and expenses of foreclosure sale (if any). The Clerk shall issue all execution and other process necessary to enforce the judgment.
- (X) IT IS ORDERED that Defendant's attorney ad litem is entitled to recover reasonable attorney's fees in the amount of \$ 375.00.
- (X) IT IS ORDERED that Plaintiff and Intervenor shall have foreclosure of their liens on the property as against each Defendant or any person claiming under any Defendant by any right acquired pending this suit.
- (X) IT IS ORDERED that an Order of Sale be issued by the Clerk directed to the Sheriff or any Constable of said County, commanding such officer to seize, levy upon, and advertise the sale of each of said properties, and sell the same to the highest bidder for cash, as under execution, provided that none of said property shall be sold to any party, other

than a taxing unit which is party to the suit, for less than the amount of the market value of the property (as shown in the findings portion of this judgment) or the aggregate amount of the judgment against the property in said suit, whichever is lower. If the owner of said property, in person or by attorney, shall at any time before the sale file with the Sheriff or other officer in whose hands said order of sale shall be placed a written request that the property described therein shall be divided and sold in less tracts than the whole, together with a description of said subdivisions, then such officer shall sell the land in such subdivisions as said owner may request and, in such case, shall only sell as many subdivisions as necessary to satisfy this judgment, interest and costs. The net proceeds of any sale of such property made hereunder to any party other than a taxing unit who is a party to this suit to be applied to satisfy the judgment and liens foreclosed herein, but any excess in the proceeds of sale over and above the amount necessary to pay the taxes due, defray the costs of suit and sale and other expenses chargeable against said property, shall be paid to the parties legally entitled to such excess. The owner of such property, or anyone having an interest therein, or their heirs, assigns, or legal representatives may redeem such property in the time and manner prescribed by law. The officer executing the order of sale shall make proper conveyance to the purchaser or purchasers of said property, as prescribed by law, subject to such right of redemption. If, before the expiration of the period of redemption fixed by law, no person who is entitled to redeem the property has exercised their right of redemption, then a writ of possession shall be issued to the purchaser at foreclosure sale or his assigns by the Clerk of this Court within twenty days after the period of redemption shall have expired, ordering the Sheriff or proper officers to place the purchaser or purchasers or their heirs, executors, assigns, or administrators, in possession of the property so purchased in accordance with the laws of the State of Texas.

All relief prayed for in the pleadings in this cause which is not specifically granted by this judgment is hereby denied.

SIGNED ON THIS 10 day of Nov, 1993.

191

JUDGE PRESIDING

RAY, WOOD & FINE, L.L.P.

HEARD, GOGGAN, BLAIR & WILLIAMS

By:

Bernadette Baca Gonzalez
Raymond R. Gray
State Bar No. 08328250
Bernadette Baca Gonzalez
State Bar No. 08124080
ATTORNEY FOR PLAINTIFF
(Lamar C.I.S.D.)

P. O. Box 165001
Austin, Texas 78716
(512) 328-6970
1-800-568-1582
(512) 328-9386

ATTORNEY AD LITEM

By:

Bennett Roberts, Jr.
Bennett Roberts, Jr.
State Bar No. 17032000
ATTORNEY FOR INTERVENOR
(State of Texas, County
of Fort Bend, et al)

415 South 4th Street
P. O. Drawer Q
Richmond, Texas 77409
(713) 342-9636
(713) 341-7808

PERDUE, BRANDON, FIELDER,
COLLINS & MOTT

By:

Charles Foster
Charles Foster
State Bar No. 07284500
12926 Dairy Ashford Rd.,
Suite #100
Sugarland, Texas 77478
(713) 242-3500
(713) 240-2479 (FAX)

By:

Michael J. Darlow
Michael J. Darlow
State Bar No. 05387300
ATTORNEY FOR INTERVENOR
(City of Rosenberg)
2600 Citadel Plaza Dr. #110
Houston, Texas 77008
(713) 862-1860
1-800-833-5886
(713) 862-1429 (FAX)

Delinquent Taxes Itemized on a Yearly Basis for 079901.4415000030040901
(Lamar Consolidated Independent School District)
Kaffenberger Addn, Block 3, Lot 4

Munoz Est., Louisa M.
% Emily Munoz
711 Barrett St.
Richmond, TX 77469-3610

YEAR	DISTRICT	For Month of NOV		TOTAL
		BASE TAX	PENALTY & INTEREST	
1987	LCISD	\$122.59	\$133.99	\$256.58
1988	LCISD	\$122.59	\$117.07	\$239.66
1989	LCISD	\$14.13	\$11.55	\$25.68
1990	LCISD	\$13.90	\$9.43	\$23.33
1991	LCISD	\$6.77	\$3.66	\$10.43
1992	LCISD	\$6.78	\$2.73	\$9.51
1991	LCCED	\$9.10	\$4.92	\$14.02
1992	LCCED	\$10.23	\$4.12	\$14.35
-	Subtotals	\$306.09	\$287.47	\$593.56
	Balance Due			\$593.56

Market Value \$1,130.00

RAY, WOOD & FINE, L L P
ATTORNEYS AT LAW
1021 EIGHTH STREET
ROSENBERG, TEXAS 77471
(281) 344-9844
FAX (281) 344-8751

SEP 13 1999

BENNETT J ROBERTS JR
ATTORNEY

September 14, 1999

Ms Karen Stell
Fort Bend County Tax Office
P O Box 399
Richmond, Texas 77406

Re The Resale of Property Taken Under Cause No 80,176,
Lamar CISD vs Louisa Munoz, et al

Dear Ms Stell

The following information is provided to you in order to submit a proposal to the Commissioner's Court on behalf of Fort Bend County for the resale of the above referenced property. The bid that was received, reviewed, and approved by the Lamar Consolidated Independent School District is less than the amount of taxes due to all taxing authorities, therefore, the approval of the County is needed.

Said proposal was submitted by CITY OF ROSENBERG on August 4, 1999. Attached is a copy of a letter from the CITY OF ROSENBERG stating that the City is interested in acquiring this property for the proposed FM 723 Overpass site. The amount of taxes under judgment for all taxing units total \$1,552.29.

The following is a breakdown of costs involved in the execution and foreclosure of the above referenced property:

Court Costs	\$ 179.00	Glory Hopkins, District Clerk
Abstract Fees	\$ 216.87	Ray, Wood & Fine
Attorney Ad Litem	\$ 375.00	Charles Foster
Cost of Execution	\$ 185.78	A J Dorr, Constable, Pct 1
Publication Fees	\$ 208.25	Ray, Wood & Fine
TOTAL COSTS	\$ 1,164.90	

There will be no disbursement of funds to the taxing authorities. This property will be used for the proposed FM 723 Overpass site by the City of Rosenberg.

All years should be removed from the account.

I have enclosed the Quit Claim Deed for the signature of the County, if it is approved. If approved, please have signed and return the original deed to our office Thank you for your cooperation in this matter

If you have any questions, please feel free to give me a call at (281) 344-9844

Sincerely,

Sharon Macha
Litigation Supervisor

APPROVED, AGREED TO AND ACCEPTED:

FORT BEND COUNTY

BY



Title. County Judge

Date: 10-12-99

QUITCLAIM DEED

STATE OF TEXAS *
*
COUNTY OF FORT BEND *

KNOW ALL MEN BY THESE PRESENTS

That this, the LAMAR CONSOLIDATED INDEPENDENT SCHOOL DISTRICT, as Trustee for itself and the STATE OF TEXAS, COUNTY OF FORT BEND, for and in consideration of the sum of (\$10 00) TEN DOLLARS AND NO/100 and other good and valuable consideration in hand paid by CITY OF ROSENBERG, of the County of Fort Bend, State of Texas, the receipt of which is hereby acknowledged, HAVE QUITCLAIMED, and by these presents DO QUITCLAIM unto said Grantees, their heirs, and assigns, all of its right, title, and interest in and to the following described real property situated in Fort Bend County, Texas, to wit

KAFFENBERGER ADDITION, BLOCK 3, LOT 4, SITUATED IN FORT BEND COUNTY, TEXAS, SHOWN OF RECORD IN DEED DATED JANUARY 10, 1939, RECORDED IN VOLUME 180 PAGE 192 OF THE REAL PROPERTY RECORDS OF FORT BEND COUNTY, TEXAS ACCOUNT NO 4415-00-003-0040-901

TO HAVE AND TO HOLD all of its right, title, and interest in and to the said premises, as recited in the Sheriff's Deed recorded in Clerk's File No 9749521, Fort Bend County Deed records, together with all and singular the rights, privileges, and appurtenances thereto in any manner belonging unto the said Grantees, their heirs, and assigns forever, so that neither LAMAR CONSOLIDATED INDEPENDENT SCHOOL DISTRICT, Trustee nor its heirs, legal representatives, nor any person or persons claiming under it shall at any time thereafter have, claim, or demand any right or title to the aforesaid property, premises, or appurtenances, or any part thereof

IT IS EXPRESSLY ACKNOWLEDGED that the Sheriff's Deed referenced above provides for the Defendant's right of redemption, pursuant to TEX CODE ANN {34.21 (1982)

Executed this 13 day of October, 1999

Dan Ives, Superintendent
LAMAR CONSOLIDATED I.S D

GRANTORS

ACKNOWLEDGMENT

STATE OF TEXAS {
 {
COUNTY OF FORT BEND {

This instrument was acknowledged before me on the _____ day of _____,
1999, by _____

Notary Public in and for the
State of Texas

Commission expires _____

Executed this 13 day of October, 1999

J.C.R.
County Judge
STATE OF TEXAS, COUNTY OF FORT BEND

GRANTORS

ACKNOWLEDGMENT

STATE OF TEXAS {
 {
COUNTY OF FORT BEND {

This instrument was acknowledged before me on the 13 day of October,
1999, by James C Adolphus

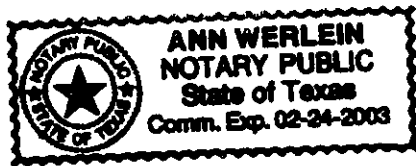

Ann Werlein
Notary Public in and for the
State of Texas

Commission expires 2-24-2003

**FORT BEND COUNTY
COMMISSIONERS COURT AGENDA REQUEST FORM**

RETURN TO AGENDA COORD -COUNTY JUDGE'S OFFICE

DATE SUBMITTED: 9-30-99

DEPT SUBMITTED BY: TREASURER

COMMISSIONERS COURT AGENDA FOR: October 12, 1999 DEPT. PHONE NO: ext 3750

12

SUMMARY OF ITEM:

FLOOD CONTROL WATER SUPPLY CORPORATION MONTHLY BILLS

RENEWAL CONTRACT/AGREEMENT. Yes () No

LIST SUPPORTING DOCUMENTS ATTACHED REQUISITION CERTIFICATES
(Back-up documentation must be attached for consideration)

FINANCIAL SUMMARY:

BUDGETED ITEM:			ANNUALIZED DOLLARS:		COMMENTS:
Yes ()	No ()	N/A <input checked="" type="checkbox"/>	One Time	()	
Funding Source:			Recurring	()	
fund <u>264</u>	agcy <u>006</u>	Object <u>4010</u>	N/A	<input checked="" type="checkbox"/>	
<u>265</u>	<u>006</u>	<u>4010</u>			

Original Form Submitted with back up to County Judge's Office: Yes

CC with back up:

Auditor	(281-341-3774)	Comm. Pct. 1	(281-344-0587)
Budget Officer	(281-344-3954)	Comm. Pct. 2	(281-403-8009)
County Attorney	(281-341-4557)	Comm. Pct. 3	(281-242-9060)
Purchasing Agent	(281-341-8642)	Comm. Pct. 4	(281-980-9077)

Instructions for submitting an Agenda Request

1. Completely fill out agenda form, incomplete forms will not be processed.
2. Fax or inter-office copies of agenda form with all back up information by Wednesday at 2:00 p m. to the departments listed above.
3. All original back-up must be received in the County Judges Office by 2.00 p.m. on Wednesday.

RECOMMENDATION / ACTION REQUESTED:

Fort Bend Flood Control Water Supply Corporation
Fort Bend County, Texas

September 22, 1999

Ms Sharon Reynolds
500 Jackson
Jane Long Building, Room 103
Richmond, Texas 77469

Re Fort Bend Flood Control Water Supply Corporation, Agenda Items

Attached please find the bills approved for payment at the Corporation meeting today. Please add "Approve payment of bills" to the agenda for the Commissioners' Court Meeting on October 12, 1999. Thanks for your help. Please call me at 713-218-7612 if you have any questions.

Yours truly,



Gayle G Kennedy
Administrative Assistant



2929 Briarpark Drive
Suite 500
Houston, Texas 77042-3703

Phone 713 953 5200
Fax 713 953 5026

September 17, 1999

The Honorable Judge James C Adolphus
Fort Bend County Judge
County Courthouse
500 Jackson
Richmond, Texas 77469

Re: September 1999 Invoices
Fort Bend Flood Control Water Supply Corporation

Dear Judge Adolphus

The enclosed invoices for work performed by consultants, contractors and the Board of Directors for the Fort Bend Flood Control Water Supply Corporation (FBFCWSC) have been reviewed by the Fort Bend County Drainage District and the FBFCWSC Bill Review Committee. The invoices were discussed at the September 22, 1999 FBFCWSC meeting of the Board of Directors and approved for payment.

We request that you place this item on the Fort Bend County Commissioners Court agenda for approval at the regularly scheduled meeting of October 5, 1999

Daniel E. Gerken, P.E.
Manager
Fort Bend County Drainage District

Don Russell
President, Board of Directors
Fort Bend Flood Control Water Supply Corporation

DEG/DR/nh

File 0414-0201 (2.0)

Enclosures



**FORT BEND FLOOD CONTROL WATER SUPPLY CORPORATION
BILLS TO BE PAID**

September 22, 1999

Don Russell	Directors fee	\$ 100 00
Paul J Council	Directors fee	\$ 200 00
Jim Condrey	Directors fee	\$ 300 00
Rick Zapalac	Directors fee	\$ 200 00
A.J Colbert	Directors fee	\$ 100 00
Gayle G Kennedy	Services and Expenses for the month of September	\$ 362 07
District Data Services	Bookkeeping for July and August	\$ 865 10
LJA Land Development	Engineering from August 1 to through August 27, 1999	\$ 12,332.21
Bank of America	Account Analysis for August	\$ 82 98
 <u>Big Creek</u>		
Jones & Carter, Inc	Engineering from August 1 to August 28, 1999	\$ 65,716 48
Rick Zapalac	Directors fee	\$ 100 00
Jeff Council	Directors fee	\$ 100 00

+	+	+	+	+	+	+	+	+	+	+	*	
100.00	200.00	300.00	200.00	100.00	362.07	865.10	12,332.21	82.98	65,716.48	100.00	100.00	80,458.84

INVOICE TRANSMITTAL

12 Digit Distribution 265-006-2640-4010
Vendor Number 451588385
Purchase Order Number(s) REQ CERT 0017

Vendor Name PAUL JEFF COUNCIL		
Address P.O. BOX 1067		
City ROSENBERG		
State TX	Zip Code 77471	Date 9-28-99

Description / Invoice Number
DIRECTORS FEE FOR 1 meeting

Amount
100.00
Total \$ 100.00-

County Auditor's Use Only

Checked by _____

Audited by _____

Received _____

Paid _____



Authorized Departmental Approval

Treasurer's Register Stamp and Number

125630

COUNTY TREASURER
FORT BEND COUNTY
REGISTERED

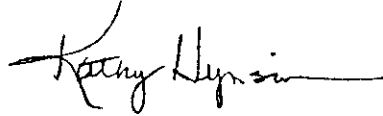
SEP 28 1999



REQUISITION CERTIFICATE NO. 0017

County Treasurer
Fort Bend County, Texas

Pursuant to Section 3 of the Reimbursement Agreement between Fort Bend Flood Control Water Supply Corporation (the "Corporation") and Fort Bend County Drainage District relating to the payment by the Corporation of its initial costs, such Agreement dated as of January 26, 1999, the County Treasurer of Fort Bend County is directed, upon execution of this certificate, to pay from the Corporation's Big Creek Construction Fund the amount of

to Paul J. Council \$ 100.00
for Directors fees for attending 1 meeting @ \$ 100.00 per meeting.

On behalf of the Corporation, I, the undersigned Representative, do hereby certify as follows.

(1) The above described obligation has been incurred and is presently due and payable and has not been paid, or has previously been paid and reimbursement for such payment is appropriate, and that said obligation is a proper charge against the Big Creek Construction Fund,

(2) Payment of such obligation is in conformance with the terms and conditions of the Agreement, and

(3) No Event of Default has occurred and is continuing

Approval of Payment from the Corporation's Big Creek Construction Fund maintained at NationsBank, Richmond Branch in the amount of \$ One hundred dollars and no/100

for the purpose(s) described above is evidenced by my manual signature hereon and the approval of the Commissioner's Court of Fort Bend County evidenced hereon

FORT BEND FLOOD CONTROL WATER
SUPPLY CORPORATION

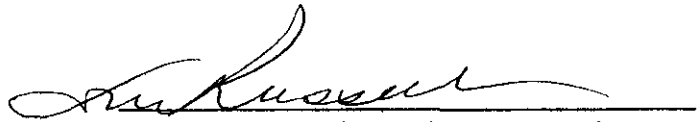

Don Russell, Authorized Representative

Date 9-22-99

INVOICE TRANSMITTAL

12 Digit Distributor 265-006-2640-4010
Vendor Number 741848244
Purchase Order Number (S) REQ CERT 0015

Vendor Name JONES & CARTER, INC.		
Address 6335 GULFTON, SUITE 200		
City HOUSTON		
State TX	Zip Code 77081	Date 9-28-99

Descriptor	Invoice Numbers
ENGINEERING FROM AUG 1-28, 1999	

Amount
65,716.48
Total \$ 65,716.48

County Auditor's Use Only

Checked by _____

Audited by _____

Received _____

Paid _____

[Signature]
Authorized Department Approval

Treasurer's Register Stamp and Number

125631

COUNTY TREASURER
FORT BEND COUNTY
REGISTERED

SEP 28 1999

[Signature]

REQUISITION CERTIFICATE NO. 0015

County Treasurer
Fort Bend County, Texas

Pursuant to Section 3 of the Reimbursement Agreement between Fort Bend Flood Control Water Supply Corporation (the "Corporation") and Fort Bend County Drainage District relating to the payment by the Corporation of its initial costs, such Agreement dated as of January 26, 1999, the County Treasurer of Fort Bend County is directed, upon execution of this certificate, to pay from the Corporation's Big Creek Construction Fund the amount of.

to Jones & Carter \$ 65,716.48
for Engineering from August 1, to August 28, 1999

On behalf of the Corporation, I, the undersigned Representative, do hereby certify as follows

(1) The above described obligation has been incurred and is presently due and payable and has not been paid, or has previously been paid and reimbursement for such payment is appropriate; and that said obligation is a proper charge against the Big Creek Construction Fund,

(2) Payment of such obligation is in conformance with the terms and conditions of the Agreement, and

(3) No Event of Default has occurred and is continuing

Approval of Payment from the Corporation's Big Creek Construction Fund maintained at NationsBank, Richmond Branch in the amount of \$ Sixty-five thousand, seven hundred, sixteen dollars and 48/100

for the purpose(s) described above is evidenced by my manual signature hereon and the approval of the Commissioner's Court of Fort Bend County evidenced hereon

FORT BEND FLOOD CONTROL WATER
SUPPLY CORPORATION

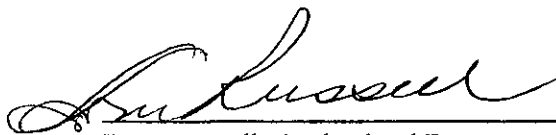

Don Russell, Authorized Representative

Date 9-22-99



JONES & CARTER, INC.
Consulting Engineers

6335 Gulfton, Suite 200
Houston, Texas 77081-1169

713/777-5337
Fax 713/777-5976

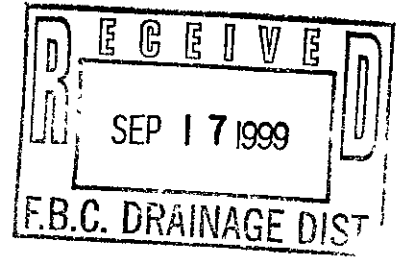

September 15, 1999

Fort Bend Flood Control Water Supply Corporation
Bill Review Committee
c/o Fort Bend County Drainage District
P O Box 1028
Rosenberg, Texas 77471

Re Invoice Summary
Engineering Services
From August 1, 1999 Through August 28, 1999

Dear Mr Council and Mr Zapalac

Enclosed are the Jones & Carter, Inc invoices for August These invoices cover the engineering services for the Big Creek project through August 28, 1999 The total Billing for this month is as follows

Invoicing from August 1, 1999 through August 28, 1999

$\$ 65,216.48 + 500.00 = 65,716.48$
Draw #45092 SAR

If you have any questions regarding our invoices or the current status of the project, please call

Sincerely,

Scott C Saenger, P E

SCS\kae

eng\scs\fb\cws\invoice\99aug16.doc

Approved by

Mr Don Russell

9-22-99
Date

Mr Dan Gerken

9-21-99
Date



JONES & CARTER, INC.

Consulting Engineers

6335 Gulfton Suite 200 Houston, Texas 77081 713/777-5337

INVOICE

Invoice # 45092
August 16, 1979
Page 1

Fort Bend Flood Control WSC
c/o District Data Services, Inc.
8558 Katy Freeway, Suite 119
Houston, TX 77024

Client ID: F5490

Project #: 5062-011

Big Creek Phase II Right-of-Way
Acquisition

SEND COPIES OF INVOICES TO:

- Mr. Paul J. (Jeff) Council
- Mr. Rick Zapalac
- Ms. Gail Kennedy
- Mr. Richard Muller
- Mr. Mark Vogler

In connection with Big Creek Phase II right-of-way acquisition. Includes assistance with obtaining right-of-way for Big Creek.

For Engineering Services through: July 31, 1979

- 001

	Rate -----	Hours -----	Charge -----
Project Engineer	100.00	5 00	500.00
Total Professional Services		\$	500.00 -----
***** INVOICE TOTAL *****		\$	500.00 =====



JONES & CARTER, INC.

Consulting Engineers

6335 Gulfton, Suite 200 Houston, Texas 77081 713/777-5337

AS PER ORIGINAL

INVOICE

Invoice # 4571
September 14, 1999
Page 1

Fort Bend Flood Control (W0)
c/o District Det- Services, Inc.
3503 Katy Freeway, Suite 112
Houston, TX 77024

Client ID: F5470
Project #: 5062-002A Big Creek Phase II
Preliminary Engineering

WHO COPIES OF INVOICES TO:
Mr. Paul J. (Jeff) Connett
Mr. Jack Zapala
Mr. Paul Kennedy
Mr. Richard Muller
Mr. Mark Vogler

In connection with the Preliminary Engineering Report
for Phase II for the Big Creek project.

For Engineering Services through: August 28, 1999

001

Construction Cost	5200000.00	
Percent of Construction Cost	1.25	
Total Fee	\$ 65000.00	
Percent Complete	54.000	
Fee Earned		35750.00
Prorated Fee Billing		-32500.00
Current Fee Total		\$ 3250.00
**** INVOICE TOTAL ****		\$ 3250.00

Accounts Receivable

Invoice Date	Description	Amount	Balance Due
45000 08/16/99	Billing	3250.00	3250.00



JONES & CARTER, INC.

Consulting Engineers

6335 Gulfton, Suite 200 Houston, Texas 77081 713/777-5337

AS PER ORIGINAL

6062 002A
City Creek Phase II
Preliminary Engineering

Invoice # 45413
September 14, 1997
Page 2

TOTAL ACCOUNTS RECEIVABLE 3210.00

BALANCE DUE 4 6500.00



JONES & CARTER, INC.

Consulting Engineers

6335 Gulfon, Suite 200 Houston, Texas 77081 713/777-5337

AS PER ORIGINAL

09/01/79

Invoice # 45417
September 14, 1979
Page 1

Fort Bend Flood Control WCC
c/o District Data Services, Inc.
8558 Katy Freeway, Suite 117
Houston, TX 77024

Client ID: 15420
Project #: 5062-002B Big Creek Phase II Additional Services

SEND COPIES OF INVOICES TO:
Mr. Paul J. (Jeff) Council
Mr. Rick Zapata
Mr. Carl Kennedy
Mr. Richard Muller
Mr. Mark Vogler

In connection with Big Creek Phase II additional ser-
vices, includes coordination of environmental, geo-
technical and other outside consultants.

For Engineering Services through: August 28, 1979

001

	Rate	Hours	Charge
	---	---	----
Engineer II	56.00	9.50	551.00
Total Professional Services		\$	551.00

			Charge
Facsimiles			5.00
Reproduction Services			6.60
Long Distance Telephone			0.72

			20.32
Total Reimbursable Expenses		\$	20.32

JONES & CARTER, INC.
Consulting Engineers

6335 Gulfton, Suite 200 Houston, Texas 77081 713/777-5337

 4062-0021 001
 City Credit Phase II Additional Services

 Invoice # 45417
 September 14, 1999
 Page 2

	Charge
Archeology Investigate	7720.71
Environmental Review	4335.20
	-
	14255.91
 Total Outside Services	 \$ 14255.91
 ***** INVOICE TOTAL *****	 \$ 14827.23

Accounts Receivable

Invoice Date	Description	Amount	Balance Due
45063 08/16/99	Billing	435.58	435.58
	TOTAL ACCOUNTS RECEIVABLE		435.58
	DAI ANCL DUE		\$ 15262.81



JONES & CARTER, INC.

Consulting Engineers

6335 Gulfton, Suite 200 Houston, Texas 77081 713/777-5337

AS PER ORIGINAL

INVOICE

Invoice # 45418
September 14, 1999
Page 1

Fort Bend Flood Control WSC
c/o District Data Services, Inc.
8558 Katy Freeway, Suite 117
Houston, TX 77024

Client ID: 15490
Project #: 5062-003

Big Creek Phase II Topographic Surveying
Channel Cross Sections And Misc Topo

SEND COPIES OF INVOICES TO:
Mr. Paul T. (Jeff) Council
Mr. Rick Zapala
Mr. Carl Kennedy
Mr. Richard Muller
Mr. Matt Vogler

In connection with Big Creek Phase II topographic surveying of channel cross sections and miscellaneous topography.

For Engineering Services through: August 28, 1999

001

	Rate	Hours	Charge
	--	-----	-----
Three Man Surveying Crew	100.00	44.00	4400.00
Two Man Surveying Crew	90.00	26.00	2340.00
Technician 1	50.00	2.00	100.00
		72.00	6840.00
Total Professional Services		\$	6840.00

			Charge

Ex - miles			5.00
Global Positioning Equip.			1600.00
			1605.00
Total Reimbursable Expenses		\$	1605.00



JONES & CARTER, INC.
Consulting Engineers

6335 Gulfton, Suite 200 Houston, Texas 77081 713/777-5337

AS PER ORIGINAL

5062-003
 Big Creek Phase II Topographic Surveying
 Channel Cross Sections and Misc Topo

Invoice # 45410
 September 14, 1999
 Page 2

***** INVOICE TOTAL *****

\$ 8645.00
 =====

Accounts Receivable

Invoice Date	Description	Amount	Balance Due
45084 08/16/99	Billing	15311.80	15311.80
TOTAL ACCOUNTS RECEIVABLE			15311.80
BALANCE DUE			\$ 23956.80



JONES & CARTER, INC.

Consulting Engineers

6335 Gulfton, Suite 200 Houston Texas 77081 713/777-5337

AS PER ORIGINAL

INVOICE #

Invoice # 45416
September 14, 1997
Page 1

Fort Bend Flood Control W3C
c/o District Data Services, Inc.
8559 Katy Freeway, Suite 112
Houston, TX 77024

Client ID: 15420

Project #: 5062-004

Big Creek Phase II Deed Research and
Right-of-Way Definition

SEND COPIES OF INVOICES TO:

- Mr. Paul J. (Jeff) Council
- Mr. Karl Zapata
- Mrs. Carol Kennedy
- Mr. Richard Muller
- Mr. Mark Vogler

In connection with Big Creek Phase II deed research and
right-of-way definition. Includes abstracting right
of way and preparation of deed right-of-way map for
Big Creek.

For Engineering Services through: August 28, 1997

001

	Rate	Hours	Charge
Project Engineer	100.00	1.00	100.00
Engineer I	55.00	28.00	1540.00
Engineering Assistant	30.00	1.50	45.00
CAD Operator V	57.00	70.50	4018.50
Three-Man Surveying Crew	100.00	18.50	1850.00
Two-Man Surveying Crew	90.00	12.00	1080.00
Surveying Manager	100.00	15.00	1500.00
Technician I	50.00	132.00	6600.00
Reg. Prof. Land Surveyor	75.00	5.50	412.50
		398.00	17,446.00
Total Professional Services		\$	17,446.00



JONES & CARTER, INC.

Consulting Engineers

6335 Gulfton, Suite 200 Houston, Texas 77081 713/777-5337

AS PER ORIGINAL

5062-004 001
Big Creek Phase II Deed Research and
Right-of-Way Definition

Invoice # 45417
September 14, 1997
Page 2

	Charge
Facsimiles	5.00
Global Positioning Equip.	900.00
Computer Hours	780.00
Research Services	71.07

	1756.07
Total Reimbursable Expenses	\$ 1756.07

***** INVOICE TOTAL *****	\$ 19102.07
	=====

Accounts Receivable

Invoice Date	Description	Amount	Balance Due
45085 09/16/97	Billing	1002.15	1002.15

	TOTAL ACCOUNTS RECEIVABLE		1002.15

		BALANCE DUE	\$ 20104.22

JONES & CARTER, INC.
Consulting Engineers

6335 Gulfton, Suite 200 Houston, Texas 77081 713/777-5337

INVOICE

 Invoice # 45420
 September 14, 1999
 Page 1

 Fort Bend Flood Control WSC
 c/o District Data Services, Inc.
 8958 Katy Freeway, Suite 119
 Houston, TX 77024

 Client ID: 15490
 Project #: 5062-005

 Big Creek Phase II Right-of-Way
 Surveying and Preparation of Maps

SEND COPIES OF INVOICES TO:

 Mr. Paul J. (Jeff) Council
 Mr. Rick Zapala
 Ms. Gail Kennedy
 Mr. Richard Muller
 Mr. Mark Vogler

In connection with Big Creek Phase II right-of-way surveying and preparation of right-of-way maps. Includes surveying of Big Creek right-of-way; review of right-of-way determination; surveying control for right-of-way and other right-of-way issues.

For Engineering Services through: August 28, 1999

001

	Rate	Hours	Charge
CAD Operator V	57.00	50.00	2850.00
Total Professional Services			2850.00
			Charge
Computer Hours			525.00
Plotter (Color Bond/Std)			60.00
Plotter (Color Bond/Med)			210.00
Plotter (Bond/Std/Med)			84.00
Plotter (Bond/Std/Lrg)			84.00
			963.00
Total Reimbursable Expenses			963.00



JONES & CARTER, INC.

Consulting Engineers

6335 Gulfton, Suite 200 Houston, Texas 77081 713/777-5337

AS PER ORIGINAL

5062-005
Big Creek Phase II Right-of-Way
Surveying and Preparation of Maps

Invoice # 45420
September 14, 1999
Page 2

***** INVOICE TOTAL *****

\$ 3013.00
:: =====

Accounts Receivable

Invoice Date	Description	Amount	Balance Due
45006 08/16/99	Billing	6257.00	6257.00
TOTAL ACCOUNTS RECEIVABLE			6257.00
BALANCE DUE			\$ 10070.00



JONES & CARTER, INC.

Consulting Engineers

6335 Gulfon Suite 200 Houston, Texas 77081 713/777-5337

AS PER ORIGINAL

INVOICE

Invoice # 45421
September 14, 1979
Page 1

Fort Bend Flood Control WSC
c/o District Data Services, Inc.
8558 Katy Freeway, Suite 117
Houston, TX 77024

Client ID: 15490

Project #: 5062-006

Big Creek Phase II Bridge and Structure
Surveying

CLIENT COPIES OF INVOICES TO:

- Mr. Paul J. (Jeff) Council
- Mr. Rick Zapata
- Mr. Gail Kennedy
- Mr. Richard Muller
- Mr. Paul Vogler

In connection with Big Creek Phase II topographic surveying for pipelines, bridges and other structures along Big Creek. Includes topographic control and locating and surveying of structures crossing Big Creek.

For Engineering Services through: August 28, 1979

001

	Rate	Hours	Charge
Project Engineer	100.00	1.00	100.00
CAD Operator V	57.00	11.00	627.00
		12.00	727.00
Total Professional Services		\$	727.00
			Charge
Computer Hours			50.00
Total Reimbursable Expenses		\$	777.00



JONES & CARTER, INC.

Consulting Engineers

6335 Gulfton, Suite 200 Houston Texas 77081 713/777-5337

AS PER ORIGINAL

5062-006
Big Creek Phase II Bridge and Structure
Surveying

Invoice # 45421
September 14, 1999
Page 2

***** INVOICE TOTAL *****

\$ 757.00
=====

Accounts Receivable

Invoice Date	Description	Amount	Balance Due
4508/ 09/16/99	Billing	600.00	600.00
TOTAL ACCOUNTS RECEIVABLE			600.00
BALANCE DUE			\$ 1357.00



JONES & CARTER, INC.

Consulting Engineers

6335 Gulfon, Suite 200 Houston, Texas 77081 713/777-5337

AS PER ORIGINAL

INVOICE

Invoice # 4542C
September 14, 1979
Page 1

Fort Bend Flood Control WSC
c/o District Data Services, Inc.
8550 Katy Freeway, Suite 117
Houston, TX 77024

Client ID: F5490
Project #: 5062-007

Big Creek Phase II Hydraulics and
Hydrology Evaluation

SEND COPIES OF INVOICES TO:
Mr. Paul J. (Jeff) Council
Mr. Rick Zapala
Ms. Gail Kennedy
Mr. Richard Muller
Mr. Mark Vogler

In connection with Big Creek Phase II hydraulics and hydrology evaluation of bridges and structures and HEC modeling of bridges and structures. Includes hydraulic evaluation of bridges and updating/revising modeling to reflect current structures.

For Engineering Services through: August 20, 1979

001

	Rate	Hours	Charge
Project Engineer	100.00	5.00	500.00
Engineer II	58.00	1.50	87.00
		6.50	587.00
Total Professional Services		6	587.00
***** INVOICE TOTAL *****		6	587.00

Accounts Receivable

Invoice No.	Description	Amount	Balance Due
-------------	-------------	--------	-------------



JONES & CARTER, INC.

Consulting Engineers

6335 Gulfton, Suite 200 Houston Texas 77081 713/777-5337

AS PER ORIGINAL

5042-007
Big Creek Phase II Hydraulics and
Hydrology Evaluation

Invoice # 45422
September 14, 1999
Page 2

45068	08/16/99	Billing	1200.00	1200.00
			TOTAL ACCOUNTS RECEIVABLE	1200.00
			BALANCE DUE	\$ 1707.00



JONES & CARTER, INC.

Consulting Engineers

6335 Gulfton, Suite 200 Houston, Texas 77081 713/777-5337

INVOICE

Invoice # 45473
September 14, 1999
Page 1

Fort Bend Flood Control WSC
c/o District Data Services, Inc.
8508 Katy Freeway, Suite 119
Houston, TX 77024

Client ID: P499

Project #: 5062-008

Big Creek Phase II Hydraulics and
Hydrology Update Model

THIRD COPIES OF INVOICES TO:

- Mr. Paul J. (Jeff) Council
- Mr. Rick Zapala
- Ms. Gail Kennedy
- Mr. Richard Muller
- Mr. Matt Vogler

In connection with Big Creek Phase II hydraulics and hydrology. Includes updating model with floodplain and floodway definition with updated topography.

For Engineering Services through: August 28, 1999

- 001

	Rate	Hours	Charge
Project Engineer	100.00	9.00	900.00
Engineer II	58.00	45.50	2639.00
CAD Operator V	57.00	20.00	1140.00
		74.50	4679.00
Total Professional Services		\$	4679.00
			Charge
Computer Hours			375.00
Total Reimbursable Expenses		\$	375.00
***** INVOICE TOTAL *****		\$	5054.00



JONES & CARTER, INC.

Consulting Engineers

6335 Gulfon, Suite 200 Houston, Texas 77081 713/777-5337

AS PER ORIGINAL

5062-00E
Big Creek Phase II Hydraulics and
Hydrology Update Model

Invoice # 45423
September 14, 1999
Page 2

Accounts Receivable

Invoice Date	Description	Amount	Balance Due
45089 08/16/99	Billing	14993.70	14993.70
TOTAL ACCOUNTS RECEIVABLE			14993.70
BALANCE DUE			\$ 20047.70



JONES & CARTER, INC.

Consulting Engineers

6335 Gulfon, Suite 200 Houston Texas 77081 713/777 5337

AS PER ORIGINAL

INV0101

Invoice # 45424
September 14, 1997
Page 1

Fort Bend Flood Control WCC
c/o District Data Services, Inc.
8550 Katy Freeway, Suite 112
Houston, TX 77024

Client ID: 15490

Project #: 5062-009

Big Creek Phase II Hydraulics and
Hydrology Sizing of Structures & Bridges

- SEND COPIES OF INVOICES TO:
- Mr. Paul J. (Jeff) Council
- Mr. Rich Zapalac
- Mr. Carl Kennedy
- Mr. Richard Muller
- Mr. Mark Vogler

In connection with Big Creek Phase II hydraulics and hydrology. Includes preliminary sizing of structures, bridges, and control structures; and hydraulic requirements for Phase II Big Creek.

For Engineering Services through: August 28, 1997

001

	Rate	Hours	Charge
Project Engineer	100.00	13.00	1300.00
Engineer II	58.00	22.50	1305.00
Engineer I	55.00	88.00	4840.00
		123.50	7445.00
Total Professional Services		\$	7445.00

	Charge
Film / Film Processing	5.17
Computer Hours	600.00
Long Distance Telephone	1.01
	606.18



JONES & CARTER, INC.

Consulting Engineers

6335 Gulfton, Suite 200 Houston, Texas 77081 713/777-5337

4062-009 001
 Big Creek Phase II Hydraulics and
 Hydrology Sizing of Structures & Bridges

Invoice # 45429
 September 14, 1999
 Page 2

Total Reimbursable Expenses \$ 606.13

***** INVOICE TOTAL ***** \$ 8051.13

Accounts Receivable

Invoice Date	Description	Amount	Balance Due
45090 08/16/99	Billing	4183.20	4183.20
TOTAL ACCOUNTS RECEIVABLE			4183.20
BALANCE DUE			\$ 12254.33



JONES & CARTER, INC.

Consulting Engineers

6335 Gulfton, Suite 200 Houston, Texas 77081 713/777-5337

AS PER ORIGINAL

INVOICE

Invoice # 45425
September 14, 1979
Page 1

Fort Bend Flood Control WSO
Los District Data Services, Inc.
3553 Katy Freeway, Suite 112
Houston, TX 77054

Client ID: 15490
Project #: 5062-010

Big Creek Phase II Overall Project
Sequencing and Phasing

SEND COPIES OF INVOICES TO:
Mr. Paul J. (Jeff) Council
Mr. Karl Zapala
Ms. Gail Kennedy
Mr. Richard Hoffer
Mr. Earl Vogler

In connection with Big Creek Phase II overall project sequencing and phasing. Includes coordination with outside agencies; submittals for agency approval; coordination of Phase II activities; and determination of sequences for Phase II and future phase.

For Engineering Services Through: August 28, 1979

- 001

	Rate	Hours	Charge
Officer, Principal	140.00	2.00	280.00
Project Engineer	100.00	3.50	350.00
		10.50	1130.00
Total Professional Services		\$	1130.00
**** INVOICE TOTAL ****		\$	1130.00

Accounts Receivable

Invoice Date	Description	Amount	Balance Due
--------------	-------------	--------	-------------



JONES & CARTER, INC

Consulting Engineers

6335 Gulfton Suite 200 Houston, Texas 77081 713/777-5337

AS PER ORIGINAL

5067 010
Ing Creek Phase II Overall Project
Sequencing and Phasing

Invoice # 45425
September 14, 1999
Page 2

45091 09/14/99 Billing 500.00 500.00

TOTAL ACCOUNTS RECEIVABLE 500.00

LIABANCE DUE 4 1630.00

INVOICE TRANSMITTAL

12-Digit Distribution 265-006-2640-4010
Vendor Number 467942368
Purchase Order Number (S)
REQ CERT 0016

Vendor Name RICK ZAPALAC		
Address P O BOX 231		
City ROSENBERG		
State TX	Zip Code 77471	Date 9-28-99

Description	Invoice Numbers
DIRECTORS FEE FOR 1 MEETING	

Amount
100.00
Total \$ 100.00

County Auditor's Use Only	
Check Type	
Audited By	
Received	
Paid	

[Signature]
Authorized Department Approval

Treasurer's Register Stamp and Number
125632
COUNTY TREASURER FORT BEND COUNTY REGISTERED
SEP 28 1999
<i>[Signature]</i>

REQUISITION CERTIFICATE NO. 0016

County Treasurer
Fort Bend County, Texas

Pursuant to Section 3 of the Reimbursement Agreement between Fort Bend Flood Control Water Supply Corporation (the "Corporation") and Fort Bend County Drainage District relating to the payment by the Corporation of its initial costs, such Agreement dated as of January 26, 1999, the County Treasurer of Fort Bend County is directed, upon execution of this certificate, to pay from the Corporation's Big Creek Construction Fund the amount of

to Rick Zapalac \$ 100.00
for Directors fees for attending 1 meeting @ \$ 100.00 per meeting.

On behalf of the Corporation, I, the undersigned Representative, do hereby certify as follows.

(1) The above described obligation has been incurred and is presently due and payable and has not been paid, or has previously been paid and reimbursement for such payment is appropriate, and that said obligation is a proper charge against the Big Creek Construction Fund,

(2) Payment of such obligation is in conformance with the terms and conditions of the Agreement, and

(3) No Event of Default has occurred and is continuing

Approval of Payment from the Corporation's Big Creek Construction Fund maintained at NationsBank, Richmond Branch in the amount of \$ One hundred dollars and no/100

for the purpose(s) described above is evidenced by my manual signature hereon and the approval of the Commissioner's Court of Fort Bend County evidenced hereon

FORT BEND FLOOD CONTROL WATER
SUPPLY CORPORATION



Don Russell, Authorized Representative

Date 9-22-99

INVOICE TRANSMITTAL

AS PER ORIGINAL

12 Digit Distribution 264-006-2640-4010
Vendor Number 741792255
Purchase Order Number (s) REQ CERT 1410

Vendor Name LJA ENGINEERING & SURVEYING		
Address 2929 BRIARPARK DR SUITE 500		
City HOUSTON		
State TX	Zip Code 77042-3703	Date 9-28-99

Description / Invoice Numbers
ENGINEERING FEES FOR Aug 1-27, 1999

Amount
12,332.21
Total \$ 12,332.21

County Auditor's Use Only	
Credit Type	
Audited By	
Reviewed	
Paid	

Authorized Department Approval

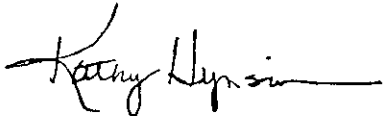
Treasurer's Register Stamp and Number
125633
COUNTY TREASURER FORT BEND COUNTY REGISTERED
SEP 28 1999

REQUISITION CERTIFICATE NO. 1410

County Treasurer
Fort Bend County, Texas

Pursuant to Section 2 05 of the Agreement between Fort Bend Flood Control Water Supply Corporation (the "Corporation") and Fort Bend County, Texas and Fort Bend County Drainage District relating to the issuance by the Corporation of its \$20,325,000 Revenue Bonds, Series 1989, \$6,850,000 Revenue Bonds, Series 1995 and \$14,060,000 Revenue Refunding Bonds, Series 1999, such Agreement dated as of April 1, 1989, the First Supplement to such Agreement dated April 18, 1995 and the Second Supplemental Agreement dated June 15, 1999, (the "Agreement"), the County Treasurer of Fort Bend County is directed, upon execution of this certificate, to pay from the Corporation's Construction Fund the amount of

to LJA Land Development \$ 12,332 21
for Engineering fees for the period August 1 to August 27, 1999

On behalf of the Corporation, I, the undersigned Representative, do hereby certify as follows

- (1) The above described obligation has been incurred and is presently due and payable and has not been paid, or has previously been paid and reimbursement for such payment is appropriate, and that said obligation is a proper charge against the Construction Fund,
- (2) Payment of such obligation is in conformance with restrictions on use of proceeds set forth in Section 7 02 of the Agreement, and
- (3) No Event of Default has occurred and is continuing

Approval of Payment from the Corporation's Construction Fund maintained at NationsBank, Richmond Branch in the amount of \$ Twelve thousand, three hundred, thirty-two dollars and 21/100

for the purpose(s) described above is evidenced by my manual signature hereon and the approval of the Commissioner's Court of Fort Bend County evidenced hereon

FORT BEND FLOOD CONTROL WATER
SUPPLY CORPORATION

Don Russell, Authorized Representative

Date 9-22-99

LJA Engineering & Surveying, Inc.



2929 Briarpark Drive
Suite 500
Houston, Texas 77042-3703

Phone 713 953 5200
Fax 713 953 5026

September 17, 1999

Mr. Daniel E. Gerken, P.E.
Fort Bend County Drainage District
P O Box 1028
Rosenberg, Texas 77471

Re. Billing Summary for Engineering Services
Fort Bend Flood Control Water Supply Corporation
Flood Control Improvements for Stafford Run, Phase II

Dear Dan

Please find enclosed the invoices for the engineering services performed by *LJA* Engineering & Surveying, Inc., indicating fees earned for the period of August 1, 1999 through August 27, 1999. The total amount due is \$12,332.21.

Please review this material and call if you have any questions.

Very truly yours,



Omar Escobar
Project Manager

OE/nh

- c. Mr. Mark Vogler, Fort Bend County Drainage District
Board of Directors, FBFCWSC
- Mr. Richard Muller, Vinson & Elkins
- Ms. Gayle G. Kennedy, FBFCWSC Administrative Assistant
- Mr. Skip Stanley, District Data Services, Inc.

File 0414-0201 (2 0)

Enclosures

LJA Engineering & Surveying, Inc.



2929 Briarpark Drive
Suite 500
Houston, Texas 77042-3703

Phone 713 953 5200
Fax 713 953 5026
www.ljaengineering.com

Invoice To:

Ft Bend Flood Control Water Supply Corp.

Attn Richard L Muller, Jr
c/o Vinson & Elkins
2800 First City Tower, 1001 Fannin
Houston, TX 77002

Date September 15, 1999
Invoice No 9905228
Project No 0414-0201
Project Manager Escobar, Omar

Compensation: Time & Materials

Terms Net 30

Progress Billing

For professional services rendered for the period August 1, 1999 to August 27, 1999 in conjunction with Stafford Run Ph II

Engineering Services

Phase No	Description	Labor To Date	Previously Invoiced	Labor This Invoice
002	Boundary Survey	11,411 53	11,049 01	362 52
007	Design Phase Services	62,361 15	51,531 68	10,829 50
044	District Coordination	13,383 28	12,356 62	1,026 66
				12,218 68

Reimbursable Expenses

Mileage - Direct (Reimb)	\$31 00
Outside Repro - Direct (Reimb)	\$82 53
	\$113 53

Total Amount Due

\$12,332.21

Approved By

Escobar, Omar

Remit To LJA Engineering & Surveying Inc , 2929 Briarpark, Ste 500, Houston, TX 77042-3703

Pre-Billing Worksheet

LJA Engineering & Surveying Inc

Page 1

Stafford Run Ph II

Project ID: 0414-0201

Ft Bend Flood Control Water Supply Corp

Invoice #: 9905228

c/o Vinson & Elkins

Period: 08/01/1999 - 08/27/1999

2800 First City Tower, 1001 Fannin

Project Type

Houston, TX 77002

Invoice Type: TM2

Attn: Richard L. Muller, Jr

Principal:

Project Manager: 015 Escobar, Omar

Bill Schedule: SURVEY

A/E Services

Description	Title	Date	Rate	Hold Hrs	Actual Hrs	Bill Hrs	Write Up/ Write Down	Billable Amount	Adjustment
Boundary Survey									
Escobar, Omar	Technical Supervisor	08/06/1999	90.63	0.00	4.00	4.00	\$0.00	\$362.52	
Phase Total				0.00	4.00	4.00	\$0.00	\$362.52	
Design Phase Services									
Escobar, Omar	Technical Supervisor	08/20/1999	90.63	0.00	5.00	5.00	\$0.00	\$453.16	
Escobar, Omar	Technical Supervisor	08/27/1999	90.63	0.00	5.00	5.00	\$0.00	\$453.16	
Casas, Javier	Assistant PM	08/13/1999	76.53	0.00	22.00	22.00	\$0.00	\$1,683.66	
Casas, Javier	Assistant PM	08/13/1999	76.53	0.00	7.50	7.50	\$0.00	\$573.98	
Casas, Javier	Assistant PM	08/20/1999	76.53	0.00	7.00	7.00	\$0.00	\$535.71	
Casas, Javier	Assistant PM	08/20/1999	76.53	0.00	1.00	1.00	\$0.00	\$76.53	
Casas, Javier	Assistant PM	08/20/1999	76.53	0.00	3.00	3.00	\$0.00	\$229.59	
Casas, Javier	Assistant PM	08/27/1999	76.53	0.00	3.00	3.00	\$0.00	\$229.59	
Nickell, Carl									
Dean	Staff Technician III	08/06/1999	56.57	0.00	30.00	30.00	\$0.00	\$1,697.18	
Nickell, Carl									
Dean	Staff Technician III	08/13/1999	56.57	0.00	14.00	14.00	\$0.00	\$792.02	
Nickell, Carl									
Dean	Staff Technician III	08/20/1999	56.57	0.00	20.00	20.00	\$0.00	\$1,131.46	
Nickell, Carl									
Dean	Staff Technician III	08/27/1999	56.57	0.00	6.00	6.00	\$0.00	\$339.44	
Culver, George	Cadd Tech I	08/27/1999	52.17	0.00	3.00	3.00	\$0.00	\$156.52	
Cooper, Marie	Admin Support IV	08/13/1999	42.86	0.00	1.50	1.50	\$0.00	\$64.29	
Cooper, Marie	Admin Support IV	08/20/1999	42.86	0.00	2.00	2.00	\$0.00	\$85.72	
Cooper, Marie	Admin Support IV	08/20/1999	42.86	0.00	1.00	1.00	\$0.00	\$42.86	
Luna, Jose	Cadd Tech	08/20/1999	42.20	0.00	4.00	4.00	\$0.00	\$168.80	

Description	Title	Date	Rate	Hold Hrs	Actual Hrs	Bill Hrs	Write Up/ Write Down	Billable Amount	Adjustment
Luna, Jose	Cadd Tech	08/06/1999	39 18	0 00	30 00	30 00	\$0 00	\$1,175 46	
Luna, Jose	Cadd Tech	08/13/1999	39 18	0 00	23 00	23 00	\$0 00	\$901 19	
Luna, Jose	Cadd Tech	08/13/1999	39 18	0 00	1 00	1 00	\$0 00	\$39 18	
Phase Total				0 00	189 00	189 00	\$0 00	\$10,829 50	
District Coordination									
Escobar, Omar	Technical Supervisor	08/20/1999	90 63	0 00	4 00	4 00	\$0 00	\$362 52	
Escobar, Omar	Technical Supervisor	08/27/1999	90 63	0 00	7 00	7 00	\$0 00	\$634 42	
Cazares, Sara	Admin Support VI	08/20/1999	29 72	0 00	0 50	0 50	\$0 00	\$14 86	
Cazares, Sara	Admin Support VI	08/20/1999	29 72	0 00	0 50	0 50	\$0 00	\$14 86	
Phase Total				0 00	12 00	12 00	\$0 00	\$1,026 66	
Project Total				0 00	205 00	205 00	\$0 00	\$12,218 68	

Consultant Expenses

Out-of-Pocket Expenses

	Date	Hold Q'ty	Hold Cost	Bill Q'ty	(Billable) Cost	Write Up /Down	Billable Amount	Adjustment
Crystal Graphics, Inc	02/24/1999	0 00	0 00	1 00	8 12	\$-8 93	\$0 00	
Crystal Graphics, Inc	08/06/1999	0 00	0 00	1 00	12 28	\$0 00	\$13 51	
Crystal Graphics, Inc	08/16/1999	0 00	0 00	1 00	25 46	\$0 00	\$28 01	
Crystal Graphics, Inc	08/24/1999	0 00	0 00	1 00	24 55	\$0 00	\$27 01	
Crystal Graphics, Inc	08/25/1999	0 00	0 00	1 00	12 73	\$0 00	\$14 00	
Escobar, Omar	02/18/1999	0 00	0 00	60 00	18 60	\$-20 46	\$0 00	
Escobar, Omar	02/22/1999	0 00	0 00	60 00	18 60	\$-18 60	\$0 00	
Escobar, Omar	02/22/1999	0 00	0 00	1 00	26 94	\$-29 63	\$0 00	
Escobar, Omar	02/24/1999	0 00	0 00	30 00	9 30	\$-9 30	\$0 00	
Escobar, Omar	08/23/1999	0 00	0 00	50 00	15 50	\$0 00	\$15 50	
Escobar, Omar	08/25/1999	0 00	0 00	20 00	6 20	\$0 00	\$6 20	
Escobar, Omar	08/25/1999	0 00	0 00	30 00	9 30	\$0 00	\$9 30	
Omar Escobar	03/26/1999	0 00	0 00	30 00	9 30	\$-9 30	\$0 00	
Omar Escobar	03/26/1999	0 00	0 00	50 00	15 50	\$-15 50	\$0 00	
Omar Escobar	03/26/1999	0 00	0 00	1 00	24 70	\$-27 17	\$0 00	
Omar Escobar	03/26/1999	0 00	0 00	30 00	9 30	\$-9 30	\$0 00	
			0 00		246 38	\$-148 19	\$113 53	

Total A/E Services	\$12,218 68
Total Consultant Expenses	\$0 00
Total Out-of-Pocket Expenses	\$113 53

Invoice Total **\$12,332 21**

Project Summary

	Contract	Previous Billed	Current Period	Contract Left
A/E Services	0 00	78,051 69	12,218 68	-90,270 37
Consultants	0 00	0 00	0 00	0 00
Out-of-Pocket	0 00	10,212 77	113 53	-10,326 30
	0 00	88,264 46	12,332 21	-100,596 67

LJA Invoicing breakdown thru Aug 27, 1999

Invoice No	Invoice date	District 044	Hydraulics 035	Design 007	Survey 002	Const 010	Reimb	Totals
9703004	10/16/98	\$1,180 89	\$1,922 07					\$3,102 96
9703142	11/20/98	\$1,700 89	\$342 45	\$400 09			\$49 78	\$2,493 21
9703349	12/10/98	\$266 54		\$2,199 92			\$748 51	\$3,214 97
9903474	01/15/99	\$1,078 97		\$398 88			\$1,429 91	\$2,907 76
9903762	02/12/99	\$934 49		\$7,745 89	\$814 20		\$87 22	\$9,581 80
9903888	03/12/99			\$9,284 76			\$2,664 82	\$11,949 58
9904017	04/09/99	\$906 31		\$7,622 95		\$430 25	\$600 88	\$9,560 39
9904226	05/14/99	\$996 94		\$7,290 03		\$13 56	\$1,808 55	\$10,109 08
9904421	06/14/99	\$1,192 29		\$4,695 26	\$5,546.98		\$201 83	\$11,636 36
9904639	07/19/99	\$3,057 76	\$406 05	\$2,987 66	\$1,637.47		\$1,953 05	\$10,041.99
9904997	08/13/99	\$1,041 52		\$8,906.28	\$3,050.35		\$668 22	\$13,666 37
9905228	09/15/99	\$1,026 66		\$10,829 50	\$362 52		\$113 53	\$12,332 21
Totals		\$13,383.26	\$2,670 57	\$62,361 22	\$11,411 52	\$443.81	\$10,326 30	\$100,596 68

Budget breakdown T&M \$5,000 00 \$70,750 00 \$10,000 00 \$18,000 00 T&M \$103,750 00

Balance \$2,329 43 \$8,388 78 (\$1,411.52) \$17,556 19 \$26,862 88

Task Descriptions

044 District Coordination Effort expended with Bill review meetings, Monthly meetings and preparation of the same, and any other requests by the County, the Board of Directors or its consultants not specific to the current design plans

035 Hydraulics Effort expended on the hydraulic modeling as required by design and as-builts

007 Design Effort expended for the production and approval of the construction plans including the preparation of the bid package with engineering estimates

002 Survey Labor for the right-of-way and detailed topography required for design

010 Construction Labor expended for the bidding, contract negotiations, project representation and construction administration of the contract

INVOICE TRANSMITTAL

2 Orig. Distribution
264-006-2640-4010
Vendor Number
941687665
Purchase Order Number(s)
REQ CERT 1412

Vendor Name		
BANK OF AMERICA		
ATTN: Jill Burtchaell, CCM		
Address	P.O. BOX 2518	
COMM. BANKING 11		
City	HOUSTON	
State	Zip Code	Date
TX	77252-2518	9-28-99

Description / Invoice Numbers
ACCOUNT ANALYSIS FOR AUGUST 1999

Amount
82.98
Total \$ 82.98

County Auditor's Use Only

Check Type _____

Audited by _____

Reviewed _____

Paid _____



Authorized Department Approve

Treasurer's Register Stamp and Number

125634

COUNTY TREASURER
FORT BEND COUNTY
REGISTERED

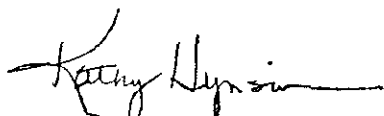
SEP 28 1999



REQUISITION CERTIFICATE NO. 1412

County Treasurer
Fort Bend County, Texas

Pursuant to Section 2 05 of the Agreement between Fort Bend Flood Control Water Supply Corporation (the "Corporation") and Fort Bend County, Texas and Fort Bend County Drainage District relating to the issuance by the Corporation of its \$20,325,000 Revenue Bonds, Series 1989, \$6,850,000 Revenue Bonds, Series 1995 and \$14,060,000 Revenue Refunding Bonds, Series 1999, such Agreement dated as of April 1, 1989, the First Supplement to such Agreement dated April 18, 1995 and the Second Supplement to such Agreement dated June 15, 1999 (the "Agreement"), the County Treasurer of Fort Bend County is directed, upon execution of this certificate, to pay from the Corporation's Construction Fund the amount of

to Bank of America \$ 82.98
for Account Analysis for August, 1999

On behalf of the Corporation, I, the undersigned Representative, do hereby certify as follows

(1) The above described obligation has been incurred and is presently due and payable and has not been paid, or has previously been paid and reimbursement for such payment is appropriate, and that said obligation is a proper charge against the Construction Fund,

(2) Payment of such obligation is in conformance with restrictions on use of proceeds set forth in Section 7 02 of the Agreement, and

(3) No Event of Default has occurred and is continuing

Approval of Payment from the Corporation's Construction Fund maintained at NationsBank, Richmond Branch in the amount of \$ Eighty-two dollars and 98/100

for the purpose(s) described above is evidenced by my manual signature hereon and the approval of the Commissioner's Court of Fort Bend County evidenced hereon

**FORT BEND FLOOD CONTROL WATER
SUPPLY CORPORATION**



Don Russell, Authorized Representative

Date 9-22-99

Bank of America



BANK OF AMERICA, N.A.
P O BOX 830175 ACCT ANALYSIS
DALLAS, TX 75283-0175

ANALYSIS INVOICE

Member FDIC

PUBLIC FUNDS INTEREST CKG	01	0080 2900 1913
BANK AND COST CENTER NUMBER	099	0003049
DATE PREPARED	09-07-99	
MONTH ENDING	08-31-99	
MONTHLY SETTLEMENT	08-31-99	
SETTLEMENT & ACCOUNT TYPE	INVOICE	562
OFFICER NUMBER	6468	
PAGE	1 OF	1



FORT BEND FLOOD CONTROL
WATER SUPPLY CORP
ATTN TREASURER
PO BOX 1202
RICHMOND TX 77469-1202



INVOICE AND PAYMENT INFORMATION IS LISTED BELOW

INVOICE NUMBER	INVOICE DATE	INVOICE AMOUNT/TAX	PAYMENT(S)/ADJUSTMENT(S)	PMT/ADJ DATE	OUTSTANDING BALANCE
99060000692	07-08-99	\$ 33.70	\$ 33.70 PMT	08-25-99	\$.00
99070000421	08-06-99	101.71			101.71
99080000398	09-07-99	82.98			82.98
					<u>\$ 184.69</u>

TOTAL AMOUNT DUE (US DOLLARS). \$ 184.69

DETACH THIS PORTION AND REMIT TO ADDRESS SHOWN BELOW

ANALYSIS INVOICE

BANK OF AMERICA, N.A.
P.O. BOX 830175 ACCT ANALYSIS
DALLAS, TX 75283-0175

ACCOUNT NUMBER 01 0080 2900 1913
BANK AND COST CENTER NUMBER 099 0003049

TOTAL AMOUNT DUE (U.S. DOLLARS): \$ 184.69

AMOUNT ENCLOSED: \$ _____

APPLY PAYMENTS TO THE FOLLOWING INVOICES:
INVOICE NUMBER AND AMOUNT AMOUNT

99070000421	\$ 101.71	\$ _____
99080000398	\$ 82.98	\$ _____

MAIL PAYMENT TO:

BANK OF AMERICA
P O BOX 550588
ACCOUNT ANALYSIS
TAMPA, FL 33655-0588

TOTAL PAYMENT DUE 30 DAYS FROM INVOICE DATE
THANK YOU FOR BANKING WITH BANK OF AMERICA

Bank of America



BANK OF AMERICA, N.A.
 P O. BOX 830175 ACCT ANALYSIS
 DALLAS, TX 75283-0175

ANALYSIS STATEMENT

Member FDIC

PUBLIC FUNDS INTEREST CKG 01 0080 2900 1913
 BANK AND COST CENTER NUMBER 099 0003049

DATE PREPARED 09-07-99

MONTH ENDING 08-31-99
 MONTHLY SETTLEMENT 08-31-99
 SETTLEMENT & ACCOUNT TYPE INVOICE 562
 OFFICER NUMBER 6468
 PAGE 1 OF 1

FORT BEND FLOOD CONTROL
 WATER SUPPLY CORP
 ATTN TREASURER
 PO BOX 1202
 RICHMOND TX 77469-1202

BALANCE SUMMARY

AVG POSITIVE LEDGER BALANCE	\$	16,130.47
<hr/>		
AVG LEDGER BALANCE		16,130.44
LESS AVG FLOAT		.00
<hr/>		
AVG COLLECTED BALANCE		16,130.44
AVG NEGATIVE COLL BALANCE		.02
<hr/>		
AVG POSITIVE COLL BALANCE		16,130.47
LESS RESERVES 00%		.00
<hr/>		
AVAIL BAL FOR EARNINGS CREDIT		16,130.47
AVAILABLE BALANCE REQUIRED		.00
<hr/>		
NET AVAILABLE BALANCE		16,130.47

EARNINGS CREDIT SUMMARY

AVAIL BAL FOR EARNINGS CREDIT	\$	16,130.47
<hr/>		
EARNINGS ON AVAILABLE BALANCE		.00
LESS TOTAL SERVICE CHARGES		82.98
<hr/>		
DEFICIT		82.98
<hr/>		
PERIOD TO DATE DEFICIT		82.98
<hr/>		
CURRENT PERIOD SERVICE CHARGE	\$	82.98
<hr/>		

INVOICE# 99080000398 IS ATTACHED
 FOR SERVICE CHARGES.

SERVICE	NUMBER OF UNITS	UNIT PRICE	SERVICE CHARGE	BALANCE REQUIRED
DEPOSITORY SERVICES				
ACCOUNT MAINTENANCE	1	10.0000	10.00	0 00
DEBITS	16	.0800	1 28	0 00
CREDITS	10	.3000	3.00	0.00
ELECTRONIC DEBIT	8	.1500	1.20	0.00
WIRE TRANSFER				
WIRE-INCOMING	5	6.0000	30.00	0.00
WIRE ADVICE-MAIL	11	5000	5.50	0 00
PC WIRE-BOOK REPETITIVE	1	2 0000	2.00	0.00
PC WIRE-OUT REPETITIVE	5	6.0000	30 00	0 00
<hr/>				
TOTAL SERVICE CHARGES			82 98	0 00

INVOICE TRANSMITTAL

AS PER ORIGINAL

12 Digit Distribution 264-006-2640-4010
Vendor Number 441560229
Purchase Order Number(s) REQ CERT 1409

Vendor Name GAYLE G. KENNEDY		
Address 3910 SOUTHWESTERN		
City HOUSTON		
State TX	Zip Code 77005	Date 9-28-99

Description/Invoice Numbers
SERVICES AND EXPENSES FOR SEPTEMBER 1999

Amount
362.07
Total \$ 362.07

County Auditor's Use Only
Credit Type
Audited by
Received
Paid

Authorized Department Approval

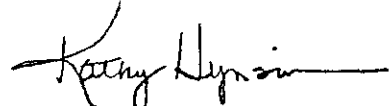
Treasurer's Register Stamp and Number
125635
COUNTY TREASURER FORT BEND COUNTY REGISTERED
SEP 28 1999

REQUISITION CERTIFICATE NO. 1409

County Treasurer
Fort Bend County, Texas

Pursuant to Section 2 05 of the Agreement between Fort Bend Flood Control Water Supply Corporation (the "Corporation") and Fort Bend County, Texas and Fort Bend County Drainage District relating to the issuance by the Corporation of its \$20,325,000 Revenue Bonds, Series 1989, \$6,850,000 Revenue Bonds, Series 1995 and \$14,060,000 Revenue Refunding Bonds, Series 1999, such Agreement dated as of April 1, 1989, the First Supplement to such Agreement dated April 18, 1995 and the Second Supplement to such Agreement dated June 15, 1999 (the "Agreement"), the County Treasurer of Fort Bend County is directed, upon execution of this certificate, to pay from the Corporation's Construction Fund the amount of

to Gayle G Kennedy \$ 362.07
For Services and expenses for the month of September

On behalf of the Corporation, I, the undersigned Representative, do hereby certify as follows

(1) The above described obligation has been incurred and is presently due and payable and has not been paid, or has previously been paid and reimbursement for such payment is appropriate, and that said obligation is a proper charge against the Construction Fund,

(2) Payment of such obligation is in conformance with restrictions on use of proceeds set forth in Section 7 02 of the Agreement, and

(3) No Event of Default has occurred and is continuing

Approval of Payment from the Corporation's Construction Fund maintained at NationsBank, Richmond Branch in the amount of \$ Three hundred sixty-two dollars and 07/100

for the purpose(s) described above is evidenced by my manual signature hereon and the approval of the Commissioner's Court of Fort Bend County evidenced hereon

FORT BEND FLOOD CONTROL WATER
SUPPLY CORPORATION

Don Russell, Authorized Representative

Date 9-22-99

***Gayle G. Kennedy
3910 Southwestern
Houston, Texas 77005***

September 22, 1999

Invoice for the
Fort Bend Flood Control
Water Supply Corporation

Fee for services rendered for the month of September	\$ 350 00
Expenses for the month of September	<u>\$ 12 07</u>
Total	\$ 362 07

Please remit to **Gayle G Kennedy
3910 Southwestern
Houston, Texas 77005**

Invoice

Postage - \$ 4 62

Paper - \$ 4 20

Copies - \$ 3 25

Total \$ 12 07



Your Printing Solution.

13885 S W Freeway
(at Sugar Creek)
Sugar Land, TX 77478
(281) 242-6633

Owned and operated by
Ralph, Mike and Charles Lojo

Date 8-25-99

Quantity	Description	Amount
30	Copies	3.00

Cash Receipt

Tax 25
Total 325

INVOICE TRANSMITTAL

AS PER ORIGINAL

12-Digit Distribution 264-006-2640-4010
Vendor Number 742015555
Purchase Order Number (s) REQ CERT 1411

Vendor Name DISTRICT DATA SERVICES, INC.		
Address	8558 KATY FREEWAY SUITE 119	
City	HOUSTON	
State	Zip Code	Date
TX	77024-1849	9-28-99

Descriptor / Invoice Numbers
BOOKKEEPING SERVICES FOR JULY & AUGUST 1999

Amount
865.10
Total \$ 865.10-

County Auditor's Use Only
Check Type
Applied By
Received
Paid

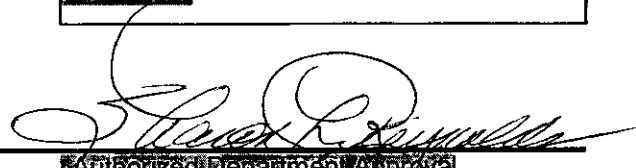
Authorized Departmental Approval

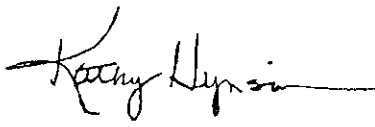
Treasurer's Register Stamp and Number
125630
COUNTY TREASURER FORT BEND COUNTY REGISTERED
SEP 28 1999

REQUISITION CERTIFICATE NO. 1411

County Treasurer
Fort Bend County, Texas

Pursuant to Section 2 05 of the Agreement between Fort Bend Flood Control Water Supply Corporation (the "Corporation") and Fort Bend County, Texas and Fort Bend County Drainage District relating to the issuance by the Corporation of its \$20,325,000 Revenue Bonds, Series 1989, \$6,850,000 Revenue Bonds, Series 1995 and \$14,060,000 Revenue Refunding Bonds, Series 1999, such Agreement dated as of April 1, 1989, the First Supplement to such Agreement dated April 18, 1995 and the Second Supplement to such Agreement dated June 15 (the "Agreement"), the County Treasurer of Fort Bend County is directed, upon execution of this certificate, to pay from the Corporation's Construction Fund the amount of

to District Data Services \$ 865.10
for Bookkeeping services for July and August 1999

On behalf of the Corporation, I, the undersigned Representative, do hereby certify as follows

(1) The above described obligation has been incurred and is presently due and payable and has not been paid, or has previously been paid and reimbursement for such payment is appropriate, and that said obligation is a proper charge against the Construction Fund,

(2) Payment of such obligation is in conformance with restrictions on use of proceeds set forth in Section 7 02 of the Agreement, and

(3) No Event of Default has occurred and is continuing

Approval of Payment from the Corporation's Construction Fund maintained at NationsBank, Richmond Branch in the amount of \$ Eight hundred and sixty-five dollars and 70/100

for the purpose(s) described above is evidenced by my manual signature hereon and the approval of the Commissioner's Court of Fort Bend County evidenced hereon

FORT BEND FLOOD CONTROL WATER
SUPPLY CORPORATION



Don Russell, Authorized Representative

Date 9-22-99

District Data Services, Inc.
8558 Katy Freeway, Suite 119
Houston, Texas 77024
713-932-7908

BOARD OF DIRECTORS

FORT BEND FLOOD CONTROL CORPORATION

WE BILL YOU FOR BOOKKEEPING SERVICES RENDERED AS FOLLOWS:

SERVICÉS FOR THE MONTH OF: JULY, 1999

MONTHLY FEE -	\$ <u>400.00</u>
AFTER 5.00 PM MEETING -	<u> </u>
ADDITIONAL TIME -	<u> </u>
INVESTMENT REPORT -	<u> </u>
EXPENSES -	<u>32.55</u>
STORAGE -	<u> </u>
OTHER -	<u> </u>
<u> </u>	<u> </u>
<u> </u>	<u> </u>
<u> </u>	<u> </u>
TOTAL AMOUNT DUE:	\$ <u>432.55</u>

RESPECTFULLY SUBMITTED,

DISTRICT DATA SERVICES, INC

DISTRICT DATA SERVICES, INC.

DISTRICT: FORT BEND FLOOD CONTROL CORPORATION

BOOKKEEPING SERVICES FOR THE MONTH OF JULY, 19 88

MONTHLY FEE \$ 400.00

ADDITIONAL TIME AT MEETING _____ HOURS @ _____ / HOUR _____

BEGINNING AT/OR CONTINUING BEYOND 5.00 PM OR LATER _____

EXPENSES

PARKING
MILEAGE:	38	MILES @	.325	/ MILE	12.35
COPIES:	51	COPIES @	.20	/ COPY	10.20
POSTAGE		@ 32		@	
ENVELOPES:		@ 03 EACH			

OTHER EXPENSES

FAXES 5 @ 2.00 _____ 10.00

TOTAL AMOUNT OF INVOICE: \$432.55

District Data Services, Inc.
8558 Katy Freeway, Suite 119
Houston, Texas 77024
713-932-7908

BOARD OF DIRECTORS

FORT BEND FLOOD CONTROL CORPORATION

WE BILL YOU FOR BOOKKEEPING SERVICES RENDERED AS FOLLOWS:

SERVICES FOR THE MONTH OF: AUGUST, 1999

MONTHLY FEE -	\$ <u>400.00</u>
AFTER 5 00 PM MEETING -	<u> </u>
ADDITIONAL TIME -	<u> </u>
INVESTMENT REPORT -	<u> </u>
EXPENSES -	<u>32.55</u>
STORAGE -	<u> </u>
OTHER -	<u> </u>
<u> </u>	<u> </u>
<u> </u>	<u> </u>
<u> </u>	<u> </u>
TOTAL AMOUNT DUE	\$ <u><u>432.55</u></u>

RESPECTFULLY SUBMITTED,

DISTRICT DATA SERVICES, INC

AS PER ORIGINAL

DISTRICT DATA SERVICES, INC.

DISTRICT: FORT BEND FLOOD CONTROL CORPORATION

BOOKKEEPING SERVICES FOR THE MONTH OF August, 19 99

MONTHLY FEE: \$ 400.00

ADDITIONAL TIME AT MEETING _____ HOURS @ _____ / HOUR.

BEGINNING AT/OR CONTINUING BEYOND 5:00 PM OR LATER

EXPENSES.

PARKING:		
MILEAGE:	<u>38</u> MILES @ <u>.325</u> / MILE		<u>12.35</u>
COPIES	<u>51</u> COPIES @ <u>.20</u> / COPY		<u>10.20</u>
POSTAGE:	@ <u>32</u>	@	
ENVELOPES:	@ <u>03</u> EACH		

OTHER EXPENSES:

PAKES 5 @ 2.00 10.00

TOTAL AMOUNT OF INVOICE: \$ 432.55

INVOICE TRANSMITTAL

AS PER ORIGINAL

12 Digit Distribution 264-006-2640-4010
Vendor Number 467942368
Purchase Order Number(s) REQ CERT 1407

Vendor Name RICK ZAPALAC		
Address P O BOX 231		
City ROSENBERG		
State TX	Zip Code 77471	Date 9-28-99

Description / Invoice Numbers
DIRECTORS FEE FOR 2 MEETINGS

Amount
200.00
Total \$ 200.00 -

County Auditor's Use Only

Cheq. Type _____

Audited By _____

Received _____

Paid _____

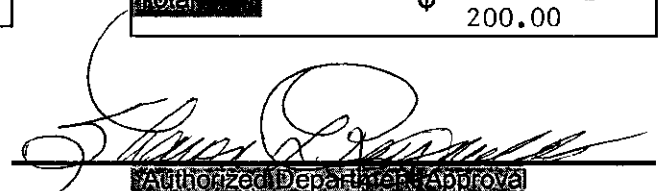

Authorized Department Approval

Treasurer's Register Stamp and Number

125637

COUNTY TREASURER
FORT BEND COUNTY
REGISTERED

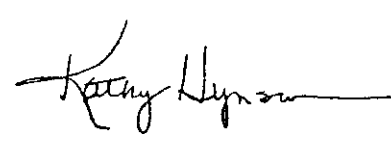
SEP 28 1999



REQUISITION CERTIFICATE NO. 1407

County Treasurer
Fort Bend County, Texas

Pursuant to Section 2 05 of the Agreement between Fort Bend Flood Control Water Supply Corporation (the "Corporation") and Fort Bend County, Texas and Fort Bend County Drainage District relating to the issuance by the Corporation of its \$20,325,000 Revenue Bonds, Series 1989, \$6,850,000 Revenue Bonds, Series 1995 and \$14,060,000 Revenue Refunding Bonds, Series 1999, such Agreement dated as of April 1, 1989, the First Supplement to such Agreement dated April 18, 1995 and the Second Supplement to such Agreement dated June 15, 1999 (the "Agreement"), the County Treasurer of Fort Bend County is directed, upon execution of this certificate, to pay from the Corporation's Construction Fund the amount of

to Rick Zapalac \$ 200.00
for Directors fees for attending 2 meetings @ \$ 100.00 per meeting.

On behalf of the Corporation, I, the undersigned Representative, do hereby certify as follows

(1) The above described obligation has been incurred and is presently due and payable and has not been paid, or has previously been paid and reimbursement for such payment is appropriate, and that said obligation is a proper charge against the Construction Fund,

(2) Payment of such obligation is in conformance with restrictions on use of proceeds set forth in Section 7 02 of the Agreement, and

(3) No Event of Default has occurred and is continuing

Approval of Payment from the Corporation's Construction Fund maintained at NationsBank, Richmond Branch in the amount of \$ Two hundred dollars and no/100

for the purpose(s) described above is evidenced by my manual signature hereon and the approval of the Commissioner's Court of Fort Bend County evidenced hereon

FORT BEND FLOOD CONTROL WATER
SUPPLY CORPORATION

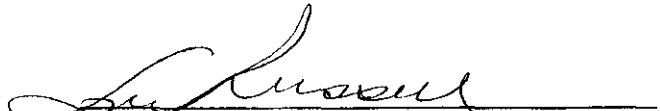
Don Russell, Authorized Representative

Date 9-22-99

INVOICE TRANSMITTAL

AS PER ORIGINAL

12-Digit Distribution 264-006-2640-4010
Vendor Number 454848384
Purchase Order Number(s)
REQ. CERT 1408

Vendor Name A.J. COLBERT		
Address 6923 McCULLUM		
City MISSOURI CITY		
State TX	Zip Code 77489	Date 9-28-99

Description / Invoice Numbers
DIRECTORS FEE FOR 1 MEETING

Amount
100.00
Total \$ 100.00

County Auditor's Use Only
Check Type _____
Audited By _____
Received _____
Paid _____

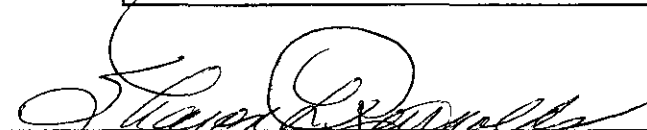
Authorized Department Approval

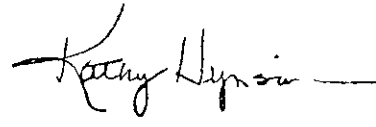
Treasurer's Register Stamp and Number
125630
COUNTY TREASURER FORT BEND COUNTY REGISTERED
SEP 28 1999

REQUISITION CERTIFICATE NO. 1408

County Treasurer
Fort Bend County, Texas

Pursuant to Section 2 05 of the Agreement between Fort Bend Flood Control Water Supply Corporation (the "Corporation") and Fort Bend County, Texas and Fort Bend County Drainage District relating to the issuance by the Corporation of its \$20,325,000 Revenue Bonds, Series 1989, \$6,850,000 Revenue Bonds, Series 1995 and \$14,060,000 Revenue Refunding Bonds, Series 1999, such Agreement dated as of April 1, 1989, the First Supplement to such Agreement dated April 18, 1995 and the Second Supplement to such Agreement dated June 15, 1999 (the "Agreement"), the County Treasurer of Fort Bend County is directed, upon execution of this certificate, to pay from the Corporation's Construction Fund the amount of

to A.J. Colbert \$ 100.00
for Directors fees for attending 1 meeting @ \$ 100.00 per meeting.

On behalf of the Corporation, I, the undersigned Representative, do hereby certify as follows

(1) The above described obligation has been incurred and is presently due and payable and has not been paid, or has previously been paid and reimbursement for such payment is appropriate, and that said obligation is a proper charge against the Construction Fund,

(2) Payment of such obligation is in conformance with restrictions on use of proceeds set forth in Section 7 02 of the Agreement, and

(3) No Event of Default has occurred and is continuing

Approval of Payment from the Corporation's Construction Fund maintained at NationsBank, Richmond Branch in the amount of \$ One hundred dollars and no/100

for the purpose(s) described above is evidenced by my manual signature hereon and the approval of the Commissioner's Court of Fort Bend County evidenced hereon

FORT BEND FLOOD CONTROL WATER
SUPPLY CORPORATION

Don Russell, Authorized Representative

Date 9-22-99

INVOICE TRANSMITTAL

AS PER ORIGINAL

12 Digit Distribution 264-006-2640-4010
Vendor Number 451588385
Purchase Order Number (S)
REQ CERT 1405

Vendor Name PAUL JEFF COUNCIL		
Address P.O BOX 1067		
City ROSENBERG		
State TX	Zip Code 77471	Date 9-28-99

Description / Invoice Numbers
DIRECTORS FEE FOR 2 MEETINGS

Amount
200.00
Total \$ 200.00-

County Auditor's Use Only

Check Type _____

Audited By _____

Received _____

Paid _____

[Signature]
Authorized Department Approval

Treasurer's Register Stamp and Number
125639

COUNTY TREASURER
FORT BEND COUNTY
REGISTERED

SEP 28 1999

[Signature]

REQUISITION CERTIFICATE NO. 1405

County Treasurer
Fort Bend County, Texas

Pursuant to Section 2 05 of the Agreement between Fort Bend Flood Control Water Supply Corporation (the "Corporation") and Fort Bend County, Texas and Fort Bend County Drainage District relating to the issuance by the Corporation of its \$20,325,000 Revenue Bonds, Series 1989, \$6,850,000 Revenue Bonds, Series 1995, and \$14,060,000 Revenue Refunding Bonds, Series 1999 such Agreement dated as of April 1, 1989, the First Supplement to such Agreement dated April 18, 1995 and the Second Supplement to such Agreement dated June 15, 1999 (the "Agreement"), the County Treasurer of Fort Bend County is directed, upon execution of this certificate, to pay from the Corporation's Construction Fund the amount of

to Paul J Council \$ 200.00
for Directors fees for attending 2 meetings @ \$ 100.00 per meeting.

On behalf of the Corporation, I, the undersigned Representative, do hereby certify as follows

(1) The above described obligation has been incurred and is presently due and payable and has not been paid, or has previously been paid and reimbursement for such payment is appropriate, and that said obligation is a proper charge against the Construction Fund,

(2) Payment of such obligation is in conformance with restrictions on use of proceeds set forth in Section 7 02 of the Agreement, and

(3) No Event of Default has occurred and is continuing

Approval of Payment from the Corporation's Construction Fund maintained at NationsBank, Richmond Branch in the amount of \$ Two hundred dollars and no/100

for the purpose(s) described above is evidenced by my manual signature hereon and the approval of the Commissioner's Court of Fort Bend County evidenced hereon

FORT BEND FLOOD CONTROL WATER
SUPPLY CORPORATION

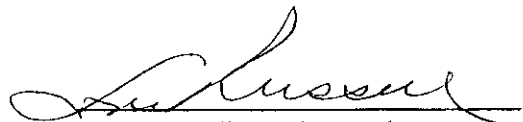

Don Russell, Authorized Representative

Date 9-22-99

INVOICE TRANSMITTAL

AS PER ORIGINAL

12 Digit Distribution
264-006-2640-4010
Vendor Number
461746254
Purchase Order Number(s)
REQ CERT 1406

Vendor Name		
JIM CONDREY		
Address		
3939 PLEASANT VALLEY DR		
City		
MISSOURI CITY		
State	Zip Code	Date
TX	77549	9-28-99

Description / Invoice Number
DIRECTORS FEES FOR 3 MEETINGS

Amount
300.00
Total \$ 300.00-

County Auditor's Use Only	
Checked by:	
Audited by:	
Received:	
Paid:	

Authorized Department Approval

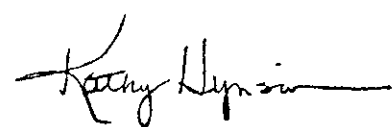
Treasurer's Register Stamp and Number
125640
COUNTY TREASURER FORT BEND COUNTY REGISTERED
SEP 28 1999

REQUISITION CERTIFICATE NO. 1406

County Treasurer
Fort Bend County, Texas

Pursuant to Section 2 05 of the Agreement between Fort Bend Flood Control Water Supply Corporation (the "Corporation") and Fort Bend County, Texas and Fort Bend County Drainage District relating to the issuance by the Corporation of its \$20,325,000 Revenue Bonds, Series 1989, \$6,850,000 Revenue Bonds, Series 1995 and \$14,060,000 Revenue Refunding Bonds, Series 1999, such Agreement dated as of April 1, 1989, the First Supplement to such Agreement dated April 18, 1995 and the Second Supplement to such Agreement dated June 15, 1999 (the "Agreement"), the County Treasurer of Fort Bend County is directed, upon execution of this certificate, to pay from the Corporation's Construction Fund the amount of

to Jim Condrey \$ 300.00
for Directors fees for attending 3 meetings @ \$ 100.00 per meeting.

On behalf of the Corporation, I, the undersigned Representative, do hereby certify as follows

(1) The above described obligation has been incurred and is presently due and payable and has not been paid, or has previously been paid and reimbursement for such payment is appropriate, and that said obligation is a proper charge against the Construction Fund,

(2) Payment of such obligation is in conformance with restrictions on use of proceeds set forth in Section 7 02 of the Agreement, and

(3) *No Event of Default has occurred and is continuing*

Approval of Payment from the Corporation's Construction Fund maintained at NationsBank, Richmond Branch in the amount of \$ Three hundred dollars and no/100

for the purpose(s) described above is evidenced by my manual signature hereon and the approval of the Commissioner's Court of Fort Bend County evidenced hereon

FORT BEND FLOOD CONTROL WATER
SUPPLY CORPORATION

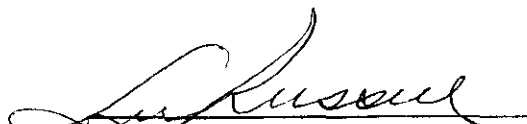
Don Russell, Authorized Representative

Date 9-22-99

REQUISITION CERTIFICATE NO. 1404

County Treasurer
Fort Bend County, Texas

Pursuant to Section 2 05 of the Agreement between Fort Bend Flood Control Water Supply Corporation (the "Corporation") and Fort Bend County, Texas and Fort Bend County Drainage District relating to the issuance by the Corporation of its \$20,325,000 Revenue Bonds, Series 1989, \$6,850,000 Revenue Bonds, Series 1995 and \$14,060,000 Revenue Refunding Bonds, Series 1999, such Agreement dated as of April 1, 1989, the First Supplement to such Agreement dated April 18, 1995 and the Second Supplement to such Agreement dated June 15, 1999 (the "Agreement"), the County Treasurer of Fort Bend County is directed, upon execution of this certificate, to pay from the Corporation's Construction Fund the amount of

to Don Russell \$ 100.00
for Directors fees for attending 1 meeting @ \$ 100.00 per meeting.

On behalf of the Corporation, I, the undersigned Representative, do hereby certify as follows

(1) The above described obligation has been incurred and is presently due and payable and has not been paid, or has previously been paid and reimbursement for such payment is appropriate, and that said obligation is a proper charge against the Construction Fund,

(2) Payment of such obligation is in conformance with restrictions on use of proceeds set forth in Section 7 02 of the Agreement, and

(3) No Event of Default has occurred and is continuing

Approval of Payment from the Corporation's Construction Fund maintained at NationsBank, Richmond Branch in the amount of \$ One hundred dollars and no/100

for the purpose(s) described above is evidenced by my manual signature hereon and the approval of the Commissioner's Court of Fort Bend County evidenced hereon

FORT BEND FLOOD CONTROL WATER
SUPPLY CORPORATION



Don Russell, Authorized Representative

Date 9-22-99

COMMISSIONERS COURT AGENDA REQUEST FORM

RETURN TO: AGENDA COORD -COUNTY JUDGE'S OFFICE

DATE SUBMITTED: 10/7/99

DEPT. SUBMITTED BY Co. Treas.

COMMISSIONERS COURT AGENDA FOR 10/12/99

DEPT. PHONE NO (281) 341-3750 #14

SUMMARY OF ITEM

Discuss and consider taking action on a resolution for budgeted retirement system options for 2000.

RENEWAL CONTRACT/AGREEMENT: Yes (X) No ()

LIST SUPPORTING DOCUMENTS ATTACHED: 11-07-99 13 5
 (Back-up documentation must be attached for consideration)

FINANCIAL SUMMARY:

BUDGETED ITEM:	ANNUALIZED DOLLARS	COMMENTS:
Yes (X) No () N/A ()	One Time ()	
Funding Source: fund _____ agcy _____ Object _____	Recurring ()	
	N/A ()	

Original Form Submitted with back up to County Judge's Office Yes ()

CC with back up:

Auditor	(281-341-3774)	Comm. Pct. 1	(281-344-0587)
Budget Officer	(281-344-3954)	Comm. Pct. 2	(281-403-8009)
County Attorney	(281-341-4557)	Comm. Pct. 3	(281-242-9060)
Purchasing Agent	(281-341-8642)	Comm. Pct. 4	(281-980-9077)

Instructions for submitting an Agenda Request:

- 1 Completely fill out agenda form, incomplete forms will not be processed
- 2 Fax or inter-office copies of agenda form with all back up information by Wednesday at 2:00 p.m to the departments listed above.
- 3 All original back-up must be received in the County Judges Office by 2 00 p m on Wednesday

RECOMMENDATION / ACTION REQUESTED:

No resolution if no plan change made
 Budget officer recommending no plan change
 In the 2000 Budget as no plan change



Texas County and District Retirement System

Mailing Address
P O Box 2034
Austin Texas 78768-2034

Austin Telephone (512) 328-8889
Toll-Free (800) 823-7782
Benefits Department Fax (512) 328-8887
Administration and
Communications Department Fax (512) 328-8708

BOARD OF TRUSTEES

Chairman
Giles Dalby
County Judge
Garza County

Vice-Chairman
Sam D Seale
Executive Director
Texas Association
of Counties

Maxine Darst
County Judge
Kaufman County

Martha Gustavsen
County Treasurer
Montgomery County

John R Marshall
Chief Appraiser
Tarrant County
Appraisal District

Bill Melton
County Treasurer
Dallas County

Steve Radack
County Commissioner
Harris County

Kathy Hodge Reeves
Tax Assessor-Collector
Midland County

John G Willy
County Judge
Brazoria County

STAFF

Terry Horton
Director

Ronald C Schultz, Sr
Investment Officer

May 1999

TO TCDRS Governing Boards
FROM Terry Horton, Director
RE **Employer Contribution Rate and ADCR Plan Options for 2000**

Your Commissioners Court or Governing Board has previously adopted the Annually Determined Contribution Rate (ADCR) method for financing your TCDRS retirement plan. The employer contribution rate for an ADCR plan is recalculated each year to the level necessary to adequately fund the level of pension benefits elected for your plan. The required employer contribution rate for your plan will rise or fall each year according to the degree of changes in several factors of plan experience, especially in the amount of TCDRS-covered payroll and the percentage of terminated employees who withdraw their personal deposits.

To determine your basic required employer rate for 2000, simply refer to line 7 of the column "Present Plan" on your attached Exhibit A. (Be sure to read the qualifying footnotes at the bottom of the Exhibit.)

If You are not Making Plan Changes

If you wish to make no changes in rights, benefits or retirement eligibility standards, or do not wish to adopt or amend an optional employer contribution rate, simply return the enclosed No Plan Change Notice confirming your correct employee and employer contribution rates for 2000. **The No Plan Change Notice can be signed only by the official TCDRS correspondent or the chief governing officer of your county or district.**

If You Wish to Make Plan Changes for 2000

If you wish to change rights, benefits or eligibility standards, or adopt a cost-of-living allowance for retirees to be effective 1/1/2000, you must execute the appropriate order or resolution authorizing the changes and provide TCDRS a certified copy of that order/resolution by 5 p.m. on 12/31/1999. **You must also execute an order or resolution if you wish to adopt a higher optional employer contribution rate or amend a previously adopted optional rate.** Please refer to the instructions for amending your ADCR plan and the explanation of plan options.

New Plan Options and Elections Available for 2000

Legislative amendments of the state statutes governing TCDRS have revised the list of plan elections available to subdivisions using the ADCR funding method.

- Effective 1/1/2000, your plan may elect to waive the 11% statutory cap on employer contributions. Subdivisions that make this election will be allowed to contribute more.

Physical Address:

901 MoPac Expressway South • Barton Oaks Plaza IV Suite 500 • Austin Texas 78746

than 11% of the TCDRS-covered payroll to finance their retirement plan. A subdivision might choose to exercise this funding option in order to

- 1) adopt benefit options or levels not previously available because of cost limits,
 - 2) restore benefit levels previously reduced because of funding deficiency or budget factors,
 - 3) "pre-fund" future benefit increases,
 - 4) more fully fund overall plan costs in general, or
 - 5) set, for budgetary planning purposes, the employer cost at a constant percentage
- Also effective 1/1/2000, ADCR Plans may elect to grant a "Flat-Rate COLA" -- a uniform cost-of-living increase to all retirees (i.e., 2%, 5%, etc.) Increases based on a percentage of the cumulative change in the Consumer Price Index ("Catch-up COLA") may still be adopted. The new COLA option gives subdivisions a less costly alternative to the previous CPI-based COLA option.
 - Also effective 1/1/2000, a member with 10 years of service in his or her subdivision who has been discharged under honorable conditions from any of the U.S. armed forces may establish up to 60 months of service credit for active-duty military service performed during any period. **The credit granted is length-of-service credit only** -- No payment is required from the member and no deposit is made to the member's account. This provision is automatic for all subdivisions -- fixed-rate or ADCR -- that currently allow current service credit for military service.
 - The full-salary adjustment option is no longer available for plans that formerly limited the amount of employee earnings subject to TCDRS deposits.

At the time of this mailing, the Legislature was still considering other bills that would make additional new options available for plan year 2000. TCDRS will keep you fully posted of any changes that become law and take effect for plan year 2000.

Special Studies Required for Some Rights and Credits

Certain ADCR plan options require that a special actuarial study be conducted in order to determine the employer cost. If you are interested in adopting a "buy-back" provision (repurchase of refunded service) or pre-membership credit, **you must request a study in writing by 9/1/1999**, to allow us time to complete the study and give you time to review the study results.

Alternative ADCR Plans

Your Exhibit A contains information about plan costs for 2000 and benefits previously elected for your ADCR plan. The exhibit also provides one or more alternative ADCR plan options, or provides an explanation as to why alternative options are not available. The alternatives shown usually include both higher and lower levels of costs/benefits, but commonly do not represent the full range of alternative plans available to your subdivision. You may contact TCDRS to request additional ADCR plan options that are based on other levels of contributions and benefits. It is important to remember that *increases in the employee deposit rate and current service credit percentage (matching ratio) will increase both employee benefit levels and employer costs, while decreases in these factors will lower both benefit levels and employer costs.*

TCDRS Assistance Available

TCDRS Communications representatives are available at **1-800-823-7782** to assist you in discussing plan options for 2000 and to answer any questions you may have about plan costs, benefits and completion of orders and resolutions. We will also travel, to the extent that we are available, to meet *with you and/or your governing board to discuss plan costs and options.* TCDRS staff will also attend most professional association conferences for county and district officials and will be happy to discuss your plan costs and options with you at those gatherings.

cc: local corresponding official

encl: Instructions for Previous Amendment of ADCR Plan, Explanation of ADCR Plan Options, Form ADCR-3B, No Plan Change Notice

EXHIBIT A for Year 2000
Fort Bend County — # 178 in the Texas County and District Retirement System
Present Plan and Selected Options for a Subdivision Previously Adopting an ADCR Plan

Basic Plan Characteristics		Present Plan	ADCR Plan 1	ADCR Plan 2	ADCR Plan 3	ADCR Plan 4	
PLAN PROVISIONS	Employee Deposit Rate	1 7%	7%	7%			
	Current Service Credit % (Matching Ratio)	2 200% (\$2 00/\$1)	225% (\$2 25/\$1)	175% (\$1 75/\$1)			
	Prior Service Credit %	3 165%	165%	165%			
BASE EMPLOYER CONTRIBUTION RATES FOR 2000	Vesting Provision / Rule of Provision	4 8 Yrs/Rule of 75	8 Yrs/Rule of 75	8 Yrs/Rule of 75			
	Normal Cost Rate	5 6.93 %	7.73 %	6.13 %			
BENEFIT CREDITS AS A % OF PAY () = INCREASE	Unfunded Actuarial Liability Rate	6 3.57	3.85	3.36			
	Calculated Employer Contribution Rate ⁽²⁾	7 10.50 % ⁽¹⁾	11.58 %	9.49 %			
PLAN ASSETS AND LIABILITIES	Current Service through 1999	8 21 00 % ⁽⁵⁾	22.75% (8%)	21 00% (0%)			
	Current Service after 1999	9 21 00 %	22.75% (8%)	19.25% (-8%)			
OPTIONAL BENEFIT COSTS ⁽³⁾	Prior Service	10 23 10 %	23 10% (0%)	23 10% (0%)			
	Actuarial Liability (Total Accrued Costs)	11 \$ 91,966,911	\$ 93,125,900	\$ 90,817,888			
OPTIONAL BENEFIT COSTS ⁽³⁾	Plan Assets (Actuarial Value)	12 70,992,113	70,992,113	70,992,113			
	Unfunded Liability (Amount to Finance)	13 \$ 20,974,798	\$ 22,133,787	\$ 19,825,775			
OPTIONAL BENEFIT COSTS ⁽³⁾	Years to Finance Unfunded Liability	14 20 Years	20 Years	20 Years			
	8-year Vesting and Retirement at Age 60 ⁽²⁾ Rule of 75 ⁽²⁾	15 adopted	adopted	adopted			
Optional Cost-of-Living (COLA) Annuity Increases⁽⁴⁾							
Monthly Benefit Increases as a % of the Consumer Price Index	17 30%	40%	50%	60%	70%	80%	
Additional Employer Contribution Rate ^(2,3)	18 14%	.20%	25%	32%	38%	45%	
Monthly Benefit Increases as a % of the Total Annuity	Additional Employer Contribution Rate ^(2,3)	19 1%	2%	3%	4%	5%	6%
		20 03%	.07%	10%	.14%	17%	21%

(1) For comparison, the calculated employer contribution rate for 1999 under the Present Plan is 10.85%
(2) Calculated employer contribution rates must be increased by the additional contribution rate applicable to any of the optional benefits (8-year vesting, rule of 75, cost-of-living annuity increases) being adopted for 2000
(3) Benefits that produce a total calculated employer contribution rate greater than 10.50% cannot be adopted unless the employer waives the statutory maximum rate
(4) No previous cost-of-living annuity increases have been adopted
(5) For current service after 1998 only. Benefit credits before 1999 were 22.75% of pay for 1998 and 23.10% before 1998

COMMISSIONERS COURT AGENDA REQUEST FORM

RETURN TO: AGENDA COORD.-COUNTY JUDGE'S OFFICE

DATE SUBMITTED: 10/7/99

SUBMITTED BY: Ann Werlein

AGENDA

DEPARTMENT: Co Attorney

ITEM

COURT AGENDA DATE: 10/12/99

PHONE NO.: 281-341-4555

15 A B

SUMMARY OF ITEM:

Hold a public hearing to discuss Senate Bill 712 regarding Mobile Home Park Development.

RENEWAL CONTRACT/AGREEMENT: Yes () No ()

LIST SUPPORTING DOCUMENTS ATTACHED: Senate Bill 712

FINANCIAL SUMMARY:

BUDGETED ITEM. Yes () No () N/A () Funding Source: fund _____ agcy _____ Object _____	ANNUALIZED DOLLARS.		COMMENTS.
	One Time ()	Recurring ()	
	N/A ()		

Original Form Submitted with back up to County Judge's Office: Yes ()

CC with back up:

yes () Auditor	(281-341-3774)	yes () Comm. Pct. 1	(281-342-0587)
yes () Budget Officer	(281-344-3954)	yes () Comm. Pct. 2	(281-403-8009)
yes () County Attorney	(281-341-4557)	yes () Comm. Pct. 3	(281-242-9060)
yes () Purchasing Agent	(281-341-8642)	yes () Comm. Pct. 4	(281-980-9077)

Instructions for submitting an Agenda Request

- 1 Completely fill out agenda form, incomplete forms will not be processed.
- 2 Fax or inter-office copies of agenda form with all back up information by Wednesday at 2:00 p.m to the departments listed above.
- 3 All original back-up must be received in the County Judges Office by 2 00 p m on Wednesday

RECOMMENDATION / ACTION REQUESTED:

We will receive public comments on this, but the "Public Notice" in the newspaper was not published therefore the actually hearing will be reset for Octobe 26, 1999.

AN ACT

AS PER ORIGINAL

1-1 relating to requiring manufactured home rental communities to
 1-2 comply with county infrastructure regulations.

1-3 BE IT ENACTED BY THE LEGISLATURE OF THE STATE OF TEXAS.

1-4 SECTION 1 Section 232.007, Local Government Code, is
 1-5 amended by amending Subsection (a) and adding Subsections (c)
 1-6 through (h) to read as follows

1-7 (a) In this section

1-8 (1) "Manufactured [~~,"~~ "manufactured] home rental
 1-9 community" means a plot or tract of land that is separated into two
 1-10 or more spaces or lots that are rented, leased, or offered for rent
 1-11 or lease, for a term of less than 60 months without a purchase
 1-12 option, for the installation of manufactured homes for use and
 1-13 occupancy as residences

1-14 (2) "Business day" means a day other than a Saturday,
 1-15 Sunday, or holiday recognized by this state

1-16 (c) After a public hearing and after notice is published in
 1-17 a newspaper of general circulation in the county, the commissioners
 1-18 court of a county, by order adopted and entered in the minutes of
 1-19 the commissioners court, may establish minimum infrastructure
 1-20 standards for manufactured home rental communities located in the
 1-21 county outside the limits of a municipality. The minimum standards
 1-22 may include only:

1-23 (1) reasonable specifications to provide adequate
 1-24 drainage in accordance with standard engineering practices,
 2-1 including specifying necessary drainage culverts and identifying
 2-2 areas included in the 100-year flood plain,

2-3 (2) reasonable specifications for providing an
 2-4 adequate public or community water supply, including specifying the
 2-5 location of supply lines, in accordance with Subchapter C, Chapter
 2-6 341, Health and Safety Code,

2-7 (3) reasonable requirements for providing access to
 2-8 sanitary sewer lines, including specifying the location of sanitary
 2-9 sewer lines, or providing adequate on-site sewage facilities in
 2-10 accordance with Chapter 366, Health and Safety Code,

2-11 (4) a requirement for the preparation of a survey
 2-12 identifying the proposed manufactured home rental community
 2-13 boundaries and any significant features of the community, including
 2-14 the proposed location of manufactured home rental community spaces,
 2-15 utility easements, and dedications of rights-of-way, and

2-16 (5) reasonable specifications for streets or roads in
 2-17 the manufactured rental home community to provide ingress and
 2-18 egress access for fire and emergency vehicles

2-19 (d) The commissioners court may not adopt minimum
 2-20 infrastructure standards that are more stringent than requirements
 2-21 adopted by the commissioners court for subdivisions. The
 2-22 commissioners court may only adopt minimum infrastructure standards
 2-23 for ingress and egress access by fire and emergency vehicles that
 2-24 are reasonably necessary.

2-25 (e) If the commissioners court adopts minimum infrastructure
 2-26 standards for manufactured home rental communities, the owner of
 3-1 land located outside the limits of a municipality who intends to
 3-2 use the land for a manufactured home rental community must have an
 3-3 infrastructure development plan prepared that complies with the
 3-4 minimum infrastructure standards adopted by the commissioners court
 3-5 under Subsection (c)

3-6 (f) Not later than the 60th day after the date the owner of
 3-7 a proposed manufactured home rental community submits an
 3-8 infrastructure development plan for approval, the county engineer
 3-9 or another person designated by the commissioners court shall
 3-10 approve or reject the plan in writing. If the plan is rejected,
 3-11 the written rejection must specify the reasons for the rejection
 3-12 and the actions required for approval of the plan. The failure to
 3-13 reject a plan within the period prescribed by this subsection
 3-14 constitutes approval of the plan

AS PER ORIGINAL

3-15 (g) Construction of a proposed manufactured home rental
 3-16 community may not begin before the date the county engineer or
 3-17 another person designated by the commissioners court approves the
 3-18 infrastructure development plan. The commissioners court may
 3-19 require inspection of the infrastructure during or on completion of
 3-20 its construction. If a final inspection is required, the final
 3-21 inspector must be completed not later than the second business day
 3-22 after the date the commissioners court or the person designated by
 3-23 the commissioners court receives a written confirmation from the
 3-24 owner that the construction of the infrastructure is complete. If
 3-25 the inspector determines that the infrastructure complies with the
 3-26 infrastructure development plan, the commissioners court shall
 4-1 issue a certificate of compliance not later than the fifth business
 4-2 day after the date the final inspection is completed. If a final
 4-3 inspection is not required, the commissioners court shall issue a
 4-4 certificate of compliance not later than the fifth business day
 4-5 after the date the commissioners court or the person designated by
 4-6 the commissioners court receives written certification from the
 4-7 owner that construction of the infrastructure has been completed in
 4-8 compliance with the infrastructure development plan.

4-9 (n) A utility may not provide utility services, including
 4-10 water, sewer, gas, and electric services, to a manufactured home
 4-11 rental community subject to an infrastructure development plan or
 4-12 to a manufactured home in the community unless the owner provides
 4-13 the utility with a copy of the certificate of compliance issued
 4-14 under Subsection (g). This subsection applies only to

- 4-15 (1) a municipality that provides utility services,
- 4-16 (2) a municipally owned or municipally operated
- 4-17 utility that provides utility services,
- 4-18 (3) a public utility that provides utility services,
- 4-19 (4) a nonprofit water supply or sewer service
- 4-20 corporation organized and operating under Chapter 67, Water Code,
- 4-21 that provides utility services,
- 4-22 (5) a county that provides utility services; and
- 4-23 (6) a special district or authority created by state
- 4-24 law that provides utility services.

4-25 SECTION 2 The change in law made by this Act applies only
 4-26 to a manufactured rental home community for which construction is
 5-1 commenced on or after the date minimum infrastructure standards
 5-2 adopted by the commissioners court as provided by Section 232.007,
 5-3 Local Government Code, as amended by this Act, take effect.

_____ President of the Senate	_____ Speaker of the House
I hereby certify that S B No 712 passed the Senate on April 29, 1999, by the following vote Yeas 30, Nays 0	

_____ Secretary of the Senate
I hereby certify that S B No 712 passed the House on May 8, 1999, by a non-record vote

_____ Chief Clerk of the House

Approved

Date

Governor

**FORT BEND COUNTY
COMMISSIONERS COURT AGENDA REQUEST FORM
RETURN TO: AGENDA COORD.-COUNTY JUDGE'S OFFICE**

DATE SUBMITTED Sept 28, 1999 SUBMITTED BY: Jim Edwards *Jim Edwards* AGENDA
 DEPARTMENT: Budget Office ITEM #
 COURT AGENDA DATE: Oct 12, 1999 PHONE NO.: 344-3937 **15 C-E**

SUMMARY OF ITEM:

Hold Public Hearing to discuss the Proposed 2000 Budget for Fort Bend County

RENEWAL CONTRACT/AGREEMENT: Yes () No ()

LIST SUPPORTING DOCUMENTS ATTACHED:
 (Back-up documentation must be attached for consideration)

FINANCIAL SUMMARY:

BUDGETED ITEM:	ANNUALIZED DOLLARS:	COMMENTS:
Yes () No () N/A (<input checked="" type="checkbox"/>)	One Time ()	
Funding Source:	Recurring ()	
fund _____ agcy _____ Object _____		
N/A ()		

Original Form Submitted with back up to County Judge's Office: Yes ()

CC with back up:

Yes () Auditor	(281-341-3774)	Yes () Comm. Pct. 1	(281-344-0587)
Yes () Budget Officer	(281-344-3954)	Yes () Comm. Pct. 2	(281-403-8009)
Yes () County Attorney	(281-341-4557)	Yes () Comm. Pct. 3	(281-242-9060)
Yes () Purchasing Agent	(281-341-8642)	Yes () Comm. Pct. 4	(281-980-9077)

Instructions for submitting an Agenda Request:

1. Completely fill out agenda form, incomplete forms will not be processed.
2. Fax or inter-office copies of agenda form with all back up information by Wednesday at 2:00 p.m. to the departments listed above.
3. All original back-up must be received in the County Judges Office by 2:00 p.m. on Wednesday.

RECOMMENDATION / ACTION REQUESTED:

**FORT BEND COUNTY
 COMMISSIONERS COURT AGENDA REQUEST FORM
 RETURN TO: AGENDA COORD.-COUNTY JUDGE'S OFFICE**

DATE SUBMITTED Sept 28, 1999 **SUBMITTED BY:** Jim Edwards *Edwards* **AGENDA**
DEPARTMENT: Budget Office **ITEM #**
COURT AGENDA DATE: Oct 12, 1999 **PHONE NO.:** 344-3937

SUMMARY OF ITEM:

Discuss and consider accepting the 2000 salary schedule for county elected officials and approved positions for FY2000

RENEWAL CONTRACT/AGREEMENT: Yes () No ()

LIST SUPPORTING DOCUMENTS ATTACHED:

(Back-up documentation must be attached for consideration)

FINANCIAL SUMMARY:

BUDGETED ITEM:	ANNUALIZED DOLLARS:	COMMENTS:
Yes () No () N/A (<input checked="" type="checkbox"/>)	One Time ()	
Funding Source: fund _____ agcy _____ Object _____ N/A ()	Recurring ()	

Original Form Submitted with back up to County Judge's Office: Yes ()

CC with back up:

Yes () Auditor (281-341-3774)	Yes () Comm. Pct. 1 (281-344-0587)
Yes () Budget Officer (281-344-3954)	Yes () Comm. Pct. 2 (281-403-8009)
Yes () County Attorney (281-341-4557)	Yes () Comm. Pct. 3 (281-242-9060)
Yes () Purchasing Agent (281-341-8642)	Yes () Comm. Pct. 4 (281-980-9077)

Instructions for submitting an Agenda Request:

1. Completely fill out agenda form, incomplete forms will not be processed.
2. Fax or inter-office copies of agenda form with all back up information by Wednesday at 2:00 p.m. to the departments listed above.
3. All original back-up must be received in the County Judges Office by 2:00 p.m. on Wednesday.

RECOMMENDATION / ACTION REQUESTED:



Budget Office
Fort Bend County, Texas

James W Edwards
Budget Officer

(281) 344-3937
Fax (281) 344-3954

Fort Bend County Elected Officials' Proposed 2000 Salaries

The Fort Bend County Commissioners Court will consider increasing the salaries of certain County elected officials at a regular session of the Court which will meet at 1 00 p m Tuesday, October 12, 1999 The elected officials and their present and proposed annual salaries are listed as follows

<u>Elected Officials</u>	<u>Present 1999 Annual Salaries</u>	<u>Proposed 2000 Annual Salaries</u>
County Judge	\$70,073	\$72,175
Commissioner, Pct 1	\$67,090	\$69,103
Commissioner, Pct 2	\$67,090	\$69,103
Commissioner, Pct 3	\$67,090	\$69,103
Commissioner, Pct 4	\$67,090	\$69,103
Sheriff	\$73,813	\$76,027
County Attorney	\$79,633	\$82,022
County Clerk	\$65,412	\$67,374
County Tax Assessor/Collector	\$67,090	\$69,103
County Treasurer	\$63,735	\$65,647
District Clerk	\$65,412	\$67,374
Justice of the Peace, Pct 1, Pl 1	\$55,894	\$57,571
Justice of the Peace, Pct 1, Pl 2	\$55,894	\$57,571
Justice of the Peace, Pct 2	\$55,894	\$57,571
Justice of the Peace, Pct 3	\$55,894	\$57,571
Justice of the Peace, Pct 4	\$55,894	\$57,571
Constable, Pct 1	\$52,632	\$54,211
Constable, Pct 2	\$52,632	\$54,211
Constable, Pct 3	\$52,632	\$54,211
Constable, Pct 4	\$52,632	\$54,211

**FORT BEND COUNTY
 COMMISSIONERS COURT AGENDA REQUEST FORM
 RETURN TO: AGENDA COORD.-COUNTY JUDGE'S OFFICE**

DATE SUBMITTED <u>Sept 28, 1999</u>	SUBMITTED BY: <u>Jim Edwards</u> <i>Jim Edwards</i>	AGENDA
COURT AGENDA DATE: <u>Oct 12, 1999</u>	DEPARTMENT: <u>Budget Office</u>	ITEM #
	PHONE NO.: <u>344-3937</u>	

SUMMARY OF ITEM:
 Discuss and consider accepting the 2000 Proposed Budget for Fort Bend County

RENEWAL CONTRACT/AGREEMENT: Yes () No ()

LIST SUPPORTING DOCUMENTS ATTACHED:
 (Back-up documentation must be attached for consideration)

FINANCIAL SUMMARY:

BUDGETED ITEM:	ANNUALIZED DOLLARS:	COMMENTS:
Yes () No () N/A (<input checked="" type="checkbox"/>)	One Time ()	
Funding Source: fund _____ agcy _____ Object _____	Recurring ()	
N/A ()		

Original Form Submitted with back up to County Judge's Office: Yes ()

CC with back up:

Yes () Auditor (281-341-3774)	Yes () Comm. Pct. 1 (281-344-0587)
Yes () Budget Officer (281-344-3954)	Yes () Comm. Pct. 2 (281-403-8009)
Yes () County Attorney (281-341-4557)	Yes () Comm. Pct. 3 (281-242-9060)
Yes () Purchasing Agent (281-341-8642)	Yes () Comm. Pct. 4 (281-980-9077)

Instructions for submitting an Agenda Request:

1. Completely fill out agenda form, incomplete forms will not be processed.
2. Fax or inter-office copies of agenda form with all back up information by Wednesday at 2:00 p.m. to the departments listed above.
3. All original back-up must be received in the County Judges Office by 2:00 p.m. on Wednesday

RECOMMENDATION / ACTION REQUESTED:



15/D

TEXAS DISTRICT & COUNTY ATTORNEYS ASSOCIATION

1210 Nueces • Austin • Texas 78701 • 512/474-2436 • FAX. 512/478-4112 • <http://www.tdcaa.com>

MEMORANDUM

TO: COUNTY ATTORNEYS

RE: HB 804 IMPLEMENTATION

DATE: SEPTEMBER 2, 1999

As you know, HB 804 took effect on September 1. In response to a number of inquiries, below we provide information that should be helpful to you, your commissioners court and county treasurer in implementing the bill.

Q. How and when will the funds be forwarded by the Comptroller of Public Accounts?

A. Chuck Demos with the Comptroller's Office (1-800-531-5441 Ext. 33609) informs us that the funds will be disbursed by the end of September. The County Treasurer in each county entitled to receive funds under the Act will receive a check from the Comptroller in the total amount authorized for that county in the bill (The amount each county is entitled to receive depends upon the number of counties served by the district attorney in that county; 1 county = \$50,850, 2 counties = \$25,425, and 3 or more counties = \$16,950. If a county is served by 2 district attorneys, special rules apply.)

Q. How are these state funds to be spent, and who determines the allocation?

A. The county attorney is authorized to use the state supplemental funds for salary and/or the expenses of the county attorney's office. The county attorney should prepare a budget detailing how the funds are to be allocated.

4 Q: Does Local Government Code Sec. 152.013, requiring the publication of increases in salaries and expenses of county officials, apply to the supplemental state funds authorized under HB 804?

A. As we interpret Sec. 152.013, the publication requirement is for the purpose of advising local residents of increases in county compensation and expenses financed by local funding sources, and to allow taxpayers to lodge objections and seek reductions in the proposed increases. Since the supplemental state support authorized by HB 804 does not involve the use of county funds, nor does it implicate or require increases in local taxes or fees to finance the increases, it is our opinion that this section in the Local Government Code **does not** apply. Further, the commissioners court has no authority to determine how the state supplemental funds are to be spent, thus obviating the need for notice prior to the annual budget hearing. This state funding for the support of the county attorney offices can be viewed in the same light as the funding the state provides to the office of district attorney; the local publication requirement has never been applied to the district attorney state supplemental funds, and thus should not apply to the newly-authorized allotments to county attorneys.

Q: If a county attorney elects to apply the supplemental state funding to the officeholder's salary (either in whole or in part), who is responsible for the payment of benefits such as FICA and Medicare tax?

A. The responsibility for the payment of employment taxes such as FICA and Medicare are always a shared responsibility between the employer and employee. In the case of a county attorney who elects to take all or part of the supplemental state funds provided by HB 804 as salary, the officeholder would be responsible for the employee's share of the taxes, while the county, as the employer, is responsible for the employer's share.

Q. Can the commissioners court require that the employer's (county's) share of fringe benefits be deducted from the amount provided by the state under HB 804?

A Requiring the county attorney, as an employee, to bear the total cost of FICA, Medicare and other employee taxes is not authorized, and in fact would likely violate federal labor laws which prohibit an employer from requiring that the entire cost of employment taxes be borne by the employee. Further, there are several documents and support materials prepared by the Legislature during the



Budget Office
Fort Bend County, Texas

15 E

James W. Edwards
Budget Officer

(281) 344-3937
Fax (281) 344-3954

October 28, 1999

The Honorable Dianne Wilson
County Clerk
Fort Bend County
301 Jackson
Richmond, TX 77469

Dear Ms Wilson

Attached is the adopted budget for Fort Bend County for Fiscal Year 2000. In accordance with VTCA Local Government Code Section 111.066, I am hereby delivering the adopted budget to you for filing so as to make it available for public viewing.

A copy will also be filed with the Fort Bend County Auditor, Robert Grayless.

Thank you for your courtesy. If you have any questions, I am available to answer them at 281 344 3937.

Sincerely,

James Edwards
Fort Bend County Budget Officer

Attachment 2000 Adopted Budget

cc County Auditor

15
J. W. Edwards
COUNTY CLERK
OCT 28 1999

99 OCT 28 AM 10:58

11:11 AM '99

**BUDGET OF
FORT BEND COUNTY, TEXAS
FOR THE YEAR 2000**

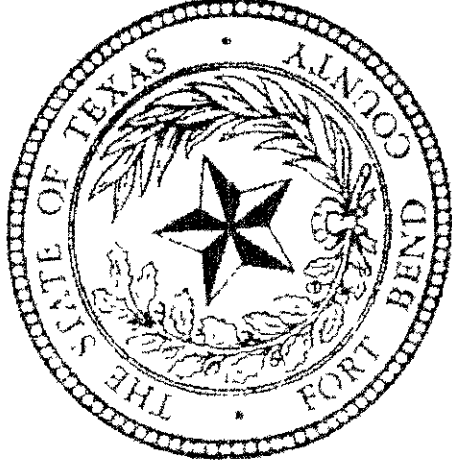

**James W. Edwards
Budget Officer**

**Robert N. Grayless
County Auditor**

**BUDGET OF
FORT BEND COUNTY, TEXAS
FOR THE YEAR 2000**

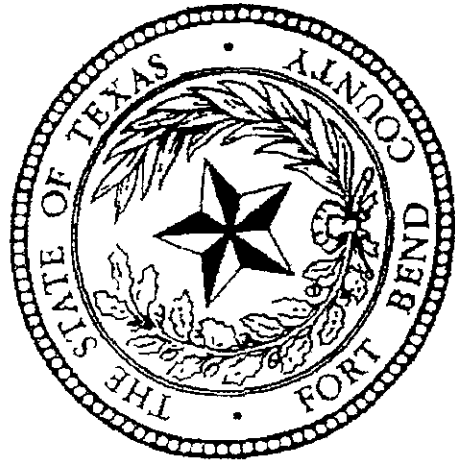

99 OCT 28 AM 10:50
COUNTY CLERK
FORT BEND COUNTY

**James W. Edwards
Budget Officer**

**Robert N. Grayless
County Auditor**

**FORT BEND COUNTY, TEXAS
2000 ADOPTED BUDGET
TABLE OF CONTENTS**

Tax Rate Summary	1
Fund Recapitulation	2
Budget Summary	3
General Fund Revenue	10
General Fund Disbursements	
County Judge	13
County Clerk	14
Tax Assessor/Collector	15
District Clerk	16
County Auditor	17
County Treasurer	18
Human Resources	19
Building Maintenance	20
Juvenile Detention	22
240 th District Court	24
268 th District Court	25
District Attorney	26
328 th District Court	28
Child Support	29
County Court at Law #1	30
Juvenile Board	31
Community Supervision & Corrections	32
Juvenile Probation	33
Justice of the Peace, Precinct 1, Place 2	34
Justice of the Peace, Precinct 1, Place 1	35
Justice of the Peace, Precinct 3	36
Justice of the Peace, Precinct 4	37

Constable, Precinct 1	38
Constable, Precinct 2	40
Constable, Precinct 3	42
Constable, Precinct 4	44
Sheriff – Enforcement	45
Sheriff – Detention	47
Vehicle Maintenance	49
Social Services	51
Library	52
Health Department	54
Extension Service	56
Fairgrounds	58
Emergency Medical Services	59
Veterans Service	61
Management Information Systems	62
Animal Control	63
Telecommunications	64
Bail Bond Board	65
Fire Marshal	66
Children’s Protective Services	68
Capital Outlay	69
Engineering	70
Engineering – Landfill	72
County Indigent Health Care	73
Non-Departmental	74
Emergency Management	76
Justice of the Peace, Precinct 2	78
Purchasing Agent	79
County Attorney	80
County Court at Law #2	81
County Court at Law #3	82

Associate Judge – County Court at Law	83
Department of Public Safety	84
Impact Court	86
Risk Management/Insurance	87
Elections Administration	89
Parks Department	90
Commissioner, Precinct 1	92
Commissioner, Precinct 2	93
Commissioner, Precinct 3	94
Commissioner, Precinct 4	95
Budget Office	96
Mail Center	97
Records Management/Grants	98
Administrative Services	99
387 th District Court	100
400 th District Court	101
Director of Health and Human Services	102
Road & Bridge Revenue and Disbursements	103
Road & Bridge Revenue	104
Road & Bridge Expenditures	104
Drainage District Maintenance Fund	106
Drainage District Revenue	107
Drainage District – County Expenditures	106
County Law Library Revenue and Disbursements	107
County Law Library Revenue	109
County Law Library Expenditures	110
Gus George Law Academy Revenue and Disbursements	109
Gus George Law Academy Revenue	111
Gus George Law Academy Expenditures	112
Records Management – County Clerk Revenues and Disbursements	114
Records Management – County Clerk Revenue	114

Records Management – County Clerk Expenditures	115
Fort Bend County Records Management Fund Revenue and Disbursements	
FBC Records Management Revenue	116
FBC Records Management Expenditures	117
Courthouse Security Fund Revenue and Disbursements	
Courthouse Security Revenue	118
Courthouse Security Expenditures	119
Child Support Title IV-D Reimbursement	120
Child Support Title IV-D Revenue	120
Child Support Title IV-D Expenditures	121
Debt Service Funds	
Fund 306	122
Fund 309	125
Fund 310	128
Fund 311	132

**TAX RATE SUMMARY
ADOPTED 10/05/99**

	Tax Year		
	1999	1998	1997
Net Assessed Value			
			\$14,024,668,542
General Fund	0 49367	0 47348	\$0 4595
Road and Bridge Fund	0 05143	0 05989	\$0 0642
Interest and Sinking Fund	0 04500	0 05113	\$0 0644
	0 59010	0 58450	\$0 5881
Total County Rate			
Lateral Road/Flood Control	0 00000	0 00000	\$0 0000
Drainage District Maintenance Fund	0 03400	0 03960	\$0 0410
TOTAL TAX RATE	0 62410	0 62410	\$0 6291

Fund Recapitulation

**FISCAL YEAR 2000
BUDGET FINANCE SUMMARY
AS ADOPTED 10/12/99**

	ALL FUNDS	GENERAL	ROAD AND BRIDGE	DRAINAGE	LAW LIBRARY	GUS GEORGE LAW ACADEMY
Estimated Beginning Balance	\$28,344,398	\$20,752,924	\$2,337,606	\$2,538,034	\$116,854	\$52,244
Estimated Tax Revenue	\$84,902,118	\$67,158,514	\$6,996,500	\$4,625,336	0	\$0
Estimated Other Revenue	\$21,853,043	\$14,918,223	\$5,115,000	\$450,000	\$99,500	\$69,000
Total Estimated Revenue	\$106,755,161	\$82,076,737	\$12,111,500	\$5,075,336	\$99,500	\$69,000
2000 Requested Budget	\$115,160,885	\$86,925,900	\$14,202,199	\$5,413,194	\$119,294	\$84,971
Change in Fund Balance	-\$8,405,724	-\$4,849,163	-\$2,090,699	-\$337,858	-\$19,794	-\$15,971
Estimated Ending Balance	\$19,938,674	\$15,903,761	\$246,907	\$2,200,176	\$97,060	\$36,273
	RECORDS MANAGEMENT COUNTY CLERK	COUNTY RECORDS MANAGEMENT	COURTHOUSE SECURITY	CHILD SUPPORT	TOTAL DEBT	
Estimated Beginning Balance	\$329,673	\$98,926	\$674,721	\$10,000	\$1,433,416	
Estimated Tax Revenue	\$0	\$0	\$0	\$0	\$6,121,768	
Estimated Other Revenue	\$478,000	\$55,000	\$145,000	\$35,000	\$523,320	
Total Estimated Revenue	\$478,000	\$55,000	\$145,000	\$35,000	\$6,645,088	
2000 Requested Budget	\$497,321	\$55,267	\$125,000	\$11,130	\$7,726,609	
Change in Fund Balance	-\$19,321	-\$267	\$20,000	\$23,870	-\$1,081,521	
Estimated Ending Balance	\$310,352	\$98,659	\$694,721	\$33,870	\$351,895	

Budget Summary

2000 Adopted Budget by Department

Agency	Department	1999 Adopted	2000 Adopted	Change	Percent change
001	County Judge	304,716	353,616	48,899	16.05%
002	County Clerk	1,659,326	1,848,021	188,695	11.37%
003	Tax Assessor/Collector	1,680,198	2,110,585	250,387	13.46%
004	District Clerk	1,496,489	1,663,509	187,020	12.50%
005	County Auditor	848,940	859,753	10,813	1.27%
006	County Treasurer	368,435	559,311	190,876	51.81%
007	Human Resources	359,946	420,702	60,756	16.88%
008	Building Maintenance	1,107,199	1,148,801	41,602	3.76%
009	Juvenile Detention	1,379,900	1,561,822	181,922	13.18%
010	240th District Court	355,848	359,144	3,296	0.93%
011	268th District Court	360,775	418,785	58,010	16.08%
012	District Attorney	2,979,088	3,165,713	186,625	6.26%
013	328th District Court	404,226	411,627	7,401	1.83%
014	Child Support	280,603	335,901	45,298	15.59%
015	County Court at Law #1	419,836	436,655	16,819	4.01%
016	Juvenile Board	21,946	21,134	-812	-3.70%
017	Adult Probation	102,055	79,903	-22,152	-21.71%
018	Juvenile Probation	3,040,743	3,512,361	471,618	15.51%
019	Justice of the Peace 1,2	228,447	282,481	54,034	23.65%
020	Justice of the Peace 1,1	211,984	234,421	22,437	10.58%
021	Justice of the Peace 3	227,656	245,715	18,059	7.93%
022	Justice of the Peace 4	242,813	285,571	42,758	17.61%
023	Constable 1	662,951	745,593	82,642	12.47%
024	Constable 2	838,305	1,008,269	169,964	20.27%
025	Constable 3	787,811	586,516	-181,295	-23.61%
026	Constable 4	679,679	806,005	126,326	18.59%
027	Sheriff - Enforcement	18,677,854	11,469,467	-7,208,387	-38.59%
0271	Sheriff - Detention		9,181,282		Note 1
028	Vehicle Maintenance	1,003,004	994,943	-8,061	-0.80%
029	Social Services	380,987	508,528	127,541	33.48%
030	Library	6,459,643	6,851,361	391,738	6.06%
031	Health Dept	1,021,037	991,049	-29,988	-2.94%
032	Extension Service	547,894	615,040	67,146	12.26%
033	Parkgrounds	308,346	328,357	20,011	6.49%
034	EMS	3,069,934	3,705,010	635,076	20.69%
035	Veterans Service	77,680	59,140	-18,540	-23.87%
036	MIS	3,218,735	3,830,814	612,079	19.02%
037	Animal Control	324,575	350,346	25,771	7.94%
038	Telecommunications	1,019,816	1,065,979	46,163	4.53%
039	Bail Bond Board	57,466	57,892	426	0.74%
040	Fire Marshal	1,380,457	1,095,867	-284,590	-21.19%
041	CPS *Move to 045	173,010	0		
042	Capital Outlay	1,636,076	4,424,200	2,788,124	170.42%
043	Engineering	1,185,068	1,177,074	-7,994	-0.67%

2000 Adopted Budget by Department

Agency	Department	1999 Adopted	2000 Proposed	Change	Percent change
0432	Landfill		169,565		Note 1
044	CIHC	3,222,222	3,222,181	69,959	2.22%
045	Non-Departmental	3,053,134	3,707,598	654,464	21.44%
046	Emergency Management	0	266,531		Note 2
052	Justice of the Peace 2	244,570	289,992	45,422	18.57%
053	Purchasing	477,478	399,695	-77,783	16.29%
054	County Attorney	615,312	644,013	28,701	4.66%
055	County Court at Law #2	421,632	441,520	19,888	4.72%
056	County Court at Law #3	415,670	433,073	17,403	4.19%
058	Associate Judge	0	105,419	105,419	Note 3
065	DPS	51,422	53,272	1,850	3.60%
0651	DPS - Weight & License	5,000	5,366	366	7.72%
067	Impact Court	228,284	194,373	-33,911	-14.85%
068	Risk Management	2,265,428	2,749,442	484,014	21.37%
069	Elections	387,472	550,411	162,939	42.05%
070	Parks Dept	716,234	804,042	87,808	12.26%
071	Commissioner 1	216,255	244,677	28,422	13.14%
072	Commissioner 2	358,800	373,391	14,591	4.07%
073	Commissioner 3	272,657	300,018	27,361	10.03%
074	Commissioner 4	268,864	277,742	7,878	2.92%
076	Budget Office	148,180	154,027	5,847	3.95%
077	Mail Center	409,928	431,281	21,353	5.21%
078	Records Management	235,925	278,445	42,520	18.02%
078	Administrative Services	148,328	137,155	-11,171	-7.53%
080	387th District Court	0	251,526		Note 3
081	400th District Court	0	88,817		Note 3
089	Dir of Health & Human Services	0	164,025		Note 3
General Fund Total		75,865,292	86,925,900	11,060,608	14.58%
FUND	Department	1999 Adopted	2000 Adopted	Change	Percent change
105	Road & Bridge	13,996,584	14,202,199	205,615	1.47%
115	Drainage District	5,377,166	5,413,194	36,028	0.67%
125	County Law Library	111,454	119,294	7,840	7.03%
126	Gus George Law Academy	79,700	84,971	5,271	6.61%
144	Records Management - CC	375,000	497,321	122,321	32.62%
147	FBC Records Management	41,400	55,267	13,867	33.50%
149	Courthouse Security	125,000	125,000	0	0.00%
860	Child Support	0	11,130		Note 4
777	Principal Retirement	4,280,000	4,605,000	325,000	7.59%
777	Interest and Fees	3,663,927	3,121,609	-542,318	-14.80%
GRAND TOTAL		103,915,523	115,160,885	11,245,362	10.82%

Note 1 Split Budget
 Note 2 Previously budgeted with Fire Marshal
 Note 3 New Office
 Note 4 Not budgeted in 1999

EXPENSE BUDGET BY AGENCY WITHIN ACTIVITY

1998 EXPENDITURE	BUDGET AS MODIFIED	EXP THRU 10/22/99	TOTAL EST EXPENDITURE	ACCOUNT NAME	AGENCY	BUDGET REQUEST	2000 RECOM ENDED	ADOPTED BUDGET
------------------	--------------------	-------------------	-----------------------	--------------	--------	----------------	------------------	----------------

GENERAL ADMINISTRATION								
\$616,228	\$832,837	\$114,097	\$0	COUNTY JUDGE	001	\$877,727	\$906,167	\$906,204
\$1,615,007	\$1,661,977	\$512,213	\$0	COUNTY CLERK	002	\$1,782,628	\$1,843,876	\$1,848,021
\$8,021,065	\$706,347	\$1,849,018	\$0	HUMAN RESOURCES	007	\$421,616	\$420,702	\$420,702
\$960,616	\$1,139,726	\$200,083	\$0	BUILDING MAINTENANCE	008	\$1,169,590	\$1,148,705	\$1,148,801
\$1,158,431	\$1,485,476	\$228,504	\$0	VEHICLE MAINTENANCE	028	\$1,100,362	\$994,942	\$994,943
\$4,851,421	\$4,472,815	\$693,906	\$0	MANAGEMENT INFORMATION SYSTEMS	036	\$4,525,111	\$3,830,811	\$3,830,814
\$829,732	\$1,036,046	\$155,363	\$0	TELECOMMUNICATION DIVISION	038	\$1,065,415	\$1,065,979	\$1,065,979
\$2,177,148	\$3,078,033	\$1,119,798	\$0	NON-DEPARTMENTAL	045	\$3,478,620	\$3,707,598	\$3,707,598
\$423,402	\$480,382	\$117,022	\$0	PURCHASING AGENT	053	\$476,945	\$400,264	\$399,695
\$1,610,316	\$1,594,917	\$1,143,565	\$0	RISK MANAGEMENT/INSURANCE	068	\$2,727,823	\$2,749,442	\$2,749,442
\$406,612	\$727,925	\$94,789	\$0	ELECTIONS ADMINISTRATION	069	\$543,665	\$550,411	\$550,411
\$205,290	\$222,293	\$57,892	\$0	COMMISSIONER PRECINCT 1	071	\$235,996	\$244,677	\$244,677
\$344,751	\$365,444	\$100,909	\$0	COMMISSIONER PRECINCT 2	072	\$363,357	\$373,391	\$373,391
\$236,540	\$274,885	\$74,786	\$0	COMMISSIONER PRECINCT 3	073	\$296,214	\$300,018	\$300,018
\$244,496	\$271,312	\$71,072	\$0	COMMISSIONER PRECINCT 4	074	\$269,660	\$277,742	\$277,742
\$319,183	\$489,825	\$55,445	\$0	CENTRAL MAIL ROOM	077	\$432,605	\$431,052	\$431,281
\$233,870	\$251,345	\$62,192	\$0	RECORDS MANAGEMENT	078	\$272,911	\$278,281	\$278,445
\$13,446	\$151,214	\$29,821	\$0	DIRECTOR OF ADMINISTRATIVE SVCS	079	\$145,680	\$138,200	\$137,155
\$24,267,559	\$19,242,799	\$6,680,478	\$0	TOTAL FOR ACTIVITY	1000	\$20,185,925	\$19,662,598	\$19,665,319

FINANCIAL ADMINISTRATION								
\$1,883,259	\$1,941,920	\$587,671	\$0	TAX ASSESSOR/COLLECTOR	003	\$2,093,859	\$2,094,348	\$2,110,585
\$803,188	\$849,172	\$238,566	\$0	COUNTY AUDITOR	005	\$842,658	\$861,892	\$859,753
\$376,662	\$400,054	\$115,964	\$0	COUNTY TREASURER	006	\$573,687	\$559,003	\$559,311
\$165,292	\$171,878	\$39,261	\$0	BUDGET OFFICE	076	\$150,078	\$154,942	\$154,027
\$3,228,401	\$3,363,024	\$981,462	\$0	TOTAL FOR ACTIVITY	1100	\$3,660,282	\$3,670,185	\$3,683,676

ADMINISTRATION OF JUSTICE								
\$1,381,767	\$1,586,461	\$450,572	\$0	DISTRICT CLERK	004	\$1,471,771	\$1,679,940	\$1,683,509
\$1,272,604	\$1,381,900	\$392,436	\$0	JUVENILE DETENTION	009	\$1,746,039	\$1,561,597	\$1,561,822
\$259,241	\$357,544	\$52,470	\$0	240TH DISTRICT COURT	010	\$354,334	\$359,906	\$359,144
\$314,431	\$370,774	\$59,680	\$0	268TH DISTRICT COURT	011	\$415,274	\$419,546	\$418,785
\$2,775,025	\$3,205,060	\$879,891	\$0	DISTRICT ATTORNEY	012	\$3,348,806	\$3,170,759	\$3,165,713
\$421,153	\$411,110	\$96,924	\$0	328TH DISTRICT COURT	013	\$411,135	\$413,411	\$411,627
\$299,106	\$349,532	\$88,745	\$0	CHILD SUPPORT	014	\$346,871	\$348,094	\$347,031
\$430,221	\$420,617	\$110,078	\$0	COUNTY COURT-AT-LAW 1	015	\$430,551	\$437,117	\$436,655
\$20,035	\$21,946	\$4,406	\$0	JUVENILE BOARD	016	\$21,946	\$21,134	\$21,134
\$100,143	\$150,140	\$8,904	\$0	ADULT PROBATION	017	\$83,491	\$79,903	\$79,903
\$2,548,808	\$3,054,567	\$615,755	\$0	JUVENILE PROBATION	018	\$3,264,113	\$3,500,302	\$3,512,361
\$213,482	\$243,039	\$73,826	\$0	JUSTICE OF THE PEACE PCT1 PL2	019	\$269,990	\$279,555	\$282,481
\$200,271	\$224,594	\$64,582	\$0	JUSTICE OF THE PEACE PCT1 PL1	020	\$226,081	\$234,421	\$234,421

** FORT BEND COUNTY **
EXPENSE BUDGET BY AGENCY WITHIN ACTIVITY

1998	BUDGET AS MODIFIED	EXP THRU 10/22/99	TOTAL EST EXPENDITURE	ACCOUNT NAME	AGENCY	BUDGET REQUEST	*2000 RECOM ENDED	ADOPTED BUDGET
ADMINISTRATION OF JUSTICE								
\$210,174	\$230,833	\$68,764	\$230,833	\$0 JUSTICE OF THE PEACE 3	021	\$239,456	\$245,715	\$245,715
\$236,724	\$255,430	\$73,740	\$255,430	\$0 JUSTICE OF THE PEACE 4	022	\$280,349	\$285,571	\$285,571
\$56,154	\$62,158	\$14,931	\$62,158	\$0 BAIL BOND BOARD OFFICE	039	\$56,603	\$57,892	\$57,892
\$232,223	\$284,988	\$75,214	\$284,988	\$0 JUSTICE OF THE PEACE 2	052	\$307,955	\$289,992	\$289,992
\$569,861	\$633,611	\$168,915	\$633,611	\$0 COUNTY ATTORNEY	054	\$628,036	\$650,724	\$644,013
\$389,965	\$422,408	\$99,488	\$422,408	\$0 COUNTY COURT AT LAW 2	055	\$435,817	\$441,982	\$441,520
\$618,717	\$517,579	\$130,410	\$517,579	\$0 COUNTY COURT AT LAW 3	056	\$427,330	\$433,537	\$433,073
\$285,721	\$228,284	\$51,657	\$228,284	\$0 ASSOCIATE COUNTY COURT-AT-LAW	058	\$105,194	\$106,725	\$105,419
\$0	\$0	\$0	\$0	\$0 IMPACT COURT	067	\$270,353	\$194,373	\$194,373
\$0	\$0	\$0	\$0	\$0 387TH DISTRICT COURT	080	\$353,348	\$251,526	\$251,526
\$113,894	\$114,454	\$34,077	\$114,454	\$0 400TH DISTRICT COURT	081	\$122,236	\$88,817	\$88,817
\$12,949,719	\$14,507,029	\$3,615,469	\$14,507,029	\$0 COUNTY LAW LIBRARY	616	\$117,938	\$119,116	\$119,294
\$12,949,719	\$14,507,029	\$3,615,469	\$14,507,029	TOTAL FOR ACTIVITY	1200	\$15,735,017	\$15,671,655	\$15,671,791
ROAD AND BRIDGE MAINTENANCE								
\$1,149,644	\$1,463,599	\$371,096	\$1,463,599	\$0 ENGINEERING DEPARTMENT	043	\$1,328,327	\$1,350,050	\$1,346,639
\$12,404,537	\$14,731,449	\$2,995,673	\$14,731,449	\$0 ROAD & BRIDGE	075	\$15,027,250	\$14,201,132	\$14,202,199
\$13,554,181	\$16,195,048	\$3,366,770	\$16,195,048	TOTAL FOR ACTIVITY	1300	\$16,355,577	\$15,551,182	\$15,548,838
HEALTH AND WELFARE								
\$681,878	\$394,825	\$154,944	\$394,825	\$0 SOCIAL SERVICES	029	\$558,130	\$508,528	\$508,528
\$824,626	\$1,244,669	\$264,255	\$1,244,669	\$0 HEALTH DEPARTMENT	031	\$1,156,958	\$990,744	\$991,049
\$3,082,957	\$3,248,360	\$906,742	\$3,248,360	\$0 EMERGENCY MEDICAL SERVICE	034	\$4,381,552	\$3,705,195	\$3,705,010
\$348,268	\$352,726	\$93,380	\$352,726	\$0 ANIMAL CONTROL	037	\$338,688	\$350,079	\$350,346
\$170,701	\$173,010	\$86,505	\$173,010	\$0 CHILDREN'S PROTECTIVE SERVICES	041	\$0	\$0	\$0
\$4,648,456	\$6,078,898	\$1,389,584	\$6,078,898	\$0 CIHC COORDINATOR	044	\$3,263,899	\$3,222,206	\$3,222,181
\$0	\$0	\$0	\$0	\$0 DIRECTOR OF HEALTH SERVICES	089	\$0	\$159,262	\$164,025
\$9,756,885	\$11,492,488	\$2,895,409	\$11,492,488	TOTAL FOR ACTIVITY	1400	\$9,699,227	\$8,936,014	\$8,941,139
COOPERATIVE SERVICE								
\$544,040	\$591,860	\$149,653	\$591,860	\$0 EXTENSION SERVICE	032	\$620,532	\$615,039	\$615,040
\$58,108	\$99,709	\$52,061	\$99,709	\$0 VETERANS SERVICE	035	\$57,162	\$58,841	\$59,140
\$602,148	\$691,569	\$201,714	\$691,569	TOTAL FOR ACTIVITY	1500	\$677,694	\$673,880	\$674,180
PUBLIC SAFETY								

EXPENSE BUDGET BY AGENCY WITHIN ACTIVITY

1998	BUDGET AS MODIFIED	EXP THRU 10/22/99	TOTAL EST EXPENDITURE	ACCOUNT NAME	AGENCY	BUDGET REQUEST	*2000 RECOM ENDED	ADOPTED BUDGET
PUBLIC SAFETY								
\$49,823	\$133,529	\$9,975	\$0	COUNTY JUDGE	001	\$133,529	\$125,000	\$125,000
\$1,125,332	\$1,154,911	\$297,518	\$0	CONSTABLE 1	023	\$721,960	\$745,593	\$745,593
\$909,918	\$908,603	\$206,530	\$0	CONSTABLE 2	024	\$1,053,676	\$1,008,269	\$1,008,269
\$532,654	\$543,348	\$161,266	\$0	CONSTABLE 3	025	\$571,056	\$586,516	\$586,516
\$765,824	\$738,231	\$204,759	\$0	CONSTABLE 4	026	\$778,773	\$806,005	\$806,005
\$16,726,869	\$20,520,929	\$5,271,259	\$0	SHERIFF'S DEPARTMENT	027	\$20,819,772	\$20,822,828	\$20,735,720
\$0	\$0	\$0	\$0	FIRE MARSHAL	040	\$1,257,747	\$1,095,867	\$1,095,867
\$1,343,490	\$1,400,780	\$218,922	\$0	EMERGENCY MANAGEMENT	046	\$1,346,503	\$266,531	\$266,531
\$99,127	\$74,389	\$13,983	\$0	DEPARTMENT OF PUBLIC SAFETY	065	\$61,483	\$58,658	\$58,658
\$21,553,038	\$25,474,720	\$6,384,211	\$0	TOTAL FOR ACTIVITY	1600	\$26,744,499	\$25,515,267	\$25,428,159
PARKS AND RECREATION								
\$269,703	\$331,532	\$50,313	\$0	FAIRGROUNDS	033	\$337,159	\$328,357	\$328,357
\$854,552	\$831,446	\$228,645	\$0	PARKS DEPARTMENT	070	\$822,185	\$806,491	\$804,042
\$1,124,255	\$1,162,978	\$278,957	\$0	TOTAL FOR ACTIVITY	1700	\$1,159,344	\$1,134,848	\$1,132,399
FLOOD CONTROL PROJECTS								
\$5,370,723	\$5,989,376	\$1,349,098	\$0	DRAINAGE DISTRICT	051	\$5,392,047	\$5,394,797	\$5,413,194
\$5,370,723	\$5,989,376	\$1,349,098	\$0	TOTAL FOR ACTIVITY	1800	\$5,392,047	\$5,394,797	\$5,413,194
LIBRARIES AND EDUCATION								
\$7,311,201	\$8,676,954	\$1,638,984	\$0	LIBRARY	030	\$7,264,574	\$6,849,515	\$6,851,381
\$7,311,201	\$8,676,954	\$1,638,984	\$0	TOTAL FOR ACTIVITY	1900	\$7,264,574	\$6,849,515	\$6,851,381
CAPITAL OUTLAY								
\$4,395,443	\$1,744,449	\$469,564	\$0	CAPITAL OUTLAY	042	\$1,744,449	\$4,424,200	\$4,424,200
\$4,395,443	\$1,744,449	\$469,564	\$0	TOTAL FOR ACTIVITY	2000	\$1,744,449	\$4,424,200	\$4,424,200
PRINCIPAL RETIREMENT								
\$217,112	\$0	\$0	\$0	COUNTY JUDGE	001	\$0	\$0	\$0
\$4,055,000	\$4,280,000	\$0	\$0	DEBT SERVICE	777	\$4,280,000	\$4,605,000	\$4,605,000
\$4,272,112	\$4,280,000	\$0	\$0	TOTAL FOR ACTIVITY	3100	\$4,280,000	\$4,605,000	\$4,605,000
INTEREST AND FISCAL CHARGES								

EXPENSE BUDGET BY AGENCY WITHIN ACTIVITY

1998 EXPENDITURE	BUDGET AS MODIFIED	1999 EXP THRU 10/22/99	TOTAL EST EXPENDITURE	ACCOUNT NAME	AGENCY	BUDGET REQUEST	*2000 RECOM ENDED	ADOPTED BUDGET
				INTEREST AND FISCAL CHARGES				
\$8,126	\$0	\$0	\$0	COUNTY JUDGE	001	\$0	\$0	\$0
\$4,007,353	\$3,663,927	\$398	\$398	DEBT SERVICE	777	\$3,663,927	\$3,121,609	\$3,121,609
\$4,015,478	\$3,663,927	\$398	\$398	TOTAL FOR ACTIVITY	3200	\$3,663,927	\$3,121,609	\$3,121,609
				TRANSFER OUT				
\$66,906	\$0	\$0	\$0	COUNTY JUDGE	001	\$0	\$0	\$0
\$0	\$0	\$0	\$0	COUNTY TREASURER	006	\$0	\$0	\$0
\$23,930	\$0	\$0	\$0	JUVENILE PROBATION	018	\$0	\$0	\$0
\$0	\$0	\$0	\$0	SHERIFF'S DEPARTMENT	027	\$0	\$0	\$0
\$835,044	\$898,444	\$896,269	\$896,269	NON-DEPARTMENTAL	045	\$898,444	\$0	\$0
\$0	\$0	\$0	\$0	DEBT SERVICE	777	\$0	\$0	\$0
\$925,880	\$898,444	\$896,269	\$896,269	TOTAL FOR ACTIVITY	4000	\$898,444	\$0	\$0

RUN . 1 '99
 REPORT ID. 8112
 EXPENSE BUDGET BY AGENCY WITHIN ACTIVITY
 1998
 BUDGET AS MODIFIED
 EXP THRU 10/22/99
 TOTAL EST EXPENDITURE
 AGENCY BUDGET REQUEST RECOM ENDED ADOPTED BUDGET

\$113,327,023 \$117,382,805 \$28,758,783 \$0 GRAND TOTAL \$117,461,006 \$115,210,750 \$115,160,885

General Fund Revenue

REVENUE BUDGET BY REVENUE SOURCE

AGENCY: 999 REVENUE

ACTIVITY:

1998 REVENUE	BUDGET AS MODIFIED	REV THRU 10/22/99	TOTAL EST REVENUE	ACCOUNT NAME	REVENUE SOURCE	REVENUE REQUEST	*2000 RECOM ENDED	ADOPTED REVENUE
\$377,761	\$137,207	\$91,471		CENTRAL APPRAISAL DIST LEASE	CADL	\$137,207	\$137,207	
\$58,186	\$45,000	\$13,368		EMERGENCY MANAGEMENT ASST	RFEM	\$45,000	\$58,000	
\$69,422	\$40,000	\$32,224		NATIONAL LUNCH PROGRAM	RFLP	\$40,000	\$55,000	
\$120,881	\$73,000	\$50,207		NURSE'S SALARY GRANT	RSHD	\$73,000	\$76,000	
\$318,681	\$225,000	\$145,529		REINB FROM STATE	STAT	\$225,000	\$225,000	
\$0	\$0	\$68,515		FEDERAL PAYMENTS	OFED	\$0		
\$491,130	\$430,000	\$395,769		PENALTY & INTEREST-PROP TX	OPPI	\$430,000	\$430,000	
\$14,525	\$14,000	\$9,041		ANIMAL CONTROL FEES	00AC	\$14,000	\$15,000	
\$28,182	\$22,000	\$14,509		ATTORNEY'S FEES REIMBURSEMENT	00AF	\$22,000	\$22,000	
\$118,818	\$40,000	\$738		AUCTION	00AU	\$40,000	\$40,000	
\$6,000	\$6,000	\$4,000		BAIL BOND LICENSE FEES	00BB	\$6,000	\$6,000	
\$647,926	\$1,400,000	\$910,756		BOARD OF PRISONERS	00BP	\$1,400,000	\$1,500,000	
\$54,468	\$50,000	\$29,363		BEER, WINE & WHISKEY	00BW	\$50,000	\$50,000	
\$1,616,182	\$1,300,000	\$991,175		COUNTY CLERK	00CC	\$1,300,000	\$1,500,000	
\$821,714	\$650,000	\$455,654		CONTRACT DEPUTY REIMBURSEMENT	00CD	\$650,000	\$820,000	
\$4,006	\$4,000	\$2,454		COUNTY JUDGE	00CJ	\$4,000	\$4,000	
\$135,790	\$135,000	\$109,760		COUNTY LIBRARY	00CL	\$135,000	\$135,000	
\$247,162	\$190,000	\$233,288		COMMISSION ON PAY PHONES	00CP	\$190,000	\$250,000	
\$12,584	\$11,616	\$6,776		CITY OF RICHMOND	00CR	\$11,616	\$11,616	
\$48,581	\$58,000	\$32,538		CHILD SUPPORT	00CS	\$58,000	\$50,000	
\$0	\$0	\$0		CHILDRENS PROTECTIVE SERVICE	00CW	\$0		
\$1,350	\$4,000	\$410		COURT COST	00CX	\$4,000	\$4,000	
\$180,415	\$160,000	\$130,380		CONSTABLE PCT. 1	00C1	\$160,000	\$180,000	
\$136,708	\$120,000	\$95,969		CONSTABLE PCT. 2	00C2	\$120,000	\$175,000	

FUND. 010 GENERAL FUND AGENCY 999 REVENUE
 ORG ACTIVITY:

1998 REVENUE	BUDGET AS MODIFIED	1999 REV THRU 10/22/99	TOTAL EST REVENUE	ACCOUNT NAME	REVENUE SOURCE	REVENUE REQUEST	RECOM ENDED	ADOPTED REVENUE
\$125,372	\$130,000	\$62,182		CONSTABLE PCT 3	00C3	\$130,000	\$125,000	
\$87,126	\$90,000	\$64,902		CONSTABLE PCT. 4	00C4	\$90,000	\$90,000	
\$105,525	\$95,000	\$69,596		DISTRICT ATTORNEY	00DA	\$95,000	\$100,000	
\$452,065	\$450,000	\$275,371		DISTRICT CLERK	00DC	\$450,000	\$450,000	
\$40,445	\$0	\$7,100		DONATIONS	00DD	\$0		
\$1,563,082	\$1,200,000	\$960,877		EMERGENCY MEDICAL SERVICES	00ES	\$1,200,000	\$1,600,000	
\$108,426	\$85,000	\$55,063		FAIRGROUNDS RENTAL	00FR	\$85,000	\$90,000	
\$1,286,853	\$1,000,000	\$942,408		PROPERTY TAXES - DELINQUENT	00GD	\$1,000,000	\$1,000,000	
\$54,483,373	\$59,145,495	\$59,405,386		PROPERTY TAXES - CURRENT	00GP	\$59,145,495		
\$149,508	\$130,000	\$109,723		HEALTH DEPARTMENT	00HD	\$130,000	\$150,000	
\$138,868	\$0	\$913		INSURANCE CLAIMS	00IC	\$0	\$0	
\$3,056,904	\$2,500,000	\$1,797,777		INTEREST EARNED	00IE	\$2,500,000	\$2,800,000	
\$25,250	\$18,000	\$17,956		INSPECTIONS FEES	00IN	\$18,000	\$25,000	
\$13,993	\$14,000	\$8,232		JURY FEES	00JF	\$14,000	\$14,000	
\$47,713	\$39,000	\$16,893		JUSTICE OF THE PEACE - CIVIL	00JP	\$39,000	\$45,000	
\$187,212	\$160,000	\$161,282		JP PCT 1-2 FINES	00J1	\$160,000	\$190,000	
\$244,777	\$190,000	\$118,808		JP PCT 1-1 FINES	00J2	\$190,000	\$190,000	
\$182,062	\$170,000	\$134,820		JP PCT 3 - FINES	00J3	\$170,000	\$160,000	
\$276,860	\$245,000	\$181,304		JP PCT 4 - FINES	00J4	\$245,000	\$260,000	
\$774,209	\$300,000	\$209,124		MISCELLANEOUS REVENUE	00MS	\$300,000	\$300,000	
\$4,520	\$0	\$0		PARK FEES	00PF	\$0	\$0	
\$74,695	\$85,000	\$52,547		JP PCT 2 FINES	00P1	\$85,000	\$95,000	
\$362,010	\$50,000	\$183,882		REIMBURSEMENTS-MISCELLANEOUS	00RE	\$50,000	\$100,000	
\$4,110	\$0	\$131		RESTITUTION FEES	00RF	\$0	\$0	

FUND 010 GENERAL FUND
 AGENCY: 999 REVENUE
 ACTIVITY:

1998	BUDGET AS MODIFIED	1999 REV THRU 10/22/99	TOTAL EST REVENUE	ACCOUNT NAME	REVENUE SOURCE	REVENUE REQUEST	RECOM ENDED	ADOPTED REVENUE
\$8,548	\$8,400	\$3,726		RENTAL OF PROPERTY	00RP	\$8,400	\$5,400	
\$207,339	\$175,000	\$116,890		STATE ALCOHOLIC BEVERAGE	00SB	\$175,000	\$200,000	
\$451,179	\$145,000	\$112,925		SHERIFF'S DEPARTMENT	00SD	\$145,000	\$145,000	
\$172,792	\$65,000	\$86,945		SERVICE FEE EARNED FROM STATE	00SF	\$65,000	\$120,000	
\$885,691	\$900,000	\$438,857		TAX ASSESSOR/COLL FEES	00TA	\$900,000	\$900,000	
\$73,759	\$0	\$11,516		OPERATING TRANSFERS IN	00TR	\$0	\$0	
\$4,187	\$0	\$3,981,177		TOBACCO SETTLEMENT	00TS	\$0	\$0	
	\$0	\$104,233		REFUNDS	00DR	\$0	\$0	
\$71,108,945	\$72,504,718	\$73,516,440	\$0	TOTAL	TOTAL	\$72,504,718	\$14,918,223	\$0
\$71,108,945	\$72,504,718	\$73,516,440	\$0	TOTAL FOR ORGANIZATION		\$72,504,718	\$14,918,223	\$0
\$71,108,945	\$72,504,718	\$73,516,440	\$0	TOTAL FOR AGENCY	999	\$72,504,718	\$14,918,223	\$0
\$71,108,945	\$72,504,718	\$73,516,440	\$0	TOTAL FOR FUND	010	\$72,504,718	\$14,918,223	\$0

General Fund Disbursements

** FORT HEND COUNTY **
EXPENSE BUDGET BY OBJECT

FUND 010 GENERAL FUND		AGENCY: 002 COUNTY CLERK		FUNCC	
ORG 0020 COUNTY CLERK		ACTIVITY: 1000 GENERAL ADMINISTRATION		BUDGET REQUEST	ADOPTED BUDGET
1998 BUDGET AS MODIFIED	1999 EXP THRU 10/22/99	TOTAL EST EXPENDITURE	ACCOUNT NAME	RECOM ENDED	
\$1,019,135	\$1,139,534	\$234,968	\$0 SALARIES AND LABOR	\$1,192,979	\$1,233,015
\$40,381	\$0	\$1,341	\$0 TEMPORARY OR PART-TIME	\$10,000	\$10,000
\$15,850	\$17,607	\$3,261	\$0 LONGEVITY	\$17,621	\$17,590
\$78,674	\$89,057	\$17,746	\$0 SOCIAL SECURITY	\$93,376	\$96,436
\$102,500	\$127,285	\$25,880	\$0 RETIREMENT	\$133,166	\$137,567
\$182,000	\$184,800	\$184,800	\$0 INSURANCE(GROUP)	\$193,200	\$202,500
\$31,905	\$23,528	\$23,528	\$0 WORKERS COMP/UNEMPLOYMENT0600	\$37,606	\$24,578
\$7,806	\$6,190	\$3,050	\$0 TRAVEL REIMB/CONFERENCES 0701	\$7,400	\$6,600
\$30,686	\$0	\$0	\$0 PROPERTY AND EQUIPMENT 1010	\$8,480	\$10,385
\$30,686	\$0	\$0	\$0 CAPITAL ASSETS 1011	\$6,400	\$31,400
\$54,884	\$55,150	\$11,028	\$0 OFFICE SUPPLIES 1062	\$66,000	\$61,550
\$0	\$2,425	\$85	\$0 OTHER RENTALS 3020	\$2,500	\$900
\$20,501	\$16,401	\$6,526	\$0 FEES AND SERVICES 4010	\$13,900	\$15,500
\$1,615,008	\$1,661,977	\$512,213	\$0	\$1,782,628	\$1,848,021
\$1,615,008	\$1,661,977	\$512,213	\$0 TOTAL FOR ACTIVITY 1000	\$1,782,628	\$1,848,021
\$1,615,008	\$1,661,977	\$512,213	\$0 TOTAL FOR ORGANIZATION 0020	\$1,782,628	\$1,848,021
\$1,615,008	\$1,661,977	\$512,213	\$0 TOTAL FOR AGENCY 002	\$1,782,628	\$1,848,021

FUND. 010 GENERAL FUND		AGENCY: 003 TAX ASSESSOR/COLLECTOR		ACTIVITY: 1100 FINANCIAL ADMINISTRATION		FUNC.		
ORC 0030 TAX COLLECTOR/ASSESSOR	BUDGET AS MODIFIED 10/22/99	EXP THRU 10/22/99	TOTAL EST EXPENDITURE	ACCOUNT NAME	OBJECT	BUDGET REQUEST	*2000 RECOM ENDED	ADOPTED BUDGET
\$1,137,115	\$1,220,821	\$260,258	\$0	\$0 SALARIES AND LABOR	0200	\$1,297,500	\$1,335,946	\$1,335,947
\$72,847	\$50,000	\$14,881	\$0	\$0 TEMPORARY OR PART-TIME	0201	\$74,960	\$74,960	\$88,420
\$17,600	\$20,008	\$3,912	\$0	\$0 LONGEVITY	0250	\$21,762	\$21,584	\$21,584
\$91,292	\$98,749	\$20,877	\$0	\$0 SOCIAL SECURITY	0300	\$106,659	\$109,585	\$110,615
\$115,937	\$138,691	\$28,942	\$0	\$0 RETIREMENT	0400	\$150,897	\$155,105	\$156,586
\$204,750	\$189,000	\$189,000	\$0	\$0 INSURANCE(GROUP)	0500	\$201,600	\$211,500	\$211,500
\$38,101	\$25,954	\$25,954	\$0	\$0 WORKERS COMP/UNEEMPLOYMENT	0600	\$42,984	\$27,962	\$28,227
\$8,567	\$9,000	\$8,247	\$0	\$0 TRAVEL REIMB/CONFERENCES	0701	\$18,354	\$12,623	\$12,623
\$1,112	\$36,095	\$8,483	\$0	\$0 PROPERTY AND EQUIPMENT	1010	\$10,664	\$8,800	\$8,800
\$36,634	\$39,702	\$5,062	\$0	\$0 CAPITAL ASSETS	1011	\$30,540	\$18,000	\$18,000
\$18,291	\$21,000	\$3,474	\$0	\$0 HARDWARE PURCHASES	1012	\$16,010	\$14,090	\$14,090
\$36,634	\$39,702	\$5,062	\$0	\$0 OFFICE SUPPLIES	1062	\$59,930	\$50,000	\$50,000
\$18,291	\$21,000	\$3,474	\$0	\$0 UTILITIES	2000	\$21,400	\$23,000	\$23,000
\$3,210	\$880	\$147	\$0	\$0 OTHER RENTALS	3020	\$1,000	\$1,000	\$1,000
\$3,210	\$880	\$147	\$0	\$0 INFORMATION TECHNOLOGY	LE3021	\$4,327	\$4,327	\$4,327
\$16,981	\$15,219	\$4,254	\$0	\$0 SOFTWARE PURCHASES	3040	\$866	\$866	\$866
\$16,981	\$15,219	\$4,254	\$0	\$0 FEES AND SERVICES	4010	\$34,406	\$25,000	\$25,000
\$1,837,553	\$1,941,920	\$586,428	\$0	TOTL		\$2,093,859	\$2,094,348	\$2,110,585
\$1,837,553	\$1,941,920	\$586,428	\$0	TOTAL FOR ACTIVITY	1100	\$2,093,859	\$2,094,348	\$2,110,585
\$1,837,553	\$1,941,920	\$586,428	\$0	TOTAL FOR ORGANIZATION	0030	\$2,093,859	\$2,094,348	\$2,110,585
\$1,837,553	\$1,941,920	\$586,428	\$0	TOTAL FOR AGENCY	003	\$2,093,859	\$2,094,348	\$2,110,585

FUND 010 GENERAL FUND		AGENCY. 004 DISTRICT CLERK		ACTIVITY. 1200 ADMINISTRATION OF JUSTICE		FUNC:		
ORG. 0040 DISTRICT CLERK								
1998	BUDGET AS MODIFIED	EXP THRU 10/22/99	TOTAL EST EXPENDITURE	ACCOUNT NAME	OBJECT	BUDGET REQUEST	*2000 RECOM ENDED	ADOPTED BUDGET
\$852,922	\$933,610	\$203,866	\$0	\$0 SALARIES AND LABOR	0200	\$923,426	\$1,094,867	\$1,097,826
\$76,117	\$74,206	\$23,462	\$0	\$0 TEMPORARY OR PART-TIME	0201	\$28,710	\$28,710	\$28,710
\$10,704	\$12,018	\$2,371	\$0	\$0 LONGEVITY	0250	\$13,543	\$13,444	\$13,444
\$69,494	\$78,056	\$17,255	\$0	\$0 SOCIAL SECURITY	0300	\$73,875	\$86,982	\$87,208
\$86,680	\$111,527	\$22,371	\$0	\$0 RETIREMENT	0400	\$106,225	\$125,072	\$125,398
\$154,700	\$147,000	\$147,000	\$0	\$0 INSURANCE(GROUP)	0500	\$142,800	\$180,000	\$180,000
\$27,514	\$20,594	\$20,594	\$0	\$0 WORKERS COMP/UNEMPLOYMENT	0600	\$29,705	\$22,148	\$22,206
\$2,822	\$3,500	\$1,326	\$0	\$0 TRAVEL REIMB/CONFERENCES	0701	\$4,300	\$4,025	\$4,025
\$21,404	\$72,591	\$810	\$0	\$0 PROPERTY AND EQUIPMENT	1010	\$3,434	\$4,934	\$4,934
\$21,404	\$72,591	\$810	\$0	\$0 CAPITAL ASSETS	1011	\$5,995	\$5,995	\$5,995
\$47,934	\$51,420	\$8,019	\$0	\$0 HARDWARE PURCHASES	1012	\$8,021	\$4,698	\$4,698
\$537	\$500	\$100	\$0	\$0 OFFICE SUPPLIES	1062	\$54,404	\$54,000	\$54,000
\$537	\$500	\$100	\$0	\$0 OTHER RENTALS	3020	\$800	\$800	\$800
\$537	\$500	\$100	\$0	\$0 INFORMATION TECHNOLOGY	LE3021	\$51,768	\$29,500	\$29,500
\$8,463	\$7,848	\$2,389	\$0	\$0 SOFTWARE PURCHASES	3040	\$16,700	\$16,700	\$16,700
\$1,381,769	\$1,586,461	\$450,573	\$0	\$0 FEES AND SERVICES	4010	\$8,065	\$8,065	\$8,065
\$1,381,769	\$1,586,461	\$450,573	\$0	TOTAL	TOTAL	\$1,471,771	\$1,679,940	\$1,683,509
\$1,381,769	\$1,586,461	\$450,573	\$0	TOTAL FOR ACTIVITY	1200	\$1,471,771	\$1,679,940	\$1,683,509
\$1,381,769	\$1,586,461	\$450,573	\$0	TOTAL FOR ORGANIZATION	0040	\$1,471,771	\$1,679,940	\$1,683,509
\$1,381,769	\$1,586,461	\$450,573	\$0	TOTAL FOR AGENCY	004	\$1,471,771	\$1,679,940	\$1,683,509

EXPENSE BUDGET BY OBJECT

FUND. 010 GENERAL FUND		AGENCY: 005 COUNTY AUDITOR		ACTIVITY: 1100 FINANCIAL ADMINISTRATION		FUNC.		
ORG. 0050 COUNTY AUDITOR	BUDGET AS MODIFIED	EXP THRU 10/22/99	TOTAL EST EXPENDITURE	ACCOUNT NAME	OBJECT	BUDGET REQUEST	*2000 RECOM ENDED	ADOPTED BUDGET
\$586,139	\$611,604	\$131,062	\$0	\$0 SALARIES AND LABOR	0200	\$605,688	\$624,659	\$622,885
\$600	\$8,000	\$0	\$0	\$0 TEMPORARY OR PART-TIME	0201	\$8,000	\$8,000	\$8,000
\$8,300	\$8,842	\$1,797	\$0	\$0 LONGEVITY	0250	\$9,012	\$7,842	\$7,842
\$44,069	\$48,077	\$9,884	\$0	\$0 SOCIAL SECURITY	0300	\$47,637	\$48,998	\$48,863
\$59,099	\$68,249	\$14,429	\$0	\$0 RETIREMENT	0400	\$67,617	\$69,575	\$69,380
\$72,800	\$67,200	\$67,200	\$0	\$0 INSURANCE(GROUP)	0500	\$67,200	\$72,000	\$72,000
\$18,477	\$12,767	\$12,767	\$0	\$0 WORKERS COMP/UNEMPLOYMENT0600	0600	\$19,304	\$12,618	\$12,583
\$8,203	\$6,000	\$475	\$0	\$0 TRAVEL REIMB/CONFERENCES 0701	0701	\$4,800	\$4,800	\$4,800
\$1,476	\$14,033	\$232	\$0	\$0 PROPERTY AND EQUIPMENT 1010	1010	\$670	\$670	\$670
\$3,919	\$4,000	\$570	\$0	\$0 OFFICE SUPPLIES 1062	1062	\$4,200	\$4,200	\$4,200
\$106	\$400	\$149	\$0	\$0 OTHER RENTALS 3020	3020	\$850	\$850	\$850
\$0	\$0	\$0	\$0	\$0 INFORMATION TECHNOLOGY LE3021	LE3021	\$7,680	\$7,680	\$7,680
\$0	\$0	\$0	\$0	\$0 FEES AND SERVICES 4010	4010	\$0	\$0	\$0
\$803,188	\$849,172	\$238,565	\$0	TOTAL	TOTAL	\$842,658	\$861,892	\$859,753
\$803,188	\$849,172	\$238,565	\$0	TOTAL FOR ACTIVITY 1100	1100	\$842,658	\$861,892	\$859,753
\$803,188	\$849,172	\$238,565	\$0	TOTAL FOR ORGANIZATION 0050	0050	\$842,658	\$861,892	\$859,753
\$803,188	\$849,172	\$238,565	\$0	TOTAL FOR AGENCY 005	005	\$842,658	\$861,892	\$859,753

EXPENSE BUDGET BY OBJECT

FUND. 010 GENERAL FUND
 ORG 0060 COUNTY TREASURER
 AGENCY: 006 COUNTY TREASURER
 ACTIVITY: 1100 FINANCIAL ADMINISTRATION
 FUNC.

1998 BUDGET AS MODIFIED	1999 EXP THRU 10/22/99	TOTAL EST EXPENDITURE	ACCOUNT NAME	OBJECT	BUDGET REQUEST	RECOM ENDED	ADOPTED BUDGET
\$248,853	\$61,054	\$0	\$0 SALARIES AND LABOR	0200	\$286,872	\$274,446	\$274,370
\$5,573	\$787	\$0	\$0 TEMPORARY OR PART-TIME	0201	\$0	\$6,264	\$6,264
\$4,027	\$914	\$0	\$0 LONGEVITY	0250	\$4,587	\$4,587	\$4,587
\$19,064	\$4,654	\$0	\$0 SOCIAL SECURITY	0300	\$22,297	\$21,825	\$21,819
\$25,133	\$6,729	\$0	\$0 RETIREMENT	0400	\$32,061	\$31,383	\$31,374
\$31,850	\$29,400	\$0	\$0 INSURANCE(GROUP)	0500	\$33,600	\$31,500	\$31,500
\$7,765	\$5,285	\$0	\$0 WORKERS COMP/UNEMPLOYMENT0600	0600	\$5,907	\$5,367	\$5,366
\$3,536	\$61	\$0	\$0 TRAVEL REIMB/CONFERENCES	0701	\$4,300	\$3,080	\$3,080
\$2,681	\$952	\$0	\$0 PROPERTY AND EQUIPMENT	1010	\$311	\$311	\$311
\$5,999	\$1,204	\$0	\$0 CAPITAL ASSEST	1011	\$1,200	\$0	\$0
\$5,999	\$1,204	\$0	\$0 HARDWARE PURCHASES	1021	\$750	\$0	\$0
\$5,999	\$1,204	\$0	\$0 OFFICE SUPPLIES	1062	\$8,219	\$8,219	\$8,619
\$5,999	\$1,204	\$0	\$0 MATERIALS & SUPPLIES	3000	\$12,596	\$12,096	\$12,096
\$365	\$443	\$0	\$0 OTHER RENTALS	3020	\$499	\$499	\$499
\$365	\$443	\$0	\$0 INFORMATION TECHNOLOGY LE3021	LE3021	\$1,980	\$1,394	\$1,394
\$1,727	\$656	\$0	\$0 SOFTWARE PURCHASES	3040	\$232	\$0	\$0
\$1,727	\$656	\$0	\$0 FEES AND SERVICES	4010	\$158,276	\$158,032	\$158,032
\$376,662	\$115,964	\$0	\$0	TOTL	\$573,687	\$559,003	\$559,311
\$376,662	\$115,964	\$0	\$0 TOTAL FOR ACTIVITY	1100	\$573,687	\$559,003	\$559,311
\$376,662	\$115,964	\$0	\$0 TOTAL FOR ORGANIZATION	0060	\$573,687	\$559,003	\$559,311
\$376,662	\$115,964	\$0	\$0 TOTAL FOR AGENCY	006	\$573,687	\$559,003	\$559,311

EXPENSE BUDGET BY OBJECT

FUND. 010 GENERAL FUND	AGENCY: 007 HUMAN RESOURCES	ACCOUNT NAME	OBJECT	FUNC
ORG. 0070 HUMAN RESOURCES	ACTIVITY. 1000 GENERAL ADMINISTRATION			
1998 BUDGET AS MODIFIED	EXP THRU 10/22/99	TOTAL EST EXPENDITURE		
\$189,088	\$42,412	\$236,785	BUDGET REQUEST	ADOPTED BUDGET
			\$241,059	\$240,777
\$189,088	\$42,412	\$0	\$9,360	\$9,360
\$920	\$181	\$0	\$1,321	\$1,321
\$13,627	\$3,157	\$0	\$19,258	\$19,258
\$18,891	\$4,623	\$0	\$27,691	\$27,660
\$27,300	\$25,200	\$0	\$31,500	\$31,500
\$6,084	\$4,239	\$0	\$4,959	\$4,954
\$4,810	\$2,167	\$0	\$7,500	\$7,500
\$2,105	\$969	\$0	\$900	\$900
\$8,842	\$2,231	\$0	\$2,000	\$2,000
\$8,842	\$2,231	\$0	\$4,791	\$4,791
\$8,842	\$2,231	\$0	\$14,040	\$14,040
\$0	\$1,919	\$0	\$1,923	\$1,923
\$56,441	\$8,240	\$0	\$1,440	\$1,440
\$56,441	\$8,240	\$0	\$300	\$300
\$56,441	\$8,240	\$0	\$53,000	\$53,000
\$647,762	\$158,692	\$0	\$421,042	\$420,702
\$647,762	\$158,692	\$0	\$421,042	\$420,702
\$647,762	\$158,692	\$0	\$421,042	\$420,702
\$647,762	\$158,692	\$0	\$421,042	\$420,702

FUND	010	GENERAL FUND	AGENCY	008	BUILDING MAINTENANCE	ACTIVITY	1000	GENERAL ADMINISTRATION	FUNC.
ORG	0080	BUILDING MAINTENANCE							
			BUDGET	1999	EXP THRU	TOTAL EST	ACCOUNT NAME	OBJECT	BUDGET
			AS MODIFIED	10/22/99	EXPENDITURE			0200	REQUEST
			\$175,924	\$37,646			\$0 SALARIES AND LABOR		\$197,864
			\$5,000	\$1,112			\$0 TEMPORARY OR PART-TIME	0201	\$5,000
			\$3,353	\$698			\$0 LONGEVITY	0250	\$3,711
			\$14,098	\$2,989			\$0 SOCIAL SECURITY	0300	\$15,804
			\$19,721	\$4,166			\$0 RETIREMENT	0400	\$22,173
			\$25,200	\$25,200			\$0 INSURANCE(GROUP)	0500	\$29,400
			\$3,752	\$3,752			\$0 WORKERS COMP/UNEMPLOYMENT0600		\$6,423
			\$0	\$0			\$0 TRAVEL ALLOWANCE	0700	\$0
			\$500	\$0			\$0 TRAVEL REIMB/CONFERENCES 0701		\$0
			\$0	\$0			\$0 PROPERTY AND EQUIPMENT	1010	\$0
			\$0	\$0			\$0 CAPITAL ASSETS	1011	\$0
			\$0	\$0			\$0 REPAIRS TO EQUIPMENT	1020	\$0
			\$500	\$40			\$0 OFFICE SUPPLIES	1062	\$250
			\$600,000	\$70,027			\$0 UTILITIES	2000	\$550,000
			\$26,500	\$5,648			\$0 JANITORIAL AND PEST CONTR2060		\$30,000
			\$3,500	\$453			\$0 OTHER RENTALS	3020	\$3,750
			\$3,500	\$453			\$0 INFORMATION TECHNOLOGY LE3021		\$540
			\$203,828	\$35,567			\$0 OTHER FEES AND SERVICES	4010	\$270,675
			\$25,175	\$5,760			\$0 AUTOMOBILE	6025	\$0
			\$25,175	\$5,760			\$0 REPAIRS-BUILDINGS	7012	\$30,000
			\$4,000	\$814			\$0 SHOP SUPPLIES	9001	\$4,000
			\$1,139,726	\$200,085			TOTAL		\$1,169,590
									\$1,148,801

** FORT BEND COUNTY **
 EXPENSE BUDGET BY OBJECT

FUND	010 GENERAL FUND	AGENCY:	008 BUILDING MAINTENANCE	FUNC.					
ORG	0080 BUILDING MAINTENANCE	ACTIVITY:	1000 GENERAL ADMINISTRATION						
1998	BUDGET AS MODIFIED	1999	EXP THRU 10/22/99	TOTAL EST EXPENDITURE	ACCOUNT NAME	OBJECT	BUDGET REQUEST	RECOM ENDED	ADOPTED BUDGET
\$960,619	\$1,139,726	\$200,085	\$200,085	\$0	TOTAL FOR ACTIVITY	1000	\$1,169,590	\$1,148,705	\$1,148,801
\$960,619	\$1,139,726	\$200,085	\$200,085	\$0	TOTAL FOR ORGANIZATION	0080	\$1,169,590	\$1,148,705	\$1,148,801
\$960,619	\$1,139,726	\$200,085	\$200,085	\$0	TOTAL FOR AGENCY	008	\$1,169,590	\$1,148,705	\$1,148,801

EXPENSE BUDGET BY OBJECT

FUND. 010 GENERAL FUND
 ORG. 0090 JUVENILE DETENTION OPERATING
 AGENCY: 009 JUVENILE DETENTION
 ACTIVITY. 1200 ADMINISTRATION OF JUSTICE

BUDGET AS MODIFIED	EXP THRU 10/22/99	TOTAL EST EXPENDITURE	ACCOUNT NAME	OBJECT	BUDGET REQUEST	RECOM ENDED	ADOPTED BUDGET
\$665,670	\$781,720	\$161,229	\$0 SALARIES AND LABOR	0200	\$968,039	\$875,877	\$876,034
\$65,703	\$60,000	\$10,551	\$0 TEMPORARY OR PART-TIME	0201	\$90,000	\$90,000	\$90,000
\$6,397	\$8,343	\$1,544	\$0 LONGEVITY	0250	\$9,363	\$9,363	\$9,363
\$55,516	\$65,030	\$13,165	\$0 SOCIAL SECURITY	0300	\$81,656	\$74,496	\$74,508
\$70,736	\$86,907	\$18,484	\$0 RETIREMENT	0400	\$114,664	\$103,819	\$103,836
\$136,500	\$134,400	\$134,400	\$0 INSURANCE(GROUP)	0500	\$168,000	\$148,500	\$148,500
\$23,822	\$17,325	\$17,325	\$0 WORKERS COMP./UNEMPLOYMENT	0600	\$33,090	\$19,148	\$19,187
\$3,863	\$9,425	\$0	\$0 TRAVEL REIMB./CONFERENCES	0701	\$14,400	\$9,425	\$9,425
\$23,836	\$0	\$0	\$0 PROPERTY AND EQUIPMENT	1010	\$9,145	\$5,500	\$5,500
\$23,836	\$0	\$0	\$0 HARDWARE PURCHASES	1012	\$1,245	\$390	\$390
\$3,820	\$4,750	\$144	\$0 OFFICE SUPPLIES	1062	\$4,750	\$4,750	\$4,750
\$61,146	\$70,000	\$8,686	\$0 UTILITIES	2000	\$77,000	\$66,400	\$66,400
\$74,220	\$80,000	\$17,190	\$0 GROCERIES	2030	\$88,000	\$85,000	\$85,000
\$5,997	\$8,000	\$3,340	\$0 CLOTHING/BEDDING/LAUNDRY	2040	\$8,000	\$8,000	\$8,000
\$15,181	\$15,000	\$558	\$0 MEDICAL SERVICES/MEDICINE	2050	\$20,000	\$15,000	\$15,000
\$24,811	\$25,000	\$5,353	\$0 SUPPLIES AND OPERATING	EX2080	\$33,000	\$22,000	\$22,000
\$1,543	\$2,000	\$136	\$0 OTHER RENTALS	3020	\$2,000	\$2,000	\$2,000
\$1,543	\$2,000	\$136	\$0 INFORMATION TECHNOLOGY	LE3021	\$1,503	\$1,445	\$1,445
\$0	\$0	\$0	\$0 SOFTWARE PURCHASES	3040	\$284	\$284	\$284
\$0	\$0	\$0	\$0 FEES AND SERVICES	4010	\$0	\$0	\$0
\$1,771	\$2,000	\$0	\$0 UNIFORMS	4011	\$4,400	\$2,200	\$2,200
\$6,694	\$10,000	\$195	\$0 REPAIRS-BUILDINGS	7012	\$17,500	\$18,000	\$18,000
\$1,272,605	\$1,381,900	\$392,436	\$0	TOTL	\$1,746,039	\$1,561,597	\$1,561,622

FUND: 010 GENERAL FUND	AGENCY: 009 JUVENILE DETENTION	FUNC
ORG. 0090 JUVENILE DETENTION OPERATING	ACTIVITY: 1200 ADMINISTRATION OF JUSTICE	
1998 BUDGET AS MODIFIED	ACCOUNT NAME	BUDGET REQUEST
EXPENDITURE	OBJECT	2000 RECOM ENDED
		ADOPTED BUDGET
\$1,272,605	TOTAL FOR ACTIVITY 1200	\$1,746,039
\$1,272,605	TOTAL FOR ORGANIZATION 0090	\$1,746,039
\$1,272,605	TOTAL FOR AGENCY 009	\$1,746,039

FUND	010	GENERAL FUND	AGENCY. 010	240TH DISTRICT COURT	AGENCY. 1200	ADMINISTRATION OF JUSTICE	FUNC.		
ORG.	0100	240TH DISTRICT COURT	1998	BUDGET AS MODIFIED	EXP THRU 10/22/99	TOTAL EST EXPENDITURE	BUDGET REQUEST	RECOM ENDED	ADOPTED BUDGET
			\$96,863	\$99,839	\$21,922	\$0	\$99,910	\$104,910	\$104,227
			\$2,884	\$2,500	\$200	\$0	\$2,500	\$2,500	\$2,500
			\$2,372	\$2,456	\$519	\$0	\$2,575	\$2,575	\$2,575
			\$7,249	\$8,413	\$1,559	\$0	\$8,135	\$8,708	\$8,678
			\$10,171	\$11,822	\$2,526	\$0	\$11,698	\$12,246	\$12,204
			\$13,650	\$12,600	\$12,600	\$0	\$12,600	\$13,500	\$13,500
			\$3,093	\$2,144	\$2,144	\$0	\$3,157	\$2,147	\$2,140
			\$3,101	\$3,856	\$800	\$0	\$3,856	\$3,840	\$3,840
			\$1,326	\$1,500	\$0	\$0	\$1,500	\$1,500	\$1,500
			\$0	\$3,068	\$0	\$0	\$0	\$0	\$0
			\$3,209	\$3,000	\$1,095	\$0	\$3,000	\$3,000	\$3,000
			\$0	\$1,000	\$0	\$0	\$1,000	\$1,000	\$1,000
			\$707	\$1,423	\$43	\$0	\$1,423	\$1,000	\$1,000
			\$707	\$1,423	\$43	\$0	\$480	\$480	\$480
			\$111,948	\$200,000	\$8,050	\$0	\$200,000	\$200,000	\$200,000
			\$1,960	\$2,500	\$970	\$0	\$2,500	\$2,500	\$2,500
			\$0	\$0	\$0	\$0	\$0	\$0	\$0
			\$0	\$0	\$0	\$0	\$0	\$0	\$0
			\$259,240	\$357,544	\$52,471	\$0	\$354,334	\$359,906	\$359,144
			\$259,240	\$357,544	\$52,471	\$0	\$354,334	\$359,906	\$359,144
			\$259,240	\$357,544	\$52,471	\$0	\$354,334	\$359,906	\$359,144
			\$259,240	\$357,544	\$52,471	\$0	\$354,334	\$359,906	\$359,144

FUND	010	GENERAL FUND	AGENCY. 011 268TH DISTRICT COURT	ACTIVITY. 1200 ADMINISTRATION OF JUSTICE	FUNC			
ORG	0110	268TH DISTRICT COURT						
1998	BUDGET	1999	TOTAL EST	ACCOUNT NAME	OBJECT	BUDGET	RECOM	ADOPTED
EXPENDITURE	AS MODIFIED	EXP THRU	EXPENDITURE			REQUEST	ENDED	BUDGET
\$96,863	\$99,839	10/22/99	\$21,922	\$0 SALARIES AND LABOR	0200	\$99,839	\$104,910	\$104,227
\$1,110	\$1,600	\$720	\$720	\$0 TEMPORARY OR PART-TIME	0201	\$1,600	\$1,600	\$1,600
\$2,492	\$3,204	\$543	\$543	\$0 LONGEVITY	0250	\$2,693	\$2,693	\$2,693
\$7,122	\$8,301	\$1,624	\$1,624	\$0 SOCIAL SECURITY	0300	\$8,314	\$8,648	\$8,619
\$10,183	\$11,759	\$2,572	\$2,572	\$0 RETIREMENT	0400	\$11,779	\$12,259	\$12,217
\$13,650	\$12,600	\$12,600	\$12,600	\$0 INSURANCE(GROUP)	0500	\$12,600	\$13,500	\$13,500
\$3,032	\$2,116	\$2,116	\$2,116	\$0 WORKERS COMP/UNEMPLOYMENT0600		\$3,229	\$2,132	\$2,125
\$3,101	\$3,856	\$800	\$800	\$0 TRAVEL ALLOWANCE	0700	\$3,856	\$3,840	\$3,840
\$1,688	\$3,000	\$941	\$941	\$0 TRAVEL REIMS/CONFERENCES	0701	\$5,000	\$4,600	\$4,600
\$0	\$4,995	\$4,995	\$4,995	\$0 PROPERTY AND EQUIPMENT	1010	\$500	\$500	\$500
\$9,612	\$1,004	\$184	\$184	\$0 OFFICE SUPPLIES	1062	\$1,600	\$1,600	\$1,600
\$0	\$10,000	\$462	\$462	\$0 LAW BOOKS	1063	\$10,000	\$10,000	\$10,000
\$560	\$1,000	\$62	\$62	\$0 OTHER RENTALS	3020	\$1,000	\$0	\$0
\$2,365	\$2,500	\$30	\$30	\$0 INFORMATION TECHNOLOGY	1E3021	\$480	\$480	\$480
\$2,365	\$2,500	\$30	\$30	\$0 SOFTWARE PURCHASES	3040	\$284	\$284	\$284
\$157,923	\$200,000	\$10,050	\$10,050	\$0 FEES AND SERVICES	4010	\$250,000	\$250,000	\$250,000
\$2,365	\$2,500	\$30	\$30	\$0 GRAND JURY BAILIFF	4090	\$2,500	\$2,500	\$2,500
\$0	\$0	\$0	\$0	\$0 SPECIAL DISTRICT JUDGES	4100	\$0	\$0	\$0
\$314,431	\$370,774	\$59,681	\$59,681	\$0	TOTL	\$415,274	\$419,546	\$418,785
\$314,431	\$370,774	\$59,681	\$59,681	\$0	TOTAL FOR ACTIVITY	\$415,274	\$419,546	\$418,785
\$314,431	\$370,774	\$59,681	\$59,681	\$0	TOTAL FOR ORGANIZATION	\$415,274	\$419,546	\$418,785
\$314,431	\$370,774	\$59,681	\$59,681	\$0	TOTAL FOR AGENCY	\$415,274	\$419,546	\$418,785

FUND. 010 GENERAL FUND		AGENCY: 012 DISTRICT ATTORNEY		ACTIVITY: 1200 ADMINISTRATION OF JUSTICE		FUNC.		
ORG. 0120 DISTRICT ATTORNEY								
1998	BUDGET AS MODIFIED	1999	TOTAL EST	ACCOUNT NAME	OBJECT	BUDGET REQUEST	RECOM ENDED	ADOPTED BUDGET
EXPENDITURE	10/22/99	EXP THRU	EXPENDITURE					
\$1,841,685	\$2,105,982	10/22/99	\$444,625	\$0 SALARIES AND LABOR	0200	\$2,206,532	\$2,246,581	\$2,242,397
\$16,080	\$20,800	\$3,840	\$0	TEMPORARY OR PART-TIME	0201	\$37,440	\$16,640	\$16,640
\$15,324	\$17,356	\$3,517	\$0	LONGEVITY	0250	\$21,236	\$20,604	\$20,604
\$139,142	\$164,259	\$34,032	\$0	SOCIAL SECURITY	0300	\$173,289	\$174,863	\$174,543
\$185,173	\$233,901	\$48,700	\$0	RETIREMENT	0400	\$246,886	\$251,437	\$250,977
\$227,500	\$231,000	\$231,000	\$0	INSURANCE(GROUP)	0500	\$243,600	\$252,000	\$252,000
\$55,971	\$43,709	\$43,709	\$0	WORKERS COMP/UNEMPLOYMENT	0600	\$70,153	\$44,896	\$44,814
\$7,085	\$1,966	\$914	\$0	TRAVEL ALLOWANCE	0700	\$1,966	\$1,966	\$1,966
\$25,983	\$27,000	\$2,612	\$0	TRAVEL REIMB/CONFERENCES	0701	\$35,140	\$28,850	\$28,850
\$13,530	\$63,549	\$7,542	\$0	PROPERTY AND EQUIPMENT	1010	\$10,728	\$8,476	\$8,476
\$13,530	\$63,549	\$7,542	\$0	CAPITAL ASSETS	1011	\$0	\$5,995	\$5,995
\$21,055	\$26,100	\$5,218	\$0	HARDWARE PURCHASES	1012	\$29,092	\$8,892	\$8,892
\$21,055	\$26,100	\$5,218	\$0	OFFICE SUPPLIES	1062	\$27,000	\$24,500	\$24,500
\$15,167	\$9,720	\$1,110	\$0	LAW BOOKS	1063	\$15,000	\$15,000	\$15,000
\$716	\$3,800	\$598	\$0	OTHER RENTALS	3020	\$16,050	\$16,050	\$16,050
\$41	\$600	\$64	\$0	INFORMATION TECHNOLOGY	LE3021	\$22,560	\$25,034	\$25,034
\$41	\$600	\$64	\$0	SOFTWARE PURCHASES	3040	\$9,675	\$8,975	\$8,975
\$11,957	\$11,000	\$6,284	\$0	FEES AND SERVICES	4010	\$26,890	\$20,000	\$20,000
\$41	\$600	\$64	\$0	SPECIAL CRIMINAL INVESTIG	4012	\$0	\$0	\$0
\$0	\$0	\$0	\$0	EDUCATION EXPENSE	4014	\$0	\$0	\$0
\$0	\$18,900	\$0	\$0	AUTOMOBILES	6025	\$21,000	\$0	\$0
\$0	\$0	\$0	\$0	REPAIRS & MAINT/RADIOS	7020	\$0	\$0	\$0
\$2,611,076	\$3,070,491	\$846,653	\$0	TOTL		\$3,214,237	\$3,170,759	\$3,165,713

EXPENSE BUDGET BY OBJECT

FUND	010	GENERAL FUND	AGENCY:	012	DISTRICT ATTORNEY	ACTIVITY:	1200	ADMINISTRATION OF JUSTICE	FUNC.			
ORG.	0120	DISTRICT ATTORNEY										
1998	BUDGET	AS MODIFIED	1999	EXP THRU	10/22/99	TOTAL EST	EXPENDITURE	ACCOUNT NAME	OBJECT	BUDGET	RECOM	ADOPTED
EXPENDITURE	AS MODIFIED	EXP THRU	10/22/99	EXPENDITURE	TOTAL EST	EXPENDITURE	EXPENDITURE	ACCOUNT NAME	OBJECT	REQUEST	ENDED	BUDGET
\$2,611,076	\$3,070,491	\$846,653	\$0	TOTAL FOR ACTIVITY	1200	\$3,214,237	\$3,170,759			\$3,214,237	\$3,170,759	\$3,165,713
\$2,611,076	\$3,070,491	\$846,653	\$0	TOTAL FOR ORGANIZATION	0120	\$3,214,237	\$3,170,759			\$3,214,237	\$3,170,759	\$3,165,713
\$2,611,076	\$3,070,491	\$846,653	\$0	TOTAL FOR AGENCY	012	\$3,214,237	\$3,170,759			\$3,214,237	\$3,170,759	\$3,165,713

FUND	ORG	GENERAL FUND	DISTRICT COURT	AGENCY:	013 328TH DISTRICT COURT	ACTIVITY:	1200 ADMINISTRATION OF JUSTICE	ACCOUNT NAME	OBJECT	BUDGET REQUEST	*2000 RECOM ENDED	ADOPTED BUDGET											
1998		BUDGET AS MODIFIED	EXP THRU 10/22/99	TOTAL EST EXPENDITURE	\$0 SALARIES AND LABOR	\$0 TEMPORARY OR PART-TIME	\$0 LONGEVITY	\$0 SOCIAL SECURITY	\$0 RETIREMENT	\$0 INSURANCE(GROUP)	\$0 WORKERS COMP/UNEMPLOYMENT	\$0 TRAVEL ALLOWANCE	\$0 TRAVEL REIMB/CONFERENCES	\$0 PROPERTY AND EQUIPMENT	\$0 CAPITAL ASSETS	\$0 OFFICE SUPPLIES	\$0 OTHER RENTALS	\$0 I I LEASES	\$0 FEES AND SERVICES	TOTAL	TOTAL FOR ACTIVITY	TOTAL FOR ORGANIZATION	TOTAL FOR AGENCY
\$168,662	\$173,734	\$173,734	\$38,001	\$174,778	0200	0201	0250	0300	0400	0500	0600	0700	0701	1010	1011	1062	3020	3021	4010	\$411,135	\$413,411	\$413,411	\$413,411
\$13,940	\$15,000	\$15,000	\$6,960	\$15,000																\$15,000	\$15,000		\$15,000
\$2,280	\$3,399	\$3,399	\$517	\$3,399																\$3,636	\$2,601		\$2,601
\$13,600	\$14,366	\$14,366	\$3,388	\$15,091																\$15,091	\$15,685		\$15,572
\$17,302	\$19,777	\$19,777	\$4,270	\$20,050																\$20,050	\$20,904		\$20,741
\$18,200	\$16,800	\$16,800	\$16,800	\$16,800																\$16,800	\$18,000		\$18,000
\$5,517	\$3,733	\$3,733	\$3,733	\$5,828																\$5,828	\$3,944		\$3,915
\$3,101	\$3,856	\$3,856	\$800	\$3,856																\$3,856	\$3,840		\$3,840
\$7,526	\$7,512	\$7,512	\$1,658	\$7,512																\$7,512	\$7,512		\$7,512
\$195	\$5,664	\$5,664	\$254	\$5,664																\$5,664	\$5,664		\$5,664
\$195	\$5,664	\$5,664	\$254	\$2,500																\$2,500	\$0		\$0
\$3,611	\$8,635	\$8,635	\$169	\$8,635																\$8,635	\$5,000		\$5,000
\$0	\$1,185	\$1,185	\$86	\$1,185																\$1,185	\$535		\$535
\$0	\$1,185	\$1,185	\$86	\$0																\$0	\$480		\$480
\$167,023	\$130,600	\$130,600	\$19,949	\$130,600																\$130,600	\$130,650		\$130,650
\$421,152	\$411,110	\$411,110	\$96,925	\$411,135																\$411,135	\$413,411		\$411,627
\$421,152	\$411,110	\$411,110	\$96,925	\$411,135																\$411,135	\$413,411		\$411,627
\$421,152	\$411,110	\$411,110	\$96,925	\$411,135																\$411,135	\$413,411		\$411,627
\$421,152	\$411,110	\$411,110	\$96,925	\$411,135																\$411,135	\$413,411		\$411,627

FUND. 010 GENERAL FUND
 ORG. 0140 CHILD SUPPORT
 AGENCY. 014 CHILD SUPPORT
 ACTIVITY: 1200 ADMINISTRATION OF JUSTICE
 FUNC:

1998 BUDGET AS MODIFIED	1999 EXP THRU 10/22/99	TOTAL EST EXPENDITURE	ACCOUNT NAME	OBJECT	BUDGET REQUEST	2000 RECOM ENDED	ADOPTED BUDGET
\$130,296	\$37,547	\$0	\$0 SALARIES AND LABOR	0200	\$184,369	\$193,587	\$192,623
\$5,299	\$0	\$0	\$0 TEMPORARY OR PART-TIME	0201	\$0	\$0	\$0
\$1,308	\$310	\$0	\$0 LONGEVITY	0250	\$2,045	\$2,045	\$2,045
\$9,794	\$2,714	\$0	\$0 SOCIAL SECURITY	0300	\$14,261	\$14,966	\$14,892
\$12,998	\$4,110	\$0	\$0 RETIREMENT	0400	\$20,506	\$21,520	\$21,514
\$27,300	\$29,400	\$0	\$0 INSURANCE(GROUP)	0500	\$29,400	\$31,500	\$31,500
\$4,045	\$3,245	\$0	\$0 WORKERS COMP/UNEMPLOYMENT0600	0600	\$5,779	\$3,854	\$3,835
\$0	\$0	\$0	\$0 TRAVEL ALLOWANCE	0700	\$0	\$0	\$0
\$511	\$85	\$0	\$0 TRAVEL REIMB/CONFERENCES	0701	\$3,800	\$2,200	\$2,200
\$1,949	\$2,844	\$0	\$0 PROPERTY AND EQUIPMENT	1010	\$1,320	\$1,320	\$1,320
\$49,917	\$2,560	\$0	\$0 CAPITAL ASSETS	1011	\$7,210	\$5,210	\$5,210
\$49,917	\$2,560	\$0	\$0 OFFICE SUPPLIES	1062	\$53,000	\$50,000	\$50,000
\$4,842	\$822	\$0	\$0 UTILITIES	2000	\$7,800	\$7,800	\$7,800
\$310	\$0	\$0	\$0 OTHER RENTALS	3020	\$300	\$300	\$300
\$310	\$0	\$0	\$0 INFORMATION TECHNOLOGY LE3021	3021	\$1,920	\$1,920	\$1,920
\$310	\$0	\$0	\$0 OTHER FEES AND SERVICES	4010	\$742	\$742	\$742
\$299,106	\$86,197	\$0	TOTAL	TOTAL	\$332,452	\$336,964	\$335,901
\$299,106	\$86,197	\$0	TOTAL FOR ACTIVITY	1200	\$332,452	\$336,964	\$335,901
\$299,106	\$86,197	\$0	TOTAL FOR ORGANIZATION	0140	\$332,452	\$336,964	\$335,901
\$299,106	\$86,197	\$0	TOTAL FOR AGENCY	014	\$332,452	\$336,964	\$335,901

FUND. 010 GENERAL FUND		AGENCY: 015 COUNTY COURT-AT-LAW 1		ACTIVITY: 1200 ADMINISTRATION OF JUSTICE		FUNC	
ORG 0150 COUNTY COURT AT LAW #1		TOTAL EST		BUDGET REQUEST		RECOM ENDED	
1998	BUDGET AS MODIFIED	1999	EXP THRU 10/22/99	EXPENDITURE	OBJECT	2000	ADPTED BUDGET
\$225,579	\$234,804	\$55,537	\$55,537	\$0	0200	\$246,318	\$245,935
\$360	\$500	\$0	\$0	\$0	0201	\$500	\$500
\$1,974	\$2,229	\$459	\$459	\$0	0250	\$2,443	\$2,443
\$14,854	\$18,452	\$4,259	\$4,259	\$0	0300	\$18,571	\$19,333
\$22,919	\$26,477	\$6,164	\$6,164	\$0	0400	\$27,072	\$27,744
\$18,200	\$16,800	\$16,800	\$16,800	\$0	0500	\$16,800	\$18,000
\$6,607	\$4,468	\$4,468	\$4,468	\$0	0600	\$7,139	\$4,508
\$3,101	\$3,856	\$800	\$800	\$0	0700	\$3,856	\$3,840
\$839	\$4,000	\$414	\$414	\$0	0701	\$4,600	\$4,600
\$1,397	\$231	\$231	\$231	\$0	1010	\$0	\$0
\$5,876	\$4,108	\$222	\$222	\$0	1062	\$4,000	\$4,000
\$0	\$2,292	\$218	\$218	\$0	1063	\$3,500	\$3,500
\$565	\$550	\$74	\$74	\$0	3020	\$960	\$0
\$565	\$550	\$74	\$74	\$0	3021	\$0	\$960
\$127,384	\$101,300	\$20,357	\$20,357	\$0	4010	\$101,300	\$101,300
\$430,220	\$420,617	\$110,077	\$110,077	\$0	TOTL	\$430,551	\$436,655
\$430,220	\$420,617	\$110,077	\$110,077	\$0	TOTAL FOR ACTIVITY 1200	\$430,551	\$436,655
\$430,220	\$420,617	\$110,077	\$110,077	\$0	TOTAL FOR ORGANIZATION 0150	\$430,551	\$436,655
\$430,220	\$420,617	\$110,077	\$110,077	\$0	TOTAL FOR AGENCY 015	\$430,551	\$436,655

EXPENSE BUDGET BY OBJECT

FUND	010	GENERAL FUND	AGENCY, 016 JUVENILE BOARD	1200	ADMINISTRATION OF JUSTICE	FUNC		
ORG:	0160	JUVENILE BOARD & JUDGES	ACTIVITY, 1200 ADMINISTRATION OF JUSTICE					
1998	BUDGET AS MODIFIED	1999	TOTAL EST	ACCOUNT NAME	OBJECT	BUDGET REQUEST	*2000 RECOM ENDED	ADOPTED BUDGET
\$17,676	\$18,496	\$3,847	\$0	SALARIES AND LABOR	0200	\$18,496	\$18,540	\$18,540
\$603	\$1,415	\$141	\$0	SOCIAL SECURITY	0300	\$1,415	\$554	\$554
\$1,756	\$2,035	\$417	\$0	RETIREMENT	0400	\$2,035	\$2,040	\$2,040
\$0	\$0	\$0	\$0	WORKERS COMP/UNEMPLOYMENT	0600	\$0	\$0	\$0
\$20,035	\$21,946	\$4,405	\$0	TOTAL		\$21,946	\$21,134	\$21,134
\$20,035	\$21,946	\$4,405	\$0	TOTAL FOR ACTIVITY	1200	\$21,946	\$21,134	\$21,134
\$20,035	\$21,946	\$4,405	\$0	TOTAL FOR ORGANIZATION	0160	\$21,946	\$21,134	\$21,134
\$20,035	\$21,946	\$4,405	\$0	TOTAL FOR AGENCY	016	\$21,946	\$21,134	\$21,134

** FORT ORIN COUNTY **
 EXPENSE BUDGET BY OBJECT

FUND. 010 GENERAL FUND AGENCY. 017 ADULT PROBATION
 ORG. 0170 ADULT PROBATION OPERATING ACTIVITY: 1200 ADMINISTRATION OF JUSTICE FUNC.

1998	BUDGET AS MODIFIED	EXP THRU 10/22/99	TOTAL EST EXPENDITURE	ACCOUNT NAME	OBJECT	BUDGET REQUEST	RECOM ENDED	ADOPTED BUDGET
\$25,213	\$18,720	\$0	\$0	\$0 PROPERTY AND EQUIPMENT	1010	\$25,131	\$21,543	\$21,543
\$25,213	\$18,720	\$0	\$0	\$0 HARDWARE PURCHASES	1012	\$9,100	\$9,100	\$9,100
\$4,499	\$4,500	\$390	\$0	\$0 REPAIRS TO EQUIPMENT	1020	\$4,500	\$4,500	\$4,500
\$198	\$1,800	\$0	\$0	\$0 OFFICE SUPPLIES	1062	\$1,000	\$1,000	\$1,000
\$43,366	\$61,000	\$7,500	\$0	\$0 UTILITIES	2000	\$23,000	\$23,000	\$23,000
\$704	\$8,450	\$507	\$0	\$0 OTHER RENTALS	3020	\$9,000	\$9,000	\$9,000
\$704	\$8,450	\$507	\$0	\$0 INFORMATION TECHNOLOGY LE3021		\$960	\$960	\$960
\$0	\$8,000	\$0	\$0	\$0 FEES AND SERVICES	4010	\$10,300	\$10,300	\$10,300
\$246	\$500	\$0	\$0	\$0 UNIFORMS	4011	\$500	\$500	\$500
\$100,143	\$130,140	\$8,904	\$0	TOTAL	TOTAL	\$83,491	\$79,903	\$79,903
\$100,143	\$130,140	\$8,904	\$0	TOTAL FOR ACTIVITY	1200	\$83,491	\$79,903	\$79,903
\$100,143	\$130,140	\$8,904	\$0	TOTAL FOR ORGANIZATION	0170	\$83,491	\$79,903	\$79,903
\$100,143	\$130,140	\$8,904	\$0	TOTAL FOR AGENCY	017	\$83,491	\$79,903	\$79,903

EXPENSE BUDGET BY OBJECT

FUND	010	GENERAL FUND	AGENCY.	019	JUSTICE OF THE PEACE PCT1 PL2	ACTIVITY.	1200	ADMINISTRATION OF JUSTICE	FUNC.
ORG	0190	JUSTICE OF THE PEACE PCT1 PL2	EXPENDITURE	AS MODIFIED	10/22/99	EXPENDITURE	AS MODIFIED	10/22/99	EXPENDITURE
\$149,875	\$2,000	\$633	\$37,443	\$164,592	\$2,000	\$633	\$164,592	\$185,009	\$197,884
\$2,473	\$2,721	\$570	\$570	\$2,721	\$2,721	\$570	\$2,721	\$3,067	\$3,067
\$11,008	\$12,952	\$2,818	\$2,818	\$12,952	\$12,952	\$2,818	\$12,952	\$14,541	\$15,373
\$15,140	\$18,404	\$4,128	\$4,128	\$18,404	\$18,404	\$4,128	\$18,404	\$20,689	\$22,105
\$22,750	\$21,000	\$21,000	\$21,000	\$21,000	\$21,000	\$21,000	\$21,000	\$25,200	\$27,000
\$4,525	\$3,258	\$3,258	\$3,258	\$3,258	\$3,258	\$3,258	\$3,258	\$5,694	\$3,742
\$0	\$0	\$0	\$0	\$0	\$0	\$0	\$0	\$0	\$0
\$872	\$3,000	\$346	\$346	\$3,000	\$3,000	\$346	\$3,000	\$3,000	\$3,000
\$1,530	\$8,007	\$2,801	\$2,801	\$8,007	\$8,007	\$2,801	\$8,007	\$3,000	\$3,000
\$4,183	\$4,662	\$730	\$730	\$4,662	\$4,662	\$730	\$4,662	\$5,000	\$5,000
\$87	\$787	\$21	\$21	\$787	\$787	\$21	\$787	\$1,530	\$1,530
\$383	\$828	\$39	\$39	\$828	\$828	\$39	\$828	\$960	\$480
\$383	\$828	\$39	\$39	\$828	\$828	\$39	\$828	\$300	\$300
\$213,482	\$243,039	\$73,826	\$73,826	\$243,039	\$243,039	\$73,826	\$243,039	\$269,990	\$282,481
\$213,482	\$243,039	\$73,826	\$73,826	\$243,039	\$243,039	\$73,826	\$243,039	\$269,990	\$282,481
\$213,482	\$243,039	\$73,826	\$73,826	\$243,039	\$243,039	\$73,826	\$243,039	\$269,990	\$282,481
\$213,482	\$243,039	\$73,826	\$73,826	\$243,039	\$243,039	\$73,826	\$243,039	\$269,990	\$282,481

FUND	ORG	010	GENERAL FUND	020	JUSTICE OF THE PEACE PCT1 P11	020	ADMINISTRATION OF JUSTICE	ACTIVITY.	1200	ADMINISTRATION OF JUSTICE	FUNC.												
EXPENSE BUDGET BY OBJECT																							
1998	BUDGET	AS MODIFIED	EXP THRU	10/22/99	EXPENDITURE	TOTAL EST	EXPENDITURE	ACCOUNT NAME	OBJECT	BUDGET REQUEST	RECOM ENDED	ADOPTED BUDGET											
\$125,613	\$142,347	\$142,347	\$32,437	\$385	\$5,000	\$2,625	\$11,473	\$15,947	\$16,800	\$2,844	\$0	\$510	\$39	\$1,898	\$8,756	\$12,031	\$387	\$200,270	\$200,270	\$200,270	\$200,270		
	\$4,178	\$5,000	\$385	\$5,000	\$0	TEMPORARY OR PART-TIME	0201	\$5,000	\$5,000	\$142,347	\$150,107	\$5,000	\$5,000										
	\$2,371	\$2,625	\$545	\$545	\$0	LONGEVITY	0250	\$2,862	\$2,862	\$11,491	\$12,085	\$12,085	\$12,085										
	\$9,715	\$11,473	\$2,468	\$3,581	\$0	SOCIAL SECURITY	0300	\$15,973	\$16,827	\$16,800	\$18,000	\$18,000	\$18,000										
	\$12,717	\$15,947	\$3,581	\$16,800	\$0	RETIREMENT	0400	\$4,458	\$2,890	\$4,458	\$2,890	\$2,890	\$2,890										
	\$18,200	\$16,800	\$16,800	\$2,844	\$0	INSURANCE(GROUP)	0500	\$0	\$0	\$0	\$0	\$0	\$0										
	\$3,855	\$2,844	\$2,844	\$0	\$0	WORKERS COMP/UNEMPLOYMENT	0600	\$0	\$0	\$0	\$0	\$0	\$0										
	\$0	\$0	\$0	\$0	\$0	TRAVEL ALLOWANCE	0700	\$750	\$750	\$750	\$750	\$750	\$750										
	\$510	\$1,250	\$0	\$0	\$0	TRAVEL REIMB/CONFERENCES	0701	\$0	\$0	\$0	\$0	\$0	\$0										
	\$39	\$0	\$0	\$0	\$0	PROPERTY AND EQUIPMENT	1010	\$0	\$0	\$0	\$0	\$0	\$0										
	\$1,898	\$2,570	\$100	\$100	\$0	OFFICE SUPPLIES	1062	\$3,000	\$2,500	\$3,000	\$2,500	\$2,500	\$2,500										
	\$8,756	\$10,072	\$1,250	\$4,172	\$0	UTILITIES	2000	\$10,000	\$10,000	\$10,000	\$10,000	\$10,000	\$10,000										
	\$12,031	\$13,145	\$4,172	\$0	\$0	OTHER RENTALS	3020	\$12,700	\$12,700	\$12,700	\$12,700	\$12,700	\$12,700										
	\$387	\$521	\$0	\$0	\$0	OTHER FEES AND SERVICES	4010	\$700	\$700	\$700	\$700	\$700	\$700										
	\$200,270	\$224,594	\$64,582	\$64,582	\$0	TOTAL	TOTL	\$226,081	\$234,421	\$226,081	\$234,421	\$234,421	\$234,421										
	\$200,270	\$224,594	\$64,582	\$64,582	\$0	TOTAL FOR ACTIVITY	1200	\$226,081	\$234,421	\$226,081	\$234,421	\$234,421	\$234,421										
	\$200,270	\$224,594	\$64,582	\$64,582	\$0	TOTAL FOR ORGANIZATION	0200	\$226,081	\$234,421	\$226,081	\$234,421	\$234,421	\$234,421										
	\$200,270	\$224,594	\$64,582	\$64,582	\$0	TOTAL FOR AGENCY	020	\$226,081	\$234,421	\$226,081	\$234,421	\$234,421	\$234,421										

FUND	010	GENERAL FUND	AGENCY: 021	JUSTICE OF THE PEACE 3	ACTIVITY: 1200	ADMINISTRATION OF JUSTICE	FUNC.
ORG	0210	JUSTICE OF THE PEACE #3					
1998	BUDGET	1999	EXP THRU	TOTAL EST	ACCOUNT NAME	OBJECT	
\$142,826	AS MODIFIED	10/22/99	EXPENDITURE	\$0	SALARIES AND LABOR	0200	
		\$160,394	\$36,382	\$0			
\$1,988	\$2,560	\$427	\$0	\$0	LONGEVITY	0250	\$2,417
\$10,937	\$12,466	\$2,788	\$0	\$0	SOCIAL SECURITY	0300	\$12,698
\$14,392	\$17,925	\$3,997	\$0	\$0	RETIREMENT	0400	\$18,259
\$22,750	\$21,000	\$21,000	\$21,000	\$0	INSURANCE(GROUP)	0500	\$21,000
\$4,548	\$3,130	\$3,130	\$3,130	\$0	WORKERS COMP/UNEMPLOYMENT	0600	\$4,951
\$0	\$0	\$0	\$0	\$0	TRAVEL ALLOWANCE	0700	\$0
\$1,806	\$3,000	\$0	\$0	\$0	TRAVEL REIMB/CONFERENCES	0701	\$4,000
\$0	\$600	\$0	\$0	\$0	PROPERTY AND EQUIPMENT	1010	\$900
\$6,935	\$5,571	\$594	\$594	\$0	OFFICE SUPPLIES	1062	\$6,000
\$2,139	\$2,690	\$357	\$357	\$0	UTILITIES	2000	\$2,700
\$892	\$678	\$45	\$45	\$0	OTHER RENTALS	3020	\$500
\$892	\$678	\$45	\$45	\$0	INFORMATION TECHNOLOGY	LE3021	\$2,400
\$70	\$141	\$0	\$0	\$0	OTHER FEES AND SERVICES	4010	\$71
\$210,175	\$230,833	\$68,765	\$68,765	\$0	TOTL		\$239,456
\$210,175	\$230,833	\$68,765	\$68,765	\$0	TOTAL FOR ACTIVITY	1200	\$239,456
\$210,175	\$230,833	\$68,765	\$68,765	\$0	TOTAL FOR ORGANIZATION	0210	\$239,456
\$210,175	\$230,833	\$68,765	\$68,765	\$0	TOTAL FOR AGENCY	021	\$239,456
							\$245,715
							\$245,715
							\$245,715
							\$245,715

EXPENSE BUDGET BY OBJECT

FUND	010	GENERAL FUND	AGENCY:	022	JUSTICE OF THE PEACE 4	ACTIVITY:	1200	ADMINISTRATION OF JUSTICE	FUNC.
ORG.	0220	JUSTICE OF THE PEACE #4							
			BUDGET	1999	EXP THRU	TOTAL EST	ACCOUNT NAME	OBJECT	BUDGET
			AS MODIFIED	10/22/99	EXPENDITURE				REQUEST
			\$162,714	\$36,900	\$0	\$0	SALARIES AND LABOR	0200	\$171,830
			\$147,063	\$2,444	\$0	\$0	TEMPORARY OR PART-TIME	0201	\$15,660
			\$1,885	\$338	\$0	\$0	LONGEVITY	0250	\$1,539
			\$12,198	\$2,984	\$0	\$0	SOCIAL SECURITY	0300	\$14,959
			\$14,825	\$4,042	\$0	\$0	RETIREMENT	0400	\$21,509
			\$22,750	\$21,000	\$0	\$0	INSURANCE(GROUP)	0500	\$22,500
			\$4,713	\$3,430	\$0	\$0	WORKERS COMP/UNEMPLOYMENT0600		\$3,645
			\$1,080	\$281	\$0	\$0	TRAVEL REIMB/CONFERENCES 0701		\$2,000
			\$4,641	\$572	\$0	\$0	PROPERTY & EQUIPMENT 1010		\$600
			\$6,025	\$631	\$0	\$0	OFFICE SUPPLIES 1062		\$5,000
			\$4,472	\$648	\$0	\$0	UTILITIES 2000		\$5,500
			\$192	\$112	\$0	\$0	OTHER RENTALS 3020		\$1,160
			\$277	\$179	\$0	\$0	INFORMATION TECHNOLOGY LE3021		\$3,360
			\$277	\$179	\$0	\$0	OTHER FEES AND SERVICES 4010		\$800
					\$0	\$0	REPAIRS TO BUILDING 7012		\$9,500
			\$236,725	\$73,740	\$0	\$0	TOTL		\$280,349
			\$236,725	\$73,740	\$0	\$0	TOTAL FOR ACTIVITY 1200		\$285,571
			\$236,725	\$73,740	\$0	\$0	TOTAL FOR ORGANIZATION 0220		\$285,571
			\$236,725	\$73,740	\$0	\$0	TOTAL FOR AGENCY 022		\$285,571

EXPENSE BUDGET BY OBJECT

FUND. 010 GENERAL FUND
 ORG 0230 CONSTABLE PCT 1

AGENCY: 023 CONSTABLE 1
 ACTIVITY: 1600 PUBLIC SAFETY

1998 EXPENDITURE \$430,610	BUDGET AS MODIFIED \$460,771	1999 EXP THRU 10/22/99 \$100,733	TOTAL EST EXPENDITURE \$0	ACCOUNT NAME	OBJECT	BUDGET REQUEST	RECOM ENDED	ADOPED BUDGET	FUNC.
\$430,610	\$460,771	\$100,733	\$0	SALARIES AND LABOR	0200	\$462,400	\$484,413	\$484,413	
				TEMPORARY OR PART-TIME	0201	\$5,000	\$4,000	\$4,000	
\$3,465	\$4,152	\$850	\$0	LONGEVITY	0250	\$5,017	\$5,018	\$5,018	
\$32,302	\$35,562	\$7,566	\$0	SOCIAL SECURITY	0300	\$36,140	\$37,747	\$37,747	
\$43,154	\$51,135	\$11,028	\$0	RETIREMENT	0400	\$51,416	\$53,837	\$53,837	
\$54,600	\$58,800	\$58,800	\$0	INSURANCE(GROUP)	0500	\$58,800	\$63,000	\$63,000	
\$11,654	\$9,304	\$9,304	\$0	WORKERS COMP/UNEMPLOYMENT	0600	\$14,461	\$9,527	\$9,527	
\$0	\$0	\$0	\$0	TRAVEL ALLOWANCE	0700	\$0	\$0	\$0	
\$2,466	\$3,000	\$1,206	\$0	TRAVEL REIMB/CONFERENCES	0701	\$3,000	\$3,000	\$3,000	
\$92,996	\$4,835	\$2,605	\$0	PROPERTY AND EQUIPMENT	1010	\$3,780	\$3,780	\$3,780	
\$3,475	\$3,500	\$570	\$0	CAPITAL ASSETS	1011	\$22,295	\$22,295	\$22,295	
\$3,475	\$3,500	\$570	\$0	HARDWARE PURCHASES	1012	\$2,159	\$2,159	\$2,159	
\$3,475	\$3,500	\$570	\$0	OFFICE SUPPLIES	1062	\$3,500	\$3,500	\$3,500	
\$4,630	\$4,800	\$839	\$0	UTILITIES	2000	\$4,800	\$4,800	\$4,800	
\$669	\$1,825	\$461	\$0	OTHER RENTALS	3020	\$2,875	\$2,700	\$2,700	
\$669	\$1,825	\$461	\$0	INFORMATION TECHNOLOGY	LE3021	\$492	\$492	\$492	
\$1,169	\$400	\$0	\$0	OTHER FEES AND SERVICES	4010	\$325	\$325	\$325	
\$5,912	\$4,986	\$1,220	\$0	UNIFORMS	4011	\$3,500	\$3,000	\$3,000	
\$0	\$39,928	\$0	\$0	AUTOMOBILES	6025	\$42,000	\$42,000	\$42,000	
\$0	\$2,317	\$0	\$0	RADIOS	6026	\$0	\$0	\$0	
\$0	\$0	\$0	\$0	REPAIRS & MAINT/RADIOS	7020	\$0	\$0	\$0	
\$1,125,331	\$1,154,911	\$297,516	\$0	TOTL	TOTL	\$721,960	\$745,593	\$745,593	

EXPENSE BUDGET BY OBJECT

FUND	010	GENERAL FUND	AGENCY:	023	CONSTABLE 1	EXPENDITURE	AS MODIFIED	BUDGET	1999	EXP THRU	10/22/99	TOTAL EST	EXPENDITURE	OBJECT	BUDGET	RECOM	ENDED	ADOPTED	BUDGET	FUNC
ORG	0230	CONSTABLE PCT 1	ACTIVITY:	1600	PUBLIC SAFETY															
						\$1,125,331	\$1,154,911	\$297,516	\$0	TOTAL FOR ACTIVITY	1600	\$721,960	\$745,593		\$721,960	\$745,593		\$745,593		
						\$1,125,331	\$1,154,911	\$297,516	\$0	TOTAL FOR ORGANIZATION	0230	\$721,960	\$745,593		\$721,960	\$745,593		\$745,593		
						\$1,125,331	\$1,154,911	\$297,516	\$0	TOTAL FOR AGENCY	023	\$721,960	\$745,593		\$721,960	\$745,593		\$745,593		

FUND. 010 GENERAL FUND		AGENCY. 024 CONSTABLE 2		FUNCT.			
ORG 0240 CONSTABLE PCT 2		ACTIVITY: 1600 PUBLIC SAFETY					
1998 BUDGET AS MODIFIED	1999 EXP THRU 10/22/99	TOTAL EST EXPENDITURE	ACCOUNT NAME	OBJECT	BUDGET REQUEST	RECOM ENDED	ADOPTED BUDGET
\$263,985	\$294,063	\$64,645	\$0 SALARIES AND LABOR	0200	\$331,437	\$346,956	\$346,956
\$233,734	\$311,734	\$60,232	\$0 TEMPORARY OR PART-TIME	0201	\$366,390	\$366,390	\$366,390
\$1,428	\$2,131	\$305	\$0 LONGEVITY	0250	\$2,201	\$2,210	\$2,210
\$37,860	\$46,507	\$9,537	\$0 SOCIAL SECURITY	0300	\$53,553	\$54,740	\$54,740
\$31,980	\$66,872	\$10,913	\$0 RETIREMENT	0400	\$77,004	\$78,711	\$78,711
\$31,850	\$37,800	\$37,800	\$0 INSURANCE(GROUP)	0500	\$42,000	\$45,000	\$45,000
\$10,266	\$12,224	\$12,224	\$0 WORKERS COMP/UNEMPLOYMENT	0600	\$21,516	\$13,902	\$13,902
\$0	\$0	\$0	\$0 TRAVEL ALLOWANCE	0700	\$0	\$0	\$0
\$4,438	\$3,500	\$0	\$0 TRAVEL REIMB/CONFERENCES	0701	\$4,505	\$4,000	\$4,000
\$0	\$5,421	\$0	\$0 CONTRACT DEPUTIES SERVICE	0702	\$0	\$0	\$0
\$82,348	\$19,771	\$1,716	\$0 PROPERTY AND EQUIPMENT	1010	\$34,554	\$6,594	\$6,594
\$82,348	\$19,771	\$1,716	\$0 CAPITAL ASSETS	1011	\$23,000	\$10,800	\$10,800
\$82,348	\$19,771	\$1,716	\$0 HARDWARE PURCHASES	1012	\$5,244	\$4,245	\$4,245
\$11,320	\$7,102	\$348	\$0 OFFICE SUPPLIES	1062	\$12,545	\$8,500	\$8,500
\$4,850	\$6,800	\$338	\$0 UTILITIES	2000	\$7,700	\$7,700	\$7,700
\$11,472	\$11,468	\$2,141	\$0 OTHER RENTALS	3020	\$19,850	\$19,000	\$19,000
\$11,472	\$11,468	\$2,141	\$0 INFORMATION TECHNOLOGY LE	3021	\$4,320	\$3,840	\$3,840
\$2,465	\$7,508	\$240	\$0 SOFTWARE PURCHASES	3040	\$3,022	\$3,021	\$3,021
\$2,465	\$7,508	\$240	\$0 OTHER FEES AND SERVICES	4010	\$7,210	\$7,210	\$7,210
\$3,289	\$5,509	\$280	\$0 UNIFORMS	4011	\$6,000	\$3,000	\$3,000
\$0	\$1,500	\$0	\$0 KENNEL SUPPLIES	4016	\$600	\$300	\$300
\$0	\$1,500	\$0	\$0 AUTOMOBILES	6025	\$23,100	\$21,500	\$21,500
\$0	\$1,500	\$0	\$0 ROAD SIGNS	7004	\$1,750	\$350	\$350
\$0	\$1,500	\$0	\$0 REPAIRS -BUILDINGS	7012	\$500	\$0	\$0
\$0	\$1,500	\$0	\$0 REPAIRS & MAINT/RADIOS	7020	\$1,500	\$300	\$300

EXPENSE BUDGET BY OBJECT

FUND: 010 GENERAL FUND
 AGENCY: 024 CONSTABLE 2
 ORG. 0240 CONSTABLE PCT 2
 ACTIVITY: 1600 PUBLIC SAFETY
 FUNC.

1998 EXPENDITURE	BUDGET AS MODIFIED	1999 EXP THRU 10/22/99	TOTAL EST EXPENDITURE	ACCOUNT NAME	OBJECT	BUDGET REQUEST	RECOM ENDED	ADOPTED BUDGET
\$909,918	\$904,428	\$206,532	\$0	TOTAL	TOTAL	\$1,049,501	\$1,008,269	\$1,008,269
\$909,918	\$904,428	\$206,532	\$0	TOTAL FOR ACTIVITY	1600	\$1,049,501	\$1,008,269	\$1,008,269
\$909,918	\$904,428	\$206,532	\$0	TOTAL FOR ORGANIZATION	0240	\$1,049,501	\$1,008,269	\$1,008,269
\$909,918	\$904,428	\$206,532	\$0	TOTAL FOR AGENCY	024	\$1,049,501	\$1,008,269	\$1,008,269

** FORT BEND COUNTY **
 EXPENSE BUDGET BY OBJECT

FUND	010	GENERAL FUND	AGENCY:	025	CONSTABLE 3	ACCOUNT NAME	OBJECT	BUDGET	EXP THRU	TOTAL EST	BUDGET	RECOM	BUDGET	ADOPTED
ORG	0250	CONSTABLE PCT 3	ACTIVITY:	1600	PUBLIC SAFETY		0200	AS MODIFIED	10/22/99	EXPENDITURE	REQUEST	ENDED	BUDGET	BUDGET
								\$320,885	\$68,140	\$320,885	\$353,584	\$370,210	\$370,210	
	\$10,000	\$10,000	\$0	TEMPORARY OR PART-TIME	0201			\$896		\$10,000	\$10,000	\$10,000	\$10,000	
	\$0	\$0	\$0	OVERTIME	0202			\$0		\$0	\$0	\$0	\$0	
	\$4,487	\$4,977	\$968	LONGEVITY	0250			\$968		\$5,085	\$5,085	\$5,085	\$5,085	
	\$25,283	\$28,042	\$5,118	SOCIAL SECURITY	0300			\$5,118		\$28,204	\$29,475	\$29,475	\$29,475	
	\$33,619	\$39,222	\$7,505	RETIREMENT	0400			\$7,505		\$39,454	\$41,282	\$41,282	\$41,282	
	\$40,950	\$58,800	\$58,800	INSURANCE(GROUP)	0500			\$58,800		\$42,000	\$45,000	\$45,000	\$45,000	
	\$9,460	\$7,296	\$7,296	WORKERS COMP/UNEMPLOYMENT	0600			\$7,296		\$11,243	\$7,387	\$7,387	\$7,387	
	\$0	\$0	\$0	TRAVEL ALLOWANCE	0700			\$0		\$0	\$0	\$0	\$0	
	\$1,499	\$3,950	\$247	TRAVEL REIMB/CONFERENCES	0701			\$247		\$5,420	\$4,400	\$4,400	\$4,400	
	\$34,881	\$26,338	\$5,114	PROPERTY AND EQUIPMENT	1010			\$5,114		\$7,840	\$7,695	\$7,695	\$7,695	
	\$7,787	\$5,370	\$783	CAPITAL ASSETS	1011			\$783		\$15,020	\$14,045	\$14,045	\$14,045	
	\$7,787	\$5,370	\$783	HARDWARE PURCHASES	1012			\$783		\$4,871	\$4,702	\$4,702	\$4,702	
	\$7,787	\$5,370	\$783	OFFICE SUPPLIES	1062			\$783		\$5,750	\$5,350	\$5,350	\$5,350	
	\$5,858	\$5,800	\$971	UTILITIES	2000			\$971		\$6,200	\$6,200	\$6,200	\$6,200	
	\$1,234	\$4,200	\$308	OTHER RENTALS	3020			\$308		\$3,400	\$3,200	\$3,200	\$3,200	
	\$1,234	\$4,200	\$308	INFORMATION TECHNOLOGY	LE3021			\$308		\$2,400	\$2,400	\$2,400	\$2,400	
	\$1,234	\$4,200	\$308	SOFTWARE PURCHASES	3040			\$308		\$2,510	\$2,510	\$2,510	\$2,510	
	\$5,694	\$1,375	\$527	OTHER FEES AND SERVICES	4010			\$527		\$1,375	\$1,375	\$1,375	\$1,375	
	\$3,548	\$7,353	\$2,331	UNIFORMS	4011			\$2,331		\$4,100	\$3,800	\$3,800	\$3,800	
	\$0	\$0	\$0	AUTOMOBILES	6025			\$0		\$22,000	\$22,000	\$22,000	\$22,000	
	\$0	\$0	\$0	RADIOS	6026			\$0		\$0	\$0	\$0	\$0	
	\$662	\$600	\$80	REPAIRS & MAINT/RADIOS	7020			\$80		\$600	\$400	\$400	\$400	
	\$532,654	\$543,348	\$161,266	TOTAL				\$161,266		\$571,056	\$586,516	\$586,516	\$586,516	

FUND. 010 GENERAL FUND		AGENCY: 025 CONSTABLE 3		FUNC.				
ORG. 0250 CONSTABLE PCT 3		ACTIVITY. 1600 PUBLIC SAFETY						
1998	BUDGET AS MODIFIED	1999 * * * * * EXP THRU 10/22/99	TOTAL EST EXPENDITURE	ACCOUNT NAME	OBJECT	BUDGET REQUEST	*2000 * * * * * RECOM ENDED	ADOPTED BUDGET
\$532,654	\$543,348	\$161,266	\$0	TOTAL FOR ACTIVITY	1600	\$571,056	\$586,516	\$586,516
\$532,654	\$543,348	\$161,266	\$0	TOTAL FOR ORGANIZATION	0250	\$571,056	\$586,516	\$586,516
\$532,654	\$543,348	\$161,266	\$0	TOTAL FOR AGENCY	025	\$571,056	\$586,516	\$586,516

EXPENSE BUDGET BY OBJECT

FUND. 010 GENERAL FUND
 ORG. 0260 CONSTABLE PCT 4

AGENCY: 026 CONSTABLE 4
 ACTIVITY: 1600 PUBLIC SAFETY

1998 EXPENDITURE \$448,786	BUDGET AS MODIFIED \$485,065	1999 * EXP THRU 10/22/99 \$107,145	TOTAL EST EXPENDITURE \$0	ACCOUNT NAME	OBJECT	BUDGET REQUEST \$491,461	*2000 RECOM ENDED \$514,981	ADOPTED BUDGET \$514,981	FUNC
\$4,201	\$5,102	\$994	\$0	LONGEVITY	0250	\$5,841	\$5,842	\$5,842	
\$33,541	\$37,454	\$7,948	\$0	SOCIAL SECURITY	0300	\$38,044	\$39,843	\$39,843	
\$45,034	\$53,855	\$11,740	\$0	RETIREMENT	0400	\$54,703	\$57,291	\$57,291	
\$67,200	\$63,000	\$63,000	\$0	INSURANCE(GROUP)	0500	\$63,000	\$67,500	\$67,500	
\$13,860	\$9,806	\$9,806	\$0	WORKERS COMP/UNEMPLOYMENT	0600	\$15,230	\$10,054	\$10,054	
\$857	\$2,400	\$80	\$0	TRAVEL REIMB/CONFERENCES	0701	\$1,200	\$1,200	\$1,200	
\$65,342	\$9,172	\$0	\$0	PROPERTY AND EQUIPMENT	1010	\$9,199	\$9,199	\$9,199	
\$65,342	\$9,172	\$0	\$0	CAPITAL ASSETS	1011	\$17,150	\$17,150	\$17,150	
\$6,233	\$4,625	\$1,178	\$0	OFFICE SUPPLIES	1062	\$4,105	\$4,105	\$4,105	
\$5,405	\$5,500	\$895	\$0	UTILITIES	2000	\$6,000	\$6,000	\$6,000	
\$1,916	\$2,400	\$484	\$0	OTHER RENTALS	3020	\$3,000	\$3,000	\$3,000	
\$2,015	\$1,200	\$397	\$0	INFORMATION TECHNOLOGY	LE3021	\$2,400	\$2,400	\$2,400	
\$2,015	\$1,200	\$397	\$0	OTHER FEES AND SERVICES	4010	\$840	\$840	\$840	
\$4,078	\$3,328	\$697	\$0	UNIFORMS	4011	\$3,100	\$3,100	\$3,100	
\$0	\$20,076	\$0	\$0	OFFICERS TRAINING SUPPLIE	4013	\$500	\$500	\$500	
\$0	\$20,076	\$0	\$0	AUTOMOBILES	6025	\$63,000	\$63,000	\$63,000	
\$0	\$4,800	\$0	\$0	RADIOS	6026	\$0	\$0	\$0	
\$0	\$0	\$0	\$0	REPAIRS & MAINT/RADIOS	7020	\$0	\$0	\$0	
\$765,825	\$738,231	\$204,761	\$0	TOTL		\$778,773	\$806,005	\$806,005	
\$765,825	\$738,231	\$204,761	\$0	TOTAL FOR ACTIVITY	1600	\$778,773	\$806,005	\$806,005	
\$765,825	\$738,231	\$204,761	\$0	TOTAL FOR ORGANIZATION	0260	\$778,773	\$806,005	\$806,005	
\$765,825	\$738,231	\$204,761	\$0	TOTAL FOR AGENCY	026	\$778,773	\$806,005	\$806,005	

EXPENSE BUDGET BY OBJECT

FUND	ORG	GENERAL FUND	OPERATING	EXP THRU 10/22/99	BUDGET AS MODIFIED	1999	TOTAL EST EXPENDITURE	ACCOUNT NAME	OBJECT	BUDGET REQUEST	RECOM ENDED	ADOPTED BUDGET
010	0270	GENERAL FUND	OPERATING	\$2,435,030	\$11,826,423	\$2,435,030	\$11,826,423	\$0 SALARIES AND LABOR	0200	\$11,936,716	\$7,522,871	\$7,343,092
				\$2,770	\$12,000	\$4,369	\$4,369	\$0 TEMPORARY OR PART-TIME	0201	\$15,148	\$12,000	\$12,000
				\$0	\$13,000	\$0	\$0	\$0 OVERTIME	0202	\$21,939	\$13,000	\$13,000
				\$24,606	\$123,942	\$106,562	\$106,562	\$0 LONGEVITY	0250	\$141,774	\$92,149	\$92,149
				\$184,803	\$916,077	\$743,136	\$743,136	\$0 SOCIAL SECURITY	0300	\$930,009	\$588,553	\$573,710
				\$268,182	\$1,317,235	\$992,210	\$992,210	\$0 RETIREMENT	0400	\$1,337,267	\$846,283	\$824,943
				\$1,499,400	\$1,499,400	\$1,437,800	\$1,437,800	\$0 INSURANCE(GROUP)	0500	\$1,591,800	\$918,000	\$904,500
				\$244,149	\$244,149	\$300,249	\$300,249	\$0 WORKERS COMP/UNEMPLOYMENT	0600	\$375,324	\$150,477	\$146,690
				\$4,569	\$35,200	\$16,179	\$16,179	\$0 TRAVEL ALLOWANCE	0700	\$41,400	\$39,600	\$39,600
				\$1,349	\$8,400	\$6,550	\$6,550	\$0 TRAVEL REIMB/CONFERENCES	0701	\$10,000	\$8,400	\$8,400
				\$25,582	\$159,768	\$108,710	\$108,710	\$0 PROPERTY AND EQUIPMENT	1010	\$139,193	\$65,028	\$65,028
				\$25,582	\$159,768	\$108,710	\$108,710	\$0 CAPITAL ASSETS	1011	\$530,522	\$354,724	\$354,724
				\$25,582	\$159,768	\$108,710	\$108,710	\$0 HARDWARE PURCHASES	1012	\$20,154	\$6,783	\$6,783
				\$4,377	\$29,045	\$21,103	\$21,103	\$0 REPAIRS TO EQUIPMENT	1020	\$41,800	\$11,500	\$11,500
				\$9,534	\$90,346	\$82,220	\$82,220	\$0 OFFICE SUPPLIES	1062	\$111,097	\$60,450	\$60,450
				\$97,102	\$600,000	\$572,929	\$572,929	\$0 UTILITIES	2000	\$676,000	\$139,800	\$139,800
				\$93,737	\$647,120	\$573,996	\$573,996	\$0 GROCERIES/KITCHEN SUPPLIE	2030	\$725,000	\$0	\$0
				\$18,462	\$62,848	\$53,615	\$53,615	\$0 CLOTHING/BEDDING/LAUNDRY	2040	\$70,000	\$0	\$0
				\$12,788	\$92,710	\$62,150	\$62,150	\$0 MEDICAL SERVICES/MEDICINE	2050	\$120,000	\$0	\$0
				\$19,015	\$65,900	\$42,174	\$42,174	\$0 JANITORIAL AND PEST CONTR	2060	\$90,000	\$0	\$0
				\$4,165	\$55,000	\$31,379	\$31,379	\$0 PHOTO/LAB SUPPLIES	3010	\$79,318	\$49,600	\$49,600
				\$7,150	\$25,900	\$8,802	\$8,802	\$0 OTHER RENTALS	3020	\$65,680	\$38,000	\$38,000
				\$56,669	\$300,346	\$197,296	\$197,296	\$0 INFORMATION TECHNOLOGY	LE3021	\$12,480	\$10,080	\$10,080
				\$56,669	\$300,346	\$197,296	\$197,296	\$0 SOFTWARE PURCHASES	3040	\$14,297	\$12,743	\$12,743
				\$56,669	\$300,346	\$197,296	\$197,296	\$0 OTHER FEES AND SERVICES	4010	\$406,885	\$212,700	\$212,700

EXPENSE BUDGET BY OBJECT

FUND: 010 GENERAL FUND		AGENCY: 027 SHERIFF'S DEPARTMENT		FUNCT:	
ORG: 0270 SHERIFF ENFORCEMENT		ACTIVITY: 1600 PUBLIC SAFETY			
1998	BUDGET AS MODIFIED	1999 * * * * *	TOTAL EST	BUDGET REQUEST	ADOPTED BUDGET
EXPENDITURE	\$112,886	EXP THRU 10/22/99	EXPENDITURE	\$147,477	\$67,475
\$74,778	\$112,886	\$22,618	\$0	\$147,477	\$67,475
\$17,385	\$25,000	\$0	\$0	\$23,200	\$17,675
\$23,415	\$45,000	\$6,497	\$0	\$71,308	\$38,625
\$290,116	\$500,866	\$17,499	\$0	\$1,800	\$1,800
\$290,116	\$500,866	\$17,499	\$0	\$860,000	\$399,000
\$34,959	\$99,494	\$6,337	\$0	\$0	\$0
\$30,711	\$54,000	\$5,914	\$0	\$64,500	\$10,400
\$7,505	\$11,397	\$2,131	\$0	\$15,000	\$15,000
\$16,594,661	\$20,394,546	\$5,256,436	\$0	\$20,687,088	\$11,469,467
\$16,594,661	\$20,394,546	\$5,256,436	\$0	\$20,687,088	\$11,469,467
\$16,594,661	\$20,394,546	\$5,256,436	\$0	\$20,687,088	\$11,469,467

** ** ** ** **
EXPENSE BUDGET BY OBJECT

FUND: 010 GENERAL FUND
ORG. 0271 SHERIFF DETENTION OPERATING
AGENCY: 027 SHERIFF'S DEPARTMENT
ACTIVITY: 1600 PUBLIC SAFETY

BUDGET AS MODIFIED	EXP THRU	TOTAL EST	ACCOUNT NAME	OBJECT	BUDGET REQUEST	RECOM ENDED	ADOPTED BUDGET
** ** ** ** *	** ** ** ** *	** ** ** ** *			** ** ** ** *	** ** ** ** *	** ** ** ** *
\$0	10/22/99		SALARIES & LABOR	0200	\$5,283,150	\$5,283,150	\$5,378,194
\$0			LONGEVITY	0250	\$47,078	\$47,078	\$47,078
\$0			SOCIAL SECURITY	0300	\$407,763	\$407,763	\$415,033
\$0			RETIREMENT	0400	\$586,325	\$586,325	\$596,780
\$0			INSURANCE (GROUP)	0500	\$765,000	\$765,000	\$796,500
\$0			WORKERS COMP/UNEMPLOYMENT	0600	\$105,006	\$105,006	\$106,878
\$0			PROPERTY & EQUIPMENT	1010	\$11,166	\$11,166	\$11,166
\$0			CAPITAL ASSETS	1011	\$52,047	\$52,047	\$52,047
\$0			I.T HARDWARE PURCHASES	1012	\$7,836	\$7,836	\$7,836
\$0			REPAIRS TO EQUIPMENT	1020	\$19,270	\$19,270	\$19,270
\$0			OFFICE SUPPLIES	1062	\$15,775	\$15,775	\$15,775
\$0			UTILITIES	2000	\$560,000	\$560,000	\$560,000
\$0			GROCERIES	2030	\$650,000	\$650,000	\$650,000
\$0			CLOTHING/BEDDING/LAUNDRY	2040	\$65,000	\$65,000	\$65,000
\$0			MEDICAL SERVICES/MEDICINE	2050	\$95,000	\$95,000	\$95,000
\$0			JANITORIAL AND PEST CONTR	2060	\$80,000	\$80,000	\$80,000
\$0			PHOTO/LAB SUPPLIES	3010	\$2,700	\$2,700	\$2,700
\$0			I.T LEASES	3021	\$2,400	\$2,400	\$2,400
\$0			OTHER FEES AND SERVICES	4010	\$167,300	\$167,300	\$167,300
\$0			UNIFORMS	4011	\$51,325	\$51,325	\$51,325
\$0			OFFICERS TRAINING SUPPLIE	4013	\$5,525	\$5,525	\$5,525
\$0			EDUCATION EXPENSE	4014	\$13,875	\$13,875	\$13,875
\$0			REPAIRS TO BUILDING	7012	\$41,600	\$41,600	\$41,600
\$0			TOTL		\$9,035,141	\$9,035,141	\$9,181,282

FUND. 010 GENERAL FUND		AGENCY. 027 SHERIFF'S DEPARTMENT		FUNC.		
ORG. 0271 SHERIFF DETENTION OPERATING		ACTIVITY. 1600 PUBLIC SAFETY				
1998	BUDGET AS MODIFIED	1999 * * * * * EXP THRU 10/22/99	TOTAL EST EXPENDITURE	BUDGET REQUEST	RECOM ENDED	ADOPTED BUDGET
\$0	\$0	\$0	\$0	\$0	\$9,035,141	\$9,181,282
\$0	\$0	\$0	\$0	\$0	\$9,035,141	\$9,181,282
\$16,594,661	\$20,394,546	\$5,256,436	\$0	\$20,687,088	\$20,737,857	\$20,650,749
					TOTAL FOR ACTIVITY 1600	
					TOTAL FOR ORGANIZATION 0271	
					TOTAL FOR AGENCY 027	

FUND, 010 GENERAL FUND	AGENCY 028 VEHICLE MAINTENANCE	ACCOUNT NAME	OBJECT	BUDGET REQUEST	RECOM ENDED	ADOPTED BUDGET
ORG. 0280 VEHICLE MAINTENANCE	ACTIVITY. 1000 GENERAL ADMINISTRATION			\$191,636	\$201,217	\$201,218
1998 EXPENDITURE AS MODIFIED	10/22/99 EXPENDITURE	TOTAL EST				
\$179,092	\$191,889	\$41,117	\$0 SALARIES AND LABOR	\$191,636	\$201,217	\$201,218
\$8,102	\$0	\$0	\$0 TEMPORARY OR PART-TIME	\$16,640	\$10,000	\$10,000
\$3,325	\$3,639	\$737	\$0 LONGEVITY	\$3,997	\$3,997	\$3,997
\$13,479	\$14,968	\$2,974	\$0 SOCIAL SECURITY	\$16,239	\$16,464	\$16,464
\$18,590	\$21,522	\$4,547	\$0 RETIREMENT	\$21,520	\$22,574	\$22,574
\$27,300	\$25,200	\$25,200	\$0 INSURANCE(GROUP)	\$25,200	\$27,000	\$27,000
\$5,978	\$3,986	\$3,986	\$0 WORKERS COMP/UNEMPLOYMENT	\$6,560	\$4,240	\$4,240
\$0	\$0	\$0	\$0 TRAVEL ALLOWANCE	\$0	\$0	\$0
\$0	\$1,625	\$0	\$0 TRAVEL REIMB/CONFERENCES	\$2,600	\$1,900	\$1,900
\$12,266	\$23,795	\$1,863	\$0 PROPERTY AND EQUIPMENT	\$2,645	\$2,645	\$2,645
\$4,579	\$0	\$0	\$0 REPAIRS TO EQUIPMENT	\$0	\$0	\$0
\$2,612	\$2,659	\$472	\$0 OFFICE SUPPLIES	\$2,550	\$2,550	\$2,550
\$16,362	\$21,950	\$2,594	\$0 UTILITIES	\$21,950	\$21,950	\$21,950
\$6,434	\$5,230	\$876	\$0 OTHER RENTALS	\$5,500	\$5,500	\$5,500
\$11,074	\$29,900	\$1,021	\$0 INFORMATION TECHNOLOGY	\$2,905	\$480	\$480
\$11,074	\$29,900	\$1,021	\$0 FEES AND SERVICES	\$29,900	\$22,425	\$22,425
\$11,074	\$29,900	\$1,021	\$0 UNIFORMS	\$10,000	\$5,000	\$5,000
\$269,284	\$396,555	\$43,782	\$0 AUTOMOBILES	\$35,500	\$20,000	\$20,000
\$269,284	\$396,555	\$43,782	\$0 GAS AND OIL	\$385,000	\$350,000	\$350,000
\$61,823	\$75,061	\$12,052	\$0 TIRES AND TUBES	\$70,000	\$62,000	\$62,000
\$0	\$205,000	\$37,604	\$0 REPAIRS & PARTS/SHOP SUPP	\$250,000	\$215,000	\$215,000
\$0	\$1,750	\$0	\$0 REPAIRS - BUILDINGS	\$0	\$0	\$0
\$216,077	\$4,392	\$3,856	\$0 REPAIRS & MAINT/MRT EQUIP	\$0	\$0	\$0
\$10,628	\$0	\$0	\$0 SHOP SUPPLIES	\$0	\$0	\$0

FUND. 010 GENERAL FUND		AGENCY: 028 VEHICLE MAINTENANCE		FUNCT:	
ORG 0280 VEHICLE MAINTENANCE		ACTIVITY: 1000 GENERAL ADMINISTRATION			
BUDGET AS MODIFIED	1999 * * * * * EXP THRU 10/22/99	TOTAL EST EXPENDITURE	ACCOUNT NAME	OBJECT	TOTL
\$1,158,437	\$1,485,476	\$228,505			\$1,100,362
\$1,158,437	\$1,485,476	\$228,505	TOTAL FOR ACTIVITY	1000	\$1,100,362
\$1,158,437	\$1,485,476	\$228,505	TOTAL FOR ORGANIZATION	0280	\$1,100,362
\$1,158,437	\$1,485,476	\$228,505	TOTAL FOR AGENCY	028	\$1,100,362
					\$994,943
					\$994,943
					\$994,943
					\$994,943

** FORT BEND COUNTY **
EXPENSE BUDGET BY OBJECT

FUND: 010 GENERAL FUND
ORG: 0290 SOCIAL SERVICES

AGENCY: 029 SOCIAL SERVICES
ACTIVITY: 1400 HEALTH AND WELFARE

1998	BUDGET AS MODIFIED	1999 EXP THRU 10/22/99	TOTAL EST EXPENDITURE	ACCOUNT NAME	OBJECT	BUDGET REQUEST	RECOM ENDED	ADOPTED BUDGET	FUNC:
\$181,388	\$197,750	\$42,824	\$0	SALARIES AND LABOR	0200	\$287,372	\$256,953	\$256,953	
\$0	\$2,080	\$439	\$0	TEMPORARY OR PART-TIME	0201	\$0	\$0	\$0	
\$2,448	\$2,809	\$573	\$0	LONGEVITY	0250	\$3,225	\$3,225	\$3,225	
\$13,392	\$15,343	\$3,190	\$0	SOCIAL SECURITY	0300	\$22,232	\$19,904	\$19,904	
\$18,278	\$22,062	\$4,713	\$0	RETIREMENT	0400	\$31,966	\$28,620	\$28,620	
\$31,850	\$29,400	\$29,400	\$0	INSURANCE(GROUP)	0500	\$46,200	\$40,500	\$40,500	
\$5,788	\$4,057	\$4,057	\$0	WORKERS COMP/UNEMPLOYMENT	0600	\$6,862	\$5,125	\$5,125	
\$0	\$0	\$0	\$0	TRAVEL ALLOWANCE	0700	\$0	\$0	\$0	
\$7,120	\$8,700	\$302	\$0	TRAVEL REIMB/CONFERENCES	0701	\$10,550	\$8,700	\$8,700	
\$383	\$1,794	\$294	\$0	PROPERTY AND EQUIPMENT	1010	\$7,052	\$3,640	\$3,640	
\$4,099	\$3,666	\$502	\$0	CAPITAL ASSETS	1011	\$5,995	\$5,995	\$5,995	
\$4,099	\$3,666	\$502	\$0	OFFICE SUPPLIES	1062	\$3,600	\$3,600	\$3,600	
\$9,137	\$9,500	\$1,221	\$0	UTILITIES	2000	\$9,500	\$9,500	\$9,500	
\$14,944	\$10,000	\$958	\$0	GROCERIES	2030	\$13,000	\$13,000	\$13,000	
\$39,619	\$33,000	\$2,623	\$0	MEDICAL SERVICES/MEDICINE	2050	\$33,000	\$33,000	\$33,000	
\$2,009	\$0	\$0	\$0	MEDICAL-PRESCRIPTIONS	DN2051	\$0	\$0	\$0	
\$511	\$2,916	\$172	\$0	OTHER RENTALS	3020	\$2,816	\$2,816	\$2,816	
\$4,099	\$3,666	\$502	\$0	INFORMATION TECHNOLOGY	LE3021	\$3,960	\$3,150	\$3,150	
\$4,099	\$3,666	\$502	\$0	SOFTWARE PURCHASES	3040	\$30,000	\$30,000	\$30,000	
\$38,317	\$40,750	\$19,361	\$0	OTHER FEES AND SERVICES	4010	\$40,800	\$40,800	\$40,800	
\$381,580	\$394,825	\$112,135	\$0	TOTAL	TOTL	\$558,130	\$508,528	\$508,528	
\$381,580	\$394,825	\$112,135	\$0	TOTAL FOR ACTIVITY	1400	\$558,130	\$508,528	\$508,528	
\$381,580	\$394,825	\$112,135	\$0	TOTAL FOR ORGANIZATION	0290	\$558,130	\$508,528	\$508,528	
\$381,580	\$394,825	\$112,135	\$0	TOTAL FOR AGENCY	029	\$558,130	\$508,528	\$508,528	

EXPENSE BUDGET BY OBJECT

FUND. 010 GENERAL FUND		AGENCY: 030 LIBRARY		ACTIVITY: 1900 LIBRARIES AND EDUCATION		FUNCC.	
1998	BUDGET	1999	TOTAL EST	ACCOUNT NAME	OBJECT	BUDGET	ADOPTED
EXPENDITURE	AS MODIFIED	EXP THRU	EXPENDITURE			REQUEST	BUDGET
\$2,058,256	\$2,499,211	10/22/99	\$489,228	\$0 SALARIES AND LABOR	0200	\$2,588,134	\$2,681,679
\$439,638	\$567,563	\$102,256		\$0 TEMPORARY OR PART-TIME	0201	\$606,261	\$597,000
\$28,914	\$33,176	\$6,448		\$0 OVERTIME	0202	\$116,343	\$0
\$28,914	\$33,176	\$6,448		\$0 LONGEVITY	0250	\$37,879	\$36,160
\$187,686	\$237,146	\$44,898		\$0 SOCIAL SECURITY	0300	\$247,269	\$253,585
\$224,302	\$328,271	\$57,473		\$0 RETIREMENT	0400	\$339,282	\$346,200
\$376,425	\$399,000	\$399,000		\$0 INSURANCE(GROUP)	0500	\$403,200	\$427,500
\$80,974	\$63,258	\$63,258		\$0 WORKERS COMP/UNEMPLOYMENT	0600	\$100,201	\$65,302
\$0	\$0	\$0		\$0 TRAVEL ALLOWANCE	0700	\$0	\$0
\$12,040	\$12,000	\$3,692		\$0 TRAVEL REIMB/CONFERENCES	0701	\$15,900	\$12,000
\$152,124	\$430,110	\$19,480		\$0 PROPERTY AND EQUIPMENT	1010	\$43,337	\$35,000
\$6,241	\$5,950	\$199		\$0 CAPITAL ASSETS	1011	\$56,402	\$39,000
\$6,241	\$5,950	\$199		\$0 HARDWARE PURCHASES	1012	\$227,113	\$145,000
\$6,241	\$5,950	\$199		\$0 REPAIRS TO EQUIPMENT	1020	\$6,545	\$6,100
\$44,423	\$44,000	\$10,290		\$0 OFFICE SUPPLIES	1062	\$43,800	\$44,000
\$347,676	\$374,603	\$60,673		\$0 UTILITIES	2000	\$456,553	\$434,203
\$22,926	\$23,720	\$2,811		\$0 JANITORIAL AND PEST CONTR	2060	\$27,459	\$25,500
\$75,083	\$86,689	\$31,223		\$0 MATERIALS AND SUPPLIES	3000	\$129,372	\$86,000
\$16,795	\$23,974	\$3,550		\$0 OTHER RENTALS	3020	\$24,848	\$24,848
\$926,631	\$1,029,146	\$81,917		\$0 INFORMATION TECHNOLOGY	LE3021	\$33,984	\$54,500
\$926,631	\$1,029,146	\$81,917		\$0 SOFTWARE PURCHASES	3040	\$26,296	\$26,000
\$926,631	\$1,029,146	\$81,917		\$0 BOOKS AND MAGAZINES	3050	\$1,321,777	\$1,200,600
\$203,280	\$238,295	\$63,775		\$0 OTHER FEES AND SERVICES	4010	\$304,415	\$234,500
\$1,268	\$1,623	\$192		\$0 UNIFORMS	4011	\$1,704	\$1,704
\$0	\$0	\$0		\$0 AUTOMOBILES	6025	\$21,500	\$0

FUND. 010 GENERAL FUND
 ORG. 0310 HEALTH DEPT-COUNTY

AGENCY. 031 HEALTH DEPARTMENT
 ACTIVITY. 1400 HEALTH AND WELFARE

FUNC.

1998 EXPENDITURE	BUDGET AS MODIFIED	1999 EXP THRU 10/22/99	TOTAL EST EXPENDITURE	ACCOUNT NAME	OBJECT	BUDGET REQUEST	*2000 RECOM ENDED	ADOPTED BUDGET
\$486,463	\$625,144	\$115,989	\$0	\$0 SALARIES AND LABOR	0200	\$709,908	\$620,625	\$620,878
\$0	\$0	\$0	\$0	\$0 TEMPORARY OR PART-TIME	0201	\$0	\$0	\$0
\$4,732	\$5,876	\$1,082	\$0	\$0 LONGEVITY	0250	\$6,492	\$6,521	\$6,521
\$35,918	\$48,273	\$8,513	\$0	\$0 SOCIAL SECURITY	0300	\$54,805	\$47,977	\$47,996
\$48,841	\$69,413	\$12,710	\$0	\$0 RETIREMENT	0400	\$78,804	\$68,986	\$69,014
\$77,350	\$84,000	\$84,000	\$0	\$0 INSURANCE(GROUP)	0500	\$88,200	\$85,500	\$85,500
\$15,879	\$12,733	\$12,733	\$0	\$0 WORKERS COMP/UNEMPLOYMENT	0600	\$22,209	\$12,355	\$12,360
\$8,797	\$15,000	\$1,956	\$0	\$0 TRAVEL REIMB/CONFERENCES	0701	\$16,720	\$12,500	\$12,500
\$20,789	\$23,914	\$436	\$0	\$0 PROPERTY AND EQUIPMENT	1010	\$2,000	\$2,000	\$2,000
\$11,619	\$11,211	\$1,423	\$0	\$0 CAPITAL ASSETS	1011	\$50,000	\$50,000	\$50,000
\$11,619	\$11,211	\$1,423	\$0	\$0 HARDWARE PURCHASES	1012	\$2,868	\$2,868	\$2,868
\$11,619	\$11,211	\$1,423	\$0	\$0 OFFICE SUPPLIES/POSTAGE	1062	\$8,116	\$8,116	\$8,116
\$16,434	\$19,800	\$2,814	\$0	\$0 UTILITIES	2000	\$18,700	\$18,700	\$18,700
\$7,689	\$8,583	\$1,383	\$0	\$0 MEDICAL SERVICES/MEDICINE	2050	\$10,000	\$9,000	\$9,000
\$0	\$3,200	\$181	\$0	\$0 OTHER RENTALS	3020	\$3,956	\$3,956	\$3,956
\$33,184	\$34,300	\$8,245	\$0	\$0 INFORMATION TECHNOLOGY	LE3021	\$2,880	\$2,740	\$2,740
\$33,184	\$34,300	\$8,245	\$0	\$0 FEES AND SERVICES	4010	\$34,200	\$34,200	\$34,200
\$0	\$500	\$500	\$0	\$0 UNIFORMS	4011	\$500	\$500	\$500
\$508	\$4,000	\$0	\$0	\$0 EDUCATION EXPENSE	4014	\$4,200	\$4,200	\$4,200
\$0	\$55,500	\$300	\$0	\$0 AUTOMOBILES	6025	\$38,600	\$0	\$0
\$0	\$55,500	\$300	\$0	\$0 GAS AND OIL	7005	\$1,000	\$0	\$0
\$0	\$55,500	\$300	\$0	\$0 TIRES AND TUBES	7006	\$2,600	\$0	\$0
\$0	\$55,500	\$300	\$0	\$0 REPAIRS & PARTS/SHOP SUP	7007	\$200	\$0	\$0
\$824,625	\$1,244,669	\$264,256	\$0	TOTL	TOTL	\$1,156,958	\$990,744	\$991,049

FUND, 010 GENERAL FUND		AGENCY, 031 HEALTH DEPARTMENT		FUNC	
ORG, 0310 HEALTH DEPT-COUNTY		ACTIVITY: 1400 HEALTH AND WELFARE			
1998	1999	TOTAL EST	BUDGET REQUEST	RECOM ENDED	ADOPTED BUDGET
EXPENDITURE AS MODIFIED	EXP THRU 10/22/99	EXPENDITURE			
\$824,625	\$1,244,669	\$0	\$1,156,958	\$990,744	\$991,049
\$824,625	\$1,244,669	\$0	\$1,156,958	\$990,744	\$991,049
\$824,625	\$1,244,669	\$0	\$1,156,958	\$990,744	\$991,049
			TOTAL FOR ACTIVITY 1400		
			TOTAL FOR ORGANIZATION 0310		
			TOTAL FOR AGENCY 031		

** FORT BEND COUNTY **
 EXPENSE BUDGET BY OBJECT

FUND, 010 GENERAL FUND	AGENCY: 032 EXTENSION SERVICE	FUNC:
ORG. 0320 EXTENSION SERVICE	ACTIVITY: 1500 COOPERATIVE SERVICE	
1998 BUDGET AS MODIFIED	TOTAL EST EXPENDITURE	BUDGET REQUEST
EXPENDITURE AS MODIFIED	EXPENDITURE	RECORDED ENDED
EXPENDITURE AS MODIFIED	EXPENDITURE	ADOPTED BUDGET
\$227,656	\$251,214	\$280,833
\$8,433	\$4,896	\$32,000
\$1,343	\$289	\$1,491
\$10,927	\$2,936	\$24,637
\$12,396	\$3,306	\$35,425
\$50,050	\$46,200	\$49,500
\$7,369	\$5,409	\$6,344
\$0	\$0	\$0
\$31,046	\$4,934	\$35,000
\$30,638	\$2,925	\$5,150
\$30,638	\$2,925	\$14,647
\$30,638	\$2,925	\$14,589
\$26,741	\$3,938	\$5,000
\$18,593	\$0	\$21,775
\$31,436	\$4,185	\$10,000
\$8,276	\$1,324	\$29,000
\$7,055	\$2,685	\$15,000
\$1,071	\$683	\$13,500
\$1,071	\$683	\$4,800
\$4,693	\$1,210	\$5,778
\$0	\$0	\$1,270
\$3,969	\$751	\$4,300
		\$0
		\$5,000
		\$5,000

EXPENSE BUDGET BY OBJECT

FUND 010 GENERAL FUND
 AGENCY: 032 EXTENSION SERVICE
 ORG 0320 EXTENSION SERVICE
 ACTIVITY: 1500 COOPERATIVE SERVICE
 FUNC:

1998	BUDGET AS MODIFIED	1999 * * * * * EXP THRU 10/22/99	TOTAL EST EXPENDITURE	ACCOUNT NAME	OBJECT	BUDGET REQUEST	*2000 * * * * * RECOM ENDED	ADOPTED BUDGET
\$544,039	\$591,860	\$149,654	\$0	TOTAL	TOTL	\$620,532	\$615,039	\$615,040
\$544,039	\$591,860	\$149,654	\$0	TOTAL FOR ACTIVITY	1500	\$620,532	\$615,039	\$615,040
\$544,039	\$591,860	\$149,654	\$0	TOTAL FOR ORGANIZATION	0320	\$620,532	\$615,039	\$615,040
\$544,039	\$591,860	\$149,654	\$0	TOTAL FOR AGENCY	032	\$620,532	\$615,039	\$615,040

FUND. 010 GENERAL FUND		AGENCY: 033 FAIRGROUNDS		FUNC.			
ORG. 0330 FAIRGROUNDS		ACTIVITY: 1700 PARKS AND RECREATION					
BUDGET AS MODIFIED	1999 EXP THRU 10/22/99	TOTAL EST EXPENDITURE	ACCOUNT NAME	OBJECT	BUDGET REQUEST	*2000 RECOM ENDED	ADOPTED BUDGET
\$56,775	\$12,381	\$0	\$0 SALARIES AND LABOR	0200	\$69,682	\$73,167	\$73,167
\$11,653	\$1,067	\$0	\$0 TEMPORARY OR PART-TIME	0201	\$20,000	\$20,000	\$20,000
\$257	\$78	\$0	\$0 LONGEVITY	0250	\$346	\$376	\$376
\$5,254	\$1,035	\$0	\$0 SOCIAL SECURITY	0300	\$6,861	\$7,156	\$7,156
\$5,670	\$1,352	\$0	\$0 RETIREMENT	0400	\$7,665	\$8,090	\$8,090
\$13,650	\$12,600	\$0	\$0 INSURANCE(GROUP)	0500	\$12,600	\$13,500	\$13,500
\$2,331	\$1,548	\$0	\$0 WORKERS COMP/UNEMPLOYMENT0600	0600	\$2,780	\$1,843	\$1,843
\$9,880	\$2,356	\$0	\$0 PROPERTY AND EQUIPMENT	1010	\$8,400	\$8,400	\$8,400
\$1,299	\$374	\$0	\$0 REPAIRS TO EQUIPMENT	1020	\$3,000	\$3,000	\$3,000
\$25,514	\$2,607	\$0	\$0 PERMANENT IMPROVEMENT	1070	\$40,000	\$40,000	\$40,000
\$71,549	\$9,075	\$0	\$0 UTILITIES	2000	\$82,000	\$82,000	\$82,000
\$5,932	\$0	\$0	\$0 JANITORIAL AND PEST CONTR2060	2060	\$5,500	\$5,500	\$5,500
\$15,720	\$0	\$0	\$0 MATERIALS AND SUPPLIES	3000	\$20,000	\$15,000	\$15,000
\$0	\$68	\$0	\$0 OTHER RENTALS	3020	\$1,325	\$1,325	\$1,325
\$3,149	\$0	\$0	\$0 OTHER FEES AND SERVICES	4010	\$5,000	\$5,000	\$5,000
\$1,469	\$226	\$0	\$0 UNIFORMS	4011	\$2,000	\$1,500	\$1,500
\$39,599	\$5,546	\$0	\$0 REPAIRS-BUILDINGS	7012	\$50,000	\$42,500	\$42,500
\$269,701	\$50,313	\$0	\$0	TOTL	\$337,159	\$328,357	\$328,357
\$269,701	\$50,313	\$0	\$0	TOTAL FOR ACTIVITY	\$337,159	\$328,357	\$328,357
\$269,701	\$50,313	\$0	\$0	TOTAL FOR ORGANIZATION	\$337,159	\$328,357	\$328,357
\$269,701	\$50,313	\$0	\$0	TOTAL FOR AGENCY	\$337,159	\$328,357	\$328,357

FUND	ORG	GENERAL FUND	AGENCY:	035 VETERANS SERVICE	ACCOUNT NAME	OBJECT	BUDGET REQUEST	RECOM ENDED	ADOPTED BUDGET
1998	010	0350 VETERANS SERVICE	ACTIVITY:	1500 COOPERATIVE SERVICE			\$38,914	\$40,560	\$40,859
					\$0 SALARIES AND LABOR	0200	\$882	\$882	\$882
					\$0 LONGEVITY	0250	\$3,121	\$3,193	\$3,193
					\$0 SOCIAL SECURITY	0300	\$4,488	\$4,592	\$4,592
					\$0 RETIREMENT	0400	\$4,200	\$4,500	\$4,500
					\$0 INSURANCE(GROUP)	0500	\$1,265	\$822	\$822
					\$0 WORKERS COMP/UNEMPLOYMENT	0600	\$0	\$0	\$0
					\$0 TRAVEL ALLOWANCE	0700	\$2,662	\$2,662	\$2,662
					\$0 TRAVEL REIMS/CONFERENCES	0701	\$0	\$0	\$0
					\$0 PROPERTY & EQUIP	1010	\$740	\$740	\$740
					\$0 OFFICE SUPPLIES	1062	\$180	\$180	\$180
					\$0 OTHER RENTALS	3020	\$210	\$710	\$710
					\$0 OTHER FEES & SERVICES	4010	\$500	\$0	\$0
					\$0 CONTINGENCY	4040	\$0	\$0	\$0
					\$0 AUTOMOBILES	6025	\$0	\$0	\$0
					TOTAL		\$57,162	\$58,841	\$59,140
					TOTAL FOR ACTIVITY	1500	\$57,162	\$58,841	\$59,140
					TOTAL FOR ORGANIZATION	0350	\$57,162	\$58,841	\$59,140
					TOTAL FOR AGENCY	035	\$57,162	\$58,841	\$59,140

FUND, 010 GENERAL FUND		AGENCY, 036 MANAGEMENT INFORMATION SYSTEMS		FUNC.		
ORG 0360 DATA PROCESSING		ACTIVITY: 1000 GENERAL ADMINISTRATION				
1998	BUDGET AS MODIFIED	TOTAL EST EXPENDITURE	ACCOUNT NAME	OBJECT	BUDGET REQUEST ENDED	ADOPTED BUDGET
\$1,054,317	\$1,174,160	\$225,332	\$0 SALARIES AND LABOR	0200	\$1,356,293	\$1,356,296
\$24,999	\$22,000	\$4,129	\$0 TEMPORARY OR PART-TIME	0201	\$22,000	\$26,357
\$9,811	\$11,551	\$2,051	\$0 LONGEVITY	0250	\$12,382	\$12,362
\$80,881	\$92,390	\$17,248	\$0 SOCIAL SECURITY	0300	\$102,440	\$106,721
\$105,866	\$132,849	\$24,687	\$0 RETIREMENT	0400	\$147,299	\$153,455
\$141,050	\$134,400	\$134,400	\$0 INSURANCE(GROUP)	0500	\$151,200	\$157,500
\$34,780	\$24,650	\$24,650	\$0 WORKERS COMP/UNEMPLOYMENT	0600	\$41,420	\$27,482
\$0	\$0	\$0	\$0 TRAVEL ALLOWANCE	0700	\$0	\$0
\$8,352	\$8,200	\$848	\$0 TRAVEL REIMB/CONFERENCES	0701	\$8,500	\$7,500
\$712,280	\$409,411	\$23,694	\$0 PROPERTY AND EQUIPMENT	1010	\$4,040	\$3,340
\$712,280	\$409,411	\$23,694	\$0 CAPITAL ASSETS	1011	\$34,000	\$34,000
\$712,280	\$409,411	\$23,694	\$0 HARDWARE PURCHASES	1012	\$394,500	\$340,500
\$77,432	\$80,198	\$9,145	\$0 OFFICE SUPPLIES	1062	\$80,000	\$70,000
\$183,487	\$259,986	\$10,680	\$0 OTHER RENTALS	3020	\$312,400	\$379,916
\$183,487	\$259,986	\$10,680	\$0 INFORMATION TECHNOLOGY	LE3021	\$18,360	\$10,220
\$219,074	\$210,034	\$31,268	\$0 SOFTWARE PURCHASES	3040	\$1,206,496	\$230,800
\$591,044	\$814,834	\$127,706	\$0 OTHER FEES AND SERVICES	4010	\$669,330	\$914,365
\$0	\$19,344	\$0	\$0 AUTOMOBILES	6025	\$19,000	\$0
\$4,851,420	\$4,472,815	\$693,906	\$0 TOTAL	TOTAL	\$4,525,111	\$3,830,814
\$4,851,420	\$4,472,815	\$693,906	\$0 TOTAL FOR ACTIVITY	1000	\$4,525,111	\$3,830,814
\$4,851,420	\$4,472,815	\$693,906	\$0 TOTAL FOR ORGANIZATION	0360	\$4,525,111	\$3,830,814
\$4,851,420	\$4,472,815	\$693,906	\$0 TOTAL FOR AGENCY	036	\$4,525,111	\$3,830,814

1998	BUDGET AS MODIFIED	EXPENDITURE	10/22/99	1999	EXP THRU	TOTAL EST	ACCOUNT NAME	OBJECT	BUDGET REQUEST	RECOM ENDED	ADOPTED BUDGET
\$180,468	\$188,887	\$40,260	\$40,260	\$0	\$0	\$0	SALARIES AND LABOR	0200	\$205,378	\$215,718	\$215,938
\$2,273	\$2,655	\$531	\$531	\$0	\$0	\$0	LONGEVITY	0250	\$3,076	\$3,076	\$3,076
\$13,479	\$14,653	\$3,029	\$3,029	\$0	\$0	\$0	SOCIAL SECURITY	0300	\$15,947	\$16,738	\$16,755
\$18,168	\$21,070	\$4,430	\$4,430	\$0	\$0	\$0	RETIREMENT	0400	\$22,930	\$24,067	\$24,092
\$31,850	\$29,400	\$29,400	\$29,400	\$0	\$0	\$0	INSURANCE(GROUP)	0500	\$33,600	\$36,000	\$36,000
\$5,574	\$3,884	\$3,884	\$3,884	\$0	\$0	\$0	WORKERS COMP/UNEMPLOYMENT	0600	\$6,462	\$4,310	\$4,315
\$0	\$1,800	\$0	\$0	\$0	\$0	\$0	TRAVEL REIMB/CONFERENCES	0701	\$2,000	\$2,000	\$2,000
\$20,466	\$12,219	\$391	\$391	\$0	\$0	\$0	PROPERTY AND EQUIPMENT	1010	\$1,400	\$1,400	\$1,400
\$20,466	\$12,219	\$391	\$391	\$0	\$0	\$0	CAPITAL ASSETS	1011	\$2,200	\$2,200	\$2,200
\$20,466	\$12,219	\$391	\$391	\$0	\$0	\$0	HARDWARE PURCHASES	1012	\$800	\$800	\$800
\$1,421	\$2,971	\$559	\$559	\$0	\$0	\$0	OFFICE SUPPLIES	1062	\$2,400	\$2,400	\$2,400
\$9,820	\$11,500	\$3,878	\$3,878	\$0	\$0	\$0	UTILITIES	2000	\$18,125	\$18,125	\$18,125
\$845	\$1,150	\$63	\$63	\$0	\$0	\$0	OTHER RENTALS	3020	\$2,250	\$1,125	\$1,125
\$845	\$1,150	\$63	\$63	\$0	\$0	\$0	INFORMATION TECHNOLOGY	LE3021	\$960	\$960	\$960
\$845	\$1,150	\$63	\$63	\$0	\$0	\$0	SOFTWARE PURCHASES	3040	\$235	\$235	\$235
\$3,940	\$3,760	\$1,060	\$1,060	\$0	\$0	\$0	OTHER FEES AND SERVICES	4010	\$2,725	\$2,725	\$2,725
\$2,979	\$2,700	\$0	\$0	\$0	\$0	\$0	UNIFORMS	4011	\$3,200	\$3,200	\$3,200
\$1,898	\$2,600	\$159	\$159	\$0	\$0	\$0	ANIMAL FOOD	4015	\$2,800	\$2,800	\$2,800
\$12,461	\$10,482	\$4,827	\$4,827	\$0	\$0	\$0	KENNEL SUPPLIES	4016	\$12,200	\$12,200	\$12,200
\$0	\$16,257	\$0	\$0	\$0	\$0	\$0	AUTOMOBILES	6025	\$0	\$0	\$0
\$348,264	\$352,726	\$93,379	\$93,379	\$0	\$0	\$0	TOTAL	TOTAL	\$338,688	\$350,079	\$350,346
\$348,264	\$352,726	\$93,379	\$93,379	\$0	\$0	\$0	TOTAL FOR ACTIVITY	1400	\$338,688	\$350,079	\$350,346
\$348,264	\$352,726	\$93,379	\$93,379	\$0	\$0	\$0	TOTAL FOR ORGANIZATION	0370	\$338,688	\$350,079	\$350,346
\$348,264	\$352,726	\$93,379	\$93,379	\$0	\$0	\$0	TOTAL FOR AGENCY	037	\$338,688	\$350,079	\$350,346

FUND. 010 GENERAL FUND		AGENCY: 038 TELECOMMUNICATION DIVISION		FUNC:		
ORG. 0380 TELECOMMUNICATION		ACTIVITY: 1000 GENERAL ADMINISTRATION				
1998	BUDGET AS MODIFIED	1999	TOTAL EST	BUDGET REQUEST	RECOM ENDED	ADOPTED BUDGET
EXPENDITURE	\$125,149	EXP THRU 10/22/99	EXPENDITURE	\$131,754	\$138,340	\$138,340
\$84,763		\$21,896	\$0 SALARIES AND LABOR			
\$23,409	\$18,000	\$7,110	\$0 TEMPORARY OR PART-TIME	\$30,400	\$30,400	\$30,400
\$177	\$327	\$52	\$0 LONGEVITY	\$561	\$561	\$561
\$8,016	\$10,976	\$2,171	\$0 SOCIAL SECURITY	\$12,448	\$12,952	\$12,952
\$8,509	\$15,783	\$2,382	\$0 RETIREMENT	\$17,899	\$18,623	\$18,623
\$13,650	\$16,800	\$16,800	\$0 INSURANCE(GROUP)	\$16,800	\$18,000	\$18,000
\$3,014	\$2,781	\$2,781	\$0 WORKERS COMP/UNEEMPLOYMENT	\$5,045	\$3,335	\$3,335
\$0	\$0	\$0	\$0 TRAVEL ALLOWANCE	\$0	\$0	\$0
\$2,808	\$4,500	\$288	\$0 TRAVEL REIMB/CONFERENCES	\$15,940	\$9,440	\$9,440
\$208,132	\$257,330	\$23,310	\$0 PROPERTY AND EQUIPMENT	\$8,200	\$8,200	\$8,200
\$945	\$2,500	\$15	\$0 CAPITAL ASSETS	\$0	\$0	\$0
\$945	\$2,500	\$15	\$0 OFFICE SUPPLIES	\$1,000	\$1,000	\$1,000
\$346,996	\$480,000	\$66,813	\$0 UTILITIES	\$552,000	\$552,000	\$552,000
\$32,436	\$2,200	\$375	\$0 OTHER RENTALS	\$2,240	\$2,000	\$2,000
\$32,436	\$2,200	\$375	\$0 INFORMATION TECHNOLOGY	\$1,080	\$1,080	\$1,080
\$63,495	\$95,000	\$10,982	\$0 FEES AND SERVICES	\$270,048	\$270,048	\$270,048
\$829,731	\$1,036,046	\$155,365	\$0	\$1,065,415	\$1,065,979	\$1,065,979
\$829,731	\$1,036,046	\$155,365	\$0 TOTAL FOR ACTIVITY	\$1,065,415	\$1,065,979	\$1,065,979
\$829,731	\$1,036,046	\$155,365	\$0 TOTAL FOR ORGANIZATION	\$1,065,415	\$1,065,979	\$1,065,979
\$829,731	\$1,036,046	\$155,365	\$0 TOTAL FOR AGENCY	\$1,065,415	\$1,065,979	\$1,065,979

FUND: 010 GENERAL FUND
 AGENCY: 039 BAIL BOARD BOARD OFFICE
 ORG 0390 BAIL BOARD BOARD
 ACTIVITY: 1200 ADMINISTRATION OF JUSTICE

1998	BUDGET AS MODIFIED	EXP THRU 10/22/99	TOTAL EST EXPENDITURE	ACCOUNT NAME	OBJECT	BUDGET REQUEST	RECOM ENDED	ADOPTED BUDGET
\$32,126	\$33,559	\$7,200	\$0	SALARIES AND LABOR	0200	\$33,559	\$35,236	\$35,236
\$1,672	\$4,680	\$886	\$0	TEMPORARY OR PART-TIME	0201	\$4,680	\$4,680	\$4,680
\$343	\$446	\$78	\$0	LONGEVITY	0250	\$457	\$457	\$457
\$2,471	\$2,960	\$595	\$0	SOCIAL SECURITY	0300	\$2,960	\$3,089	\$3,089
\$3,228	\$3,741	\$790	\$0	RETIREMENT	0400	\$3,742	\$3,926	\$3,926
\$4,550	\$4,200	\$4,200	\$0	INSURANCE(GROUP)	0500	\$4,200	\$4,500	\$4,500
\$1,131	\$790	\$790	\$0	WORKERS COMP/UNEMPLOYMENT0600	0600	\$1,200	\$795	\$795
\$0	\$0	\$0	\$0	TRAVEL ALLOWANCE	0700	\$0	\$0	\$0
\$789	\$600	\$150	\$0	TRAVEL REIMB/CONFERENCES	0701	\$600	\$600	\$600
\$1,774	\$1,990	\$0	\$0	PROPERTY AND EQUIPMENT	1010	\$0	\$0	\$0
\$4,035	\$4,596	\$121	\$0	OFFICE SUPPLIES	1062	\$4,596	\$4,000	\$4,000
\$4,035	\$4,596	\$121	\$0	INFORMATION TECHNOLOGY LE3021	LE3021	\$459	\$459	\$459
			\$0	FEES AND SERVICES	4010	\$150	\$150	\$150
\$56,154	\$62,158	\$14,931	\$0	TOTAL	TOTAL	\$56,603	\$57,892	\$57,892
\$56,154	\$62,158	\$14,931	\$0	TOTAL FOR ACTIVITY	1200	\$56,603	\$57,892	\$57,892
\$56,154	\$62,158	\$14,931	\$0	TOTAL FOR ORGANIZATION	0390	\$56,603	\$57,892	\$57,892
\$56,154	\$62,158	\$14,931	\$0	TOTAL FOR AGENCY	039	\$56,603	\$57,892	\$57,892

FUND. 010 GENERAL FUND
 ORG. 0400 FIRE MARSHAL
 AGENCY: 040 FIRE MARSHAL
 ACTIVITY: 1600 PUBLIC SAFETY

1998 BUDGET AS MODIFIED	1999 EXP THRU 10/22/99	TOTAL EST EXPENDITURE	ACCOUNT NAME	OBJECT	BUDGET REQUEST	*2000 RECOM ENDED	ADOPTED BUDGET	FUNC.
			SALARIES AND LABOR	0200	\$132,459	\$139,904	\$139,904	
			TEMPORARY OR PART-TIME	0201	\$25,500	\$25,500	\$25,500	
			LONGEVITY	0250	\$1,298	\$1,318	\$1,318	
			SOCIAL SECURITY	0300	\$12,183	\$12,754	\$12,754	
			RETIREMENT	0400	\$14,713	\$15,534	\$15,534	
			INSURANCE (GROUP)	0500	\$16,800	\$18,000	\$18,000	
			WORKERS COMP/UNEMPLOYMENT	0600	\$4,380	\$3,284	\$3,284	
			TRAVEL REIMB./CONFERENCES	0701	\$2,197	\$2,197	\$2,197	
			PROPERTY & EQUIPMENT	1010	\$480	\$1,330	\$1,330	
			CAPITAL ASSETS	1011	\$6,100	\$11,000	\$11,000	
			REPAIRS TO EQUIPMENT	1020	\$1,400	\$600	\$600	
			OFFICE SUPPLIES	1062	\$10,330	\$11,005	\$11,005	
			UTILITIES	2000	\$18,000	\$18,000	\$18,000	
			MATERIALS & SUPPLIES	3000	\$4,761	\$3,761	\$3,761	
			PHOTO/LAB SUPPLIES	3010	\$3,196	\$2,500	\$2,500	
			OTHER RENTALS	3020	\$2,320	\$2,000	\$2,000	
			I.T. LEASES	3021	\$0	\$1,440	\$1,440	
			FEES & SERVICES	4010	\$2,300	\$2,300	\$2,300	
			UNIFORMS	4011	\$3,440	\$2,800	\$2,800	
			OFFICERS TRAINING SUPPLIES	4013	\$1,490	\$1,240	\$1,240	
			RURAL FIRE CALLS	5020	\$994,400	\$819,400	\$819,400	
\$0	\$0	\$0	TOTAL		\$1,257,747	\$1,095,867	\$1,095,867	

EXPENSE BUDGET BY OBJECT

FUND, 010 GENERAL FUND	AGENCY: 040 FIRE MARSHAL	ACCOUNT NAME	OBJECT	1998 BUDGET AS MODIFIED	1999 EXP THRU 10/22/99	TOTAL EST EXPENDITURE	BUDGET REQUEST	RECOM ENDED	ADOPTED BUDGET
DRG, 0400 FIRE MARSHAL	1600 PUBLIC SAFETY	TOTAL FOR ACTIVITY	1600	\$0	\$0	\$0	\$1,257,747	\$1,095,867	\$1,095,867
		TOTAL FOR ORGANIZATION	0400	\$0	\$0	\$0	\$1,257,747	\$1,095,867	\$1,095,867
		TOTAL FOR AGENCY	040	\$0	\$0	\$0	\$1,257,747	\$1,095,867	\$1,095,867

** FORT BEND COUNTY **
 EXPENSE BUDGET BY OBJECT

FUND	010	GENERAL FUND	AGENCY:	042	CAPITAL OUTLAY	ACTIVITY:	2000	CAPITAL OUTLAY	FUNC.	BUDGET REQUEST	*2000 RECOM ENDED	ADOPTED BUDGET
ORG:	0420	CAPITAL OUTLAY-GENERAL FUND	042	CAPITAL OUTLAY	2000	CAPITAL OUTLAY						
1998 EXPENDITURE AS MODIFIED	BUDGET AS MODIFIED	EXP THRU 10/22/99	TOTAL EST EXPENDITURE	ACCOUNT NAME	OBJECT	BUDGET REQUEST	*2000 RECOM ENDED	ADOPTED BUDGET				
\$87,207	\$41,938	\$20,151	\$0	PROPERTY AND EQUIPMENT	1010	\$41,938	\$30,000	\$30,000				
\$3,788,936	\$1,202,511	\$75,995	\$0	PERMANENT IMPROVEMENT	1070	\$1,202,511	\$3,894,200	\$3,894,200				
\$519,300	\$500,000	\$373,417	\$0	RIGHT-OF-MAY	7009	\$500,000	\$500,000	\$500,000				
\$4,395,443	\$1,744,449	\$469,563	\$0	TOTAL	TOTAL	\$1,744,449	\$4,424,200	\$4,424,200				
\$4,395,443	\$1,744,449	\$469,563	\$0	TOTAL FOR ACTIVITY	2000	\$1,744,449	\$4,424,200	\$4,424,200				
\$4,395,443	\$1,744,449	\$469,563	\$0	TOTAL FOR ORGANIZATION	0420	\$1,744,449	\$4,424,200	\$4,424,200				
\$4,395,443	\$1,744,449	\$469,563	\$0	TOTAL FOR AGENCY	042	\$1,744,449	\$4,424,200	\$4,424,200				

FUND. 010 GENERAL FUND AGENCY: 043 ENGINEERING DEPARTMENT
 ORG. 0430 ENGINEERING ACTIVITY: 1300 ROAD AND BRIDGE MAINTENANCE FUNC.

1998	BUDGET AS MODIFIED	EXPENDITURE	10/22/99	EXP THRU	TOTAL EST	ACCOUNT NAME	OBJECT	BUDGET REQUEST	RECOM ENDED	*2000	ADOPTED BUDGET
\$514,941	\$565,979	\$88,108	10/22/99	10/22/99	EXPENDITURE		0200	\$569,329	\$592,545	\$589,718	
\$59,545	\$15,000	\$14,229			\$0	TEMPORARY OR PART-TIME	0201	\$50,000	\$50,000	\$50,000	
\$15,300	\$18,900	\$2,291			\$0	OVERTIME	0202	\$18,000	\$18,000	\$18,000	
\$4,795	\$5,851	\$836			\$0	LONGEVITY	0250	\$5,296	\$5,858	\$5,858	
\$43,648	\$46,339	\$7,990			\$0	SOCIAL SECURITY	0300	\$46,778	\$50,980	\$50,764	
\$53,497	\$64,981	\$10,168			\$0	RETIREMENT	0400	\$63,757	\$68,025	\$67,713	
\$63,700	\$58,800	\$58,800			\$0	INSURANCE(GROUP)	0500	\$58,800	\$63,000	\$63,000	
\$17,851	\$12,363	\$12,363			\$0	WORKERS COMP/UNEMPLOYMENT	0600	\$19,512	\$13,128	\$13,072	
\$0	\$0	\$0			\$0	TRAVEL ALLOWANCE	0700	\$0	\$0	\$0	
\$9,940	\$12,500	\$1,764			\$0	TRAVEL REIMB/CONFERENCES	0701	\$12,500	\$12,500	\$12,500	
\$80,277	\$91,206	\$68,710			\$0	PROPERTY AND EQUIPMENT	1010	\$22,299	\$22,229	\$22,229	
\$4,669	\$5,100	\$0			\$0	CAPITAL ASSETS	1011	\$0	\$183,826	\$183,826	
\$7,507	\$10,600	\$2,571			\$0	REPAIRS TO EQUIPMENT	1020	\$5,000	\$3,000	\$3,000	
\$21,126	\$22,500	\$3,148			\$0	OFFICE SUPPLIES	1062	\$10,600	\$10,600	\$10,600	
\$21,126	\$22,500	\$3,148			\$0	PERMANENT IMPROVMENT	1070	\$183,826	\$0	\$0	
\$1,427	\$7,800	\$0			\$0	UTILITIES	2000	\$22,500	\$20,000	\$20,000	
\$0	\$1,920	\$389			\$0	ENGINEERING SUPPLIES	2001	\$6,500	\$5,500	\$5,500	
\$0	\$0	\$0			\$0	OTHER RENTALS	3020	\$2,015	\$2,015	\$2,015	
\$38,727	\$53,073	\$16,751			\$0	I.T LEASES	3021	\$0	\$4,595	\$4,595	
\$0	\$3,500	\$476			\$0	I.T. SOFTWARE PURCHASES	3040	\$8,934	\$8,934	\$8,934	
\$191,568	\$422,187	\$79,354			\$0	OTHER FEES AND SERVICES	4010	\$42,000	\$42,000	\$42,000	
\$0	\$22,500	\$0			\$0	UNIFORMS	4011	\$3,750	\$3,750	\$3,750	
\$0	\$0	\$0			\$0	LANDFILL	4200	\$169,565	\$0	\$0	
\$0	\$0	\$0			\$0	AUTOMOBILES	6025	\$21,300	\$0	\$0	

** FORT BEND COUNTY **
 0030
 EXPENSE BUDGET BY OBJECT

FUND. 010 GENERAL FUND AGENCY: 043 ENGINEERING DEPARTMENT
 ORG 0430 ENGINEERING ACTIVITY: 1300 ROAD AND BRIDGE MAINTENANCE FUNC.

1998	BUDGET AS MODIFIED	1999 EXP THRU 10/22/99	TOTAL EST EXPENDITURE	ACCOUNT NAME	OBJECT	BUDGET REQUEST	RECOM ENDED	ADOPTED BUDGET
\$1,149,644	\$1,463,599	\$371,096	\$0	TOTL		\$1,328,327	\$1,180,485	\$1,177,074
\$1,149,644	\$1,463,599	\$371,096	\$0	TOTAL FOR ACTIVITY	1300	\$1,328,327	\$1,180,485	\$1,177,074
\$1,149,644	\$1,463,599	\$371,096	\$0	TOTAL FOR ORGANIZATION	0430	\$1,328,327	\$1,180,485	\$1,177,074

FUND 010 GENERAL FUND
 AGENCY: 045 NON-DEPARTMENTAL
 ORG 0450 NON-DEPARTMENTAL ACTIVITY: 1000 GENERAL ADMINISTRATION

1998	BUDGET AS MODIFIED	EXP THRU 10/22/99	TOTAL EST EXPENDITURE	ACCOUNT NAME	OBJECT	BUDGET REQUEST	RECOM ENDED	ADOPTED BUDGET	FUNC.
\$2,350	\$20,431	\$0	\$0	\$0 SALARIES AND LABOR	0200	\$0	\$500,000-	\$500,000-	
\$9,619	\$0	\$0	\$0	\$0 REPAIRS TO EQUIPMENT	1020	\$20,431	\$90,000	\$90,000	
\$14,774	\$13,144	\$3,377	\$3,377	\$0 MISCELLANEOUS	2020	\$0	\$0	\$0	
\$18,000	\$18,000	\$4,500	\$4,500	\$0 MATERIALS AND SUPPLIES	3000	\$13,144	\$5,000	\$5,000	
\$1,580,272	\$1,825,745	\$947,726	\$947,726	\$0 RENTAL OF PROPERTY	3070	\$18,000	\$18,000	\$18,000	
\$0	\$599,413	\$0	\$0	\$0 OTHER FEES AND SERVICES	4010	\$1,825,745	\$2,512,858	\$2,512,858	
\$0	\$0	\$0	\$0	\$0 CONTINGENCY	4040	\$1,000,000	\$1,000,000	\$1,000,000	
\$69,482	\$82,000	\$22,594	\$22,594	\$0 MERIT POOL	4070	\$0	\$0	\$0	
\$18,637	\$19,300	\$19,240	\$19,240	\$0 JURIES	4075	\$82,000	\$82,000	\$82,000	
\$464,015	\$500,000	\$122,362	\$122,362	\$0 DUES	5030	\$19,300	\$19,740	\$19,740	
\$2,177,149	\$3,078,033	\$1,119,799	\$1,119,799	\$0 CENTRAL APPRAISAL DISTRICT6030	6030	\$500,000	\$480,000	\$480,000	
\$2,177,149	\$3,078,033	\$1,119,799	\$1,119,799	TOTAL	TOTL	\$3,478,620	\$3,707,598	\$3,707,598	
				TOTAL FOR ACTIVITY	1000	\$3,478,620	\$3,707,598	\$3,707,598	

EXPENSE BUDGET BY OBJECT

FUND. 010 GENERAL FUND
 AGENCY: 045 NON-DEPARTMENTAL
 ORG 0450 NON-DEPARTMENTAL
 ACTIVITY: 4000 TRANSFER OUT
 FUNC.

1998	BUDGET AS MODIFIED	EXP THRU 10/22/99	1999 * * * * *	TOTAL EST EXPENDITURE	ACCOUNT NAME	OBJECT	BUDGET REQUEST	*2000 RECOM ENDED	ADOPTED BUDGET
\$835,044	\$898,444	\$896,269	\$0	\$896,269	OPERATING TRANSFER OUT	9200	\$898,444	\$0	\$0
\$835,044	\$898,444	\$896,269	\$0	\$896,269	TOTAL FOR ACTIVITY	4000	\$898,444	\$0	\$0
\$3,012,193	\$3,976,477	\$2,016,068	\$0	\$2,016,068	TOTAL FOR ORGANIZATION	0450	\$4,377,064	\$3,707,598	\$3,707,598
\$3,012,193	\$3,976,477	\$2,016,068	\$0	\$2,016,068	TOTAL FOR AGENCY	045	\$4,377,064	\$3,707,598	\$3,707,598
	\$835,044	\$898,444	\$0	\$898,444	TOTAL		\$898,444	\$0	\$0

** FORT ... COL ...
 EXPENSE BUDGET BY OBJECT

RUN E. 2 99
 RUN TIME. 13 54 49

FUND 010 GENERAL FUND
 ORG 0460 EMERGENCY MANAGEMENT-COUNTY
 AGENCY: 046 EMERGENCY MANAGEMENT
 ACTIVITY: 1600 PUBLIC SAFETY

BUDGET AS MODIFIED	1999 EXP THRU 10/22/99	TOTAL EST EXPENDITURE	ACCOUNT NAME	OBJECT	BUDGET REQUEST	*2000 RECOM ENDED	ADOPTED BUDGET
\$209,663	\$46,106	\$219,822	\$0 SALARIES AND LABOR	0200	\$219,822	\$109,134	\$109,134
\$21,622	\$6,098	\$25,500	\$0 TEMPORARY OR PART-TIME	0201	\$25,500	\$25,500	\$25,500
\$2,760	\$648	\$3,130	\$0 LONGEVITY	0250	\$1,298	\$1,630	\$1,630
\$17,243	\$3,922	\$19,007	\$0 SOCIAL SECURITY	0300	\$12,183	\$10,424	\$10,424
\$21,122	\$5,078	\$25,435	\$0 RETIREMENT	0400	\$14,713	\$12,184	\$12,184
\$31,850	\$29,400	\$29,400	\$0 INSURANCE(GROUP)	0500	\$16,800	\$13,500	\$13,500
\$7,228	\$5,071	\$5,071	\$0 WORKERS COMP/UNEMPLOYMENT	0600	\$4,380	\$2,684	\$2,684
\$0	\$0	\$0	\$0 TRAVEL ALLOWANCE	0700	\$0	\$0	\$0
\$5,829	\$2,595	\$7,802	\$0 TRAVEL REIMB/CONFERENCES	0701	\$2,197	\$6,000	\$6,000
\$73,599	\$2,777	\$7,562	\$0 PROPERTY AND EQUIPMENT	1010	\$480	\$21,667	\$21,667
\$73,599	\$2,777	\$7,562	\$0 CAPITAL ASSET	1011	\$6,100	\$11,325	\$11,325
\$945	\$10	\$1,665	\$0 I T. HARDWARE PURCHASES	1012	\$570	\$720	\$720
\$13,592	\$3,817	\$8,515	\$0 REPAIRS TO EQUIPMENT	1020	\$1,400	\$1,200	\$1,200
\$24,719	\$1,763	\$40,000	\$0 OFFICE SUPPLIES	1062	\$10,330	\$6,263	\$6,263
\$3,570	\$143	\$7,225	\$0 UTILITIES	2000	\$18,000	\$12,000	\$12,000
\$1,714	\$406	\$2,380	\$0 GROCERIES	2030	\$1,500	\$1,500	\$1,500
\$1,145	\$373	\$1,973	\$0 MATERIALS AND SUPPLIES	3000	\$3,486	\$3,500	\$3,500
\$5,758	\$520	\$1,449	\$0 PHOTO/LAB SUPPLIES	3010	\$3,196	\$850	\$850
\$5,758	\$520	\$1,449	\$0 OTHER RENTALS	3020	\$2,320	\$1,000	\$1,000
\$2,437	\$863	\$9,633	\$0 INFORMATION TECHNOLOGY	LE3021	\$1,440	\$1,920	\$1,920
\$1,011	\$0	\$1,200	\$0 I.T. SOFTWARE PURCHASES	3040	\$1,378	\$1,380	\$1,380
\$818,326	\$106,035	\$950,000	\$0 OTHER FEES AND SERVICES	4010	\$2,050	\$1,650	\$1,650
			\$0 UNIFORMS	4011	\$1,720	\$1,500	\$1,500
			\$0 OFFICERS TRAINING SUPPLIE	4013	\$1,240	\$0	\$0
			\$0 RURAL FIRE CALLS & EQUIPT	5020	\$994,400	\$0	\$0

FUND	ORG	010 GENERAL FUND	0520 JUSTICE OF THE PEACE #2	AGENCY: 052 JUSTICE OF THE PEACE 2	ACTIVITY: 1200 ADMINISTRATION OF JUSTICE	FUNC.			
1998	BUDGET AS MODIFIED	EXP THRU 10/22/99	1999 * * * * *	TOTAL EST EXPENDITURE	ACCOUNT NAME	OBJECT	BUDGET REQUEST	RECOM ENDED	ADOPTED BUDGET
\$129,919	\$151,210	\$55,400	\$35,400	\$0	SALARIES AND LABOR	0200	\$185,214	\$197,607	\$197,607
\$10,185	\$10,000	\$4,438	\$0	\$0	TEMPORARY OR PART-TIME	0201	\$11,600	\$0	\$0
\$2,291	\$2,458	\$526	\$0	\$0	LONGEVITY	0250	\$3,799	\$3,799	\$3,799
\$10,704	\$12,521	\$3,085	\$0	\$0	SOCIAL SECURITY	0300	\$15,347	\$15,408	\$15,408
\$13,135	\$16,904	\$3,901	\$0	\$0	RETIREMENT	0400	\$22,068	\$22,155	\$22,155
\$22,750	\$21,000	\$21,000	\$0	\$0	INSURANCE(GROUP)	0500	\$25,200	\$27,000	\$27,000
\$4,773	\$3,144	\$3,144	\$0	\$0	WORKERS COMP/UNEMPLOYMENT	0600	\$6,019	\$3,738	\$3,738
\$0	\$0	\$0	\$0	\$0	TRAVEL ALLOWANCE	0700	\$0	\$0	\$0
\$4,031	\$4,500	\$695	\$0	\$0	TRAVEL REIMB/CONFERENCES	0701	\$10,580	\$4,500	\$4,500
\$7,666	\$7,781	\$740	\$0	\$0	PROPERTY AND EQUIPMENT	1010	\$7,781	\$0	\$0
\$7,666	\$7,781	\$740	\$0	\$0	CAPITAL ASSETS	1011	\$5,200	\$5,200	\$5,200
\$7,666	\$7,781	\$740	\$0	\$0	HARDWARE PURCHASES	1012	\$2,300	\$2,000	\$2,000
\$0	\$3,830	\$0	\$0	\$0	REPAIRS TO EQUIPMENT	1020	\$0	\$0	\$0
\$5,355	\$5,366	\$362	\$0	\$0	OFFICE SUPPLIES	1062	\$7,540	\$5,400	\$5,400
\$1,737	\$5,300	\$0	\$0	\$0	UTILITIES	2000	\$0	\$0	\$0
\$2,172	\$2,190	\$222	\$0	\$0	OTHER RENTALS	3020	\$3,122	\$2,000	\$2,000
\$2,172	\$2,190	\$222	\$0	\$0	INFORMATION TECHNOLOGY	LE3021	\$1,080	\$1,080	\$1,080
\$0	\$33	\$0	\$0	\$0	OTHER FEES AND SERVICES	4010	\$1,105	\$105	\$105
\$0	\$20,999	\$0	\$0	\$0	AUTOMOBILES	6025	\$0	\$0	\$0
\$232,222	\$284,988	\$75,215	\$0	\$0	TOTAL		\$307,955	\$289,992	\$289,992
\$232,222	\$284,988	\$75,215	\$0	\$0	TOTAL FOR ACTIVITY	1200	\$307,955	\$289,992	\$289,992
\$232,222	\$284,988	\$75,215	\$0	\$0	TOTAL FOR ORGANIZATION	0520	\$307,955	\$289,992	\$289,992
\$232,222	\$284,988	\$75,215	\$0	\$0	TOTAL FOR AGENCY	052	\$307,955	\$289,992	\$289,992

** FORT BEND COUNTY **
EXPENSE BUDGET BY OBJECT

FUND. 010 GENERAL FUND
ORG 0530 PURCHASING
AGENCY: 053 PURCHASING AGENT
ACTIVITY: 1000 GENERAL ADMINISTRATION

1998 BUDGET AS MODIFIED	1999 EXP THRU 10/22/99	TOTAL EST EXPENDITURE	ACCOUNT NAME	OBJECT	BUDGET REQUEST	RECOM ENDED	ADOPTED BUDGET
\$221,591	\$248,146	\$52,917	\$0 SALARIES AND LABOR	0200	\$256,196	\$269,006	\$268,535
\$7,515	\$0	\$0	\$0 TEMPORARY OR PART-TIME	0201	\$0	\$0	\$0
\$2,887	\$3,259	\$662	\$0 LONGEVITY	0250	\$3,132	\$3,132	\$3,132
\$17,285	\$19,233	\$4,012	\$0 SOCIAL SECURITY	0300	\$19,839	\$20,819	\$20,782
\$22,320	\$27,655	\$5,818	\$0 RETIREMENT	0400	\$28,527	\$29,935	\$29,883
\$31,850	\$33,600	\$33,600	\$0 INSURANCE(GROUP)	0500	\$33,600	\$36,000	\$36,000
\$7,188	\$5,128	\$5,128	\$0 WORKERS COMP/UNEEMPLOYMENT	0600	\$8,040	\$5,361	\$5,352
\$0	\$0	\$0	\$0 TRAVEL ALLOWANCE	0700	\$0	\$0	\$0
\$11,117	\$9,460	\$1,457	\$0 TRAVEL REIMB/CONFERENCES	0701	\$12,300	\$11,000	\$11,000
\$2,603	\$13,457	\$3,145	\$0 PROPERTY AND EQUIPMENT	1010	\$0	\$0	\$0
\$84,942	\$77,000	\$7,411	\$0 REPAIRS TO EQUIPMENT	1020	\$77,000	\$7,000	\$7,000
\$4,874	\$5,300	\$1,046	\$0 OFFICE SUPPLIES	1062	\$5,600	\$5,300	\$5,300
\$1,164	\$1,400	\$165	\$0 OTHER RENTALS	3020	\$850	\$850	\$850
\$1,164	\$1,400	\$165	\$0 INFORMATION TECHNOLOGY	LE3021	\$3,006	\$3,006	\$3,006
\$1,164	\$1,400	\$165	\$0 SOFTWARE PURCHASES	3040	\$20,000	\$0	\$0
\$5,737	\$15,244	\$1,329	\$0 OTHER FEES AND SERVICES	4010	\$8,555	\$8,555	\$8,555
\$0	\$18,700	\$0	\$0 UNIFORMS	4011	\$300	\$300	\$300
\$0	\$0	\$0	\$0 AUTOMOBILES	6025	\$0	\$0	\$0
\$423,401	\$480,382	\$117,020	TOTAL	TOTAL	\$476,945	\$400,264	\$399,695
\$423,401	\$480,382	\$117,020	TOTAL FOR ACTIVITY	1000	\$476,945	\$400,264	\$399,695
\$423,401	\$480,382	\$117,020	TOTAL FOR ORGANIZATION	0530	\$476,945	\$400,264	\$399,695
\$423,401	\$480,382	\$117,020	TOTAL FOR AGENCY	053	\$476,945	\$400,264	\$399,695

FUND: 010 GENERAL FUND
 ORG: 0540 COUNTY ATTORNEY
 AGENCY: 054 COUNTY ATTORNEY
 ACTIVITY: 1200 ADMINISTRATION OF JUSTICE
 FUNC.

1998	BUDGET AS MODIFIED	EXPENDITURE	10/22/99	1999	TOTAL EST EXPENDITURE	ACCOUNT NAME	OBJECT	BUDGET REQUEST	*2000 RECOM ENDED	ADOPTED BUDGET
\$396,515	\$439,631	\$92,150	\$92,150	\$1,800	\$0	\$0 SALARIES AND LABOR	0200	\$441,440	\$460,528	\$458,348
\$0	\$2,500	\$1,800	\$1,800	\$0	\$0	TEMPORARY OR PART-TIME	0201	\$2,500	\$2,500	\$2,500
\$3,102	\$3,492	\$727	\$727	\$0	\$0	LONGEVITY	0250	\$4,083	\$3,221	\$3,221
\$29,374	\$34,091	\$7,159	\$7,159	\$0	\$0	SOCIAL SECURITY	0300	\$34,274	\$37,356	\$35,501
\$39,725	\$48,744	\$10,082	\$10,082	\$0	\$0	RETIREMENT	0400	\$49,008	\$53,406	\$50,773
\$36,400	\$37,800	\$37,800	\$37,800	\$0	\$0	INSURANCE(GROUP)	0500	\$37,800	\$40,500	\$40,500
\$11,858	\$8,534	\$8,534	\$8,534	\$0	\$0	WORKERS COMP/UNEMPLOYMENT	0600	\$13,608	\$8,887	\$8,844
\$0	\$0	\$0	\$0	\$0	\$0	TRAVEL ALLOWANCE	0700	\$0	\$0	\$0
\$9,043	\$8,500	\$2,956	\$2,956	\$0	\$0	TRAVEL REIMB/CONFERENCES	0701	\$9,000	\$8,700	\$8,700
\$1,051	\$3,291	\$254	\$254	\$0	\$0	PROPERTY AND EQUIPMENT	1010	\$690	\$690	\$690
\$17,313	\$13,424	\$1,983	\$1,983	\$0	\$0	CAPITAL ASSETS	1011	\$7,500	\$7,500	\$7,500
\$2,439	\$3,000	\$733	\$733	\$0	\$0	OFFICE SUPPLIES	1062	\$3,200	\$3,000	\$3,000
\$17,313	\$13,424	\$1,983	\$1,983	\$0	\$0	LAW BOOKS	1063	\$12,930	\$12,930	\$12,930
\$0	\$1,585	\$301	\$301	\$0	\$0	OTHER RENTALS	3020	\$1,585	\$1,088	\$1,088
\$0	\$1,585	\$301	\$301	\$0	\$0	INFORMATION TECHNOLOGY	LE3021	\$1,920	\$1,920	\$1,920
\$0	\$1,585	\$301	\$301	\$0	\$0	ELECTION EXPENSES	3030	\$0	\$0	\$0
\$0	\$1,585	\$301	\$301	\$0	\$0	SOFTWARE PURCHASE	3040	\$868	\$868	\$868
\$5,728	\$10,840	\$1,549	\$1,549	\$0	\$0	OTHER FEES AND SERVICES	4010	\$7,630	\$7,630	\$7,630
\$569,861	\$633,611	\$168,914	\$168,914	\$0	\$0	TOTL	TOTL	\$628,036	\$650,724	\$644,013
\$569,861	\$633,611	\$168,914	\$168,914	\$0	\$0	TOTAL FOR ACTIVITY	1200	\$628,036	\$650,724	\$644,013
\$569,861	\$633,611	\$168,914	\$168,914	\$0	\$0	TOTAL FOR ORGANIZATION	0540	\$628,036	\$650,724	\$644,013
\$569,861	\$633,611	\$168,914	\$168,914	\$0	\$0	TOTAL FOR AGENCY	054	\$628,036	\$650,724	\$644,013

FUND. 010 GENERAL FUND
 AGENCY: 055 COUNTY COURT AT LAW 2
 ORG: 0550 COUNTY COURT AT LAW #2 ACTIVITY: 1200 ADMINISTRATION OF JUSTICE FUNC.

1998 EXPENDITURE \$225,664	BUDGET AS MODIFIED \$234,804	1999 EXP THRU 10/22/99 \$55,109	TOTAL EST EXPENDITURE	ACCOUNT NAME	OBJECT	BUDGET REQUEST \$237,853	RECOM ENDED \$244,263	ADOPTED BUDGET \$243,879
\$80	\$500	\$0	\$0	\$0 TEMPORARY OR PART-TIME	0201	\$500	\$500	\$500
\$3,314	\$3,538	\$744	\$0	\$0 LONGEVITY	0250	\$3,776	\$3,776	\$3,776
\$14,390	\$18,567	\$4,101	\$0	\$0 SOCIAL SECURITY	0300	\$18,818	\$19,308	\$19,279
\$23,059	\$26,642	\$6,152	\$0	\$0 RETIREMENT	0400	\$27,004	\$27,708	\$27,666
\$18,200	\$16,800	\$16,800	\$0	\$0 INSURANCE(GROUP)	0500	\$16,800	\$18,000	\$18,000
\$6,648	\$4,500	\$4,500	\$0	\$0 WORKERS COMP/UNEMPLOYMENT	0600	\$7,120	\$4,497	\$4,490
\$3,101	\$3,856	\$800	\$0	\$0 TRAVEL ALLOWANCE	0700	\$3,856	\$3,840	\$3,840
\$766	\$4,000	\$100	\$0	\$0 TRAVEL REIMB/CONFERENCES	0701	\$3,600	\$3,600	\$3,600
\$120	\$0	\$0	\$0	\$0 PROPERTY AND EQUIPMENT	1010	\$0	\$0	\$0
\$120	\$0	\$0	\$0	\$0 HARDWARE PURCHASES	1012	\$2,190	\$2,190	\$2,190
\$5,935	\$5,731	\$708	\$0	\$0 OFFICE SUPPLIES	1062	\$6,500	\$6,500	\$6,500
\$0	\$1,080	\$143	\$0	\$0 LAW BOOKS	1063	\$3,500	\$3,500	\$3,500
\$518	\$545	\$0	\$0	\$0 OTHER RENTALS	3020	\$600	\$0	\$0
\$518	\$545	\$0	\$0	\$0 INFORMATION TECHNOLOGY	LE3021	\$2,400	\$2,400	\$2,400
\$87,530	\$101,300	\$10,331	\$0	\$0 OTHER FEES AND SERVICES	4010	\$101,300	\$101,900	\$101,900
\$389,963	\$422,408	\$99,488	\$0	TOTAL	TOTAL	\$435,817	\$441,982	\$441,520
\$389,963	\$422,408	\$99,488	\$0	TOTAL FOR ACTIVITY	1200	\$435,817	\$441,982	\$441,520
\$389,963	\$422,408	\$99,488	\$0	TOTAL FOR ORGANIZATION	0550	\$435,817	\$441,982	\$441,520
\$389,963	\$422,408	\$99,488	\$0	TOTAL FOR AGENCY	055	\$435,817	\$441,982	\$441,520

FUND. 010 GENERAL FUND		AGENCY: 056 COUNTY COURT AT LAW 3		ACTIVITY: 1200 ADMINISTRATION OF JUSTICE		FUNC:	
ORG. 0560 COUNTY COURT AT LAW \$3							
1998	BUDGET	1999	TOTAL EST	ACCOUNT NAME	OBJECT	BUDGET	RECOM
EXPENDITURE AS MODIFIED		EXP THRU	EXPENDITURE			REQUEST	ENDED
\$220,686	\$232,120	10/22/99	\$54,350	\$0 SALARIES AND LABOR	0200	\$237,853	\$244,263
				\$0 TEMPORARY OR PART-TIME	0201	\$500	\$500
				\$0 LONGEVITY	0250	\$934	\$934
\$14,353	\$18,144	\$4,200	\$4,200	\$0 SOCIAL SECURITY	0300	\$18,601	\$19,091
\$22,188	\$26,033	\$6,000	\$6,000	\$0 RETIREMENT	0400	\$26,691	\$27,396
\$18,200	\$16,800	\$16,800	\$16,800	\$0 INSURANCE(GROUP)	0500	\$16,800	\$18,000
\$6,444	\$4,389	\$4,389	\$4,389	\$0 WORKERS COMP/UNEMPLOYMENT	0600	\$7,035	\$4,453
\$3,101	\$3,856	\$800	\$800	\$0 TRAVEL ALLOWANCE	0700	\$3,856	\$3,840
\$3,374	\$4,000	\$342	\$342	\$0 TRAVEL REIMB/CONFERENCES	0701	\$4,600	\$4,600
\$0	\$0	\$0	\$0	\$0 PROPERTY AND EQUIPMENT	1010	\$0	\$0
\$5,057	\$5,609	\$695	\$695	\$0 OFFICE SUPPLIES	1062	\$4,000	\$4,000
\$0	\$1,580	\$0	\$0	\$0 LAW BOOKS	1063	\$3,500	\$3,500
\$488	\$1,250	\$4	\$4	\$0 OTHER RENTALS	3020	\$700	\$700
\$162,102	\$101,300	\$21,344	\$21,344	\$0 INFORMATION TECHNOLOGY	LE3021	\$960	\$960
\$162,102	\$101,300	\$21,344	\$21,344	\$0 OTHER FEES AND SERVICES	4010	\$101,300	\$101,300
\$618,716	\$517,579	\$130,409	\$130,409	\$0	TOTL	\$427,330	\$433,537
\$618,716	\$517,579	\$130,409	\$130,409	\$0	TOTAL FOR ACTIVITY	\$427,330	\$433,537
\$618,716	\$517,579	\$130,409	\$130,409	\$0	TOTAL FOR ORGANIZATION	\$427,330	\$433,537
\$618,716	\$517,579	\$130,409	\$130,409	\$0	TOTAL FOR AGENCY	\$427,330	\$433,537

FUND 010 GENERAL FUND
ORG. 0580 ASSOCIATE COUNTY COURT AT LAW

AGENCY: 058 ASSOCIATE COUNTY COURT-AT-LAW
ACTIVITY: 1200 ADMINISTRATION OF JUSTICE
FUND.

1998 BUDGET AS MODIFIED	EXP THRU 10/22/99	1999 EXP THRU 10/22/99	TOTAL EST EXPENDITURE	ACCOUNT NAME	OBJECT	BUDGET REQUEST	*2000 RECOM ENDED	ADOPTED BUDGET
\$0	\$0	\$0	\$0	\$0 SALARIES AND LABOR	0200	\$71,662	\$75,245	\$74,162
\$0	\$0	\$0	\$0	\$0 TEMPORARY OR PART-TIME	0201	\$0	\$0	\$0
\$0	\$0	\$0	\$0	\$0 LONGEVITY	0250	\$33	\$33	\$33
\$0	\$0	\$0	\$0	\$0 SOCIAL SECURITY	0300	\$5,487	\$5,759	\$5,676
\$0	\$0	\$0	\$0	\$0 RETIREMENT	0400	\$7,889	\$8,280	\$8,161
\$0	\$0	\$0	\$0	\$0 INSURANCE (GROUP)	0500	\$4,200	\$4,500	\$4,500
\$0	\$0	\$0	\$0	\$0 WORKERS COMP/UNEMPLOYMENT0600	0600	\$1,998	\$1,483	\$1,462
\$0	\$0	\$0	\$0	\$0 TRAVEL REIMB.CONFERENCES 0701	0701	\$1,600	\$1,600	\$1,600
\$0	\$0	\$0	\$0	\$0 PROPERTY & EQUIPMENT	1010	\$0	\$0	\$0
\$0	\$0	\$0	\$0	\$0 OFFICE SUPPLIES	1062	\$6,500	\$4,000	\$4,000
\$0	\$0	\$0	\$0	\$0 LAW BOOKS	1063	\$3,500	\$3,500	\$3,500
\$0	\$0	\$0	\$0	\$0 OTHER RENTALS	3020	\$545	\$545	\$545
\$0	\$0	\$0	\$0	\$0 I T. LEASES	3021	\$480	\$480	\$480
\$0	\$0	\$0	\$0	\$0 OTHER FEES AND SERVICES	4010	\$1,300	\$1,300	\$1,300
\$0	\$0	\$0	\$0	TOTAL	TOTAL	\$105,194	\$106,725	\$105,419
\$0	\$0	\$0	\$0	TOTAL FOR ACTIVITY	1200	\$105,194	\$106,725	\$105,419
\$0	\$0	\$0	\$0	TOTAL FOR ORGANIZATION	0580	\$105,194	\$106,725	\$105,419
\$0	\$0	\$0	\$0	TOTAL FOR AGENCY	058	\$105,194	\$106,725	\$105,419

FUND. 010 GENERAL FUND		AGENCY: 065 DEPARTMENT OF PUBLIC SAFETY		FUNC.					
ORG. 0650 DEPT OF PUBLIC SAFETY		ACTIVITY: 1600 PUBLIC SAFETY							
1998	BUDGET AS MODIFIED	1999	EXP THRU	TOTAL EST	ACCOUNT NAME	OBJECT	BUDGET REQUEST	RECOM ENDED	ADOPTED BUDGET
\$23,122	\$24,036	\$5,157	10/22/99	EXPENDITURE	\$0 SALARIES AND LABOR	0200	\$24,035	\$25,236	\$25,236
\$6,854	\$8,801	\$1,528		\$0	TEMPORARY OR PART-TIME	0201	\$8,801	\$8,801	\$8,801
\$410	\$464	\$90		\$0	LONGEVITY	0250	\$522	\$522	\$522
\$2,184	\$2,512	\$482		\$0	SOCIAL SECURITY	0300	\$2,552	\$2,644	\$2,644
\$2,339	\$2,644	\$570		\$0	RETIREMENT	0400	\$2,702	\$2,833	\$2,833
\$4,550	\$4,200	\$4,200		\$0	INSURANCE(GROUP)	0500	\$4,200	\$4,500	\$4,500
\$986	\$680	\$680		\$0	WORKERS COMP/UNEMPLOYMENT	0600	\$1,035	\$681	\$681
\$18,514	\$8,622	\$259		\$0	PROPERTY AND EQUIPMENT	1010	\$400	\$400	\$400
\$18,514	\$8,622	\$259		\$0	CAPITAL ASSETS	1011	\$5,990	\$2,995	\$2,995
\$18,514	\$8,622	\$259		\$0	HARDWARE PURCHASES	1012	\$2,500	\$2,500	\$2,500
\$0	\$0	\$0		\$0	OFFICE SUPPLIES	1062	\$1,200	\$0	\$0
\$0	\$0	\$0		\$0	UTILITIES	2000	\$0	\$0	\$0
\$0	\$0	\$0		\$0	OTHER RENTALS	3020	\$0	\$0	\$0
\$0	\$0	\$0		\$0	INFORMATION TECHNOLOGY	LE3021	\$2,160	\$2,160	\$2,160
\$0	\$0	\$0		\$0	FEES AND SERVICES	4010	\$0	\$0	\$0
\$95,987	\$69,203	\$13,484		\$0	TOTAL	TOTAL	\$56,097	\$53,272	\$53,272
\$95,987	\$69,203	\$13,484		\$0	TOTAL FOR ACTIVITY	1600	\$56,097	\$53,272	\$53,272
\$95,987	\$69,203	\$13,484		\$0	TOTAL FOR ORGANIZATION	0650	\$56,097	\$53,272	\$53,272

EXPENSE BUDGET BY OBJECT

FUND. 010 GENERAL FUND
 ORG 0651 DPS - LICENSE AND WEIGHT

AGENCY: 065 DEPARTMENT OF PUBLIC SAFETY
 ACTIVITY: 1600 PUBLIC SAFETY

1998 EXPENDITURE AS MODIFIED \$0	BUDGET \$700	1999 EXP THRU 10/22/99 \$0	TOTAL EST EXPENDITURE \$0	ACCOUNT NAME	OBJECT	BUDGET REQUEST \$1,200	2000 RECOM ENDED \$1,200	ADOPTED BUDGET \$1,200	FUNC.
\$0	\$1,963	\$463	\$0	OFFICE SUPPLIES	1062	\$0	\$0	\$0	
\$0	\$2,337	\$36	\$0	OTHER RENTALS	3020	\$4,186	\$4,186	\$4,186	
\$3,141	\$186	\$0	\$0	FEES AND SERVICES	4010	\$0	\$0	\$0	
\$3,141	\$5,186	\$499	\$0	TOTAL	TOTL	\$5,386	\$5,386	\$5,386	
\$3,141	\$5,186	\$499	\$0	TOTAL FOR ACTIVITY	1600	\$5,386	\$5,386	\$5,386	
\$3,141	\$5,186	\$499	\$0	TOTAL FOR ORGANIZATION	0651	\$5,386	\$5,386	\$5,386	
\$99,128	\$74,389	\$13,983	\$0	TOTAL FOR AGENCY	065	\$61,483	\$58,658	\$58,658	

EXPENSE BUDGET BY OBJECT

FUND	010 GENERAL FUND	0680 RISK MANAGEMENT/INSURANCE	1999 EXP THRU 10/22/99	BUDGET AS MODIFIED	TOTAL EST EXPENDITURE	ACCOUNT NAME	OBJECT	BUDGET REQUEST	*2000 RECOM ENDED	ADOPTED BUDGET
ORG	0680 RISK MANAGEMENT/INSURANCE		\$23,503	\$110,742	\$134,245	\$0 SALARIES AND LABOR	0200	\$152,742	\$180,379	\$180,379
			\$0	\$0	\$0	\$0 TEMPORARY OR PART-TIME	0201	\$0	\$0	\$0
			\$439	\$2,070	\$2,509	\$0 LONGEVITY	0250	\$2,444	\$2,444	\$2,444
			\$1,789	\$8,630	\$10,419	\$0 SOCIAL SECURITY	0300	\$11,872	\$12,456	\$12,456
			\$2,601	\$12,409	\$15,010	\$0 RETIREMENT	0400	\$17,071	\$17,911	\$17,911
			\$16,800	\$16,800	\$33,600	\$0 INSURANCE(GROUP)	0500	\$21,000	\$22,500	\$22,500
			\$570,000	\$570,000	\$1,140,000	\$0 INSURANCE(GROUP/RET)	0501	\$575,000	\$575,000	\$575,000
			\$499,764	\$499,764	\$999,528	\$0 INSURANCE(PROPERTY)	0550	\$1,350,000	\$1,350,000	\$1,350,000
			\$2,507	\$2,507	\$5,014	\$0 WORKERS COMP/UNEEMPLOYMENT	0600	\$4,812	\$3,208	\$3,208
			\$25	\$2,500	\$2,525	\$0 TRAVEL REIMB/CONFERENCES	0701	\$4,000	\$2,500	\$2,500
			\$99	\$4,624	\$4,723	\$0 PROPERTY AND EQUIPMENT	1010	\$4,624	\$7,250	\$7,250
			\$99	\$4,624	\$4,723	\$0 CAPITAL ASSETS	1011	\$12,500	\$9,000	\$9,000
			\$99	\$4,624	\$4,723	\$0 HARDWARE PURCHASES	1012	\$1,584	\$380	\$380
			\$1,714	\$10,373	\$12,087	\$0 OFFICE SUPPLIES	1062	\$12,500	\$9,000	\$9,000
			\$0	\$0	\$0	\$0 MATERIALS AND SUPPLIES	3000	\$0	\$0	\$0
			\$86	\$1,000	\$1,086	\$0 OTHER RENTALS	3020	\$1,200	\$1,000	\$1,000
			\$12,020	\$168,125	\$180,145	\$0 INFORMATION TECHNOLOGY	LE3021	\$540	\$480	\$480
			\$0	\$0	\$0	\$0 I T HARDWARE PURCHASES	3040	\$284	\$284	\$284
			\$0	\$0	\$0	\$0 OTHER FEES AND SERVICES	4010	\$521,050	\$521,050	\$521,050
			\$12,020	\$168,125	\$180,145	\$0 AUTOMOBILES	6025	\$19,600	\$19,600	\$19,600
			\$0	\$8,000	\$8,000	\$0 SAFETY PROGRAMS	7014	\$15,000	\$15,000	\$15,000
			\$1,143,565	\$1,594,917	\$2,738,482	TOTAL	TOTAL	\$2,727,823	\$2,749,442	\$2,749,442

** FOR ILLINOIS COUNTY **
 EXPENSE BUDGET BY OBJECT

FUND	ORG	010 GENERAL FUND	0690 ELECTIONS ADMINISTRATOR	AGENCY	069 ELECTIONS ADMINISTRATION	ACTIVITY	1000 GENERAL ADMINISTRATION	ACCOUNT NAME	OBJECT	BUDGET AS MODIFIED	EXPENDITURE	10/22/99	EXPENDITURE	TOTAL EST	BUDGET REQUEST	RECOM ENDED	ADOPTED BUDGET
								\$0 SALARIES AND LABOR	0200	\$155,567	\$34,336	\$34,336	\$34,336	\$180,123	\$189,129	\$189,129	
							\$0 LONGEVITY		0250	\$1,041	\$268	\$268	\$268	\$1,620	\$1,620	\$1,620	
							\$0 SOCIAL SECURITY		0300	\$13,908	\$2,625	\$2,625	\$2,625	\$13,905	\$14,592	\$14,592	
							\$0 RETIREMENT		0400	\$15,571	\$3,756	\$3,756	\$3,756	\$19,993	\$20,982	\$20,982	
							\$0 INSURANCE(GROUP)		0500	\$22,750	\$21,000	\$21,000	\$21,000	\$25,200	\$27,000	\$27,000	
							\$0 WORKERS COMP/UNEMPLOYMENT		0600	\$4,675	\$3,313	\$3,313	\$3,313	\$5,639	\$3,758	\$3,758	
							\$0 TRAVEL REIMB./CONFERENCES		0701					\$4,300	\$4,000	\$4,000	
							\$0 PROPERTY AND EQUIPMENT		1010	\$4,452	\$0	\$0	\$0	\$5,280	\$11,625	\$11,625	
							\$0 CAPITOL ASSETS		1011	\$4,452	\$0	\$0	\$0	\$18,200	\$8,300	\$8,300	
							\$0 OFFICE SUPPLIES		1062	\$10,343	\$1,419	\$1,419	\$1,419	\$11,170	\$11,170	\$11,170	
							\$0 OTHER RENTALS		3020	\$0	\$400	\$400	\$400	\$4,720	\$4,720	\$4,720	
							\$0 I.T. LEASES		3021					\$3,240	\$3,240	\$3,240	
							\$0 ELECTION EXPENSES		3030	\$168,349	\$27,452	\$27,452	\$27,452	\$219,300	\$219,300	\$219,300	
							\$0 OTHER FEES AND SERVICES		4010	\$5,504	\$220	\$220	\$220	\$30,975	\$30,975	\$30,975	
								TOTAL		\$406,612	\$94,789	\$94,789	\$94,789	\$543,665	\$550,411	\$550,411	
								TOTAL FOR ACTIVITY	1000	\$406,612	\$94,789	\$94,789	\$94,789	\$543,665	\$550,411	\$550,411	
								TOTAL FOR ORGANIZATION	0690	\$406,612	\$94,789	\$94,789	\$94,789	\$543,665	\$550,411	\$550,411	
								TOTAL FOR AGENCY	069	\$406,612	\$94,789	\$94,789	\$94,789	\$543,665	\$550,411	\$550,411	

FUND. 010 GENERAL FUND
 AGENCY. 070 PARKS DEPARTMENT
 ORG 0700 PARKS DEPARTMENT ACTIVITY. 1700 PARKS AND RECREATION

1998 EXPENDITURE	BUDGET AS MODIFIED	1999 EXP THRU 10/22/99	TOTAL EST EXPENDITURE	ACCOUNT NAME	OBJECT	BUDGET REQUEST	*2000 RECOM ENDED	ADOPTED BUDGET
\$329,118	\$372,860	\$69,519	\$0	SALARIES AND LABOR	0200	\$403,379	\$393,978	\$391,947
\$37,753	\$38,000	\$4,847	\$0	TEMPORARY OR PART-TIME	0201	\$50,000	\$80,000	\$80,000
\$14,938	\$15,000	\$2,222	\$0	OVERTIME	0202	\$20,000	\$20,000	\$20,000
\$3,757	\$4,563	\$801	\$0	LONGEVITY	0250	\$4,623	\$4,614	\$4,614
\$29,104	\$32,928	\$5,823	\$0	SOCIAL SECURITY	0300	\$37,945	\$38,142	\$37,987
\$34,884	\$47,347	\$7,866	\$0	RETIREMENT	0400	\$51,261	\$52,535	\$52,312
\$54,600	\$54,600	\$54,600	\$0	INSURANCE(GROUP)	0500	\$58,800	\$58,500	\$58,500
\$12,104	\$8,436	\$8,436	\$0	WORKERS COMP/UNEMPLOYMENT	0600	\$15,377	\$9,822	\$9,782
\$1,219	\$2,500	\$388	\$0	TRAVEL REIMB/CONFERENCES	0701	\$4,000	\$2,800	\$2,800
\$74,824	\$80,774	\$56,186	\$0	PROPERTY AND EQUIPMENT	1010	\$6,000	\$4,000	\$4,000
\$5,387	\$4,061	\$118	\$0	CAPITAL ASSETS	1011	\$7,500	\$7,500	\$7,500
\$5,387	\$4,061	\$118	\$0	OFFICE SUPPLIES	1062	\$10,500	\$5,500	\$5,500
\$4,745	\$13,000	\$0	\$0	MEDICAL SUPPLIES	1065	\$800	\$400	\$400
\$4,745	\$13,000	\$0	\$0	PERMANENT IMPROVEMENT	1070	\$0	\$0	\$0
\$27,857	\$36,610	\$3,668	\$0	UTILITIES	2000	\$40,500	\$40,500	\$40,500
\$27,857	\$36,610	\$3,668	\$0	JANITORIAL & PETS CONTROL	2060	\$1,200	\$800	\$800
\$0	\$2,000	\$0	\$0	MATERIALS	3000	\$6,500	\$3,000	\$3,000
\$5,550	\$7,000	\$1,085	\$0	OTHER RENTALS	3020	\$9,900	\$7,500	\$7,500
\$37,849	\$19,788	\$3,981	\$0	OTHER FEES AND SERVICES	4010	\$26,000	\$21,000	\$21,000
\$3,640	\$3,500	\$365	\$0	UNIFORMS	4011	\$5,500	\$4,000	\$4,000
\$0	\$0	\$0	\$0	AUTOMOBILES	6025	\$14,400	\$17,400	\$17,400
\$0	\$0	\$0	\$0	LUMBER & HARDWARE	7003	\$4,000	\$2,000	\$2,000
\$1,782	\$2,691	\$0	\$0	TIRES AND TUBES	7006	\$2,500	\$0	\$0
\$34,625	\$30,117	\$3,697	\$0	REPAIRS & PARTS/SHOP SUPPT	7007	\$39,000	\$15,000	\$15,000
		\$0	\$0	REPAIRS - BUILDINGS	7012	\$0	\$15,000	\$15,000

** PORT COUNTY *
 EXPENSE BUDGET BY OBJECT

FUND	010 GENERAL FUND	AGENCY, 071 COMMISSIONER PRECINCT 1	0710 COMMISSIONER PRECINCT 1	1998 BUDGET AS MODIFIED	EXP THRU 10/22/99	TOTAL EST EXPENDITURE	ACCOUNT NAME	OBJECT	BUDGET REQUEST	RECOM ENDED	ADOPTED BUDGET	FUNC
ORG	0710 COMMISSIONER PRECINCT 1	AGENCY, 071 COMMISSIONER PRECINCT 1	ACTIVITY: 1000 GENERAL ADMINISTRATION	\$138,769	\$33,747	\$0	\$0 SALARIES AND LABOR	0200	\$145,620	\$154,489	\$154,489	
				\$816	\$48	\$0	\$0 TEMPORARY OR PART-TIME	0201	\$21,000	\$21,000	\$21,000	
				\$1,612	\$380	\$0	\$0 LONGEVITY	0250	\$1,316	\$1,316	\$1,316	
				\$10,462	\$2,538	\$0	\$0 SOCIAL SECURITY	0300	\$12,848	\$13,526	\$13,526	
				\$13,949	\$3,705	\$0	\$0 RETIREMENT	0400	\$16,163	\$17,138	\$17,138	
				\$13,650	\$12,600	\$0	\$0 INSURANCE(GROUP)	0500	\$12,600	\$13,500	\$13,500	
				\$4,228	\$2,809	\$0	\$0 WORKERS COMP/UNEEMPLOYMENT0600		\$4,969	\$3,228	\$3,228	
				\$5,988	\$985	\$0	\$0 TRAVEL REIMB/CONFERENCES	0701	\$6,000	\$6,000	\$6,000	
				\$2,437	\$0	\$0	\$0 PROPERTY AND EQUIPMENT	1010	\$0	\$0	\$0	
				\$1,479	\$183	\$0	\$0 OFFICE SUPPLIES	1062	\$2,000	\$2,000	\$2,000	
				\$4,084	\$545	\$0	\$0 UTILITIES	2000	\$4,000	\$4,000	\$4,000	
				\$0	\$353	\$0	\$0 OTHER RENTALS	3020	\$3,000	\$3,000	\$3,000	
				\$3,908	\$0	\$0	\$0 INFORMATION TECHNOLOGY	LE3021	\$480	\$480	\$480	
				\$3,908	\$0	\$0	\$0 FEES AND SERVICES	4010	\$6,000	\$5,000	\$5,000	
				\$205,290	\$57,893	\$0	TOTL		\$235,996	\$244,677	\$244,677	
				\$205,290	\$57,893	\$0	TOTAL FOR ACTIVITY	1000	\$235,996	\$244,677	\$244,677	
				\$205,290	\$57,893	\$0	TOTAL FOR ORGANIZATION	0710	\$235,996	\$244,677	\$244,677	
				\$205,290	\$57,893	\$0	TOTAL FOR AGENCY	071	\$235,996	\$244,677	\$244,677	

EXPENSE BUDGET BY OBJECT

FUND	010	GENERAL FUND	AGENCY	072	COMMISSIONER PRECINCT 2	OBJECT	BUDGET REQUEST	2000 RECOM ENDED	ADOPTED BUDGET
ORG	0720	COMMISSIONER PRECINCT 2	ACTIVITY	1000	GENERAL ADMINISTRATION	0200	\$230,135	\$240,300	\$240,300
1998 EXPENDITURE AS MODIFIED	EXP THRU 10/22/99	TOTAL EST EXPENDITURE	ACCOUNT NAME						
\$219,073	\$51,875	\$0	\$0 SALARIES AND LABOR						
\$13,220	\$1,845	\$0	\$0 TEMPORARY OR PART-TIME				\$15,000	\$15,000	\$15,000
\$2,032	\$486	\$0	\$0 LONGEVITY				\$2,622	\$2,321	\$2,321
\$17,508	\$4,040	\$0	\$0 SOCIAL SECURITY				\$18,954	\$19,708	\$19,708
\$23,289	\$5,884	\$0	\$0 RETIREMENT				\$27,253	\$28,338	\$28,338
\$22,750	\$21,000	\$0	\$0 INSURANCE(GROUP)				\$21,000	\$22,500	\$22,500
\$7,057	\$4,807	\$0	\$0 WORKERS COMP/UNEEMPLOYMENT				\$7,443	\$4,824	\$4,824
\$7,532	\$3,901	\$0	\$0 TRAVEL REIMB/CONFERENCES				\$10,000	\$10,000	\$10,000
\$551	\$3,360	\$0	\$0 PROPERTY AND EQUIPMENT				\$2,000	\$2,000	\$2,000
\$14,370	\$2,975	\$0	\$0 OFFICE SUPPLIES				\$15,350	\$14,800	\$14,800
\$540	\$0	\$0	\$0 UTILITIES				\$800	\$800	\$800
\$0	\$362	\$0	\$0 OTHER RENTALS				\$2,800	\$2,800	\$2,800
\$16,830	\$372	\$0	\$0 FEES AND SERVICES				\$10,000	\$10,000	\$10,000
\$344,752	\$100,907	\$0	TOTAL				\$363,357	\$373,391	\$373,391
\$344,752	\$100,907	\$0	TOTAL FOR ACTIVITY				\$363,357	\$373,391	\$373,391
\$344,752	\$100,907	\$0	TOTAL FOR ORGANIZATION				\$363,357	\$373,391	\$373,391
\$344,752	\$100,907	\$0	TOTAL FOR AGENCY				\$363,357	\$373,391	\$373,391

** COUNTY COMMISSIONERS
 EXPENSE BUDGET BY OBJECT

FUND	010 GENERAL FUND	0730 COMMISSIONER PRECINCT 3	1999	EXP THRU	TOTAL EST	ACCOUNT NAME	OBJECT	BUDGET	RECOM	ADOPTED
EXPENDITURE	AS MODIFIED	10/22/99	EXPENDITURE					REQUEST	ENDED	BUDGET
\$152,820	\$180,125	\$41,639	\$0	\$0	\$0	\$0	\$0	\$185,365	\$190,950	\$190,950
\$618	\$5,000	\$0	\$0	\$0	\$0	TEMPORARY OR PART-TIME	0201	\$1,500	\$1,500	\$1,500
\$460	\$424	\$128	\$128	\$0	\$0	LONGEVITY	0250	\$866	\$866	\$866
\$11,611	\$14,195	\$3,127	\$3,127	\$0	\$0	SOCIAL SECURITY	0300	\$14,362	\$14,789	\$14,789
\$15,236	\$19,861	\$4,533	\$4,533	\$0	\$0	RETIREMENT	0400	\$20,486	\$21,100	\$21,100
\$18,200	\$16,800	\$16,800	\$16,800	\$0	\$0	INSURANCE(GROUP)	0500	\$16,800	\$18,000	\$18,000
\$5,241	\$3,552	\$3,552	\$3,552	\$0	\$0	WORKERS COMP/UNEMPLOYMENT	0600	\$5,585	\$3,563	\$3,563
\$7,883	\$8,000	\$1,573	\$1,573	\$0	\$0	TRAVEL REIMB/CONFERENCES	0701	\$13,700	\$11,700	\$11,700
\$6,947	\$4,500	\$0	\$0	\$0	\$0	PROPERTY AND EQUIPMENT	1010	\$4,000	\$4,000	\$4,000
\$3,658	\$2,315	\$976	\$976	\$0	\$0	OFFICE SUPPLIES	1062	\$11,250	\$11,250	\$11,250
\$8,544	\$9,500	\$1,663	\$1,663	\$0	\$0	UTILITIES	2000	\$9,700	\$9,700	\$9,700
\$0	\$4,700	\$336	\$336	\$0	\$0	OTHER RENTALS	3020	\$3,200	\$3,200	\$3,200
\$5,322	\$5,913	\$459	\$459	\$0	\$0	FEES AND SERVICES	4010	\$9,400	\$9,400	\$9,400
\$236,540	\$274,885	\$74,786	\$74,786	\$0	\$0	TOTL		\$296,214	\$300,018	\$300,018
\$236,540	\$274,885	\$74,786	\$74,786	\$0	\$0	TOTAL FOR ACTIVITY	1000	\$296,214	\$300,018	\$300,018
\$236,540	\$274,885	\$74,786	\$74,786	\$0	\$0	TOTAL FOR ORGANIZATION	0730	\$296,214	\$300,018	\$300,018
\$236,540	\$274,885	\$74,786	\$74,786	\$0	\$0	TOTAL FOR AGENCY	073	\$296,214	\$300,018	\$300,018

EXPENSE BUDGET BY OBJECT

FUND	ORG	010 GENERAL FUND	074 COMMISSIONER PRECINCT 4	AGENCY	074 COMMISSIONER PRECINCT 4	ACTIVITY	1000 GENERAL ADMINISTRATION	ACCOUNT NAME	OBJECT	BUDGET REQUEST	*2000 RECOM ENDED	*ADOPTED BUDGET	
1998									0200	\$168,841	\$182,457	\$182,457	
								\$0 SALARIES AND LABOR					
								\$0 TEMPORARY OR PART-TIME	0201	\$2,500	\$2,500	\$2,500	
								\$0 LONGEVITY	0250	\$1,729	\$1,729	\$1,729	
								\$0 SOCIAL SECURITY	0300	\$13,240	\$14,281	\$14,281	
								\$0 RETIREMENT	0400	\$18,763	\$20,260	\$20,260	
								\$0 INSURANCE(GROUP)	0500	\$16,800	\$18,000	\$18,000	
								\$0 WORKERS COMP/UNEMPLOYMENT	0600	\$3,297	\$3,435	\$3,435	
								\$0 TRAVEL REIMB/CONFERENCES	0701	\$9,500	\$9,500	\$9,500	
								\$0 PROPERTY AND EQUIPMENT	1010	\$4,600	\$4,600	\$4,600	
								\$0 OFFICE SUPPLIES	1062	\$2,000	\$2,000	\$2,000	
								\$0 UTILITIES	2000	\$7,000	\$7,000	\$7,000	
								\$0 OTHER RENTALS	3020	\$2,600	\$2,600	\$2,600	
								\$0 I T LEASES	3021	\$480	\$480	\$480	
								\$0 FEES AND SERVICES	4010	\$18,310	\$8,900	\$8,900	
									TOTL	\$269,660	\$277,742	\$277,742	
									TOTAL FOR ACTIVITY	1000	\$269,660	\$277,742	\$277,742
									TOTAL FOR ORGANIZATION	0740	\$269,660	\$277,742	\$277,742
									TOTAL FOR AGENCY	074	\$269,660	\$277,742	\$277,742

** FORT PEND COUNTY **
 EXPENSE BUDGET BY OBJECT

FUND 010 GENERAL FUND		AGENCY: 076 BUDGET OFFICE		FUNCC.			
ORG 0760 BUDGET OFFICE		ACTIVITY 1100 FINANCIAL ADMINISTRATION					
1998	BUDGET AS MODIFIED	TOTAL EST EXPENDITURE	ACCOUNT NAME	OBJECT	BUDGET REQUEST	*2000 RECOM ENDED	ADOPTED BUDGET
\$69,525	\$95,141	\$20,205	\$0 SALARIES AND LABOR	0200	\$97,594	\$102,473	\$101,714
\$0	\$1,000	\$0	\$0 TEMPORARY OR PART-TIME	0201	\$1,000	\$600	\$600
\$23	\$141	\$26	\$0 LONGEVITY	0250	\$259	\$259	\$259
\$6,689	\$7,317	\$1,494	\$0 SOCIAL SECURITY	0300	\$7,563	\$7,935	\$7,877
\$8,905	\$10,466	\$2,195	\$0 RETIREMENT	0400	\$10,765	\$11,300	\$11,217
\$9,100	\$8,400	\$8,400	\$0 INSURANCE(GROUP)	0500	\$8,400	\$9,000	\$9,000
\$2,908	\$1,942	\$1,942	\$0 WORKERS COMP/UNEMPLOYMENT	0600	\$3,066	\$2,044	\$2,029
\$3,901	\$4,200	\$170	\$0 TRAVEL REIMB/CONFERENCES	0701	\$4,300	\$4,200	\$4,200
\$80	\$550	\$317	\$0 PROPERTY AND EQUIPMENT	1010	\$200	\$200	\$200
\$1,397	\$2,866	\$450	\$0 CAPITAL ASSETS	1011	\$1,495	\$1,495	\$1,495
\$1,397	\$2,866	\$450	\$0 HARDWARE PURCHASES	1012	\$638	\$638	\$638
\$1,397	\$2,866	\$450	\$0 OFFICE SUPPLIES	1062	\$3,205	\$3,205	\$3,205
\$0	\$1,157	\$23	\$0 OTHER RENTALS	3020	\$708	\$708	\$708
\$19,985	\$16,483	\$1,569	\$0 SOFTWARE PURCHASES	3040	\$500	\$500	\$500
\$19,985	\$16,483	\$1,569	\$0 FEES & SERVICES	4010	\$10,385	\$10,385	\$10,385
\$165,292	\$171,878	\$39,260	\$0	TOTL	\$150,078	\$154,942	\$154,027
\$165,292	\$171,878	\$39,260	\$0	TOTAL FOR ACTIVITY 1100	\$150,078	\$154,942	\$154,027
\$165,292	\$171,878	\$39,260	\$0	TOTAL FOR ORGANIZATION 0760	\$150,078	\$154,942	\$154,027
\$165,292	\$171,878	\$39,260	\$0	TOTAL FOR AGENCY 076	\$150,078	\$154,942	\$154,027

EXPENSE BUDGET BY OBJECT

FUND	ORG	010 GENERAL FUND	077 CENTRAL MAIL ROOM	AGENCY	077 CENTRAL MAIL ROOM	ACTIVITY:	1000 GENERAL ADMINISTRATION	ACCOUNT NAME	OBJECT	BUDGET REQUEST	RECOM ENDED	ADOPTED BUDGET
1998		BUDGET	TOTAL EST									
		EXPENDITURE AS MODIFIED	EXPENDITURE	\$0	SALARIES AND LABOR	0200				\$43,214	\$45,374	\$45,564
\$41,548		\$42,601	\$9,272									
\$8,251		\$12,480	\$1,771	\$0	TEMPORARY OR PART-TIME	0201				\$12,480	\$12,480	\$12,480
\$431		\$543	\$116	\$0	LONGEVITY	0250				\$663	\$663	\$663
\$3,589		\$4,256	\$824	\$0	SOCIAL SECURITY	0300				\$4,312	\$4,477	\$4,491
\$4,174		\$4,746	\$1,020	\$0	RETIREMENT	0400				\$6,200	\$6,437	\$6,458
\$9,100		\$8,400	\$8,400	\$0	INSURANCE(GROUP)	0500				\$8,400	\$9,000	\$9,000
\$1,683		\$1,136	\$1,136	\$0	WORKERS COMP/UNEMPLOYMENT	0600				\$1,748	\$1,153	\$1,157
\$0		\$930	\$9	\$0	TRAVEL REIMB/CONFERENCES	0701				\$0	\$0	\$0
\$8,848		\$525	\$525	\$0	PROPERTY AND EQUIPMENT	1010				\$0	\$0	\$0
\$198,105		\$304,000	\$31,200	\$0	OFFICE SUPPLIES	1062				\$304,000	\$300,000	\$300,000
\$0		\$1,436	\$10	\$0	OTHER RENTALS	3020				\$550	\$550	\$550
\$0		\$1,436	\$10	\$0	INFORMATION TECHNOLOGY	LE3021				\$1,080	\$960	\$960
\$21,728		\$53,668	\$576	\$0	SOFTWARE PURCHASES	3040				\$568	\$568	\$568
\$21,728		\$53,668	\$576	\$0	FEES AND SERVICES	4010				\$49,390	\$49,390	\$49,390
\$319,185		\$489,825	\$55,445	\$0	TOTL					\$432,605	\$431,052	\$431,281
\$319,185		\$489,825	\$55,445	\$0	TOTAL FOR ACTIVITY	1000				\$432,605	\$431,052	\$431,281
\$319,185		\$489,825	\$55,445	\$0	TOTAL FOR ORGANIZATION	0770				\$432,605	\$431,052	\$431,281
\$319,185		\$489,825	\$55,445	\$0	TOTAL FOR AGENCY	077				\$432,605	\$431,052	\$431,281

FUND	010 GENERAL FUND	AGENCY: 078 RECORDS MANAGEMENT	ACCOUNT NAME	OBJECT	BUDGET REQUEST	*2000 RECOM ENDED	*ADPTED BUDGET
ORG	0780 RECORDS MANAGEMENT	ACTIVITY: 1000 GENERAL ADMINISTRATION			\$161,530	\$168,048	\$168,184
1998	BUDGET AS MODIFIED	EXP THRU 10/22/99	TOTAL EST EXPENDITURE				
	\$132,284	\$30,774	\$0 SALARIES AND LABOR	0200			
\$1,963	\$2,223	\$449	\$0 LONGEVITY	0250	\$2,508	\$2,508	\$2,508
\$10,027	\$11,086	\$2,569	\$0 SOCIAL SECURITY	0300	\$12,549	\$13,048	\$13,058
\$13,347	\$15,940	\$3,391	\$0 RETIREMENT	0400	\$18,045	\$18,761	\$18,776
\$22,750	\$21,000	\$21,000	\$0 INSURANCE(GROUP)	0500	\$25,200	\$27,000	\$27,000
\$4,222	\$2,958	\$2,958	\$0 WORKERS COMP/UNEMPLOYMENT	0600	\$5,078	\$3,360	\$3,363
\$0	\$0	\$0	\$0 TRAVEL ALLOWANCE	0700	\$0	\$0	\$0
\$826	\$1,200	\$104	\$0 TRAVEL REIMB/CONFERENCES	0701	\$500	\$500	\$500
\$11,643	\$7,800	\$0	\$0 PROPERTY AND EQUIPMENT	1010	\$0	\$0	\$0
\$11,643	\$7,800	\$0	\$0 CAPITAL ASSETS	1011	\$12,450	\$12,450	\$12,450
\$17,334	\$25,138	\$948	\$0 OFFICE SUPPLIES	1062	\$26,445	\$24,000	\$24,000
\$0	\$550	\$10	\$0 OTHER RENTALS	3020	\$550	\$550	\$550
\$3,915	\$6,482	\$95	\$0 INFORMATION TECHNOLOGY	LE3021	\$1,080	\$1,080	\$1,080
\$3,915	\$6,482	\$95	\$0 FEES AND SERVICES	4010	\$6,976	\$6,976	\$6,976
\$233,869	\$251,345	\$62,193	\$0	TOTL	\$272,911	\$278,281	\$278,445
\$233,869	\$251,345	\$62,193	\$0	TOTAL FOR ACTIVITY	\$272,911	\$278,281	\$278,445
\$233,869	\$251,345	\$62,193	\$0	TOTAL FOR ORGANIZATION	\$272,911	\$278,281	\$278,445
\$233,869	\$251,345	\$62,193	\$0	TOTAL FOR AGENCY	\$272,911	\$278,281	\$278,445

1998 BUDGET AS MODIFIED	1999 EXP THRU 10/22/99	TOTAL EST EXPENDITURE	ACCOUNT NAME	OBJECT	BUDGET REQUEST	*2000 RECOM ENDED	ADOPTED BUDGET
\$0	\$0	\$0	\$0 SALARIES AND LABOR	0200	\$99,839	\$99,839	\$99,839
\$0	\$0	\$0	\$0 TEMPORARY OR PART-TIME	0201	\$2,500	\$2,500	\$2,500
\$0	\$0	\$0	\$0 LONGEVITY	0250	\$84	\$84	\$84
\$0	\$0	\$0	\$0 SOCIAL SECURITY	0300	\$7,829	\$7,829	\$7,829
\$0	\$0	\$0	\$0 RETIREMENT	0400	\$10,982	\$10,982	\$10,982
\$0	\$0	\$0	\$0 INSURANCE (GROUP)	0500	\$12,600	\$13,500	\$13,500
\$0	\$0	\$0	\$0 WORKERS COMP./UNEMPLOYMENT	0600	\$3,173	\$1,967	\$1,967
\$0	\$0	\$0	\$0 TRAVEL ALLOWANCE	0700	\$3,856	\$3,840	\$3,840
\$0	\$0	\$0	\$0 TRAVEL REIMB./CONFERENCES	0701	\$5,000	\$3,500	\$3,500
\$0	\$0	\$0	\$0 PROPERTY & EQUIPMENT	1010	\$2,000	\$2,000	\$2,000
\$0	\$0	\$0	\$0 OFFICE SUPPLIES	1062	\$2,500	\$2,500	\$2,500
\$0	\$0	\$0	\$0 OTHER RENTALS	3020	\$1,185	\$1,185	\$1,185
\$0	\$0	\$0	\$0 I.T LEASES	3021	\$1,800	\$1,800	\$1,800
\$0	\$0	\$0	\$0 OTHER FEES AND SERVICES	4010	\$200,000	\$100,000	\$100,000
\$0	\$0	\$0	TOTAL		\$353,348	\$251,526	\$251,526
\$0	\$0	\$0	TOTAL FOR ACTIVITY 1200		\$353,348	\$251,526	\$251,526
\$0	\$0	\$0	TOTAL FOR ORGANIZATION 0800		\$353,348	\$251,526	\$251,526
\$0	\$0	\$0	TOTAL FOR AGENCY 080		\$353,348	\$251,526	\$251,526

EXPENSE BUDGET BY OBJECT

FUND 010 GENERAL FUND AGENCY: 081 400TH DISTRICT COURT
 ORG 0810 400TH DISTRICT COURT ACTIVITY: 1200 ADMINISTRATION OF JUSTICE FUNC.

1998 BUDGET AS MODIFIED	1999 EXP THRU 10/22/99	TOTAL EST EXPENDITURE	ACCOUNT NAME	OBJECT	BUDGET REQUEST	RECOM ENDED	ADOPTED BUDGET
\$0	\$0	\$0	\$0 SALARIES AND LABOR	0200	\$33,280	\$33,280	\$33,280
\$0	\$0	\$0	\$0 TEMPORARY OR PART-TIME	0201	\$800	\$800	\$800
\$0	\$0	\$0	\$0 LONGEVITY	0250	\$0	\$0	\$0
\$0	\$0	\$0	\$0 SOCIAL SECURITY	0300	\$2,607	\$2,607	\$2,607
\$0	\$0	\$0	\$0 RETIREMENT	0400	\$3,661	\$3,661	\$3,661
\$0	\$0	\$0	\$0 INSURANCE (GROUP)	0500	\$4,200	\$4,500	\$4,500
\$0	\$0	\$0	\$0 WORKERS COMP /UNEMPLOYMENT	0600	\$1,057	\$671	\$671
\$0	\$0	\$0	\$0 TRAVEL ALLOWANCE	0700	\$1,280	\$1,280	\$1,280
\$0	\$0	\$0	\$0 TRAVEL REIMB /CONFERENCES	0701	\$1,000	\$1,000	\$1,000
\$0	\$0	\$0	\$0 PROPERTY & EQUIPMENT	1010	\$5,000	\$5,000	\$5,000
\$0	\$0	\$0	\$0 OFFICE SUPPLIES	1062	\$1,000	\$1,000	\$1,000
\$0	\$0	\$0	\$0 OTHER RENTALS	3020	\$250	\$250	\$250
\$0	\$0	\$0	\$0 I.T LEASES	3021	\$600	\$600	\$600
\$0	\$0	\$0	\$0 OTHER FEES AND SERVICES	4010	\$66,666	\$33,333	\$33,333
\$0	\$0	\$0	\$0 GRAND JURY BAILIFF	4090	\$835	\$835	\$835
\$0	\$0	\$0	TOTAL		\$122,236	\$88,817	\$88,817
\$0	\$0	\$0	TOTAL FOR ACTIVITY	1200	\$122,236	\$88,817	\$88,817
\$0	\$0	\$0	TOTAL FOR ORGANIZATION	0810	\$122,236	\$88,817	\$88,817
\$0	\$0	\$0	TOTAL FOR AGENCY	081	\$122,236	\$88,817	\$88,817

Road & Bridge Revenue and Disbursements

REVENUE BUDGET BY REVENUE SOURCE

FUND 105 ROAD & BRIDGE
ORG

AGENCY: 999 REVENUE
ACTIVITY:

1998 REVENUE	BUDGET AS MODIFIED	1999 REV THRU 10/22/99	TOTAL EST REVENUE	ACCOUNT NAME	REVENUE SOURCE	REVENUE REQUEST	RECOM ENDED	ADOPTED REVENUE
\$67,914	\$0	\$12,662		REIMB FROM STATE	STAT	\$0	\$0	
\$80,149	\$70,000	\$54,336		PENALTY & INTEREST-PROP TX	OPPI	\$70,000	\$80,000	
\$1,811,562	\$1,800,000	\$1,820,578		AUTO REGISTRATION FEES	00AR	\$1,800,000	\$1,800,000	
\$9,050	\$0	\$0		AUCTION	00AU	\$0	\$0	
\$305,033	\$285,000	\$186,662		COUNTY CLERK	00CC	\$285,000	\$290,000	
\$146,523	\$120,000	\$94,121		DISTRICT CLERK	00DC	\$120,000	\$140,000	
\$214,678	\$170,000	\$141,590		PROPERTY TAXES - DELINQUENT	00GD	\$170,000	\$180,000	
\$7,610,329	\$7,481,308	\$7,514,126		PROPERTY TAXES - CURRENT	00GP	\$7,481,308		
\$8,656	\$0	\$0		INSURANCE CLAIMS	00IC	\$0	\$0	
\$495,899	\$400,000	\$300,593		INTEREST EARNED	00IE	\$400,000	\$425,000	
\$0	\$0	\$643		MISCELLANEOUS REVENUE	00MS	\$0	\$0	
\$41,476	\$0	\$34,060		REIMBURSEMENTS-MISCELLANEOUS	00RE	\$0	\$0	
\$2,233,212	\$2,200,000	\$1,023,340		TAX ASSESSOR/COLL FEES	00TA	\$2,200,000	\$2,200,000	
\$0	\$0	\$0		OPERATING TRANSFERS IN	00TR	\$0	\$0	
\$1,175	\$0	\$0		REFUNDS	000R	\$0	\$0	
\$13,025,656	\$12,526,308	\$11,182,711	\$0	TOTL	TOTL	\$12,526,308	\$5,115,000	\$0
\$13,025,656	\$12,526,308	\$11,182,711	\$0	TOTAL FOR ORGANIZATION		\$12,526,308	\$5,115,000	\$0
\$13,025,656	\$12,526,308	\$11,182,711	\$0	TOTAL FOR AGENCY	999	\$12,526,308	\$5,115,000	\$0
\$13,025,656	\$12,526,308	\$11,182,711	\$0	TOTAL FOR FUND	105	\$12,526,308	\$5,115,000	\$0

EXPENSE BUDGET BY OBJECT

FUND	105 ROAD & BRIDGE	AGENCY	075 ROAD & BRIDGE	ACTIVITY	1300 ROAD AND BRIDGE MAINTENANCE	FUNC.			
ORG	0750 ROAD & BRIDGE								
1998	BUDGET	1999	EXP THRU	TOTAL EST	ACCOUNT NAME	OBJECT	BUDGET	RECOM	ADOPTED
EXPENDITURE	AS MODIFIED	10/22/99	EXPENDITURE				REQUEST	ENDED	BUDGET
\$3,681,389	\$4,072,954	\$823,650	\$20,293	\$20,293	\$0 SALARIES AND LABOR	0200	\$4,083,216	\$4,189,335	\$4,190,220
\$171,666	\$225,000	\$20,293	\$20,293	\$20,293	\$0 TEMPORARY OR PART-TIME	0201	\$225,000	\$200,000	\$200,000
\$299,804	\$300,000	\$31,714	\$31,714	\$31,714	\$0 OVERTIME	0202	\$300,000	\$300,000	\$300,000
\$67,471	\$74,657	\$14,486	\$14,486	\$14,486	\$0 LONGEVITY	0250	\$79,310	\$79,340	\$79,340
\$312,061	\$357,476	\$66,667	\$66,667	\$66,667	\$0 SOCIAL SECURITY	0300	\$358,596	\$364,804	\$364,871
\$404,942	\$489,268	\$94,594	\$94,594	\$94,594	\$0 RETIREMENT	0400	\$490,878	\$502,554	\$502,652
\$618,800	\$575,400	\$575,400	\$575,400	\$575,400	\$0 INSURANCE(GROUP)	0500	\$583,800	\$607,500	\$607,500
\$137,001	\$95,374	\$95,374	\$95,374	\$95,374	\$0 WORKERS COMP/UNEMPLOYMENT	0600	\$145,314	\$93,943	\$93,960
\$7,984	\$7,500	\$1,137	\$1,137	\$1,137	\$0 TRAVEL REIMB/CONFERENCES	0701	\$8,500	\$8,500	\$8,500
\$387,026	\$614,017	\$264,811	\$264,811	\$264,811	\$0 PROPERTY AND EQUIPMENT	1010	\$10,000	\$10,000	\$10,000
\$13,857	\$20,500	\$3,096	\$3,096	\$3,096	\$0 CAPITAL ASSETS	1011	\$830,036	\$524,836	\$524,836
\$13,857	\$20,500	\$3,096	\$3,096	\$3,096	\$0 OFFICE SUPPLIES	1062	\$20,000	\$18,000	\$18,000
\$7,336	\$399,310	\$38,589	\$38,589	\$38,589	\$0 PERMANENT IMPROVEMENT	1070	\$195,000	\$337,220	\$337,220
\$102,525	\$165,250	\$17,752	\$17,752	\$17,752	\$0 UTILITIES	2000	\$150,000	\$150,000	\$150,000
\$61,203	\$129,390	\$7,376	\$7,376	\$7,376	\$0 OTHER RENTALS	3020	\$143,800	\$140,800	\$140,800
\$395,443	\$551,293	\$82,234	\$82,234	\$82,234	\$0 INFORMATION TECHNOLOGY	LE3021	\$4,800	\$4,800	\$4,800
\$395,443	\$551,293	\$82,234	\$82,234	\$82,234	\$0 OTHER FEES AND SERVICES	4010	\$440,000	\$440,000	\$440,000
\$57,572	\$65,129	\$11,012	\$11,012	\$11,012	\$0 UNIFORMS	4011	\$70,000	\$65,000	\$65,000
\$0	\$0	\$0	\$0	\$0	\$0 MERIT POOL	4070	\$0	\$0	\$0
\$3,594,247	\$4,215,002	\$512,137	\$512,137	\$512,137	\$0 ROAD MATERIALS	5031	\$4,500,000	\$4,200,000	\$4,200,000
\$0	\$133,266	\$0	\$0	\$0	\$0 AUTOMOBILES	6025	\$534,000	\$192,000	\$192,000
\$0	\$0	\$0	\$0	\$0	\$0 CLOTHING	7000	\$0	\$0	\$0
\$100,762	\$58,193	\$2,730	\$2,730	\$2,730	\$0 LUMBER AND HARDWARE	7003	\$160,000	\$160,000	\$160,000
\$166,157	\$170,000	\$37,363	\$37,363	\$37,363	\$0 ROAD SIGNS	7004	\$200,000	\$200,000	\$200,000
\$236,290	\$320,030	\$32,083	\$32,083	\$32,083	\$0 GAS AND OIL	7005	\$300,000	\$270,000	\$270,000

Drainage District Maintenance Fund Revenue and Disbursements

FUND. 115 DRAINAGE DISTRICT AGENCY. 999 REVENUE
 ORG. ACTIVITY:

1998 REVENUE	BUDGET AS MODIFIED	1999 REV THRU 10/22/99	TOTAL EST REVENUE	ACCOUNT NAME	REVENUE SOURCE	REVENUE REQUEST	RECOM ENDED	ADOPTED REVENUE
\$49,483	\$50,000	\$35,523		PENALTY & INTEREST-PROP TX	OPPI	\$50,000	\$50,000	
\$1,976	\$0	\$0		AUCTION	00AU	\$0		
\$126,165	\$120,000	\$86,215		PROPERTY TAXES - DELINQUENT	00GD	\$120,000	\$120,000	
\$4,809,524	\$4,947,166	\$4,916,370		PROPERTY TAXES - CURRENT	00GP	\$4,947,166		
\$0	\$0	\$0		INSURANCE CLAIMS	00IC	\$0	\$0	
\$298,609	\$260,000	\$201,461		INTEREST EARNED	00IE	\$260,000	\$280,000	
\$300	\$0	\$376		MISCELLANEOUS REVENUE	00MS	\$0	\$0	
\$14,769	\$0	\$26,627		REIMBURSEMENTS-MISCELLANEOUS	00RE	\$0	\$0	
\$0	\$0	\$0		OPERATING TRANSFERS IN	00TR	\$0	\$0	
\$245	\$0	\$0		REFUNDS	000R	\$0	\$0	
\$5,301,071	\$5,377,166	\$5,266,572	\$0	TOTL		\$5,377,166	\$450,000	\$0
\$5,301,071	\$5,377,166	\$5,266,572	\$0	TOTAL FOR ORGANIZATION		\$5,377,166	\$450,000	\$0
\$5,301,071	\$5,377,166	\$5,266,572	\$0	TOTAL FOR AGENCY	999	\$5,377,166	\$450,000	\$0
\$5,301,071	\$5,377,166	\$5,266,572	\$0	TOTAL FOR FUND	115	\$5,377,166	\$450,000	\$0

EXPENSE BUDGET BY OBJECT

FUND	115 DRAINAGE DISTRICT	AGENCY: 051 DRAINAGE DISTRICT	FUNC	BUDGET REQUEST	RECOM ENDED	ADOPTED BUDGET
ORG	0510 DRAINAGE DISTRICT-COUNTY	ACTIVITY: 1800 FLOOD CONTROL PROJECTS		\$2,170,269	\$2,278,779	\$2,278,840
1998	BUDGET AS MODIFIED	TOTAL EST EXPENDITURE	ACCOUNT NAME	OBJECT		
	\$2,003,691	\$2,183,727	\$0 SALARIES AND LABOR	0200	\$2,278,779	\$2,278,840
	\$0	\$0	\$0 TEMPORARY OR PART-TIME	0201	\$10,000	\$10,000
	\$157,718	\$14,804	\$0 OVERTIME	0202	\$155,000	\$155,000
	\$46,699	\$10,411	\$0 LONGEVITY	0250	\$54,746	\$54,746
	\$163,258	\$35,491	\$0 SOCIAL SECURITY	0300	\$191,137	\$191,142
	\$220,613	\$51,875	\$0 RETIREMENT	0400	\$273,738	\$273,744
	\$336,700	\$310,800	\$0 INSURANCE(GROUP)	0500	\$333,000	\$333,000
	\$68,250	\$67,200	\$0 INSURANCE(GROUP/RET)	0501	\$49,221	\$67,200
	\$70,537	\$48,706	\$0 WORKERS COMP/UNEEMPLOYMENT	0600	\$48,876	\$49,222
	\$3,749	\$353	\$0 TRAVEL REIMB/CONFERENCES	0701	\$5,500	\$5,500
	\$534,858	\$54,738	\$0 PROPERTY AND EQUIPMENT	1010	\$20,000	\$17,000
	\$534,858	\$54,738	\$0 CAPITAL ASSETS	1011	\$350,000	\$298,100
	\$5,309	\$399	\$0 OFFICE SUPPLIES	1062	\$5,500	\$5,500
	\$30,534	\$150	\$0 PERMANENT IMPROVEMENT	1070	\$60,000	\$60,000
	\$26,440	\$3,511	\$0 UTILITIES	2000	\$26,700	\$26,700
	\$4,813	\$392	\$0 ENGINEERING SUPPLIES	2001	\$3,500	\$3,500
	\$9,446	\$1,581	\$0 OTHER RENTALS	3020	\$14,500	\$13,000
	\$9,446	\$1,581	\$0 INFORMATION TECHNOLOGY LE	3021	\$2,400	\$2,400
	\$9,446	\$1,581	\$0 SOFTWARE PURCHASES	3040	\$1,100	\$1,100
	\$53,623	\$11,668	\$0 OTHER FEES AND SERVICES	4010	\$100,000	\$100,000
	\$15,305	\$2,376	\$0 UNIFORMS	4011	\$23,000	\$23,000
	\$0	\$0	\$0 CONTINGENCY	4040	\$60,000	\$50,000
	\$0	\$0	\$0 MERIT POOL	4070	\$0	\$0
	\$0	\$35,352	\$0 AUTOMOBILES	6025	\$241,000	\$191,500
	\$185,322	\$52,183	\$0 LUMBER AND HARDWARE	7003	\$185,000	\$185,000

1998 BUDGET AS MODIFIED	1999 EXP THRU 10/22/99	TOTAL EST EXPENDITURE	ACCOUNT NAME	OBJECT	BUDGET REQUEST	RECOM ENDED	ADOPTED BUDGET
\$137,240	\$8,064	\$0	\$0 GAS AND OIL	7005	\$160,000	\$160,000	\$160,000
\$21,872	\$3,236	\$0	\$0 TIRES AND TUBES	7006	\$20,000	\$20,000	\$20,000
\$422,931	\$82,169	\$0	\$0 REPAIRS & PARTS/SHOP SUPP7007	7007	\$525,000	\$525,000	\$525,000
\$1,460	\$33	\$0	\$0 REPAIRS-BUILDINGS	7012	\$10,000	\$5,000	\$5,000
\$264,961	\$39,972	\$0	\$0 HERBICIDE/INSECTICIDE	7013	\$275,000	\$275,000	\$275,000
\$0	\$0	\$0	\$0 CAPITAL OUTLAY	7015	\$0	\$0	\$0
\$11,539	\$2,500	\$0	\$0 DRAINAGE DISTRICT BOARD	9010	\$12,000	\$12,000	\$12,000
\$19,978	\$3,582	\$0	\$0 SEEDING & EROSION CONTROL9021	9021	\$20,000	\$20,000	\$20,000
\$128	\$2	\$0	\$0 PROPERTY SETTLEMENT	9036	\$1,000	\$1,000	\$1,000
\$5,370,724	\$1,349,098	\$0	TOTAL	TOTL	\$5,392,047	\$5,394,797	\$5,413,194
\$5,370,724	\$1,349,098	\$0	TOTAL FOR ACTIVITY	1800	\$5,392,047	\$5,394,797	\$5,413,194
\$5,370,724	\$1,349,098	\$0	TOTAL FOR ORGANIZATION	0510	\$5,392,047	\$5,394,797	\$5,413,194
\$5,370,724	\$1,349,098	\$0	TOTAL FOR AGENCY	051	\$5,392,047	\$5,394,797	\$5,413,194
\$5,370,724	\$1,349,098	\$0	TOTAL FOR FUND	115	\$5,392,047	\$5,394,797	\$5,413,194

County Law Library

REVENUE BUDGET BY REVENUE SOURCE

FUND. 125 COUNTY LAW LIBRARY AGENCY 999 REVENUE
 ORG. ACTIVITY

1998 REVENUE	BUDGET AS MODIFIED	1999 REV THRU 10/22/99	TOTAL EST REVENUE	ACCOUNT NAME	REVENUE SOURCE	REVENUE REQUEST	*2000 RECOM ENDED	ADOPTED REVENUE
\$91,240	\$85,000	\$55,640		COURT COST	00CX	\$85,000	\$85,000	
\$6,695	\$6,500	\$3,232		INTEREST EARNED	00IE	\$6,500	\$6,500	
\$8,034	\$7,400	\$5,597		LAW LIBRARY	00LL	\$7,400	\$8,000	
\$0	\$0	\$0		MISCELLANEOUS REVENUE	00MS	\$0	\$0	
\$105,969	\$98,900	\$64,469	\$0	TOTAL	TOTL	\$98,900	\$99,500	\$0
\$105,969	\$98,900	\$64,469	\$0	TOTAL FOR ORGANIZATION		\$98,900	\$99,500	\$0
\$105,969	\$98,900	\$64,469	\$0	TOTAL FOR AGENCY	999	\$98,900	\$99,500	\$0
\$105,969	\$98,900	\$64,469	\$0	TOTAL FOR FUND	125	\$98,900	\$99,500	\$0

** FORT BEND COUNTY **
 EXPENSE BUDGET BY OBJECT

FUND. 125 COUNTY LAW LIBRARY		AGENCY: 616 COUNTY LAW LIBRARY		FUNC.			
ORG 6160 COUNTY LAW LIBRARY		ACTIVITY: 1200 ADMINISTRATION OF JUSTICE					
BUDGET AS MODIFIED	EXP THRU 10/22/99	TOTAL EST EXPENDITURE	ACCOUNT NAME	OBJECT	BUDGET REQUEST	*2000 RECOM ENDED	ADOPTED BUDGET
\$30,764	\$6,955	\$0	\$0 SALARIES AND LABOR	0200	\$32,417	\$34,038	\$34,038
\$538	\$196	\$0	\$0 TEMPORARY OR PART-TIME	0201	\$1,000	\$1,000	\$1,000
\$755	\$168	\$0	\$0 LONGEVITY	0250	\$864	\$864	\$864
\$2,581	\$546	\$0	\$0 SOCIAL SECURITY	0300	\$2,623	\$2,680	\$2,746
\$3,133	\$774	\$0	\$0 RETIREMENT	0400	\$3,771	\$3,744	\$3,839
\$4,550	\$4,200	\$0	\$0 INSURANCE(GROUP)	0500	\$4,200	\$4,500	\$4,500
\$980	\$691	\$0	\$0 WORKERS COMP/UNEMPLOYMENT0600	0600	\$1,063	\$690	\$707
\$1,365	\$0	\$0	\$0 TRAVEL REIMB/CONFERENCES	0701	\$1,400	\$1,400	\$1,400
\$3,345	\$0	\$0	\$0 PROPERTY AND EQUIPMENT	1010	\$500	\$500	\$500
\$3,345	\$0	\$0	\$0 HARDWARE PURCHASES	1012	\$3,000	\$3,000	\$3,000
\$254	\$0	\$0	\$0 REPAIRS TO EQUIPMENT	1020	\$700	\$300	\$300
\$1,796	\$598	\$0	\$0 OFFICE SUPPLIES	1062	\$2,100	\$2,100	\$2,100
\$1,437	\$443	\$0	\$0 OTHER RENTALS	3020	\$1,500	\$1,500	\$1,500
\$57,547	\$19,259	\$0	\$0 BOOKS AND MAGAZINES	3050	\$60,000	\$60,000	\$60,000
\$1,705	\$248	\$0	\$0 OTHER FEES AND SERVICES	4010	\$2,300	\$2,300	\$2,300
\$0	\$0	\$0	\$0 REPAIRS-BUILDINGS	7012	\$500	\$500	\$500
\$113,895	\$34,078	\$0	TOTL	TOTL	\$117,938	\$119,116	\$119,294
\$113,895	\$34,078	\$0	TOTAL FOR ACTIVITY	1200	\$117,938	\$119,116	\$119,294
\$113,895	\$34,078	\$0	TOTAL FOR ORGANIZATION	6160	\$117,938	\$119,116	\$119,294
\$113,895	\$34,078	\$0	TOTAL FOR AGENCY	616	\$117,938	\$119,116	\$119,294
\$113,895	\$34,078	\$0	TOTAL FOR FUND	125	\$117,938	\$119,116	\$119,294

Gus George Law Academy Revenue and Disbursements

FUND. 126 GUS GEORGE LAW ACADEMY AGENCY: 999 REVENUE
ORG. ACTIVITY:

1998 REVENUE	BUDGET AS MODIFIED	1999 REV THRU 10/22/99	TOTAL EST REVENUE	ACCOUNT NAME	REVENUE SOURCE	REVENUE REQUEST	*2000 RECOM ENDED	ADOPTED REVENUE
\$27,840	\$15,000	\$20,740		REIMB FROM STATE	STAT	\$15,000	\$30,000	
\$0	\$0	\$0		DONATIONS	0000	\$0	\$0	
\$4,294	\$4,000	\$2,960		INTEREST EARNED	001E	\$4,000	\$4,000	
\$26,699	\$25,000	\$25,340		LAW ENF ACADEMY - ENROLLMENT	001E	\$25,000	\$28,000	
\$8,221	\$5,000	\$16,246		MISCELLANEOUS REVENUE	00MS	\$5,000	\$7,000	
\$0	\$0	\$0		REIMBURSEMENTS-MISCELLANEOUS	00RE	\$0	\$0	
\$0	\$0	\$77		REFUNDS	00OR	\$0	\$0	
\$67,054	\$49,000	\$65,363	\$0	TOTAL	TOTL	\$49,000	\$69,000	\$0
\$67,054	\$49,000	\$65,363	\$0	TOTAL FOR ORGANIZATION		\$49,000	\$69,000	\$0
\$67,054	\$49,000	\$65,363	\$0	TOTAL FOR AGENCY	999	\$49,000	\$69,000	\$0
\$67,054	\$49,000	\$65,363	\$0	TOTAL FOR FUND	126	\$49,000	\$69,000	\$0

EXPENSE BUDGET BY OBJECT

FUND. 126 GUS GEORGE LAW ACADEMY AGENCY. 027 SHERIFF'S DEPARTMENT
 ORG 0272 GUS GEORGE LAW ENF ACADEMY ACTIVITY: 1600 PUBLIC SAFETY

1998 BUDGET AS MODIFIED	1999 EXP THRU 10/22/99	TOTAL EST EXPENDITURE	ACCOUNT NAME	OBJECT	BUDGET REQUEST	*2000 RECOM ENDED	ADOPTED BUDGET
\$24,570	\$638	\$0	\$0 TRAVEL REIMB /CONFERENCES0701	1010	\$0	\$2,000	\$2,000
\$3,092	\$758	\$0	\$0 PROPERTY AND EQUIPMENT	1010	\$8,655	\$8,655	\$8,655
\$9,923	\$2,005	\$0	\$0 CAPITAL ASSETS	1011	\$4,250	\$4,250	\$4,250
\$0	\$0	\$0	\$0 I T. HARDWARE PURCHASES	1012	\$2,500	\$2,500	\$2,500
\$0	\$0	\$0	\$0 REPAIRS TO EQUIPMENT	1020	\$3,000	\$1,500	\$1,500
\$0	\$0	\$0	\$0 OFFICE SUPPLIES	1062	\$7,500	\$7,500	\$7,500
\$0	\$0	\$0	\$0 UTILITIES	2000	\$14,466	\$14,466	\$14,466
\$0	\$0	\$0	\$0 JANITORIAL AND PEST CONTR	2060	\$100	\$100	\$100
\$0	\$0	\$0	\$0 SOFTWARE PURCHASES	3040	\$500	\$500	\$500
\$0	\$0	\$0	\$0 BOOKS AND MAGAZINES	3050	\$500	\$200	\$200
\$24,862	\$4,318	\$0	\$0 OTHER FEES AND SERVICES	4010	\$30,345	\$29,300	\$29,300
\$2,333	\$2,767	\$0	\$0 OFFICERS TRAINING SUPPLIE	4013	\$10,000	\$10,000	\$10,000
\$1,532	\$0	\$0	\$0 REPAIRS-BUILDINGS	7012	\$5,000	\$4,000	\$4,000
\$66,645	\$10,511	\$0	TOTL	TOTL	\$86,816	\$84,971	\$84,971
\$66,645	\$10,511	\$0	TOTAL FOR ACTIVITY	1600	\$86,816	\$84,971	\$84,971

EXPENSE BUDGET BY OBJECT

FUND.	126 GUS GEORGE LAW ACADEMY	AGENCY.	027 SHERIFF'S DEPARTMENT	FUNC	BUDGET REQUEST	*2000 RECOM ENDED	ADOPTED BUDGET
ORG	0272 GUS GEORGE LAW ENF ACADEMY	ACTIVITY.	4000 TRANSFER OUT		\$0	\$0	\$0
1998	BUDGET AS MODIFIED	TOTAL EST EXPENDITURE	ACCOUNT NAME	OBJECT			
	\$0	\$0	\$0 OPERATING TRANSFER OUT	9200			
	\$0	\$0		TOTAL	\$0	\$0	\$0
	\$0	\$0	TOTAL FOR ACTIVITY	4000	\$0	\$0	\$0
\$66,645	\$80,515	\$10,511	TOTAL FOR ORGANIZATION	0272	\$86,816	\$84,971	\$84,971
\$66,645	\$80,515	\$10,511	TOTAL FOR AGENCY	027	\$86,816	\$84,971	\$84,971
\$66,645	\$80,515	\$10,511	TOTAL FOR FUND	126	\$86,816	\$84,971	\$84,971

Records Management – County Clerk Revenues and Disbursements

RUN: DATE . 22 OCT 99
 RUN: 13 1
 FUND. 144 RECORDS MANAGEMENT - CC
 ORG AGENCY 999 REVENUE
 ACTIVITY:

1998 REVENUE	BUDGET AS MODIFIED	1999 REV THRU 10/22/99	TOTAL EST REVENUE	ACCOUNT NAME	REVENUE SOURCE	REVENUE REQUEST	RECOM ENDED	ADOPTED REVENUE
\$521,475	\$415,000	\$286,633		COURT COST	00CX	\$415,000	\$460,000	
\$19,787	\$13,000	\$10,144		INTEREST EARNED	00IE	\$13,000	\$18,000	
\$541,262	\$428,000	\$296,777	\$0	TOTAL	TOTL	\$428,000	\$478,000	\$0
\$541,262	\$428,000	\$296,777	\$0	TOTAL FOR ORGANIZATION		\$428,000	\$478,000	\$0
\$541,262	\$428,000	\$296,777	\$0	TOTAL FOR AGENCY	999	\$428,000	\$478,000	\$0
\$541,262	\$428,000	\$296,777	\$0	TOTAL FOR FUND	144	\$428,000	\$478,000	\$0

FUND 144 RECORDS MANAGEMENT - CC AGENCY: 001 COUNTY JUDGE
 ORG 0011 RECORDS MANAGEMENT ACTIVITY: 1000 GENERAL ADMINISTRATION

1998 BUDGET AS MODIFIED	EXP THRU 10/22/99	1999 * * * * *	TOTAL EST EXPENDITURE	ACCOUNT NAME	OBJECT	BUDGET REQUEST	*2000 RECOM ENDED	ADOPTED BUDGET
\$0	\$10,257	\$0	\$10,257	\$0 TEMP /PART-TIME	0201	\$52,000	\$53,928	\$53,928
\$0	\$785	\$0	\$785	\$0 SOCIAL SECURITY	0300	\$3,978	\$4,126	\$4,126
\$0	\$0	\$0	\$0	\$0 RETIREMENT	0400	\$5,720	\$4,758	\$4,758
\$0	\$1,062	\$0	\$1,062	\$0 WORKERC COMP/UNEMPL	0600	\$1,062	\$1,062	\$1,062
\$159,286	\$5,813	\$0	\$5,813	\$0 PROPERTY AND EQUIPMENT	1010	\$78,991	\$2,950	\$2,950
\$0	\$0	\$0	\$0	\$0 CAPITAL ASSETS	1011	\$0	\$80,500	\$80,500
\$0	\$0	\$0	\$0	\$0 I. I. HARDWARE PURCHASES	1012	\$0	\$15,840	\$15,840
\$0	\$0	\$0	\$0	\$0 OFFICE SUPPLIES	1062	\$0	\$0	\$0
\$0	\$0	\$0	\$0	\$0 PERMANENT IMPROVEMENT	1070	\$40,000	\$0	\$0
\$0	\$0	\$0	\$0	\$0 I. T. LEASES	3021	\$0	\$6,515	\$6,515
\$152,538	\$163	\$0	\$163	\$0 FEES AND SERVICES	4010	\$232,116	\$277,642	\$277,642
\$0	\$0	\$0	\$0	\$0 CONTINGENCY	4040	\$20,550	\$50,000	\$50,000
\$311,824	\$18,080	\$0	\$18,080	\$0	TOTL	\$434,417	\$497,321	\$497,321
\$311,824	\$18,080	\$0	\$18,080	\$0	TOTAL FOR ACTIVITY 1000	\$434,417	\$497,321	\$497,321

Fort Bend County Records Management Fund Revenue and Disbursements

** REVENUE BUDGET **
 REVENUE BUDGET BY REVENUE SOURCE

FUND. 147 FBC RECORDS MANAGEMENT
 ORG

AGENCY: 999 REVENUE
 ACTIVITY.

1998 REVENUE	BUDGET AS MODIFIED	1999 REV THRU 10/22/99	TOTAL EST REVENUE	ACCOUNT NAME	REVENUE SOURCE	REVENUE REQUEST	*2000 RECOM ENDED	ADOPTED REVENUE
\$74,185	\$38,000	\$81,511		COURT COST	00CX	\$38,000	\$50,000	\$0
\$6,368	\$3,400	\$3,601		INTEREST EARNED	00IE	\$3,400	\$5,000	\$0
\$80,553	\$41,400	\$85,112	\$0		TOTL	\$41,400	\$55,000	\$0
\$80,553	\$41,400	\$85,112	\$0	TOTAL FOR ORGANIZATION		\$41,400	\$55,000	\$0
\$80,553	\$41,400	\$85,112	\$0	TOTAL FOR AGENCY	999	\$41,400	\$55,000	\$0
\$80,553	\$41,400	\$85,112	\$0	TOTAL FOR FUND	147	\$41,400	\$55,000	\$0

FUND. 147 FBC RECORDS MANAGEMENT		AGENCY. 001 COUNTY JUDGE		FUNCT.			
ORG. 0012 RECORDS MANAGEMENT - FBC		ACTIVITY. 1000 GENERAL ADMINISTRATION					
1998	1999	TOTAL EST	ACCOUNT NAME	OBJECT	BUDGET REQUEST	RECOM ENDED	ADOPTED BUDGET
EXPENDITURE AS MODIFIED	EXP THRU 10/22/99	EXPENDITURE		0200	\$0	\$21,740	\$21,740
\$0	\$0	\$0	\$0 SALARIES AND LABOR	0201	\$0	\$0	\$0
\$0	\$12,837	\$0	\$0 TEMPORARY OR PART-TIME	0201	\$21,740	\$0	\$0
\$0	\$982	\$0	\$0 SOCIAL SECURITY	0300	\$982	\$1,663	\$1,663
\$0	\$1,412	\$0	\$0 RETIREMENT	0400	\$1,412	\$2,391	\$2,391
\$0	\$0	\$0	\$0 INSURANCE (GROUP)	0500	\$0	\$4,500	\$4,500
\$0	\$262	\$262	\$0 WORKERS COMP/UNEMPLO	0600	\$262	\$446	\$446
\$618	\$14,112	\$770	\$0 PROPERTY AND EQUIPMENT	1010	\$14,112	\$0	\$0
\$10,872	\$54,378	\$1,259	\$0 FEES AND SERVICES	4010	\$54,378	\$24,527	\$24,527
\$11,490	\$83,983	\$2,291	\$0	TOTL	\$92,886	\$55,267	\$55,267
\$11,490	\$83,983	\$2,291	\$0	TOTAL FOR ACTIVITY 1000	\$92,886	\$55,267	\$55,267

Courthouse Security Fund Revenue and Disbursements

FUND. 149	COURTHOUSE SECURITY	BUDGET AS MODIFIED	1999 REV THRU 10/22/99	TOTAL EST REVENUE	ACCOUNT NAME	REVENUE SOURCE	REVENUE REQUEST	*2000 RECOM ENDED	ADOPTED REVENUE
1998		\$183,493	\$110,000	\$124,234	COURT COST	00CX	\$110,000	\$120,000	
		\$29,959	\$17,000	\$19,616	INTEREST EARNED	00IE	\$17,000	\$25,000	
		\$213,452	\$127,000	\$143,850		TOTL	\$127,000	\$145,000	\$0
		\$213,452	\$127,000	\$143,850	TOTAL FOR ORGANIZATION		\$127,000	\$145,000	\$0
		\$213,452	\$127,000	\$143,850	TOTAL FOR AGENCY	999	\$127,000	\$145,000	\$0
		\$213,452	\$127,000	\$143,850	TOTAL FOR FUND	149	\$127,000	\$145,000	\$0

** FORT BEND COUNTY **
EXPENSE BUDGET BY OBJECT

RUN DATE, 22 OCT 99
RUN 13

FUND: 149 COURTHOUSE SECURITY
ORG: 0013 COURTHOUSE SECURITY

AGENCY: 001 COUNTY JUDGE
ACTIVITY: 1600 PUBLIC SAFETY

1998 EXPENDITURE \$656	BUDGET AS MODIFIED \$0	1999 EXP THRU 10/22/99 \$0	TOTAL EST EXPENDITURE \$0	ACCOUNT NAME	OBJECT	BUDGET REQUEST \$0	*2000 RECOM ENDED \$0	ADOPTED BUDGET \$0	FUNC
\$4,819	\$33,529	\$9,825	\$0	PROPERTY AND EQUIPMENT	1010	\$33,529	\$50,000	\$50,000	
\$0	\$60,000	\$0	\$0	PERMANENT IMPROVEMENT	1070	\$60,000	\$0	\$0	
\$44,349	\$40,000	\$150	\$0	OTHER FEES AND SERVICES	4010	\$40,000	\$75,000	\$75,000	
\$49,824	\$133,529	\$9,975	\$0	TOTL		\$133,529	\$125,000	\$125,000	
\$49,824	\$133,529	\$9,975	\$0	TOTAL FOR ACTIVITY	1600	\$133,529	\$125,000	\$125,000	
\$49,824	\$133,529	\$9,975	\$0	TOTAL FOR ORGANIZATION	0013	\$133,529	\$125,000	\$125,000	
\$49,824	\$133,529	\$9,975	\$0	TOTAL FOR AGENCY	001	\$133,529	\$125,000	\$125,000	
\$49,824	\$133,529	\$9,975	\$0	TOTAL FOR FUND	149	\$133,529	\$125,000	\$125,000	

Child Support Title IV-D Reimbursement Expenditures

** REVENUE BUDGET **
REVENUE BUDGET BY REVENUE SOURCE

RUN DATE 22 OCT 99
MON 1 - 13 - - -

FUND. 860 CHILD SUPPORT TITLE IV-D REIMB AGENCY: 999 REVENUE
ORG. ACTIVITY.

1998 REVENUE	BUDGET AS MODIFIED	** ** ** ** 1999 ** ** REV THRU 10/22/99	** ** ** ** TOTAL EST REVENUE	ACCOUNT NAME	REVENUE SOURCE	REVENUE REQUEST	**2000 * RECOM ENDED	ADOPTED REVENUE
\$11,029	\$0	\$36,325	\$0	FEDERAL PAYMENTS	OFED	\$0	\$0	\$0
\$30	\$0	\$583	\$0	INTEREST EARNED	00IE	\$0	\$0	\$0
\$11,059	\$0	\$36,908	\$0	TOTL	TOTL	\$0	\$0	\$0
\$11,059	\$0	\$36,908	\$0	TOTAL FOR ORGANIZATION		\$0	\$0	\$0
\$11,059	\$0	\$36,908	\$0	TOTAL FOR AGENCY	999	\$0	\$0	\$0
\$11,059	\$0	\$36,908	\$0	TOTAL FOR FUND	860	\$0	\$0	\$0

** FORT BEND COUNTY **
EXPENSE BUDGET BY OBJECT

FUND: 860 CHILD SUPPORT TITLE IV-D REIMB AGENCY: 014 CHILD SUPPORT
 ORG. 0141 CHILD SUPPORT TITLE IV-D REIMB ACTIVITY: 1200 ADMINISTRATION OF JUSTICE FUNC.

1998	BUDGET AS MODIFIED	EXP THRU 10/22/99	TOTAL EST EXPENDITURE	ACCOUNT NAME	OBJECT	BUDGET REQUEST	RECOM ENDED	ADOPTE BUDGET
\$0	\$3,700	\$2,366	\$0	TEMPORARY OR PART-TIME	0201	\$3,700	\$0	\$0
\$0	\$289	\$181	\$0	SOCIAL SECURITY	0300	\$289	\$0	\$0
\$0	\$6,300	\$0	\$0	PROPERTY AND EQUIPMENT	1010	\$6,300	\$7,000	\$7,000
\$0	\$0	\$0	\$0	I.T. LEASES	3021	\$2,880	\$2,880	\$2,880
\$0	\$0	\$0	\$0	FEES AND SERVICES	4010	\$1,250	\$1,250	\$1,250
\$0	\$10,289	\$2,547	\$0	TOTAL		\$14,419	\$11,130	\$11,130
\$0	\$10,289	\$2,547	\$0	TOTAL FOR ACTIVITY	1200	\$14,419	\$11,130	\$11,130
\$0	\$10,289	\$2,547	\$0	TOTAL FOR ORGANIZATION	0141	\$14,419	\$11,130	\$11,130
\$0	\$10,289	\$2,547	\$0	TOTAL FOR AGENCY	014	\$14,419	\$11,130	\$11,130
\$0	\$10,289	\$2,547	\$0	TOTAL FOR FUND	860	\$14,419	\$11,130	\$11,130

Debt Service Funds

REVENUE BUDGET BY REVENUE SOURCE

FUND. 306 FBFCMSC DEBT SERVICE-COUNTY
ORG

AGENCY. 999 REVENUE
ACTIVITY:

1998 REVENUE	BUDGET AS MODIFIED	1999 REV THRU 10/22/99	TOTAL EST REVENUE	ACCOUNT NAME	REVENUE SOURCE	REVENUE REQUEST	*2000 RECOM ENDED	ADOPTED REVENUE
\$18,784	\$11,000	\$8,847		PENALTY & INTEREST-PROP TX	OPPI	\$11,000	\$15,000	
\$49,745	\$30,000	\$16,453		PROPERTY TAXES - DELINQUENT	00GD	\$30,000	\$35,000	
\$2,086,321	\$1,743,757	\$1,751,498		PROPERTY TAXES - CURRENT	00GP	\$1,743,757		
\$73,807	\$50,000	\$36,326		INTEREST EARNED	00IE	\$50,000	\$60,000	
\$2,228,657	\$1,834,757	\$1,813,124	\$0		TOTL	\$1,834,757	\$110,000	\$0
\$2,228,657	\$1,834,757	\$1,813,124	\$0	TOTAL FOR ORGANIZATION		\$1,834,757	\$110,000	\$0
\$2,228,657	\$1,834,757	\$1,813,124	\$0	TOTAL FOR AGENCY	999	\$1,834,757	\$110,000	\$0
\$2,228,657	\$1,834,757	\$1,813,124	\$0	TOTAL FOR FUND	306	\$1,834,757	\$110,000	\$0

EXPENSE BUDGET BY OBJECT

FUND. 306 FBFCMSC DEBT SERVICE-COUNTY AGENCY: 777 DEBT SERVICE
 ORG. 7106 FBFCMSC DEBT SVC-COUNTY ACTIVITY: 3100 PRINCIPAL RETIREMENT FUNC

* * * * *		* * * * *		* * * * *		* * * * *	
BUDGET AS MODIFIED	EXP THRU 10/22/99	TOTAL EST EXPENDITURE	ACCOUNT NAME	OBJECT	BUDGET REQUEST	RECOM ENDED	ADOPTED BUDGET
\$802,951	\$1,100,000	\$0	\$0 PAYMENT ON PRINCIPAL	7016	\$1,100,000	\$0	\$0
\$802,951	\$1,100,000	\$0		TOTAL	\$1,100,000	\$0	\$0
\$802,951	\$1,100,000	\$0	TOTAL FOR ACTIVITY	3100	\$1,100,000	\$0	\$0
\$802,951	\$1,100,000	\$0	TOTAL FOR ORGANIZATION	7106	\$1,100,000	\$0	\$0

FUND. 306 FBFCMSC DEBT SERVICE-COUNTY		AGENCY: 777 DEBT SERVICE		BUDGET REQUEST		*2000* RECOM ENDED		ADOPTED BUDGET	
ORG 7506 FBFCMSC DEBT SERVICE-COUNTY		ACTIVITY: 3200 INTEREST AND FISCAL CHARGES		FUNG.					
1998 EXPENDITURE AS MODIFIED	BUDGET AS MODIFIED	1999 EXP THRU 10/22/99	TOTAL EST EXPENDITURE	ACCOUNT NAME	OBJECT	BUDGET REQUEST	*2000* RECOM ENDED	ADOPTED BUDGET	
\$1,051,182	\$1,080,033	\$0	\$0	PAYMENT ON INTEREST	7017	\$1,080,033	\$0	\$0	\$0
\$0	\$2,500	\$0	\$0	DEBT SERVICE FEES	7018	\$2,500	\$0	\$0	\$0
\$1,051,182	\$1,082,533	\$0	\$0	TOTAL		\$1,082,533	\$0	\$0	\$0
\$1,051,182	\$1,082,533	\$0	\$0	TOTAL FOR ACTIVITY	3200	\$1,082,533	\$0	\$0	\$0
\$1,051,182	\$1,082,533	\$0	\$0	TOTAL FOR ORGANIZATION	7506	\$1,082,533	\$0	\$0	\$0
\$1,854,133	\$2,182,533	\$0	\$0	TOTAL FOR AGENCY	777	\$2,182,533	\$0	\$0	\$0
\$1,854,133	\$2,182,533	\$0	\$0	TOTAL FOR FUND	306	\$2,182,533	\$0	\$0	\$0

1998 REVENUE	BUDGET AS MODIFIED	1999 REV THRU 10/22/99	TOTAL EST REVENUE	ACCOUNT NAME	REVENUE SOURCE	REVENUE REQUEST	*2000 RECOM ENDED	ADOPTED REVENUE
\$6,303	\$6,000	\$4,647		PENALTY & INTEREST-PROP TX	OPPI	\$6,000	\$6,000	
\$16,691	\$14,000	\$11,067		PROPERTY TAXES - DELINQUENT	00GD	\$14,000	\$14,000	
\$699,392	\$694,953	\$697,588		PROPERTY TAXES - CURRENT	00GP	\$694,953		
\$10,457	\$10,000	\$7,256		INTEREST EARNED	00IE	\$10,000	\$10,000	
\$732,843	\$724,953	\$720,558	\$0		TOTL	\$724,953	\$30,000	\$0
\$732,843	\$724,953	\$720,558	\$0	TOTAL FOR ORGANIZATION		\$724,953	\$30,000	\$0
\$732,843	\$724,953	\$720,558	\$0	TOTAL FOR AGENCY	999	\$724,953	\$30,000	\$0
\$732,843	\$724,953	\$720,558	\$0	TOTAL FOR FUND	309	\$724,953	\$30,000	\$0

EXPENSE BUDGET BY OBJECT

FUND: 309 FBFCMSC REVENUE BONDS - '95 AGENCY: 777 DEBT SERVICE FUNC:
 ORG 7109 FBFCMSC REVENUE BONDS '95 ACTIVITY: 3100 PRINCIPAL RETIREMENT

1998	BUDGET AS MODIFIED	EXP THRU 10/22/99	1999	TOTAL EST EXPENDITURE	ACCOUNT NAME	OBJECT	BUDGET REQUEST	RECOM ENDED	ADOPTED BUDGET
\$390,000	\$410,000	\$0	\$0	\$0	PAYMENT ON PRINCIPAL	7016	\$410,000	\$440,000	\$440,000
\$390,000	\$410,000	\$0	\$0	\$0	TOTL		\$410,000	\$440,000	\$440,000
\$390,000	\$410,000	\$0	\$0	\$0	TOTAL FOR ACTIVITY	3100	\$410,000	\$440,000	\$440,000
\$390,000	\$410,000	\$0	\$0	\$0	TOTAL FOR ORGANIZATION	7109	\$410,000	\$440,000	\$440,000

** COUNTY BOND COUNTY **
 EXPENSE BUDGET BY OBJECT

FUND. 309 FBFCMSC REVENUE BONDS - '95 AGENCY. 777 DEBT SERVICE
 ORG. 7509 FBFCMSC REVENUE BONDS '95 ACTIVITY: 3200 INTEREST AND FISCAL CHARGES FUNC.

1998	BUDGET	EXP THRU	1999	TOTAL EST	ACCOUNT NAME	OBJECT	BUDGET	RECOM	ADOPTED
EXPENDITURE AS MODIFIED		10/22/99	EXPENDITURE				REQUEST	ENDED	BUDGET
\$332,458	\$312,453	\$0	\$0	\$0	\$0 PAYMENT ON INTEREST	7017	\$312,453	\$290,770	\$290,770
\$0	\$2,500	\$0	\$0	\$0	\$0 DEBT SERVICE FEES	7018	\$2,500	\$2,700	\$2,700
\$332,458	\$314,953	\$0	\$0	\$0		TOTL	\$314,953	\$293,470	\$293,470
\$332,458	\$314,953	\$0	\$0	\$0	TOTAL FOR ACTIVITY	3200	\$314,953	\$293,470	\$293,470
\$332,458	\$314,953	\$0	\$0	\$0	TOTAL FOR ORGANIZATION	7509	\$314,953	\$293,470	\$293,470
\$722,458	\$724,953	\$0	\$0	\$0	TOTAL FOR AGENCY	777	\$724,953	\$733,470	\$733,470
\$722,458	\$724,953	\$0	\$0	\$0	TOTAL FOR FUND	309	\$724,953	\$733,470	\$733,470

** REVENUE BUDGET **
REVENUE BUDGET BY REVENUE SOURCE

RUN DATE: 22 OCT 99
LN 1 13

FUND. 310 DEBT SERVICE
ORG

AGENCY. 999 REVENUE
ACTIVITY:

1998 REVENUE	BUDGET AS MODIFIED	1999 REV THRU 10/22/99	TOTAL EST REVENUE	ACCOUNT NAME	REVENUE SOURCE	REVENUE REQUEST	*2000 RECOM ENDED	ADOPTED REVENUE
\$43,647	\$42,000	\$26,422		PENALTY & INTEREST-PROP TX	OPPI	\$42,000	\$40,000	
\$115,586	\$100,000	\$62,916		PROPERTY TAXES - DELINQUENT	00GD	\$100,000	\$100,000	
\$4,848,325	\$3,948,321	\$3,965,963		PROPERTY TAXES - CURRENT	00GP	\$3,948,321		
\$217,364	\$190,000	\$127,888		INTEREST EARNED	00IE	\$190,000	\$190,000	
\$55,629	\$56,120	\$48,268		REIMBURSEMENTS-MISCELLANEOUS	00RE	\$56,120	\$53,320	
\$0	\$0	\$0		OPERATING TRANSFERS IN	00TR	\$0	\$0	
\$5,280,551	\$4,336,441	\$4,231,457	\$0		TOTL	\$4,336,441	\$383,320	\$0
\$5,280,551	\$4,336,441	\$4,231,457	\$0	TOTAL FOR ORGANIZATION		\$4,336,441	\$383,320	\$0
\$5,280,551	\$4,336,441	\$4,231,457	\$0	TOTAL FOR AGENCY	999	\$4,336,441	\$383,320	\$0
\$5,280,551	\$4,336,441	\$4,231,457	\$0	TOTAL FOR FUND	310	\$4,336,441	\$383,320	\$0

EXPENSE BUDGET BY OBJECT

FUND. 310 DEBT SERVICE		AGENCY. 777 DEBT SERVICE		ACTIVITY: 3200 INTEREST AND FISCAL CHARGES		FUNC.		
ORG: 7778 DEBT SERVICE - INTEREST & FEES	BUDGET AS MODIFIED	EXP THRU 10/22/99	TOTAL EST EXPENDITURE	ACCOUNT NAME	OBJECT	BUDGET REQUEST	RECOM ENDED	ADOPTED BUDGET
\$65,723	\$40,536	\$0	\$0	\$0 INTEREST LIB PERM/IMPR '97050	'97050	\$40,536	\$13,800	\$13,800
\$23,720	\$21,120	\$0	\$0	\$0 INTEREST FAIR ARENA '91	7051	\$21,120	\$18,320	\$18,320
\$383,500	\$331,500	\$0	\$0	\$0 INTEREST JAIL PERM/I '92	7052	\$331,500	\$279,500	\$279,500
\$1,591,938	\$1,547,868	\$0	\$0	\$0 INTEREST PERM/IMPR REF '97053	'97053	\$1,547,868	\$1,501,948	\$1,501,948
\$272,775	\$272,775	\$0	\$0	\$0 INTEREST NEW LIB BDS '96	7054	\$272,775	\$261,375	\$261,375
\$55,595	\$43,040	\$0	\$0	\$0 INTEREST EAST END ANNEX '7055	'7055	\$43,040	\$29,460	\$29,460
\$2,083	\$2,100	\$0	\$0	\$0 FEES LIB PERM/IMPR '90	7070	\$2,100	\$2,300	\$2,300
\$1,909	\$2,000	\$0	\$0	\$0 FEES FAIR ARENA '91	7071	\$2,000	\$2,200	\$2,200
\$1,184	\$1,500	\$0	\$0	\$0 FEES JAIL PERM/I '92	7072	\$1,500	\$1,700	\$1,700
\$1,821	\$1,500	\$0	\$0	\$0 FEES PERM/IMPR REF '93	7073	\$1,500	\$1,700	\$1,700
\$200	\$1,000	\$0	\$0	\$0 FEES NEW LIB BDS '96	7074	\$1,000	\$1,200	\$1,200
\$2,040	\$1,500	\$0	\$0	\$0 FEES EAST END ANNEX '96	7075	\$1,500	\$1,700	\$1,700
\$2,402,488	\$2,266,441	\$0	\$0	TOTL	TOTL	\$2,266,441	\$2,115,203	\$2,115,203
\$2,402,488	\$2,266,441	\$0	\$0	TOTAL FOR ACTIVITY	3200	\$2,266,441	\$2,115,203	\$2,115,203
\$2,402,488	\$2,266,441	\$0	\$0	TOTAL FOR ORGANIZATION	7778	\$2,266,441	\$2,115,203	\$2,115,203
\$4,977,488	\$5,036,441	\$0	\$0	TOTAL FOR AGENCY	777	\$5,036,441	\$5,020,203	\$5,020,203
\$4,977,488	\$5,036,441	\$0	\$0	TOTAL FOR FUND	310	\$5,036,441	\$5,020,203	\$5,020,203

FUND. 311 FBFCWSC REVENUE REFUNDING 1999
 ORG

1998 REVENUE	BUDGET AS MODIFIED	1999 REV THRU 10/22/99	TOTAL EST REVENUE	ACCOUNT NAME	REVENUE SOURCE	REVENUE REQUEST	*2000 RECOM ENDED	ADOPTED REVENUE
\$0	\$0	\$2,822		PENALTY & INTEREST-PROP TX	0PPI	\$0	\$0	\$0
\$0	\$0	\$11,333		PROPERTY TAXES - DELINQUENT	00GD	\$0	\$0	\$0
\$0	\$0	\$0		PROPERTY TAXES - CURRENT	00GP	\$0	\$0	\$0
\$0	\$0	\$14,155	\$0	TOTAL	TOTL	\$0	\$0	\$0
\$0	\$0	\$14,155	\$0	TOTAL FOR ORGANIZATION		\$0	\$0	\$0
\$0	\$0	\$14,155	\$0	TOTAL FOR AGENCY	999	\$0	\$0	\$0
\$0	\$0	\$14,155	\$0	TOTAL FOR FUND	311	\$0	\$0	\$0

EXPENSE BUDGET BY OBJECT

FUND 311 FBFCMSC REVENUE REFUNDING 1999 AGENCY: 777 DEBT SERVICE
 ORG 7110 FBFCMSC REFUNDING '99 ACTIVITY: 3100 PRINCIPAL RETIREMENT

1998		1999		TOTAL EST		RECOM		BUDGET		ADOPTE	
BUDGET	AS MODIFIED	EXP THRU	10/22/99	EXPENDITURE	PAYMENT ON PRINCIPAL	ACCOUNT NAME	ENDED	REQUEST	BUDGET	BUDGET	BUDGET
\$0	\$0	\$0	\$0	\$0	\$0	TOTAL FOR ACTIVITY	\$1,260,000	\$0	\$1,260,000	\$1,260,000	\$1,260,000
\$0	\$0	\$0	\$0	\$0	\$0	TOTAL FOR ORGANIZATION	\$1,260,000	\$0	\$1,260,000	\$1,260,000	\$1,260,000

FUND: 311 FBFCMSC REVENUE REFUNDING 1999	AGENCY: 777 DEBT SERVICE	BUDGET	EXP THRU	TOTAL EST	BUDGET REQUEST	RECOM ENDED	ADOPTED BUDGET
ORG. 7510 FBFCMSC REFUNDING '99	ACTIVITY: 3200 INTEREST AND FISCAL CHARGES	AS MODIFIED	10/22/99	EXPENDITURE	7017	\$710,436	\$710,436
\$0		\$0	\$0	\$0	\$0	\$2,500	\$2,500
\$0		\$0	\$0	\$0	TOTAL	\$712,936	\$712,936
\$0		\$0	\$0	\$0	TOTAL FOR ACTIVITY	\$712,936	\$712,936
\$0		\$0	\$0	\$0	TOTAL FOR ORGANIZATION	\$712,936	\$712,936
\$0		\$0	\$0	\$0	TOTAL FOR AGENCY	\$1,972,936	\$1,972,936
\$0		\$0	\$0	\$0	TOTAL FOR FUND	\$1,972,936	\$1,972,936

COMMISSIONERS COURT AGENDA REQUEST FORM

RETURN TO: AGENDA COORD.-COUNTY JUDGE'S OFFICE

DATE SUBMITTED: 10/5/99

SUBMITTED BY: Ann Werlein

AGENDA

DEPARTMENT: Co. Judge

ITEM

COURT AGENDA DATE: 10/12/99

PHONE NO.: 281-341-8608

16A

SUMMARY OF ITEM:

Discuss and Consider approving \$10,000 to be paid to Texana MHMR to assist in the payment of a consultant hired to recruit an Executive Director for Texana. Total cost estimated \$15,000-\$17,000. Fort Bend County portion

RENEWAL CONTRACT/AGREEMENT: Yes () No based on population would be 70% or \$11,900

LIST SUPPORTING DOCUMENTS ATTACHED: Request letter from Texana.

FINANCIAL SUMMARY:

BUDGETED ITEM:	ANNUALIZED DOLLARS.	COMMENTS
Yes () No <input checked="" type="checkbox"/> N/A ()	One Time <input checked="" type="checkbox"/>	
Funding Source:	Recurring ()	
fund <u>010</u> agcy <u>045</u> Object <u>4010</u>	N/A ()	

Original Form Submitted with back up to County Judge's Office: Yes ()

CC with back up:

yes () Auditor	(281-341-3774)	yes () Comm. Pct. 1	(281-342-0587)
yes () Budget Officer	(281-344-3954)	yes () Comm. Pct. 2	(281-403-8009)
yes () County Attorney	(281-341-4557)	yes () Comm. Pct. 3	(281-242-9060)
yes () Purchasing Agent	(281-341-8642)	yes () Comm Pct. 4	(281-980-9077)

Instructions for submitting an Agenda Request

- 1 Completely fill out agenda form, incomplete forms will not be processed
- 2 Fax or inter-office copies of agenda form with all back up information by Wednesday at 2.00 p m to the departments listed above.
- 3 All original back-up must be received in the County Judges Office by 2 00 p m on Wednesday

RECOMMENDATION / ACTION REQUESTED:



10-04-99 05:15:23

TO COMMISSIONERS COURTS OF AUSTIN, COLORADO, FORT
BEND, MATAGORDA, WALLER AND WHARTON
COUNTIES

FROM TEXANA MHMR CENTER BOARD

DATE OCTOBER 3, 1999

RE FUNDING SUPPORT

Recently, the Texana MHMR Center Board tentatively contracted with Trace Consultants to conduct a search for an Executive Director for the center. Mr. Clyde Jacks is the principal of Trace Consultants. He agreed to reduce his fee to 15% of the annual salary plus minimal expenditures. The total cost is estimated to be between \$15,000-\$17,000.

If at all possible, the Texana Board requests that you place the matter on your commissioners court agenda by October 15 for approval of funds for this service. We are asking that you approve a pro-rata share based on population or by whatever formula you deem appropriate. The board is also seeking grant funds as well as a portion from the center's budget.

Please contact me at 1-409-245-6282 if you require a member of the board to make a formal presentation before your court or require additional information.

Sincerely,

Ann Uher
Board Chair

**FORT BEND COUNTY
COMMISSIONERS COURT AGENDA REQUEST FORM
RETURN TO: AGENDA COORD.-COUNTY JUDGE'S OFFICE**

DATE SUBMITTED: 9-17-99

SUBMITTED BY: JOHN KNEX
DEPARTMENT: County Judge
PHONE NO.: 341-8606

AGENDA
ITEM
#16B

COURT AGENDA DATE: 10-12-99

SUMMARY OF ITEM. RESOLUTION TO NOMINATE CANDIDATES FOR THE CENTRAL APPRAISAL DISTRICT BOARD OF DIRECTORS.

RENEWAL CONTRACT/AGREEMENT Yes () No ()

LIST SUPPORTING DOCUMENTS ATTACHED: MEMO FROM JUDGE ADOLPHUS TO COMMISSIONERS WITH ATTACHMENTS. SAMPLE RESOLUTION FROM 1997.

FINANCIAL SUMMARY:

BUDGETED ITEM	ANNUALIZED DOLLARS:	COMMENTS.
Yes () No () N/A ()	One Time ()	
Funding Source: fund _____ agcy _____ Object _____	Recurring ()	
	N/A ()	

Original Form Submitted with back up to County Judge's Office: Yes (X)

CC with back up:

yes () Auditor	(281-341-3774)	yes (X) Comm. Pct. 1	(281-342-0587)
yes () Budget Officer	(281-344-3954)	yes (X) Comm. Pct. 2	(281-403-8009)
yes () County Attorney	(281-341-4557)	yes (X) Comm. Pct. 3	(281-242-9060)
yes () Purchasing Agent	(281-341-8642)	yes (X) Comm. Pct. 4	(281-980-9077)

Instructions for submitting an Agenda Request:

- 1 Completely fill out agenda form, incomplete forms will not be processed
- 2 Fax or inter-office copies of agenda form with all back up information by Wednesday at 2:00 p.m. to the departments listed above
- 3 All original back-up must be received in the County Judges Office by 2:00 p.m. on Wednesday.

RECOMMENDATION / ACTION REQUESTED:

10-20-99 Original Resolution sent to Appraisal District

RESOLUTION

At a regular meeting of Fort Bend County Commissioners Court on Tuesday, October 14, 1997, the following Resolution was adopted

RESOLVED, that Commissioners Court of Fort Bend County, Texas nominates the following persons to serve on the Board of Directors of the Fort Bend Central Appraisal District as follows:

~~James Baker
1135 Lindsey Dr
Rosenberg, Texas 77471~~

~~Kenneth Martindale
15115 Steeplechase Rd
Missouri City, Texas 77489~~

~~Dr. George Woodley
1102 Alkire Lake Dr
Sugar Land, Texas 77478~~

~~Lee Duggan III
6440 Oilfield Road
Sugar Land, Texas 77479~~

SAMPLE

Passed and Approved this **14th** day of **October, 1997**.

FORT BEND COUNTY COMMISSIONERS COURT

Mike D. Rozell

Michael D Rozell, County Judge

ATTEST:

Dianne Wilson

Dianne Wilson, County Clerk

RESOLUTION

At a regular meeting of Fort Bend County Commissioners Court on Tuesday, October 12, 1999, the following Resolution was adopted

RESOLVED, that Commissioners Court of Fort Bend County, Texas nominates the following persons to serve on the Board of Directors of the Fort Bend Central Appraisal District as follows

James Baker
1135 Lindsey Dr
Rosenberg, Texas 77471

Kenneth Martindale
15115 Steeplechase Rd
Missouri City, Texas 77489

Dr George Woodley
1102 Alkire Lake Dr
Sugar Land, Texas 77478

Lee Duggan, III
6440 Oilfield Road
Sugar Land, Texas 77479

Orin N Covell
915 Bent Creek Ct
Richmond, Texas 77469

Passed and Approved this 12th day of October, 1999
Fort Bend County Commissioners Court

James C Adolphus, County Judge

ATTEST.

Dianne Wilson, County Clerk



COUNTY JUDGE

Fort Bend County, Texas

James C Adolphus
County Judge

(281) 341-8608
Fax (281) 341-8609

TO County Commissioners

FROM James C Adolphus, County Judge

DATE September 17, 1999

SUBJECT Nominations for Central Appraisal District Board of Directors

Please note the attached Nominating Notice for BOD Candidates from the Central Appraisal District. The county can nominate as many as 5 candidates no later than 10-15-99. We will include an agenda item for the 10-12-99 Commissioners Court for our nominating resolution.

Also attached is the first page of the results sheet from the 1998 BOD election, and the attendance records of the 5 voting directors. The Tax Assessor/Collector is a non-voting member of the BOD.

Nominations by 10-15-99, voting before 11-15-99

**FORT BEND CENTRAL APPRAISAL DISTRICT
2801 B.F. TERRY BLVD.
ROSENBERG, TEXAS 77471-5600
281-344-8623 (FAX) 281-344-8632**

**BOARD OF DIRECTORS NOMINATING NOTICE
2000 – 2001**

**Subject: Nominating notice for candidate(s) to serve on the Board of
Directors for FORT BEND CAD 2000 – 2001 term of office.**

GOVERNMENT BODY: FORT BEND COUNTY

NOTICE

YOU ARE ENTITLED TO NOMINATE ONE CANDIDATE FOR EACH POSITION TO BE FILLED ON THE BOARD OF DIRECTORS. THERE ARE CURRENTLY FIVE POSITIONS ON THE BOARD.

NOMINATIONS MUST BE RESOLUTION ADOPTED BY YOUR GOVERNING BODY AND RETURNED TO THE FORT BEND CAD NO LATER THAN OCTOBER 15, 1999. PRIOR TO OR NO LATER THAN OCTOBER 30, 1999 YOU WILL RECEIVE A BALLOT LISTING THE CANDIDATES NOMINATED.

YOUR ENTITY WILL HAVE UNTIL NOVEMBER 15, 1999 TO VOTE BY RESOLUTION AND NOTIFY THE CHIEF APPRAISER OF YOUR VOTE.

THE VOTE ENTITLEMENT FOR **FORT BEND COUNTY** WILL BE {1072} VOTES.

MR. WILLIAM A. LITTLE HAS BEEN NOMINATED BY THE MUD AND LID DISTRICTS AND WILL APPEAR ON THE BALLOT.

TAXING JURISDICTIONS	JAMES A BAKER	LEE DUGGAN III	HARRIS H JOHNSTON JR.	WILLIAM A LITTLE	KENNETH MARTINDALE	ALLEN E ROBINSON	DR. GEORGE WOODLEY, JR.
FBC COMMISSIONERS COURT	80	333			332		333
CITY OF ARCOLA							
CITY OF FULSHEAR							
CITY OF MEADOWS						18	
CITY OF MISSOURI CITY						138	
CITY OF NEEDVILLE	4						
CITY OF ROSENBERG	40						
CITY OF RICHMOND	21						
CITY OF SUGAR LAND			75				75
FORT BEND I S D		455		530	455		379
KENDLETON I S D							18
LAMAR C I S D	660						
NEEDVILLE I S D	40						
STAFFORD M S D							
WHARTON JR COLLEGE							
HOUSTON COM COLLEGE							
FB MUD #1				131			
FB MUD #10							
FB MUD #19							
FB MUD #21							
FB MUD #23							
FB MUD #25							
FB MUD #26							
FB MUD #27							
FB MUD #30							
FB MUD #34				6			
FB MUD #37							
FB MUD #41							

ALL HANDS/4ERS & R: VOTING

38

AS PER ORIGINAL

1998 / 1999 BOARD OF DIRECTORS ATTENDANCE RECORDS

AS PER ORIGINAL

	W.A. LITTLE	J.A. BAKER	G.H. WOODLEY	K. R. MARTINDALE	L.E. DUGGAN	M.P. GAINES
JANUARY	HERE	HERE	X	HERE	HERE	X
FEBRUARY	HERE	HERE	HERE	X	HERE	X
MARCH	X	HERE	HERE	HERE	HERE	HERE
APRIL	HERE	HERE	HERE	HERE	X	X
MAY	HERE	HERE	HERE	X	HERE	X
JUNE	NO MEETING	NO MEETING	NO MEETING	NO MEETING	NO MEETING	NO MEETING
JULY	HERE	HERE	X	X	HERE	X
AUGUST	HERE	HERE	HERE	X	HERE	HERE
SEPTEMBER	HERE	HERE	HERE	X	HERE	X
OCTOBER	HERE	HERE	HERE	X	X	X
NOVEMBER	NO MEETING	NO MEETING	NO MEETING	NO MEETING	NO MEETING	NO MEETING
DECEMBER	HERE	HERE	X	HERE	HERE	X
JANUARY	HERE	HERE	HERE	X	HERE	HERE
FEBRUARY	NO MEETING	NO MEETING	NO MEETING	NO MEETING	NO MEETING	NO MEETING
MARCH	HERE	HERE	HERE	X	HERE	X
APRIL	HERE	HERE	HERE	HERE	HERE	X
MAY	HERE	HERE	HERE	X	HERE	HERE
JUNE	HERE	HERE	HERE	HERE	HERE	HERE
JULY	HERE	HERE	HERE	X	X	X
AUGUST	HERE	HERE	X	X	HERE	HERE

16/17 94%
 17/17 100%
 13/17 77%
 6/17 35%
 14/17 82%
 6/17 35%

COMMISSIONERS COURT AGENDA REQUEST FORM

RETURN TO: AGENDA COORD.-COUNTY JUDGE'S OFFICE

DATE SUBMITTED: 10 6 99

SUBMITTED BY: County Attorney

AGENDA
ITEM

COURT AGENDA DATE: 10.12.99

DEPARTMENT: _____

PHONE NO.: 4556

17

SUMMARY OF ITEM:

Discuss and consider granting permission to Rosenberg Rentalization Assoc for use of parking lot at FBC Rosenberg Annex for annual Christmas magic event parking

RENEWAL CONTRACT/AGREEMENT: Yes () No ()

LIST SUPPORTING DOCUMENTS ATTACHED:

FINANCIAL SUMMARY:

BUDGETED ITEM:	ANNUALIZED DOLLARS	COMMENTS:
Yes () No () N/A ()	One Time ()	
Funding Source: fund _____ agcy _____ Object _____	Recurring ()	
	N/A ()	

Original Form Submitted with back up to County Judge's Office: Yes ()

CC with back up:

yes () Auditor	(281-341-3774)	yes () Comm. Pct. 1	(281-342-0587)
yes () Budget Officer	(281-344-3954)	yes () Comm. Pct. 2	(281-403-8009)
yes () County Attorney	(281-341-4557)	yes () Comm. Pct. 3	(281-242-9060)
yes () Purchasing Agent	(281-341-8642)	yes () Comm. Pct. 4	(281-980-9077)

Instructions for submitting an Agenda Request

- 1 Completely fill out agenda form, incomplete forms will not be processed.
- 2 Fax or inter-office copies of agenda form with all back up information by Wednesday at 2:00 p.m. to the departments listed above
- 3 All original back-up must be received in the County Judges Office by 2 00 p.m on Wednesday

RECOMMENDATION / ACTION REQUESTED:

10-20-99 Original Full Release sent to Assoc at the County Attorneys Office.

THE STATE OF TEXAS §
COUNTY OF FORT BEND §

KNOW ALL MEN BY THESE PRESENTS

FULL RELEASE

This Full Release is made and entered into by and between FORT BEND COUNTY, TEXAS (hereinafter referred to as "County"), and Rosenberg Revitalization Association (hereinafter referred to as "Association");

WHEREAS, the County desires to permit the Association to use Fort Bend County's property located at 4520 Reading Road, Rosenberg, Texas for satellite parking for the Association's "Christmas Magic" event on Saturday, November 27, 1999 for a public purpose; and,

WHEREAS, the Association desires to fully release the County of any future claims that may be derived from the use of the parking lot; and,

LIABILITY INSURANCE

Association shall, keep in full force and effect a policy or general liability insurance in which the limits shall not be less than \$1,000,000 for each claim aggregate. The policy shall name County, and shall contain a clause that the insurer will not cancel or change the insurance without first giving County ten (10) days prior written notice. The insurance shall be in a company acceptable to the Fort Bend County Insurance Department and a copy of the policy or certification of insurance shall be delivered to County on or before the date of this agreement.

WHEREAS, the parties agree the purpose of the release is to buy peace,

NOW THEREFORE, in consideration of the recitals set forth above, the Association has this day released and by these presents do release, acquit, and forever discharge the County, its officials, agents, servants, and employees and all persons in privity with the County from any and all future claims or causes of action of any kind whatsoever, at common law, statutory or otherwise, which might arise hereafter, directly or indirectly attributable to the Associations' Christmas Magic event on Saturday, November 27, 1999.

The Association agrees to and shall indemnify defend and hold harmless the County and its elected officials, officers, employees and agents, from and against any and all claims, losses, damage, causes of action, suits, and liability of any kind, including all expenses of litigation, court costs, attorney's fees, bodily injury, sickness, disease or death as a result of the Association's use of the County's parking lot located at 4520 Reading Road, Rosenberg, Texas, Saturday, November 27, 1999

EXECUTED this the 12th day of October, 1999

FORT BEND COUNTY, TEXAS
By: [Signature]
James C. Adolphus, County Judge
Date: 10/12/99

ATTEST: [Signature]
Dianne Wilson, County Clerk

ROSENBERG REVITALIZATION ASSOCIATION
By: [Signature]
Date: 6 Oct 99

ACORD™ CERTIFICATE OF LIABILITY INSURANCE

AS PER ORIGINAL DATE (MM/DD/YY)

9-30-99

PRODUCER
 Charles Marietta Insurance Center
 P.O. Box 1126
 Rosenberg, Texas 77471
 PH: 281-342-4666 FAX: 281-342-4678

THIS CERTIFICATE IS ISSUED AS A MATTER OF INFORMATION ONLY AND CONFERS NO RIGHTS UPON THE CERTIFICATE HOLDER. THIS CERTIFICATE DOES NOT AMEND, EXTEND OR ALTER THE COVERAGE AFFORDED BY THE POLICIES BELOW

INSURERS AFFORDING COVERAGE

INSURED
 Rosenberg Revitalization Association &
 Rosenberg Railroad Museum
 P.O. Box 607
 Rosenberg, Texas 77471

INSURER A Burlington Insurance Company
 INSURER B
 INSURER C
 INSURER D
 INSURER E

COVERAGES

THE POLICIES OF INSURANCE LISTED BELOW HAVE BEEN ISSUED TO THE INSURED NAMED ABOVE FOR THE POLICY PERIOD INDICATED NOTWITHSTANDING ANY REQUIREMENT, TERM OR CONDITION OF ANY CONTRACT OR OTHER DOCUMENT WITH RESPECT TO WHICH THIS CERTIFICATE MAY BE ISSUED OR MAY PERTAIN THE INSURANCE AFFORDED BY THE POLICIES DESCRIBED HEREIN IS SUBJECT TO ALL THE TERMS EXCLUSIONS AND CONDITIONS OF SUCH POLICIES AGGREGATE LIMITS SHOWN MAY HAVE BEEN REDUCED BY PAID CLAIMS

INSR LTR	TYPE OF INSURANCE	POLICY NUMBER	POLICY EFFECTIVE DATE (MM/DD/YY)	POLICY EXPIRATION DATE (MM/DD/YY)	LIMITS
	GENERAL LIABILITY				EACH OCCURRENCE \$ 1,000,000.00
A. <input checked="" type="checkbox"/>	COMMERCIAL GENERAL LIABILITY	B0179G413141	11-27-99	11-28-99	FIRE DAMAGE (Any one fire) \$ 50,000.00
	CLAIMS MADE OCCUR				MED EXP (Any one person) \$ 1,000.00
					PERSONAL & ADV INJURY \$ 1,000,000.00
					GENERAL AGGREGATE \$ 1,000,000.00
					PRODUCTS COMP/OP AGG \$ 1,000,000.00
	AUTOMOBILE LIABILITY				COMBINED SINGLE LIMIT (Ea accident) \$
	ANY AUTO				BODILY INJURY (Per person) \$
	ALL OWNED AUTOS				BODILY INJURY (Per accident) \$
	SCHEDULED AUTOS				PROPERTY DAMAGE (Per accident) \$
	HIRED AUTOS				
	NON OWNED AUTOS				
	GARAGE LIABILITY				AUTO ONLY EA ACCIDENT \$
	ANY AUTO				OTHER THAN AUTO ONLY EA ACC AGG \$
	EXCESS LIABILITY				EACH OCCURRENCE \$
	OCCUR CLAIMS MADE				AGGREGATE \$
	DEDUCTIBLE				\$
	RETENTION \$				\$
	WORKERS COMPENSATION AND EMPLOYERS LIABILITY				WC STATUTORY LIMITS CTH ER
					E L EACH ACCIDENT \$
					E L DISEASE EA EMPLOYEE \$
					E L DISEASE POLICY LIMIT
	OTHER				

DESCRIPTION OF OPERATIONS/LOCATIONS/VEHICLES/EXCLUSIONS ADDED BY ENDORSEMENT/SPECIAL PROVISIONS

CHRISTMAS MAGIC - One Day Event - 11-27-99

Additional Insured: City of Rosenberg and Fort Bend County

CERTIFICATE HOLDER ADDITIONAL INSURED INSURER LETTER

Fort Bend County
 501 Jackson
 Richmond, Texas 77469

ATT Bud Childers

CANCELLATION

SHOULD ANY OF THE ABOVE DESCRIBED POLICIES BE CANCELLED BEFORE THE EXPIRATION DATE THEREOF THE ISSUING INSURER WILL ENDEAVOR TO MAIL 14 DAYS WRITTEN NOTICE TO THE CERTIFICATE HOLDER NAMED TO THE LEFT BUT FAILURE TO DO SO SHALL IMPOSE NO OBLIGATION OR LIABILITY OF ANY KIND UPON THE INSURER ITS AGENTS OR REPRESENTATIVES

AUTHORIZED REPRESENTATIVE *Charles J. Marietta*
 Charles J. Marietta

**FORT BEND COUNTY
COMMISSIONERS COURT AGENDA REQUEST FORM
RETURN TO: AGENDA COORD -COUNTY JUDGE'S OFFICE**

DATE SUBMITTED: <u>10/06/99</u>	SUBMITTED BY: <u>M. Kindell mkindell</u>	AGENDA ITEM # <u>18A</u>
COURT AGENDA DATE: <u>10/12/99</u>	DEPARTMENT: <u>Community Development</u>	
	PHONE NO: <u>341-4410</u>	

SUMMARY OF ITEM: Reduction in Contract Sum, Change Order No 1, \$2,007 00, Bass Construction Co , for construction of the Precinct 1 Community Center Building Contract awarded to Bass Construction by Commissioners Court 3/2/99, FBC Bid #99-025 Project approved by Commissioners Court in the FY 1997 Consolidated Action Plan 7/8/97 Increase in Contract Time, 137 days to February 15, 2000

RENEWAL CONTRACT/AGREEMENT: Yes () No (X)

LIST SUPPORTING DOCUMENTS ATTACHED: Change Order No. 1, \$2,007.00

FINANCIAL SUMMARY:

BUDGETED ITEM:	ANNUALIZED DOLLARS	COMMENTS:
Yes (X) No () N/A ()	One Time ()	
Funding Source:	Recurring ()	
Fund <u>840</u> Agcy <u>101</u> Object <u>8040</u>	N/A ()	

Original Form Submitted with back up to County Judge's Office: Yes (X)

CC with back up:

yes (X) Auditor	(281-341-3774)	yes (X)	Comm. Pct. 1	(281-342-0587)
yes (X) Budget Officer	(281-344-3954)	yes (X)	Comm. Pct. 2	(281-403-8009)
yes (X) County Attorney	(281-341-4557)	yes (X)	Comm. Pct. 3	(281-242-9060)
yes (X) Purchasing Agent	(281-341-8642)	yes (X)	Comm. Pct. 4	(281-980-9077)

- Instructions for submitting an Agenda Request:**
1. Completely fill out agenda form, incomplete forms will not be processed.
 2. Fax or inter-office copies of agenda form with all back up information by Wednesday at 2:00 p.m. to the departments listed above.
 3. All original back-up must be received in the County Judges Office by 2:00 p.m on Wednesday.

RECOMMENDATION / ACTION REQUESTED:

10-12-99 Original sent to Hartfield and Bass from County Judges Office.

CHANGE ORDER

AIA DOCUMENT G701

OWNER
 ARCHITECT
 CONTRACTOR
 FIELD
 OTHER

PROJECT (name, address)	FORT BEND COUNTY PRECINCT 1 COMMUNITY CENTER 1330 BAND ROAD ROSENBERG, TEXAS	CHANGE ORDER NUMBER	ONE
TO CONTRACTOR (name, address)	BASS CONSTRUCTION CO. INC. 3014 AVENUE I, SUITE 3 ROSENBERG, TEXAS	DATE	OCTOBER 4, 1999
		ARCHITECT'S PROJECT NO	
		CONTRACT DATE	MARCH 4, 1999
		CONTRACT FOR	FORT BEND COUNTY PCT. 1 COMMUNITY CENTER

The Contract is changed as follows

SEE ATTACHED CHANGE ORDER No. ONE ITEMS FOR
ADD AND DEDUCT COSTS.

SEE ATTACHED FOR BASS CONSTRUCTION REQUEST FOR
CONTRACT TIME EXTENSION.

Not valid until signed by the Owner, Architect and Contractor.

The original (Contract Sum) (XXXXXXXXXXXXXXXXXXXX) was	\$	1,185,877.00
Net change by previously authorized Change Orders	\$	-0-
The (Contract Sum) (XXXXXXXXXXXXXXXXXXXX) prior to this Change Order was	\$	1,185,877.00
The (Contract Sum) (XXXXXXXXXXXXXXXXXXXX) will be (increased) (decreased)		
(XXXXXXXX) by this Change Order in the amount of	\$	2,007.00
The new (Contract Sum) (XXXXXXXXXXXXXXXXXXXX) including this Change Order will be	\$	1,183,870.00
The Contract Time will be (increased) (XXXXXXXXXXXXXXXXXXXX) by		(137) days
The date of Substantial Completion as of the date of this Change Order therefore is		FEBRUARY 15, 2000

NOTE This summary does not reflect changes in the Contract Sum, Contract Time or Guaranteed Maximum Price which have been authorized by Construction Change Directive

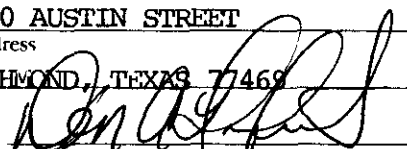
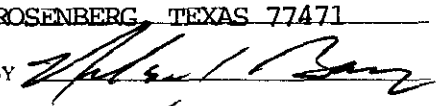
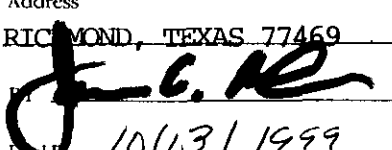
DON A. HARTFIEL AIA ARCHITECT	BASS CONSTRUCTION CO., INC.	FORT BEND COUNTY
ARCHITECT	CONTRACTOR	OWNER
1000 AUSTIN STREET	3014 AVENUE I, SUITE 3	309 S. 4th STREET
Address	Address	Address
RICHMOND, TEXAS 77469	ROSENBERG, TEXAS 77471	RICHMOND, TEXAS 77469
BY 	BY 	BY 
DATE 10/4/99	DATE 10/4/99	DATE 10/13/1999

TRANSMITTAL LETTER

DATE: OCTOBER 4, 1999

PROJECT. FOR BEND COUNTY PRECINCT COMMUNITY CENTER
1330 BAND ROAD
ROSENBERG, TEXAS

TO: MS. MARILYNN KINDELL
FORT BEND COUNTY COMMUNITY DEVELOPMENT

WE TRANSMIT:

- HEREWITH
- IN ACCORDANCE WITH YOUR REQUEST
- UNDER SEPARATE COVER

FOR YOUR:

- APPROVAL
- REVIEW AND COMMENT
- USE
- RECORD
- INFORMATION

THE FOLLOWING:

- DRAWINGS
- SPECIFICATIONS
- CHANGE ORDER
- SHOP DRAWINGS
- SAMPLES
- SEE BELOW

COPIES	DATE	REV	DESCRIPTION
3	10/4/99		3 COPIES CHANGE ORDER #1

REMARKS:

ENCLOSED ARE 3 COPIES OF CHANGE ORDER #1 FOR YOUR REVIEW. UPON YOUR APPROVAL

PLEASE PUT ON COMMISSIONER'S COURT AGENDA FOR APPROVAL. PLEASE HAVE ONE SIGNED

COPY RETURNED TO ME AND ONE TO BASS CONSTRUCTION. CALL ME IF YOU HAVE ANY

QUESTIONS.

DON A HARTFIEL AIA ARCHITECT
POST OFFICE BOX 638
RICHMOND, TEXAS 77406-0638

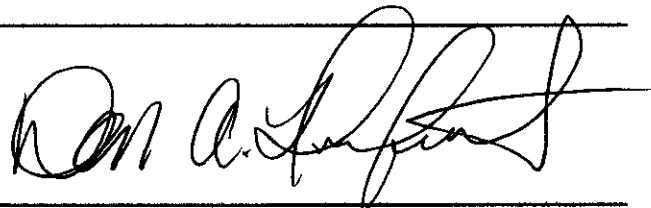

RECEIVED
OCT 04 1999
BY: *AL*

CHANGE ORDER

AIA DOCUMENT G701

OWNER
 ARCHITECT
 CONTRACTOR
 FIELD
 OTHER

AS PER ORIGINAL

PROJECT (name, address)	FORT BEND COUNTY PRECINCT 1 COMMUNITY CENTER 1330 BAND ROAD ROSENBERG, TEXAS	CHANGE ORDER NUMBER	ONE
TO CONTRACTOR (name, address)	BASS CONSTRUCTION CO. INC. 3014 AVENUE I, SUITE 3 ROSENBERG, TEXAS	DATE	OCTOBER 4, 1999
		ARCHITECT'S PROJECT NO.	
		CONTRACT DATE	MARCH 4, 1999
		CONTRACT FOR:	FORT BEND COUNTY PCT. 1 COMMUNITY CENTER

The Contract is changed as follows

SEE ATTACHED CHANGE ORDER NO. ONE ITEMS FOR ADD AND DEDUCT COSTS.

SEE ATTACHED FOR BASS CONSTRUCTION REQUEST FOR CONTRACT TIME EXTENSION.

Not valid until signed by the Owner, Architect and Contractor.

The original (Contract Sum) (XXXXXXXXXXXXXXX) was	\$	1,185,877.00
Net change by previously authorized Change Orders	\$	-0-
The (Contract Sum) (XXXXXXXXXXXXXXXXXXXX) prior to this Change Order was	\$	1,185,877.00
The (Contract Sum) (XXXXXXXXXXXXXXXXXXXX) will be (increased) (decreased) (XXXXXXXXXX) by this Change Order in the amount of	\$	2,007.00
The new (Contract Sum) (XXXXXXXXXXXXXXXXXXXX) including this Change Order will be	\$	1,183,870.00
The Contract Time will be (increased) (XXXXXXXXXXXXXXXXXX) by		(137) days.
The date of Substantial Completion as of the date of this Change Order therefore is		FEBRUARY 15, 2000

NOTE: This summary does not reflect changes in the Contract Sum, Contract Time or Guaranteed Maximum Price which have been authorized by Construction Change Directive

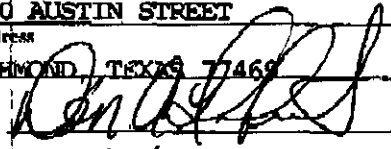
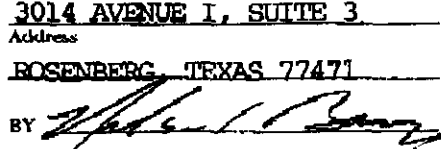
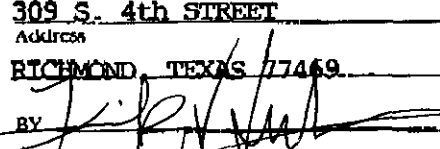
<u>DON A. HARTFIEL AIA ARCHITECT</u>	<u>BASS CONSTRUCTION CO., INC.</u>	<u>FORT BEND COUNTY</u>
ARCHITECT	CONTRACTOR	OWNER
<u>1000 AUSTIN STREET</u>	<u>3014 AVENUE I, SUITE 3</u>	<u>309 S. 4th STREET</u>
Address	Address	Address
<u>RICHMOND, TEXAS 77469</u>	<u>ROSENBERG, TEXAS 77471</u>	<u>RICHMOND, TEXAS 77469</u>
BY 	BY 	BY 
DATE <u>10/4/99</u>	DATE <u>10/4/99</u>	DATE <u>10/4/99</u>

CHANGE ORDER No. ONE ITEMS

October 4, 1999

**FORT BEND COUNTY PRECINCT 1
COMMUNITY CENTER**

Item #1 Deduct \$4,652.00 – Credit for installation of 6” water line installed by City Of Rosenberg.

Item #2 Deduct \$ 639.00 – Credit for installation of 2” PVC sanitary sewer line from lift station to manhole installed by City Of Rosenberg.

Item #3 Deduct \$1,734.00 – Credit for using revised plumbing fixture package

Item #4 Deduct \$ 500.00 – Credit for deleting removal of abandoned 6” water line.

Item #5 Deduct \$2,323.00 – Credit for deleting part of southwest concrete Parking area due to the new configuration of the new FBC Agriculture Center building.

Item #6 No Change - Use HD 18” PVC storm drainage pipe in lieu of RCP pipe – requested by City Of Rosenberg.

Total Deducts \$9,848.00

Item #7 Add \$ 143.00 – Add one 12/36 drilled pier to east end of building due Metal building manufacturer’s structural revisions.

Item #8 Add \$ 610.00 – Use 750 gallon grease trap in lieu of 500 gallon For future commercial kitchen requirements.

Item #9 Add \$1,106.00 – Add child proof covers to ends of storm sewer pipes. requested by County.

Item #10 Add \$1,414.00 – Galvanize loose brick lintels and galvanize paint Spandrel beam lintels.

Page 2

- Item #11 Add \$2,664.00 – Installation of 160 feet of 18” dia. HDPE storm drainage piping furnished by County – additional storm drainage piping installation requested by the County.**
- Item #12 Add \$ 774.00 – Revisions to east parking area due to the deletion of the east access road by the County.**
- Item #13 Add \$ 396.00 – Add door closers and ball-bearing hinges at Rooms #112,113,114,and 126 for future card access system.**
- Item #14 Add \$ 734.00 – Addition cost of concrete testing over original testing Allowance of \$3,500.00.**

Total Adds \$7,841

Change Order No. One Recap:

Deducts	\$ 9,848.00
Adds	<u>\$ 7,841.00</u>
Total C.O. #1	\$ 2,007.00 (Credit)



BASS CONSTRUCTION CO., INC.

3014 AVENUE I, SUITE 3 • ROSENBERG, TEXAS 77471 • 281-342-2022 • FAX 281-341-5071

Don A. Hartfiel AIA Architect
1000 Austin, Suite E
Richmond, Texas 77469

September 17, 1999

**RE: Various Additions and Deductions to Date
FBC Pct 1 Community center**

4/23/99	Credit 2" PVC sanitary sewer discharge line from lift station to manhole	(\$639 00)
4/23/99	Credit 6" C-900 water line	(\$4,652 00)
5/17/99	Add one each 12/36 pier	\$143 00
6/1/99	Use HD-18" PVC pipe in lieu of RCP	No Change
6/1/99	Use 750 gal 2-Compartment Grease Trap	\$610 00
6/1/99	Use Revised plumbing fixture package	(\$1,734 00)
6/1/99	Delete removing abandoned 6" water line	(\$500 00)
6/23/99	Add child proof inlet boxes	\$1,106 00
6/23/99	Galvanized loose lintels & paint galvanized spandrel beam lintels	\$1,414 00
6/23/99	Install 160' of 18" dia HDFE storm drains	\$2,664 00
7/20/99	Revise east parking area	\$774 00
7/20/99	Delete part of west parking area	(\$2,323 00)
8/18/99	Add door closers and ball-bearing hinges @ rooms #112, 113, 114 and 126	\$396 00

NET CHANGES TO DATE (\$2,741.00)

Sincerely,

Nelson I. Bass, Jr
President

NIB/kn



BASS CONSTRUCTION CO., INC.

3014 AVENUE I, SUITE 3 • ROSENBERG, TEXAS 77471 • 281-342-2022 • FAX 281-341-5071

Don A. Hartfiel AIA Architect
1000 Austin, Suite E
Richmond, Texas 77469

September 29, 1999

RE: FBC Pct 1 Community Center Testing Change Order

The testing performed by Aviles Engineering Corp in conjunction with the FBC Pct 1 Community Center Project has exceeded the allowance originally set aside and quoted in the original base bid

Original Allowance	\$ 3,500 00
Amount Billed	\$ 4,199 19
<i>Amount Exceeding Allowance</i>	<i>\$ 699 19</i>
<i>plus 5% P & O</i>	<i>\$ 34 96</i>
Change Order Total	734.15

Please contact our office to confirm that this change order has been accepted

sincerely,

A handwritten signature in black ink, appearing to read "Nelson I. Bass, Jr.", written in a cursive style.

Nelson I. Bass, Jr.
President

enclosure
nib/kn



BASS CONSTRUCTION CO., INC.

3014 AVENUE I, SUITE 3 • ROSENBERG, TEXAS 77471 • 281-342-2022 • FAX 281-341-5071

Don A. Hartfiel AIA Architect
1000 Austin, Suite E
Richmond, Texas 77469

September 27, 1999

RE: FBC Pct1 Community Center Construction Delay Days

1	Total Rain Days	_____	32 Days
2	Brck Procurement Delay	_____	60 Days
3	Pre-Engineered Steel Building Delay	_____	45 Days

Total Construction Days Delayed to date **137 Days**

Sincerely,

Nelson I. Bass, Jr.
President

nib/kn

FORT BEND COUNTY
COMMISSIONERS COURT AGENDA REQUEST FORM
 RETURN TO: AGENDA COORD.-COUNTY JUDGE'S OFFICE

DATE SUBMITTED: <u>10/06/99</u>	SUBMITTED BY: <u>M. Kindell</u>	AGENDA ITEM: <u>#18B</u>
COURT AGENDA DATE: <u>10/12/99</u>	DEPARTMENT: <u>Community Development</u>	
	PHONE NO.: <u>341-4410</u>	

SUMMARY OF ITEM: Increase in Contract Sum, Change Order No 2, \$40,349.40, Bass Construction Co., for construction of the Precinct 1 Community Center Building

Kitchen #124 Revision – Commercial appliances & sink	\$20,668 62
Platform #130 Ramp Addition	\$ 2,330 00
Card Entry System & Security System	\$17,350.78

Contract awarded to Bass Construction by Commissioners Court 3/2/99, FBC Bid #99-025 Project approved by Commissioners Court in the FY 1997 Consolidated Action Plan 7/8/97

RENEWAL CONTRACT/AGREEMENT: Yes () No (X)

LIST SUPPORTING DOCUMENTS ATTACHED: Change Order No 2, \$40,349 40

FINANCIAL SUMMARY:

BUDGETED ITEM:	ANNUALIZED DOLLARS:	COMMENTS
Yes (X) No () N/A ()	One Time ()	
Funding Source:	Recurring ()	
Fund <u>840</u> Agcy <u>101</u> Object <u>8040</u>	N/A ()	

Original Form Submitted with back up to County Judge's Office: Yes (X)

CC with back up:

yes (X) Auditor	(281-341-3774)	yes (X)	Comm. Pct. 1	(281-342-0587)
yes (X) Budget Officer	(281-344-3954)	yes (X)	Comm. Pct. 2	(281-403-8009)
yes (X) County Attorney	(281-341-4557)	yes (X)	Comm. Pct. 3	(281-242-9060)
yes (X) Purchasing Agent	(281-341-8642)	yes (X)	Comm. Pct. 4	(281-980-9077)

- Instructions for submitting an Agenda Request:**
1. Completely fill out agenda form, incomplete forms will not be processed
 2. Fax or inter-office copies of agenda form with all back up information by Wednesday at 2:00 p.m. to the departments listed above
 3. All original back-up must be received in the County Judges Office by 2.00 p.m. on Wednesday.

RECOMMENDATION / ACTION REQUESTED:

10-12-99 Originals sent to Hartfield + Bass from County Judges Office.

CHANGE ORDER

AIA DOCUMENT G701

OWNER
 ARCHITECT
 CONTRACTOR
 FIELD
 OTHER

PROJECT (name, address)	FORT BEND COUNTY PRECINCT 1 COMMUNITY CENTER 1330 BAND ROAD ROSENBERG, TEXAS	CHANGE ORDER NUMBER	TWO
TO CONTRACTOR (name, address)	BASS CONSTRUCTION CO. INC. 3014 AVENUE I, SUITE 3 ROSENBERG, TEXAS 77471	DATE	OCTOBER 6, 1999
		ARCHITECT'S PROJECT NO	
		CONTRACT DATE	MARCH 4, 1999
		CONTRACT FOR	FORT BEND COUNTY PCT. 1 COMMUNITY CENTER

The Contract is changed as follows

- ITEM #1 ADD \$20,668.62 - CHANGE KITCHEN 124 APPLIANCES AAND SINK TO COMMERCIAL TYPES - SEE ATTACHED SHEETS FOR CHANGES. CHANGE REQUESTED BY COUNTY.
 - ITEM #2 ADD \$17,350.78 - INSTALLATION OF A CARD ENTRY SYSTEM AND SECURITY SYSTEM FOR THE BUILDING - SEE ATTACHED SHEETS FOR SYSTEM PROPOSALS. CHANGE REQUESTED BY COUNTY.
 - ITEM #3 ADD \$2,330.00 - ADD RAMP TO PLATFORM 130 (STAGE AREA) - SEE ATTACHED SHEETS FOR RAMP. TEXAS ACCESSIBILITY REQUIREMENT.
- TOTAL ADD THIS CHANGE ORDER - \$40,349.40

Not valid until signed by the Owner, Architect and Contractor.

The original (Contract Sum) (Guaranteed Maximum Price) was	\$ 1,185,877.00
Net change by previously authorized Change Orders	\$ -2,007.00
The (Contract Sum) (Guaranteed Maximum Price) prior to this Change Order was	\$ 1,183,870.00
The (Contract Sum) (Guaranteed Maximum Price) will be (increased) (decreased) (unchanged) by this Change Order in the amount of	\$ 40,349.40
The new (Contract Sum) (Guaranteed Maximum Price) including this Change Order will be	\$ 1,224,219.40
The Contract Time will be (increased) (decreased) (unchanged) by	(-0-) days
The date of Substantial Completion as of the date of this Change Order therefore is	FEBRUARY 15, 2000

NOTE This summary does not reflect changes in the Contract Sum, Contract Time or Guaranteed Maximum Price which have been authorized by Construction Change Directive

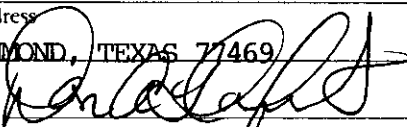
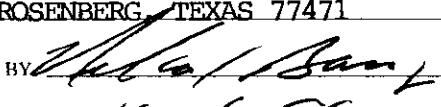
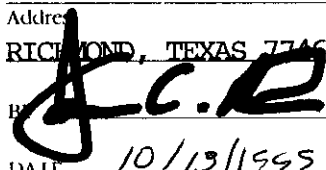
DON A. HARTFIEL AIA ARCHITECT	BASS CONSTRUCTION CO. INC.	FORT BEND COUNTY
ARCHITECT	CONTRACTOR	OWNER
1000 AUSTIN STREET	3014 AVENUE I, SUITE 3	309 S. 4th STREET
Address	Address	Address
RICHMOND, TEXAS 77469	ROSENBERG, TEXAS 77471	RICHMOND, TEXAS 77469
BY 	BY 	BY 
DATE 10/6/99	DATE 10-6-99	DATE 10/13/1999



BASS CONSTRUCTION CO., INC.

3014 AVENUE I, SUITE 3 • ROSENBERG, TEXAS 77471 • 281-342-2022 • FAX 281-341-5071

Don A. Hartfiel AIA Architect
1000 Austin, Suite E
Richmond, Texas 77469

September 27, 1999

RE: Pct 1 Community Center Proposed Changes

I. Proposed Kitchen # 124 Revision

1	Kitchen Equipment by Art Mart Supply	\$	16,994.65
2	Hood Installation by Accu Vent (only recommends vertical discharge)	\$	4,367 00
3	Hood State Inspection by Super Heat Air Balancing and Testing Co	\$	550 00
4	Structural Hood supports by Bass Construction	\$	492 00
5	Drywall furring above hood if required	\$	250 00
6	Painting	\$	150 00
7	Plumbing drain and supply	\$	185 00
8	Electrical	\$	1,100 00
9	Delete Cabinets	\$	(1,260 00)
10	Credit all previous appliances	\$	(2,669 00)
11	Appliances Installation labor	\$	1,130 00
12	Allowance for Refrigerator	\$	(2,500 00)
	<i>Net Additional Cost</i>	\$	18,789 65
	<i>Plus 10% P & O</i>	\$	1,878 97
	Total Additional Cost	\$	20,668.62

II. Proposed Platform # 130 Ramp Addition

1	Lumber Materials	\$	186 00
2	Misc Sheetrock and Acoustical work	\$	150 00
3	Carpentry Labor	\$	828 00
4	Steel rails	\$	323 00
5	Steel Labor	\$	190 00
6	Painting	\$	200 00
7	Electrical	\$	120 00
8	Carpet Ramp	\$	121 00
	<i>Net Additional Cost</i>	\$	2,118 00
	<i>Plus 10% P & O</i>	\$	212 00
	Total Additional Cost	\$	2,330.00

III. Proposed Card Entry System and Security System

1	All Materials & Labor by Reynold's Security	\$	16,404 55
2	Add two additional 110 electrical outlets	\$	120 00
	<i>Plus 5% P & O</i>	\$	826 23
	Total Additional Cost	\$	17,350.78



BASS CONSTRUCTION CO., INC.

3014 AVENUE I, SUITE 3 • ROSENBERG, TEXAS 77471 • 281-342-2022 • FAX 281-341-5071

Please contact our office immediately should you wish to implement any or all of these changes

Sincerely,

A handwritten signature in black ink, appearing to read "Nelson I. Bass, Jr.", written in a cursive style.

Nelson I. Bass, Jr.
President

mb/kn



BASS CONSTRUCTION CO., INC.

3014 AVENUE I, SUITE 3 • ROSENBERG, TEXAS 77471 • 281-342-2022 • FAX 281-341-5071

Don A. Hartfiel AIA Architect
1000 Austin, Suite E
Richmond, Texas 77469

Pct 1 Community Center Kitchen Appliances Breakdown

7' Commercial Hood with Ansul Fire System (includes exhaust fans)	\$ 5,095 00
roof curbs	\$ 120 00
loose collars	\$ 240 00
Refrigerator	\$ 2,075 00
Triple Sink Unit	\$ 725 00
Faucet for triple sink	\$ 94 95
Ice Maker	\$ 1,842 75
Ice Bin	\$ 702 00
Filter System for Ice Maker	\$ 199 95
Range	\$ 5,750 00
Delivery Charge	\$ 150 00

Appliances Selected by Architect Total **\$ 16,994.65**

Additional Appliances requested by Unknown person at County

Commercial Dishwasher (undercounter) with booster heater	\$ 3,595 00
10' long vent hood (will not fit in space)	\$ 5,995 00
Floor mounted undersink 35 gal grease trap	\$ 625 00

These are the prices as given to us by Ace Mart Supply

Sincerely,

Karen Noriega
Construction Assistant

QUOTATION

FROM



**H. G. REYNOLDS
SECURITY CENTERS, INC.**

207 Lane
ROSENBERG, TEXAS 77471

(281) 342-5328 342-6733

INQUIRY NO _____

DATE 8-05-99 _____

TERMS _____

DELIVERY _____

PRICES QUOTED ARE FOB
281-342-8557

TO Fort Bend County Pct.1 Community Center
c/o Don Hartfield

WE ARE PLEASED TO QUOTE ON YOUR INQUIRY AS FOLLOWS:

QUANTITY	DESCRIPTION	PRICE	AMOUNT
	Re: Alarm System		
1	Ademco Vista 40 Control Panel		\$ 300.00
2	Ademco 6139 Alpha Keypads	\$150.00ea	300.00
3	Motion Detectors(Hall, Lobby, Multi-use Room)	\$100.00ea	300.00
10	Exterior Doors		
	1- Single Door	35.00ea	35.00
	9- Double Doors	50.00ea	450.00
13	Point Identification Module	40.00ea	520.00
1	Inside Siren	50.00ea	50.00
	Wire & Misc. Materials		300.00
			\$2,255.00
	Tax Exempt		
	Optional Equipment:		
	7- Glass Break Detectors \$115.00each =		\$805.00
	1- Outside Siren with strobe - \$150.00		
	Monitoring Fee:		
	Basic Service \$25.00/month		
	Billed Quarterly		

QUOTED BY: H. G. Reynolds Security Centers, Inc.

Tx.Lic. #B-05496

QUOTATION

FROM  **H. G. REYNOLDS
SECURITY CENTERS, INC.**
207 Lane
ROSENBERG, TEXAS 77471

(281) 342-5328 342-6733

INQUIRY NO. _____

DATE August 3, 1999

TERMS _____

DELIVERY _____

PRICES QUOTED ARE FO B

TO Ft. Bend Senior Citizens
c/o Don Hartfield

WE ARE PLEASED TO QUOTE ON YOUR INQUIRY AS FOLLOWS

QUANTITY	DESCRIPTION	PRICE	AMOUNT
	Re: Proximity Card Access System		
1	HUBMAX Access Center		
6	Single Door Modifier		
6	Prox Card Readers		
6	Sentrol Contacts		
6	Surge Protectors		
6	PIR Request to Exit		
6	Mag Locks		
6	Red Exit Buttons		
	Wire & Connectors (Plenum)		
25	Cards (Prox)		
	Labor to install		\$13,244.55
	Tax Exempt		
	Customer will furnish dedicated P.C. IBM comp with Windows 95 - 98		
	All doors must have door closers		

QUOTED BY. H. G. Reynolds Security Centers, Inc. Tx.Lic. #B-05496

**FORT BEND COUNTY PREC
COMMUNITY CENTRE
PLATFORM 130 - RAMP ADDED**

PARTIAL FLOOR PLAN
1/8" = 1'-0"

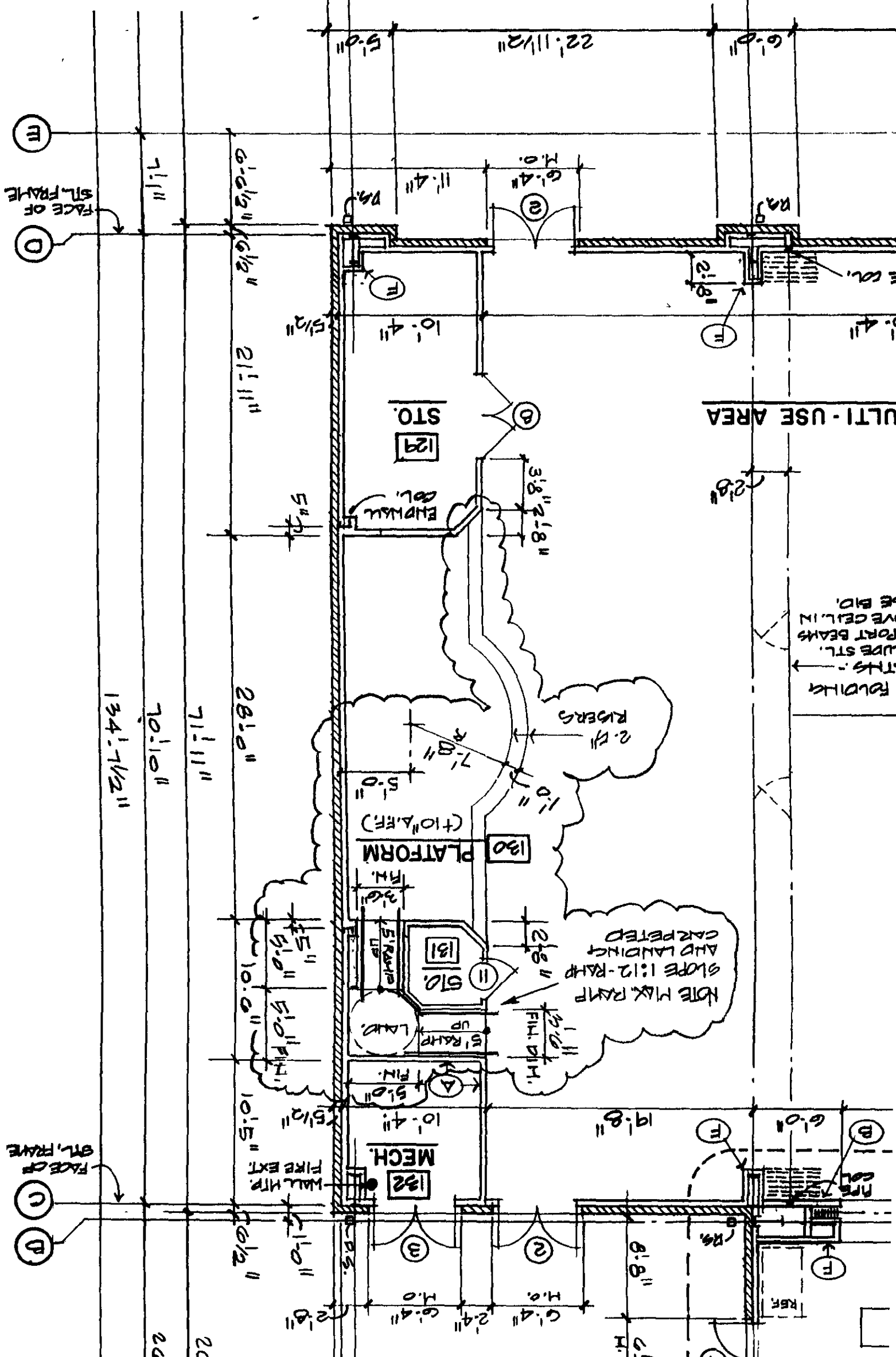

FOLDING STAIRS - W/ STEEL BEAMS OVER CEILING SEE BID.

NOTE MAX RAMP SLOPE 1:12 - RAMP AND LANDING CARPETED

PLATFORM (10' AREA)

MECH. UNIT

STO. 131

STO. 129

MULTI-USE AREA

STL. FRAME TYPICAL

FACE OF STL. FRAME

FACE OF STL. FRAME

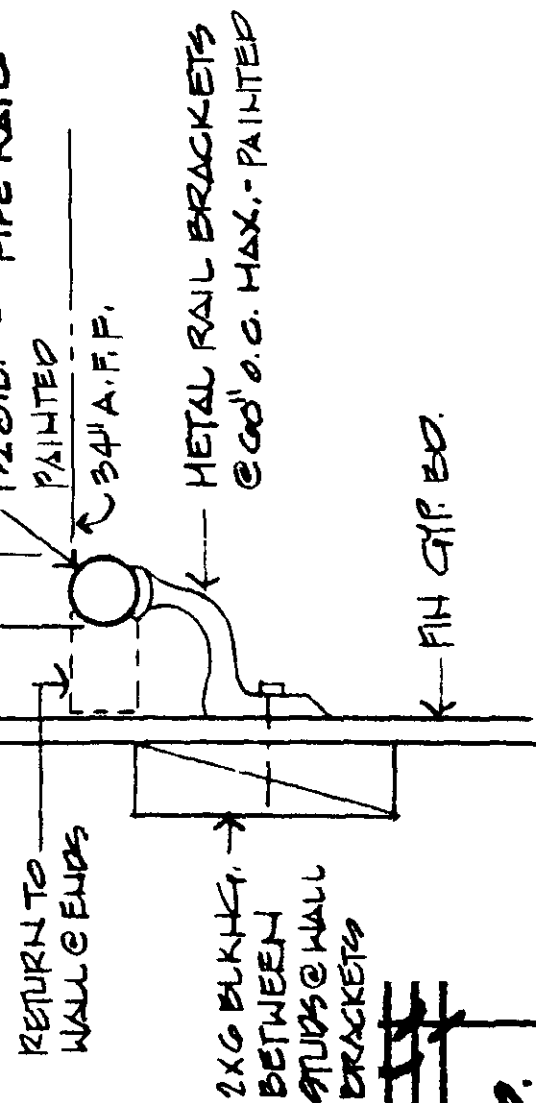

WALL HANDRAIL

3/4" = 1' 0" PLATFORM 130 RAMP

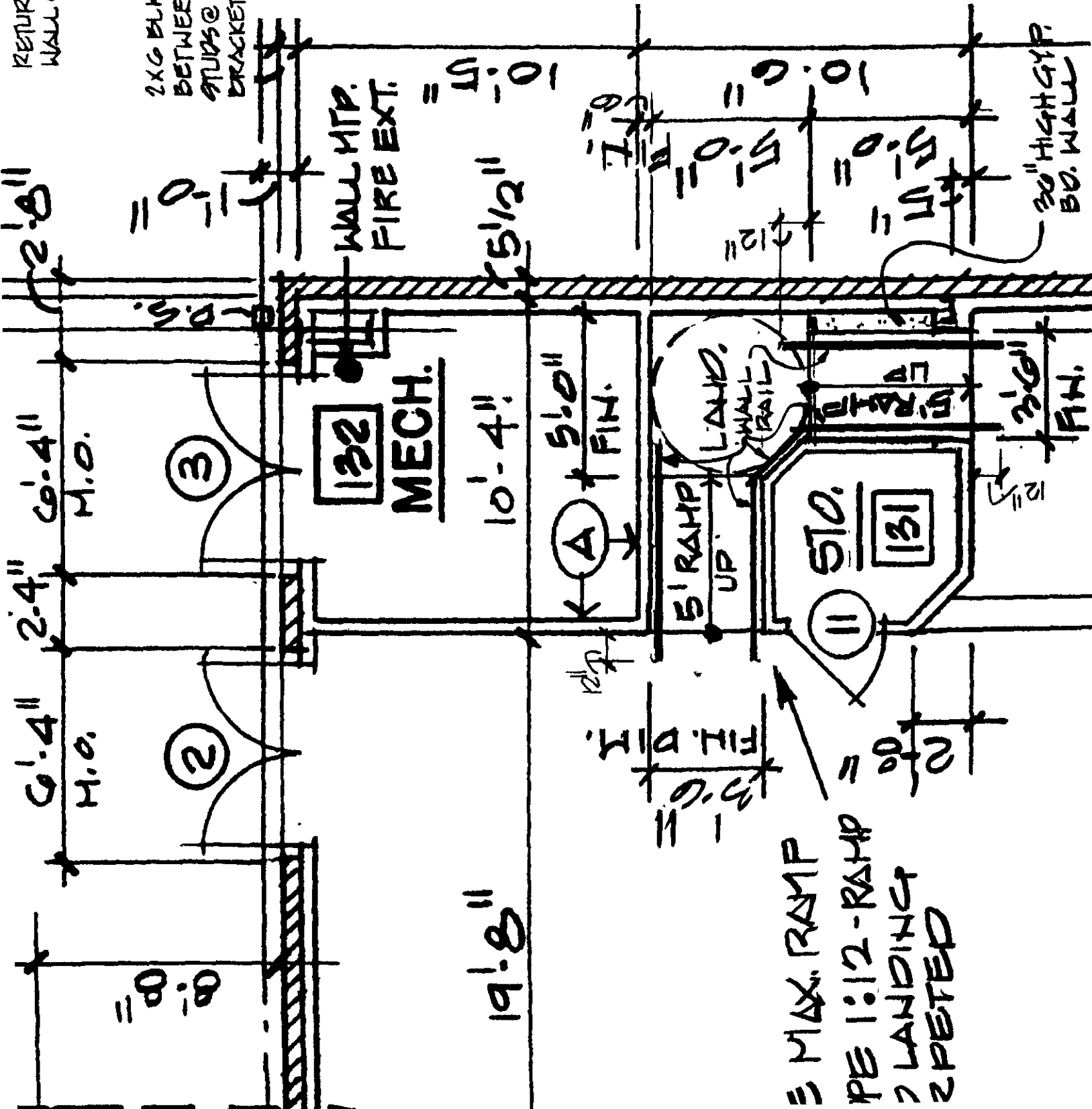

FORT BEND COUNTY PRECINCT 1
 COMMUNITY CENTER
 PLATFORM 130 - RAMP ADDED 9/8/99

MAX. RAMP
 1:12 - RAMP
 LANDING
 L.P.E.T.E.D.

FORT BEND COUNTY
COMMISSIONERS COURT AGENDA REQUEST FORM
 RETURN TO: AGENDA COORD.-COUNTY JUDGE'S OFFICE

DATE SUBMITTED. <u>10/06/99</u>	SUBMITTED BY: <u>Steve Raborn</u>	AGENDA ITEM #19
COURT AGENDA DATE: <u>10/12/99</u>	DEPARTMENT: <u>Elections Admin.</u>	
	PHONE NO.: <u>281-341-8670</u>	

SUMMARY OF ITEM:

Proposed split of voting precinct 3049 effective January 1, 2000.

RENEWAL CONTRACT/AGREEMENT: Yes () No

LIST SUPPORTING DOCUMENTS ATTACHED: Chart and maps with details of Options A, B, & C

FINANCIAL SUMMARY:

BUDGETED ITEM.	ANNUALIZED DOLLARS:	COMMENTS:
Yes () No () N/A <input checked="" type="checkbox"/>	One Time ()	
Funding Source: fund _____ agcy _____ Object _____	Recurring ()	
	N/A <input checked="" type="checkbox"/>	

Original Form Submitted with back up to County Judge's Office: Yes

CC with back up:

yes () Auditor	(281-341-3774)	yes <input checked="" type="checkbox"/> Comm. Pct. 1	(281-342-0587)
yes () Budget Officer	(281-344-3954)	yes <input checked="" type="checkbox"/> Comm. Pct. 2	(281-403-8009)
yes <input checked="" type="checkbox"/> County Attorney	(281-341-4557)	yes <input checked="" type="checkbox"/> Comm. Pct. 3	(281-242-9060)
yes () Purchasing Agent	(281-341-8642)	yes <input checked="" type="checkbox"/> Comm. Pct. 4	(281-980-9077)

- Instructions for submitting an Agenda Request:**
1. Completely fill out agenda form, incomplete forms will not be processed.
 2. Fax or inter-office copies of agenda form with all back up information by Wednesday at 2:00 p.m. to the departments listed above
 3. All original back-up must be received in the County Judges Office by 2:00 p.m. on Wednesday.

RECOMMENDATION / ACTION REQUESTED:

The Texas Election Code requires the County to divide voting precincts that have more than 3,000 active registered voters. As requested by the Court, I have provided several alternatives for dividing precinct 3049. Written descriptions of these proposals will be available by the October 12 meeting of Commissioners Court. I recommend Option "C".

Proposed Split of Voting Precinct 3049
Effective January 1, 2000

OPTION "A"

Proposed Precinct #	Proposed Polling Place	Address	Estimated number of active registered voters
3049	Brightwater Clubhouse	2410 Brightwater Drive	1,300
3127	Lexington Creek Elementary Sch	2335 Dulles Avenue	1,800

OPTION "B"

Proposed Precinct #	Proposed Polling Place	Address	Estimated number of active registered voters
3049	Brightwater Clubhouse	2410 Brightwater Drive	2,200
3127	Lexington Creek Elementary Sch	2335 Dulles Avenue	900

OPTION "C"

Proposed Precinct #	Proposed Polling Place	Address	Estimated number of active registered voters
3049	Brightwater Clubhouse	2410 Brightwater Drive	1,850
3127	Lexington Creek Elementary Sch	2335 Dulles Avenue	1,250

#20

FORT BEND COUNTY
COMMISSIONERS COURT AGENDA REQUEST FORM
RETURN TO: AGENDA COORD.-COUNTY JUDGE'S OFFICE

DATE SUBMITTED: 10/8/99
COMMISSIONERS COURT AGENDA FOR: 10/12/99

DEPT. SUBMITTED BY: County Attorney for Engineering
DEPT. PHONE NO. 281-341-4556

SUMMARY OF ITEM:

Discuss and consider approving Agreement between the State of Texas and Fort Bend County for proposed Park & Ride;
Discuss and consider adopting Resolution committing Fort Bend County funds of \$62,500 for Park & Ride project. Federal reimbursement is \$50,000.

RENEWAL CONTRACT/AGREEMENT: Yes () No (X)

LIST SUPPORTING DOCUMENTS ATTACHED: yes
(Back-up documentation must be attached for consideration)

FINANCIAL SUMMARY:

BUDGETED ITEM: Yes() No() N/A()	ANNUALIZED DOLLARS: One Time ()	COMMENTS
Funding Source: Fund _____ Agcy. _____ Object _____	Recurring ()	
	N/A ()	

Original form submitted with back up to County Judge's Office: Yes: (x)

CC with back up:

Auditor (281-341-3774)	Comm. Pct. 1 (281-344-0587)
Budget Officer (281-344-3954)	Comm. Pct. 2 (281-403-8009)
County Attorney (281-341-4557)	Comm. Pct. 3 (281-242-9060)
Purchasing Agent (281-341-8642)	Comm. Pct. 4 (281-980-9077) yes

Instructions for submitting an Agenda Request:

- 1 Completely fill out agenda form, incomplete forms will not be processed
- 2 Fax or inter-office copies of agenda form with all back-up information by Wednesday at 2 00 p m to the departments listed above
- 3 All original back-up must be received in the County Judge's Office by 2 00 p m on Wednesday

10-20-99 Original Agreements & Resolutions
 Sent to Engineering



COUNTY ATTORNEY
Fort Bend County, Texas

BEN W "Bud" CHILDERS
County Attorney

(281) 341-4555
Fax (281) 341-4557

October 7, 1999

The Honorable James C. Adolphus
County Judge
Fort Bend County

Re: SH 36 Fairgrounds Park and Ride Lot

Dear Judge Adolphus

This office has reviewed the proposed agreement between Fort Bend County and the State of Texas (Department of Transportation) regarding the Highway 36 Fairgrounds Park and Ride Lot. The Agreement authorizes a preliminary engineering study to determine the ridership and feasibility of such a lot. Upon execution of the Agreement the County must pay TxDot the amount of \$1000, which equals 20% of TxDot's estimated preliminary engineering review cost. The County will also retain a consultant to prepare the preliminary engineering, but will be reimbursed by the State for those costs.

The Agreement is approved as to legal form. Please place this matter on the next available agenda for consideration by Commissioners Court.

Very truly yours,

James Stavinoha, Assistant County Attorney

xc Commissioner R. L. O'Shieles, Precinct One
Commissioner Grady Prestage, Precinct Two
Commissioner Andy Meyers, Precinct Three
Commissioner James Patterson, Precinct Four
Jess Hegemier, County Engineer
Gilbert Jalomo, Purchasing Agent

/lj cover let 3569

3 569



Texas Department of Transportation

P O BOX 1386 • HOUSTON, TEXAS 77251-1386 • (713) 802-5000

September 21, 1999

CONTACT
CONSULTANT

Fort Bend County
CSJ 0188-01-031
VA SH 36 Fairgrounds Park and Ride Lot

Mr. Ron Drachenberg, P E
Assistant County Engineer
Fort Bend County Engineering Department
P O Box 1449
Rosenberg, Texas 77471-1449

Dear Mr Drachenberg

The subject project was selected for preliminary engineering funding only, under the 1998-2000 Transportation Improvement Program. Please find attached two original counterparts of a funding agreement for the subject project. We request that you review the agreement and provide us with any comments that you may have. If you have no comments, we request that you have the agreement executed on behalf of Fort Bend County (County) and that you return the agreement to us for execution by the State.

Please note that we will need a resolution passed by the Fort Bend County Commissioners Court committing County funds to the project. The resolution will be attached to the agreement as an Exhibit.

The following are the items that we feel would be required in the preliminary engineering for this project:

- 1 An environmental document for a finding of a Categorical Exclusion (CE)
- 2 A detailed ridership survey that indicates both present and future demand for the park and ride lot at the Fairgrounds location.

Mr Ron Drachenberg, P E
September 21, 1999
Page 2

- 3 A cost benefit analysis of the proposed park and ride lot that indicates why the project would be beneficial
- 4 An analysis of the air quality benefits of the project.
- 5 A site layout that indicates right of way metes and bounds, the number of parking spaces proposed, ingress and egress points, proposed structures, etc
- 6 A detailed cost estimate indicating how much the project will cost Please use Texas Department of Transportation (TxDOT) bid items if possible
- 7 Surveying of the right of way metes and bounds and topographical survey
- 8 Brief analysis of effect of project on area drainage and possible need for drainage mitigation.
- 9 A brief report containing the above items and which discusses the need for the project

If you want to receive Federal funding to reimburse you for consultant costs, you will have to meet Federal requirements for hiring a consultant. The County has an approved consultant selection procedure, which we implemented for the restoration of the Fort Bend County Courthouse A copy of this selection procedure is attached for your information

When you have selected a consultant, TxDOT will need to review and approve your contract with the consultant. Your contract will have to meet all Federal criteria We suggest that you use a standard TxDOT contract A copy of a sample contract is attached for your information along with a blank lump sum contract on a computer diskette The consultant will also be required to fill out a variety of Federal forms These forms are also on the diskette

We will require that the consultant contract contain the following information

1. A detailed project scope indicating the tasks which will be accomplished
- 2 An estimate by task of how much it will cost to perform each task

Mr Ron Drachenberg, P E
September 21, 1999
Page 3

- 3 The hourly wage rates for everyone who will charge to the project and everyone's job title
- 4 Overhead charges
- 5 Profit

Please contact Mr Mark D Patterson, P E at (713) 802-5506, should you have any questions concerning this matter

Sincerely,

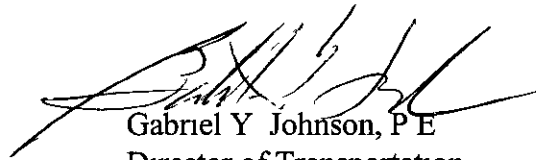

Gabriel Y Johnson, P E
Director of Transportation
Planning and Development
Houston District

MDP.sqd
Attachments

cc Mr Mark D Patterson, P E
Mr Alan Clark, Houston Galveston Area Council
Mr Jesse Hegemier, P E , Fort Bend County

THE STATE OF TEXAS §

THE COUNTY OF TRAVIS §

A G R E E M E N T

(CONGESTION MITIGATION AND AIR QUALITY)

THIS AGREEMENT, is made by and between the State of Texas, acting by and through the Texas Department of Transportation, hereinafter called the "State" and the County of Fort Bend, Texas, hereinafter called the "County"

W I T N E S S E T H

WHEREAS, the Intermodal Surface Transportation Efficiency Act of 1991, ("ISTEA") codified under Title 23 U S C Section 101 et seq, establishes the National Intermodal Transportation System that is economically efficient and environmentally sound, provides the foundation for the nation to compete in the global economy, and will move people and goods in an energy efficient manner; and

WHEREAS, Title 23 U S C Section 133 establishes that Surface Transportation Programs should be developed and implemented by the State's Transportation Agencies, and

WHEREAS, Title 23 U.S.C. Section 134 establishes that Metropolitan Planning Organizations ("MPO's") and the State's Transportation Agencies to develop transportation plans and programs for urbanized areas of the State; and

WHEREAS, the County is a member of the Houston-Galveston Area Council, a Metropolitan Planning Organization, chartered under the laws of Texas, and

WHEREAS, Title 23 U S C Section 149 establishes the Congestion Mitigation and Air Quality Improvement Program ("CMAQ") to contribute to attainment of the national ambient air quality standard to be implemented by the State's Transportation Agencies; and

WHEREAS, Houston is classified as a severe ozone non-attainment area, and the State must use funds in ozone and carbon monoxide non-attainment areas; and

WHEREAS, the State and the County desire to provide a Park and Ride Lot at the Fort Bend County Fairgrounds , as shown in "Exhibit A", to be hereinafter identified as the "Project", and

WHEREAS, Title 23 U.S.C. Section 120 establishes that the federal share of funding for Congestion Mitigation and Air Quality Programs will not exceed eighty percent (80%) of the Project cost; and

WHEREAS, the County has offered to participate in the development of the preliminary engineering in accordance with the Federal Highway Administration and the Texas Department of Transportation requirements, and

WHEREAS, on the 12th day of October, 1999, the Fort Bend County Commissioners Court passed Resolution No 20, attached hereto and identified as "Exhibit B", authorizing the County's participation in the development of the Project; and

WHEREAS, the State will secure the federal cost share, review the engineering, and provide other items as required; and

WHEREAS, the Project has been approved by the Federal Highway Administration and the Texas Transportation Commission for inclusion in the 1998-2000 Transportation Improvement Program, a page of which is attached hereto and identified as "Exhibit C "

A G R E E M E N T

NOW, THEREFORE, in consideration of the premises and of the mutual covenants and agreements of the parties hereto, to be by them respectively kept and performed as hereinafter set forth, it is agreed as follows

1. **CONTRACT PERIOD**

This agreement becomes effective upon final execution by the State and shall terminate upon completion of the Project or unless terminated or modified as hereinafter provided.

2. **SCOPE OF PROJECT**

The State and the County agree that the scope of the Project shall be limited to the scope authorized by the Texas Transportation Commission. The scope of the Project is to prepare the environmental assessment, right of way maps, property descriptions, schematic layout, perform field surveys, conduct public meetings/hearings, conduct ridership surveys and feasibility studies and any other work necessary to perform preliminary engineering.

3. **COUNTY RESPONSIBILITIES**

A The County will prepare or cause to be prepared the Project's preliminary engineering necessary for the development of the Project. Development of the preliminary engineering shall include, but not be limited to, preparing the environmental assessment, right of way mapping, schematic layout, performing field surveys, conducting public meetings/hearings, performing ridership surveys and feasibility studies

B The County shall provide to the State environmental reports to be submitted to the appropriate regulatory agency(s), providing documentation to the satisfaction of these regulatory agency(s) that the environmental problems have been remedied

C The County will prepare right of way maps, property descriptions and other data as needed to properly describe the right of way which the County is to acquire. The right of way maps and property descriptions shall be submitted to the State for approval prior to the County acquiring the necessary right of way. Tracings of the right of way maps shall be retained by the County for its permanent records

D The preliminary engineering shall be developed by a consultant selected by the County

in accordance with the latest edition and revisions of the State's Highway Design Division Operations and Procedures Manual or the American Association of State Highway and Transportation Official's A Policy on Geometric Design of Highways and Streets, the Texas Department of Transportation's 1993 Standard Specifications for Construction of Highways, Streets and Bridges, Federal regulations for conformity with the Clean Air Act air quality requirements, the EPA-National Pollutant Discharge Elimination System requirements, the Texas Accessibility Standards of the Architectural Barriers Act and the Texas Manual on Uniform Traffic Control Devices. In addition, all engineering work shall be prepared using the English system of measurements. Documents prepared for the purpose of public involvement shall be in the English unit system.

E. The Preliminary Engineering must include a ridership survey of the expected users of the proposed facility. The results of the survey will determine if a park and ride facility is justified at this location and whether or not funds will be allocated to construct the proposed facility. The ridership survey should include projections that evaluate both current demand and future demand for use of the facility over the next twenty years. In addition, the Preliminary Engineering Study must identify the air pollution benefits of the proposed facility.

F. The County must comply with applicable State and federal rules and procedures in selection of the consultant and the consultant selection procedure must have prior approval by the Texas Department of Transportation and the Federal Highway Administration. The County shall forward to the State a copy of the completed preliminary engineering for review.

4. STATE RESPONSIBILITIES

The State will review all preliminary engineering and process environmental documents.

5. FUNDING RESPONSIBILITIES

A. The total estimated costs associated with the preliminary engineering of the Project is \$62,500

B. The State will be responsible to secure the federal share of funding required for the preliminary engineering of the Project. The federal share for preliminary engineering of the Project is eighty percent (80%) of the total estimated eligible cost of preliminary engineering, not to exceed \$50,000. The County will be responsible for twenty percent (20%) of the total estimated cost of preliminary engineering, plus the State's Indirect Cost Recovery Plan. The County will also be responsible for any non-federal participation costs associated with the Project.

C. The estimated preliminary engineering review cost to be incurred by the Texas Department of Transportation is \$5,000. Upon execution of this agreement, the County will submit a check or warrant made payable to the "Texas Department of Transportation" in the amount of \$1,000, which amount is based on twenty percent (20%) of the estimated preliminary engineering review cost. These funds will be utilized by the State to review the engineering documentation, and cover other incidental costs.

D. The County shall make progress payments to the consultant and submit the completed preliminary engineering to the State for review and approval. The County shall retain and submit to the State all cost documentation associated with the development of the completed preliminary engineering.

E. The State shall reimburse the County funds which have been incurred and are applicable to the federal cost sharing arrangement established herein. The payments to the County for services rendered will be made monthly based upon the County's approved monthly progress report and itemized and certified statements (Texas Department of Transportation Form 132, or an invoice that is acceptable to the State) detailed to show the

the names of employees, time worked, actual work performed and actual rates. Monthly statements should include authorized non-salary expenses with supporting itemized invoices. The County shall comply with the cost principles established in OMB Circular A-87, "Cost Principles for State and Local Governments."

F. The itemized and certified statements shall show the total amount earned to the date of submission and the amount due and payable as of the date of the current statement. Final payment of any money due should be made to the County after satisfactory completion of all services and obligations covered in this contract, including acceptance of work by the State and completion of final audit. Final payment does not relieve the County of the responsibility of correcting any errors and/or omissions resulting from negligence.

G. The original Form 132, or an invoice that is acceptable to the State, and four (4) copies should be submitted directly to the District Office to expedite processing. Upon receipt and approval of each statement, the Department shall pay the amount which is due and payable within thirty (30) days.

H. The State will perform an audit of all costs associated with preliminary engineering. In the event additional funding is required by the County at anytime during the preliminary engineering, the County will provide the funds within thirty (30) days from receipt of the State's written notification. In the event any funds are due the County, the State will promptly make arrangements to provide the funds to the County.

6. INDIRECT COST RECOVERY PLAN

Section 2106, Texas Government Code, requires the State to recover indirect costs based on a percentage of the State's actual direct costs to complete the Project. The indirect costs will be in accordance with the State's Indirect Cost Recovery Plan and will be based on the County's funding percentage provided herein. The indirect cost ratio in effect for this project is zero.

7. OWNERSHIP OF DOCUMENTS

Upon completion or termination of this agreement, all documents prepared by the County shall remain the property of the County and all documents prepared by the State shall remain the property of the State. All data prepared under this agreement shall be made available to the State without restriction or limitation on their further use.

8. TERMINATION

A. This agreement may be terminated by any of the following conditions

(1) By mutual written agreement and consent of both parties.

(2) By either party, upon the failure of the other party to fulfill the obligation as set forth herein

B The termination of this agreement shall extinguish all rights, duties, obligations and liabilities of the State and County under this agreement. If the potential termination of this agreement is due to the failure of the County to fulfill its contractual obligations as set forth herein, the State will notify the County that possible breach of contract has occurred. The County should make every effort to remedy the breach as outlined by the State within a period mutually agreed upon by both parties

9. INDEMNIFICATION

To the extent permitted by law, the County shall indemnify and save harmless the State, its officers, employees, agents and contractors from all claims and liabilities due to the activities of the County, its officers, employees, agents and contractors performed under this agreement and which result from an error, omission or negligent acts of the County, its officers, employees, agents or contractors. Additionally, to the extent permitted by law, the County shall save harmless the State, its officers, employees, agents and contractors from any and all expenses, including attorneys fees and court costs which may be incurred by the State in litigation or otherwise resisting said claim or liabilities which might be imposed

on the State as the result of such activities by the County, its officers, employees, agents or contractors.

10. AMENDMENTS

Any changes in the time frame, character, agreement provisions or obligations of the parties hereto shall be enacted by written amendment executed by both the County and the State

11. LEGAL CONSTRUCTION

In case one or more of the provisions contained in this agreement shall for any reason be held invalid, illegal or unenforceable in any respect, such invalidity, illegality or unenforceability shall not affect any other provisions hereof and this agreement shall be construed as if such invalid, illegal or unenforceable provision had never been contained herein

12. NOTICES

All notices to either party by the other required under this agreement shall be delivered personally or sent by certified U S mail, postage prepaid, addressed to such party at the following respective addresses

State. Texas Department of Transportation
P O Box 1386
Houston, TX 77251-1386

or 7721 Washington Avenue
Houston, TX 77007

County The Office of the County Judge
Fort Bend County
Attn: Ron Drachenberg
~~P.O. Box 368~~
Richmond, Texas 77406-0368

All notices shall be deemed given on the date so delivered or so deposited in the mail, unless otherwise provided herein Either party hereto may change the above address by

sending written notice of such change to the other in the manner provided herein

13. SOLE AGREEMENT

This agreement constitutes the sole and only agreement between the parties hereto and supersedes any prior understandings or written or oral agreements respecting the within subject matter.

14. REMEDIES

Violation or breach of contract terms by the County shall be grounds for termination of the agreement, and any increased cost arising from the County's default, breach of contract, or violation of terms shall be paid by the County. This agreement shall not be considered as specifying the exclusive remedy for any default, but all remedies existing at law and in equity may be availed of by either party and shall be cumulative.

15. INSPECTION OF COUNTY'S BOOKS AND RECORDS

The State will, for purpose of termination of the agreement prior to completion, examine the books and records of the County for the purpose of checking the amount of the work performed by the County at the time of contract termination. The County shall maintain all books, documents, papers, accounting records and other documentation relating to costs incurred under this agreement and other documentation relating to costs incurred under this agreement and shall make such materials available to the State, Federal Highway Administration (FHWA) or its duly authorized representatives for four (4) years from the date of final payment under this contract or until impending litigation is resolved. Additionally, the State, FHWA, and its duly authorized representatives shall have access to all records of the County which are directly applicable to this agreement for the purpose of making audits, examinations, excerpts, and transcriptions.

16. OMB A-133 AUDIT REQUIREMENTS

The County shall comply with the requirements of the Single Audit Act of 1984 P L. 98-502, ensuring that the single audit report includes the coverage stipulated in paragraphs 6, 8, and 9 of OMB Circular No A-133.

17. PROCUREMENT STANDARDS

The County shall adhere to the procurement standards set forth in Title 49 CFR Part 18.36

18. PROPERTY MANAGEMENT STANDARDS

The County shall adhere to the property management standards set forth in Title 49 CFR Part 18 32

19. COMPLIANCE WITH LAWS

The County shall comply with all federal, State, and local laws, statutes, ordinances, rules and regulations, and the orders and decrees of any court, administration bodies, or tribunals in any matter affecting the performance of the agreement

20. CIVIL RIGHTS COMPLIANCE

The County shall comply with the regulations of the Department of Transportation as they relate to nondiscrimination (49 CFR 21 and 23 CFR 710 405 (B)), also Executive Order 11246 titled "Equal Employment Opportunity," as amended by Executive Order 11375 and as supplemented in the Department of Labor regulations (41 CFR 60)

21. MINORITY BUSINESS ENTERPRISE PROGRAM REQUIREMENTS

The County shall comply with the "Minonty Business Enterprise Program Requirements" established in 49 CFR Part 26

22. DEBARMENT CERTIFICATIONS

The County is prohibited from making any award at any tier to any party which is debarred or suspended or otherwise excluded from or ineligible for participation in federal assistance programs under Executive Order 12549, Debarment and Suspension. The County shall

require any party to a subcontract or purchase order awarded under this contract as specified in Title 49 of the Code of Federal Regulation, Part 29, (Debarment and Suspension) to certify its eligibility to receive federal funds and, when requested by the State, to furnish a copy of the certification.

23. SIGNATORY WARRANTY

The signatories to this agreement warrant that each has the authority to enter into this agreement on behalf of the entity they represent.

IN TESTIMONY HEREOF, the parties hereto have caused these presents to be executed in duplicate counterparts

THE COUNTY OF FORT BEND, TEXAS

By J.C.A.
James C. Adolphus
Typed Name

County Judge
Title

10-12-99
Date

ATTEST: [Signature]
County Clerk

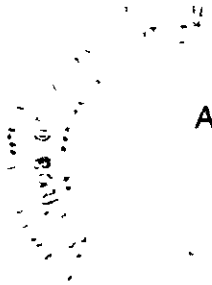

THE STATE OF TEXAS

Executed for the Executive Director and approved for the Texas Transportation Commission under the authority of Minute Order No 100002 and Administrative Circular 26-93 and superseded by Stand Alone Manual Notice 98-3, for the purpose and effect of activating and/or carrying out the orders, established policies or work programs heretofore approved by the Texas Transportation Commission

By _____

Lawrence J Zatopek
Director
General Services Division

Date

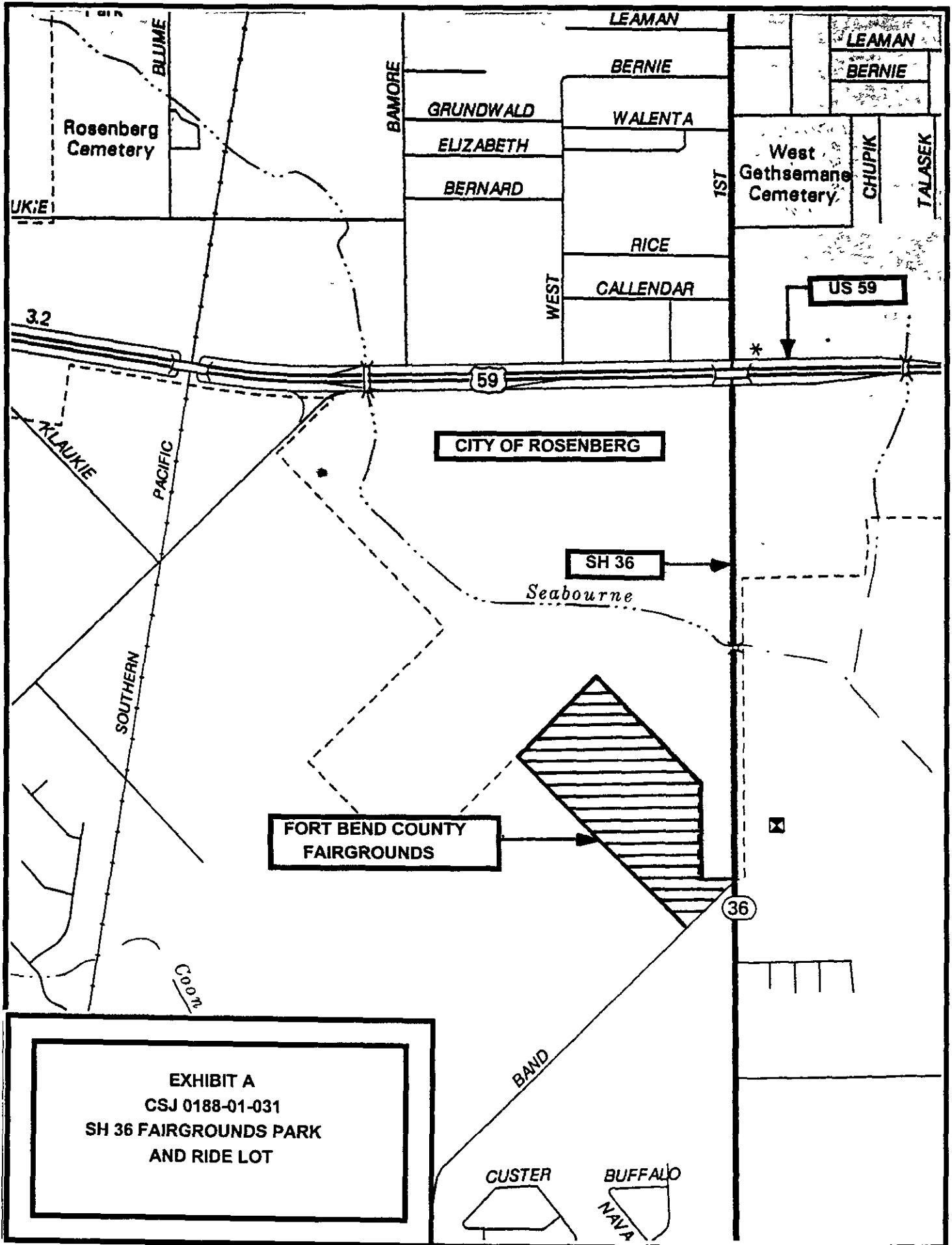

Rosenberg Cemetery

West Gethsemane Cemetery

CITY OF ROSENBERG

FORT BEND COUNTY FAIRGROUNDS

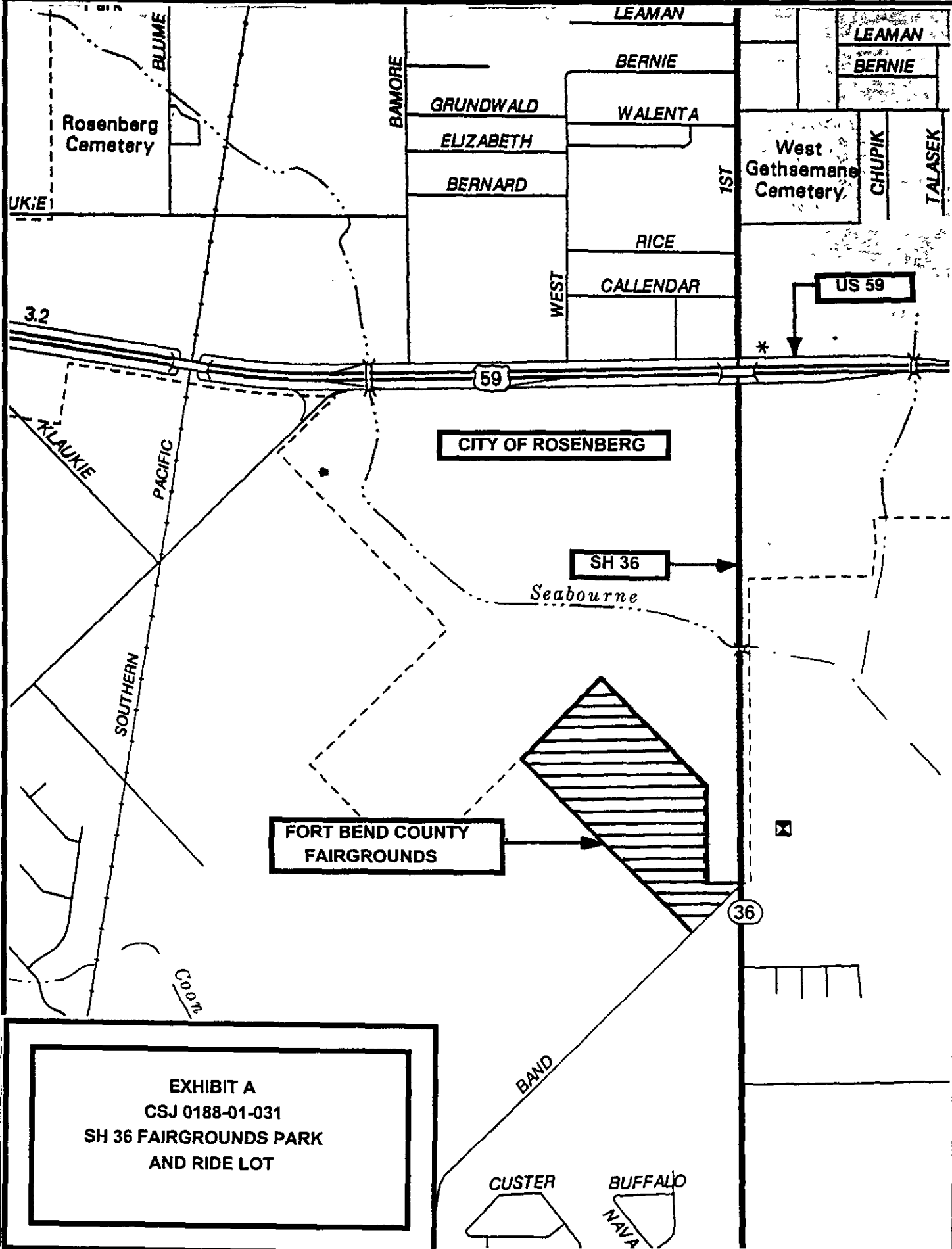
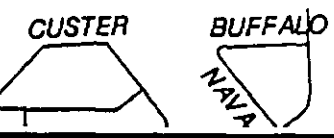

TRANSPORTATION IMPROVEMENT PROGRAM
HOUSTON DISTRICT
HOUSTON-GALVESTON MPO
1998

CSJ District County City	Name or Designation Location (From) Location (To) Description of Work Comments	APPN CAT 1	COST 1	Federal	Project ID Let Date Rvn Date Phase	
		APPN CAT 2	COST 2	State		
		APPN CAT 3	COST 3	Local		
		APPN CAT 4	COST 4	Local Contrib		
		Funding Category		Total		
0188-09-027 HOUSTON FORT BEND OTHER	FM 723 AT ATSF AND SP RAILROADS IN ROSENBERG RAILROAD GRADE SEPARATION AND APPROACHES	STP-RRX	\$2,200,000	\$1,760,001	950481	
		STP-RRX	\$1	\$440,000	98/08	
			\$0	\$0	09/1997	
		4G	STP-RR XING	\$0	\$0	C
				\$2,200,001		
0508-01-283 HOUSTON HARRIS OTHER	IH 10 SAN JACINTO ST MEADOW ST INSTALL COMPUTERIZED TRAFFIC MANAGEMENT SYST SPLIT FROM 0508-01-258	CMAQ	\$600,000	\$480,000	940266A	
			\$0	\$120,000	98/02	
			\$0	\$0	09/1997	
		5	CMAQ	\$0	\$0	C
				\$600,000		
0188-01-901 HOUSTON FORT BEND OTHER	SH 36 SH 36 - FAIRGROUNDS P&R @ US 59 PHASE I.FY 98 CONDUCT PE FOR FAIRGROUNDS PARK A MODIFIED HIGHWAY FROM VA TO SH 36 AND ASSIGNED	CMAQ	\$62,500	\$50,000	T96013A	
			\$0	\$0	98/08	
			\$0	\$12,500	12/1997	
		5	CMAQ	\$0	\$0	E
				\$62,500		
0188-01-902 HOUSTON FORT BEND OTHER	SH 36 US 59 US 90A CONSTRUCT PEDESTRIAN SIDEWALK ALONG SH 36	CMAQ	\$150,000	\$120,000	960727-XX	
			\$0	\$30,000	00/08	
			\$0	\$0	09/1997	
		5	CMAQ	\$0	\$0	C,E,R
				\$150,000		
0500-01-111 HOUSTON GALVESTON OTHER	IH 45 61ST ST S OF SH 6 INSTALL COMPUTERIZED TRANSPORTATION MANAGEM	CMAQ	\$3,856,000	\$3,084,800	950163	
			\$0	\$771,200	98/08	
			\$0	\$0	09/1997	
		5	CMAQ	\$0	\$0	C
				\$3,856,000	Carry Over	
0500-04-089 HOUSTON GALVESTON OTHER	IH 45 S OF SH 6 HARRIS CL INSTALL COMPUTERIZED TRANSPORTATION MANAGEM	CMAQ	\$10,345,000	\$8,276,000	950180	
			\$0	\$2,069,000	98/08	
			\$0	\$0	09/1997	
		5	CMAQ	\$0	\$0	C
				\$10,345,000		
0177-11-130 HOUSTON HARRIS OTHER	US 59 0.28 MI N OF SAUNDERS RD IH 610 INSTALL COMPUTERIZED TRANSPORTATION MANAGEM SPLIT OUT CSJ 0177-11-131	CMAQ	\$2,500,000	\$2,000,000	950164	
			\$0	\$580,000	98/01	
			\$0	\$0	09/1997	
		5	CMAQ	\$0	\$0	C
				\$2,500,000		
0389-06-083 HOUSTON GALVESTON OTHER	SH 146 @ EDGEWATER AND @ LP 197 N ADD RIGHT TURN LANES	CMAQ	\$243,672	\$194,937	960470-XX	
			\$0	\$48,734	98/08	
			\$0	\$0	09/1997	
		5	CMAQ	\$0	\$0	C
				\$243,672		

ESTIMATED COST BREAKDOWN

Fort Bend County
CSJ 0188-01-031
SH 36 Fairgrounds Park and Ride Lot

	<u>COUNTY</u>	<u>FEDERAL</u>	<u>TOTAL</u>
DESIGN COST * =	\$11,500.00	\$46,000.00	\$57,500 00
REVIEW COST =	\$1,000.00	\$4,000.00	\$5,000 00
TOTAL =	\$12,500.00	\$50,000.00	\$62,500.00

* ASSUMED COST

STATE OF TEXAS §

COUNTY OF FORT BEND §

RESOLUTION

On this the 12th day of October, 1999, the Commissioners Court, acting as the governing body of Fort Bend County, at a regular meeting upon motion of Commissioner Meyers, seconded by Commissioner Patterson, duly put and carried.

WHEREAS, Fort Bend County is a member of the Houston-Galveston Area Council, a Metropolitan Planning Organization ("MPO"), which is charged with developing transportation plans and programs for urbanized areas of the State, and,

WHEREAS, the State and County desire to provide a Park and Ride Lot at the Fort Bend County Fairgrounds, hereinafter referred to as the "Project", and,

WHEREAS, the County has offered to participate in the development of the preliminary engineering in accordance with the Federal Highway Administration and the Texas Department of Transportation requirements; and,

WHEREAS, the State of Texas will secure the federal cost share, review the engineering, and provide other items as required, and,

WHEREAS, the Project has been approved by the Federal Highway Administration and the Texas Transportation Commission for inclusion in the 1998-2000 Transportation Improvement Program, and,

WHEREAS, the County has available funds in the amount of \$62,500 to commit to the Project and is willing to commit such funds

NOW THEREFORE, BE RESOLVED AND DECREED by the Commissioners Court of Fort Bend County, Texas, that the Agreement with the State of Texas for preliminary engineering of a Park and Ride Lot at the Fort Bend County Fairgrounds is approved, and that County funds in the amount of \$62,500 are hereby committed to the Project.

PASSED AND APPROVED this 12th day of October, 1999

By J. C. R.
James C Adolphus, County Judge

ATTEST
Dianne Wilson
Dianne Wilson, County Clerk

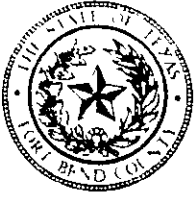

COUNTY PURCHASING AGENT

Fort Bend County, Texas

Gilbert D Jalomo, Jr , CPPB
County Purchasing Agent

(281) 341-8640
Fax (281) 341-8645

October 6, 1999

TO. Office of the County Judge
Fort Bend County, Texas

SUBJECT. Agenda Items Commissioners Court October 12, 1999

- 1 Authorize advertising for bids for the following:
 - a. Tires and tubes;
 - b. Photographic supplies,
 - c. Traffic signs/posts/supplies,
 - d. Oils and lubricants;
 - e. Weed, brush and insect control material
- 2 Authorize advertising for statements of qualification for engineering services for the park and ride at Fairgrounds
3. Consider taking action on Bid #99-079 Purchasing of pre-engineered building.
- 4 Consider renewing the term contract for hauling and disposal of condensate/leachate - Bid ~~#96-005~~. 99-001

cc with full package

Commissioner O'Shieles
Commissioner Prestage
Commissioner Meyers
Commissioner Patterson

Dianne Wilson
Robert Grayless
Jim Edwards
Bud Childers

cc cover only.

Dan Gerken - Drainage
Jess Hegemier

TABULATION

2/1/0

PURCHASE OF PRE-ENGINEERED BUILDING

BID #99-079

Company	BID PRICE
Whirlwind Steel Buildings, Inc Houston TX	\$50,979 00
NCI Building Systems Midwest Steel Building Company Houston TX	\$48,173.37

RECAPITULATION OF BID

Commissioners Court Approval	September 14 th
Legal Notice Advertised in Newspaper	September 19 th and 26 th
Individual Notices Mailed.	4
Bid Packets Picked Up or Mailed	4
Bid Opening Date	October 4 th
Bids Received	2

\$48,173.37

Funding: Drainage District 115-051-0510-1070



21D

September 29, 1999

Ms Debbie Kaminski
Fort Bend County
500 Liberty Street Suite 103
Richmond, Texas 77469

99-001

RE Fort Bend County Bid #~~96-005~~ - Term contract for hauling and disposal of condensate/leachate liquids from the Fort Bend County Landfill.

Magna-Flow Environmental agrees to renew the above stated contract, under the same terms and conditions Thank you for the opportunity to service your needs and we look forward to 2000

Sincerely,

Victor Sanchez
President

212

FORT BEND COUNTY
COMMISSIONERS COURT AGENDA REQUEST FORM
 RETURN TO AGENDA COORDINATOR - COUNTY JUDGE'S OFFICE

DATE SUBMITTED: 10/06/99 **DEPT. SUBMITTED BY:** Administrative Services
COMMISSIONERS COURT AGENDA FOR: 10/12/99 **DEPT. PHONE NO.:** 281/344-3950

SUMMARY OF ITEM:

Consider accepting this proposal for Architectural Services for the Rehabilitation Master Plan for the Fort Bend County Courthouse for an Historical grant application. Enclosed is a copy of that proposal.

RENEWAL CONTRACT / AGREEMENT: Yes () No (X)

LIST SUPPORTING DOCUMENTS ATTACHED: Proposal
 (Back-up documentation must be attached for consideration)

FINANCIAL SUMMARY:

BUDGETED ITEM:	ANNUALIZED DOLLARS:	COMMENTS:
Yes () No () N/A ()	One Time ()	
Funding Source:	Recurring ()	
Fund _____ Agcy. _____ Object _____	N/A ()	

Original Form Submitted with back up to County Judge's Office: Yes (X)

CC with back up:

Auditor	(281-341-3774) Yes (X)	Comm. Pct. 1	(281-344-0587) Yes (X)
Budget Officer	(281-344-3954) Yes (X)	Comm. Pct. 2	(281-403-8009) Yes (X)
County Attorney	(281-341-4557) Yes (X)	Comm. Pct. 3	(281-242-9060) Yes (X)
Purchasing Agent	(281-341-8642) Yes (X)	Comm. Pct. 4	(281-980-9077) Yes (X)

- Instructions for submitting an Agenda Request**
- 1 Completely fill out agenda form Incomplete forms will not be processed.
 - 2 Fax or inter-office copies of agenda form with all back up information by Wednesday, 2:00 p.m. to the departments listed above.
 - 3 All original back-up must be received in the County Judge's Office by 2.00 p.m., Wednesday

RECOMMENDATION / ACTION REQUESTED:

Recommended that this be accepted.

September 29, 1999

Mr. Tim Cumings
Fort Bend County
301 Jackson, Room 101
Richmond, Texas 77469

Tim, Merriman Holt Architects is pleased to present this proposal for Architectural Services for the Rehabilitation Master Plan for Fort Bend County Courthouse

For the purpose of this proposal, Merriman Holt Architects will be identified as MHA and Fort Bend County as the County

A **SCOPE OF SERVICES - BASIC ARCHITECTURAL SERVICES**

Following authorization to proceed, MHA will conduct an initial kickoff meeting with the County to set overall goals for the project. At that meeting we will establish a project schedule with major milestone dates.

Following the initial meeting, MHA will meet with the County and consultants. Our proposal is based on coordinating agency meetings to avoid multiple trips.

Our fee is based on the attached breakdown of hours designated to each task and documentation required to complete the Master Plan set forth by the Texas Historical Commission in the Texas Courthouse Preservation Program.

B **ADDITIONAL SERVICES**

Additional services shall include any work that is requested by the County beyond the scope of this proposal including professional inspections not included in this proposal. Additional services will require the County's written authorization and shall be billed at hourly rates as discussed in Section E.

C **CONSULTANT SERVICES**

The following services will be provided in this agreement:

Structural Review

A written review of the overall structural integrity of the Courthouse

I **AGREEMENT**

AIA Document B141-1997, "Standard Form of Agreement between Owner and Architect," will be the form of Agreement with modifications as agreeable to both parties. With your approval, we will prepare an agreement for your review.

Sincerely,



Dan Holt, AIA

Fort Bend County Courthouse Master Plan

Introduction

Executive Summary	4 hours
State of goals and purpose	3 hours
Methodology used for Master Plan Dev	2 hours
Identification of Master Plan Participants	3 hours

Historical and Architectural Dev.

List of previous Courthouse and Related Bldgs	4 hours	
Significant historical events	5 hours	(with assistance of owner)
Documentation for Historical buildings	10 hours	
List of later modifications	5 hours	
List of historic designations and deed covenants	5 hours	(with assistance of owner)

Evaluation of Existing Conditions

Evaluate the conditions on the site

Develop site plan	5 hours
Assesment of site conditions	20 hours

Evaluate building(s) conditions

Annotate floor plans and elevations	20 hours	
Assesment of building conditions	20 hours	
Evaluation of structural and MEP conditions	10 hours	(Coordinate w/ Eng)
Assesment of required analysis or testing	40 hours	
Evaluation of functional considerations	30 hours	
Evaluation of space use	10 hours	(put together info from PGAL)

Rehabilitation Recommendations

Summary of recommendations	10 hours	
Recommendations of building deficiencies	15 hours	(use part of PGAL package)
List of items requiring further analysis	5 hours	
Provide preliminary cost estimates	10 hours	
Develop a phased scope of work	10 hours	
Outline schedule for bldg Maintenance	20 hours	

Required Appendices

Bibliography	5 hours
Endnotes and bibliographic citations	2 hours
Commissioner's Court Minutes	Provided by Owner
Historic Photos and Plans	5 hours
Previous plans or studies of courthouse	Provided by Owner
Reports prepared by Consultants	See proposal
The Secretary of the Interior's Standards for Rehab	3 hours
Deed covenants	3 hours
Texas Government Code	2 hours
Texas Government Code (Recorded Texas Landmarks)	2 hours

Additional Hours

Meetings at Site	20 hours
Miscellaneous Research	30 hours
Field Measurement Site Visits	15 hours
Assembling Package	30 hours

Total Hours **383**

IN THE MATTER OF APPROVING BILLS FOR FORT BEND COUNTY FOR THE YEAR
1999

On this the 12th day of October, 1999 at a _____ Session

of the Commissioners Court with the following present

County Judge
Commissioner, Precinct 1
Commissioner, Precinct 2
Commissioner, Precinct 3
Commissioner, Precinct 4

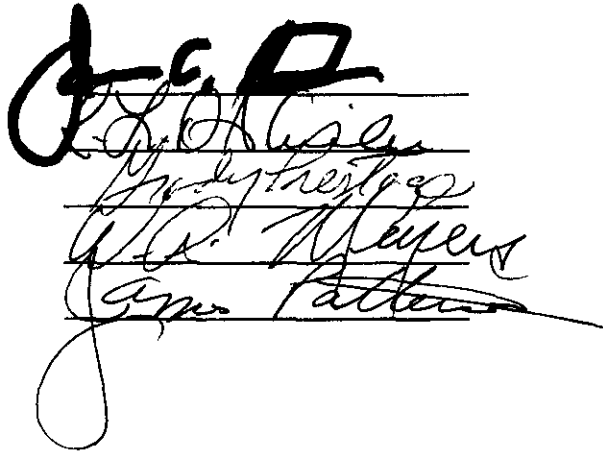

Now, therefore, be it resolved upon the motion of Commissioner Meyers
seconded by Commissioner Patterson, duly put and carried, it is ordered that
the bills be approved as presented by Robert Grayless, County Auditor

***** APPROVED *****

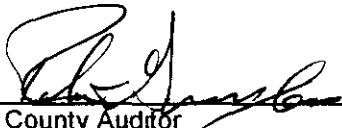
County Auditor

Date _____
Time Reconvened _____
Time Adjourned or Recessed _____

**FORT BEND COUNTY
COMMISSIONERS COURT AGENDA REQUEST FORM
RETURN TO: AGENDA COORD.-COUNTY JUDGE'S OFFICE**

PKwy #2

DATE SUBMITTED <u>Sept 28, 1999</u>	SUBMITTED BY: <u>Jim Edwards</u> <i>[Signature]</i>	AGENDA
COURT AGENDA DATE: <u>Oct 12, 1999</u>	DEPARTMENT: <u>Budget Office</u>	ITEM #
	PHONE NO.: <u>344-3937</u>	

SUMMARY OF ITEM:

Hold Public Hearing to discuss the 2000 Budget for the Fort Bend Parkway Association

RENEWAL CONTRACT/AGREEMENT: Yes () No ()

LIST SUPPORTING DOCUMENTS ATTACHED:
(Back-up documentation must be attached for consideration)

FINANCIAL SUMMARY:

BUDGETED ITEM:	ANNUALIZED DOLLARS:	COMMENTS:
Yes () No () N/A (<input checked="" type="checkbox"/>)	One Time ()	
Funding Source:	Recurring ()	
fund _____ agcy _____ Object _____		
N/A ()		

Original Form Submitted with back up to County Judge's Office: Yes ()

CC with back up:

Yes () Auditor	(281-341-3774)	Yes () Comm. Pct. 1	(281-344-0587)
Yes () Budget Officer	(281-344-3954)	Yes () Comm. Pct. 2	(281-403-8009)
Yes () County Attorney	(281-341-4557)	Yes () Comm. Pct. 3	(281-242-9060)
Yes () Purchasing Agent	(281-341-8642)	Yes () Comm. Pct. 4	(281-980-9077)

Instructions for submitting an Agenda Request:

1. Completely fill out agenda form, incomplete forms will not be processed.
2. Fax or inter-office copies of agenda form with all back up information by Wednesday at 2:00 p.m. to the departments listed above.
3. All original back-up must be received in the County Judges Office by 2:00 p.m. on Wednesday.

RECOMMENDATION / ACTION REQUESTED:

**FORT BEND COUNTY
COMMISSIONERS COURT AGENDA REQUEST FORM
RETURN TO: AGENDA COORD.-COUNTY JUDGE'S OFFICE**

PKwy # 3

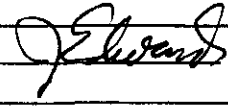
DATE SUBMITTED <u>Sept 28, 1999</u>	SUBMITTED BY: <u>Jim Edwards</u> 	AGENDA ITEM #
COURT AGENDA DATE: <u>Oct 12, 1999</u>	DEPARTMENT: <u>Budget Office</u>	
	PHONE NO.: <u>344-3937</u>	

SUMMARY OF ITEM:
Discuss and consider accepting the 2000 Proposed Budget for the Fort Bend Parkway Association

RENEWAL CONTRACT/AGREEMENT: Yes () No ()

LIST SUPPORTING DOCUMENTS ATTACHED:
(Back-up documentation must be attached for consideration)

FINANCIAL SUMMARY:

BUDGETED ITEM:	ANNUALIZED DOLLARS:	COMMENTS:
Yes () No () N/A (<input checked="" type="checkbox"/>)	One Time ()	
Funding Source: fund _____ agcy _____ Object _____ N/A ()	Recurring ()	

Original Form Submitted with back up to County Judge's Office: Yes ()

CC with back up:

Yes () Auditor	(281-341-3774)	Yes () Comm. Pct. 1	(281-344-0587)
Yes () Budget Officer	(281-344-3954)	Yes () Comm. Pct. 2	(281-403-8009)
Yes () County Attorney	(281-341-4557)	Yes () Comm. Pct. 3	(281-242-9060)
Yes () Purchasing Agent	(281-341-8642)	Yes () Comm. Pct. 4	(281-980-9077)

Instructions for submitting an Agenda Request:

1. Completely fill out agenda form, incomplete forms will not be processed.
2. Fax or inter-office copies of agenda form with all back up information by Wednesday at 2:00 p.m. to the departments listed above.
3. All original back-up must be received in the County Judges Office by 2:00 p.m. on Wednesday.

RECOMMENDATION / ACTION REQUESTED:

FORT BEND PARKWAY ROAD DISTRICT

BUDGET FINANCE SUMMARY

Beginning Balance 1/1/2000	\$ 196,500
Estimated Tax Revenue	\$118,029
Estimated Other Revenue	\$12,000
Estimated Total Revenue	\$130,029
2000 Proposed Budget	\$181,014
Estimated Change in Fund Balance	-\$50,985
Ending Fund Balance	\$145,515

AS PER ORIGINAL