

STATE OF TEXAS §
 §
 COUNTY OF FORT BEND §

ADDENDUM

This Addendum (“Addendum”) is made and entered into by and between FORT BEND COUNTY, TEXAS (“County”), a political subdivision of the state of Texas, and CENTERPOINT ENERGY HOUSTON ELECTRIC, LLC (“Utility”) a company authorized to conduct business in the state of Texas. County and Utility may be referred to individually as a “Party” or collectively as the “Parties.”

Terms

1. **Modification and Conflict.** This Addendum modifies and supplements the Facilities Extension Agreement between County and Utility (the “Agreement”), attached hereto as Exhibit “A” and incorporated by reference, for the extension of facilities at the following locations:
 - 12719 SIMONTON RD, WALLIS, TEXAS 77485
 - 3730 GERKEN RD, ROSENBERG, TEXAS 77471
 - 14643 BULS RD, EAST BERNARD, TEXAS 77435
 - 3721 FM 2919 RD, BEASLEY, TEXAS 77417
 - 14703 US HWY 59, BEASLEY, TEXAS 77417
 - 815 LUM RD, BEASLEY, TEXAS 77417

The Parties agree that if there is any conflict between this Addendum and the attached Agreement, the terms of this Addendum shall control.

2. **Compensation and Payment.** Any compensation and payment made by County for any services provided by Utility under the Agreement shall be made in accordance with Section 2251.021 of the Texas Government Code as follows: Utility shall submit to County one (1) electronic (pdf) copy of the invoice showing the amounts due for services performed in a form acceptable to County. County shall review such invoices and approve them within 30 calendar days with such modifications as are consistent with the Agreement and forward the same to the County Auditor for processing. County shall pay each such approved invoice within thirty (30) calendar days. Accrual and payment of interest on overdue payments assessed by Utility, if any, shall be governed by Section 2251.025 of the Texas Government Code.
3. **Limit of Appropriation.** Utility understands and agrees that the Maximum Compensation for the performance of services provided by Utility under the Agreement is Ten Thousand Six Hundred Sixty-Four and 00/100 dollars (\$10,664.00). In no event shall the amount paid by County under the Agreement exceed the Maximum Compensation without a County approved change order.
4. **Insurance.** Prior to the commencement of any services provided by Utility under the Agreement, Utility shall furnish County with properly executed certificates of

insurance which shall evidence all insurance required and provide that such insurance shall not be canceled, except on 30 days' prior written notice to County. Utility shall maintain such insurance coverage from the time Services commence until Services are completed and provided replacement certificates, policies, and/or endorsements for any such insurance expiring prior to completion of Services. Utility shall obtain such insurance written on an Occurrence form from such companies having Bests rating of A/VII or better, licensed or approved to transact business in the state of Texas, and shall obtain such insurance of the following types and minimum limits:

- (a) Workers' Compensation Insurance. Substitutes to genuine Workers' Compensation Insurance will not be allowed. Employers' Liability insurance with limits of not less than \$1,000,000 per injury by accident, \$1,000,000 per injury by disease, and \$1,000,000 per bodily injury by disease.
- (b) Commercial General Liability Insurance with a limit of not less than \$1,000,000 each occurrence and \$2,000,000 in the annual aggregate. Policy shall cover liability for bodily injury, personal injury, and property damage and products/completed operations arising out of the business operations of the policyholder.
- (c) Business Automobile Liability Insurance with a combined Bodily Injury/Property Damage limit of not less than \$1,000,000 each accident. The policy shall cover liability arising from the operation of licensed vehicles by policyholder.

County and the members of Commissioners Court shall be named as additional insured to all required coverage except for Workers' Compensation. All Liability policies including Workers' Compensation written on behalf of Utility shall contain a waiver of subrogation in favor of County and members of Commissioners Court.

If required coverage is written on a claims-made basis, Utility warrants that any retroactive date applicable to coverage under the policy precedes the effective date of the contract; and that continuous coverage will be maintained or an extended discovery period will be exercised for a period of two years beginning from the time that work under the Agreement is completed.

- 5. **No Waiver of Immunity.** Neither the execution of the Agreement nor any other conduct of either party relating to the Agreement shall be considered a waiver or surrender by County of its governmental powers or immunity under the Texas Constitution or the laws of the state of Texas.
- 6. **Venue and Applicable Law.** This Agreement shall be construed in accordance with the laws of the State of Texas and exclusive venue of any claim or legal action by Utility against County arising out of or relating to the subject matter of the Agreement shall lie in a court of competent jurisdiction of Fort Bend County, Texas.

7. **Certain State Law Requirements for Contracts** The contents of this Section are required by Texas law and are included by County regardless of content For purposes of Sections 2252.152, 2271.002, and 2274.002, Texas Government Code, as amended, Utility hereby verifies that Utility and any parent company, wholly owned subsidiary, majority-owned subsidiary, and affiliate:
- (a) Unless affirmatively declared by the United States government to be excluded from its federal sanctions regime relating to Sudan or Iran or any federal sanctions regime relating to a foreign terrorist organization, is not identified on a list prepared and maintained by the Texas Comptroller of Public Accounts under Section 806.051, 807.051, or 2252.153 of the Texas Government Code.
 - (b) If employing ten (10) or more full-time employees and the Agreement has a value of \$100,000.00 or more, Utility does not boycott Israel and is authorized to agree in such contracts not to boycott Israel during the term of such contracts. "Boycott Israel" has the meaning provided in § 808.001 of the Texas Government Code.
 - (c) If employing ten (10) or more full-time employees and the Agreement has a value of \$100,000.00 or more, Utility does not boycott energy companies and is authorized to agree in such contracts not to boycott energy companies during the term of such contracts. "Boycott energy company" has the meaning provided in § 809.001 of the Texas Government Code.
 - (d) If employing ten (10) or more full-time employees and the Agreement has a value of \$100,000.00 or more, Utility does not have a practice, policy, guidance, or directive that discriminates against a firearm entity or firearm trade association and is authorized to agree in such contracts not to discriminate against a firearm entity or firearm trade association during the term of such contracts. "Discriminate against a firearm entity or firearm trade association" has the meaning provided in § 2274.001(3) of the Texas Government Code. "Firearm entity" and "firearm trade association" have the meanings provided in § 2274.001(6) and (7) of the Texas Government Code.
8. **Human Trafficking.** BY ACCEPTANCE OF THE AGREEMENT, UTILITY ACKNOWLEDGES THAT COUNTY IS OPPOSED TO HUMAN TRAFFICKING AND THAT NO COUNTY FUNDS WILL BE USED IN SUPPORT OF SERVICES OR ACTIVITIES THAT VIOLATE HUMAN TRAFFICKING LAWS.
9. **Certification.** By his or her signature below, each signatory individual certifies that he or she is the properly authorized person or officer of the applicable Party hereto and has the requisite authority necessary to execute the Agreement on behalf of such Party, and each Party hereby certifies to the other that it has obtained the appropriate approvals or authorizations from its governing body as required by law.

{Execution Page Follows}

FORT BEND COUNTY

KP George
KP George, County Judge

January 8, 2026
Date

ATTEST:

Laura Richard
Laura Richard, County Clerk

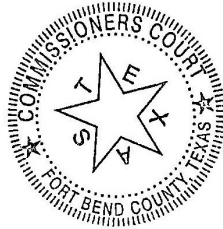

**CENTERPOINT ENERGY
HOUSTON ELECTRIC, LLC**

[Signature]
Authorized Agent - Signature

Gabriel Gonzalez
Authorized Agent- Printed Name

Manager
Title

12/26/25
Date

AUDITOR'S CERTIFICATE

I hereby certify that funds in the amount of \$ 10,664.00 are available to pay the obligation of Fort Bend County, Texas within the Agreement.

[Signature]
Robert Ed Sturdivant, County Auditor

i:\agreements\2026 agreements\facilities\centerpoint (26-fac-100361)\addendum for utilities facilities extension agreement (kcj - 12.3.2025) v2 12.19.2025

EXHIBIT A

(Follows Behind)



SERVICE OUTLET LOCATION AND DATA STATEMENT FOR ELECTRIC SERVICE

Page 1 of 7

Table with 2 columns: Field Name and Value. Fields include CUSTOMER (Fort Bend County), SERVICE ADDRESS (12719 Simonton Road), MAILING ADDRESS (301 Jackson Street), and ELECTRICIAN.

Dear Customer,

CenterPoint Energy Houston Electric, LLC is grateful to meet with you on, 09-12-2024 to discuss the requirements needed to provide you electric service.

Form with two columns of checkboxes. Left column: CenterPoint Energy Construction Required? YES, The following steps must be complete prior to construction: Pay any up-front contributions for non-standard service \$2,266.00, Clear trees along extension route, Easement charges, Easement execution. Right column: To begin the process we request that you provide the following information: Site Plan and Elevation Plan, Site Plan: Electronic Copy, One Line Diagram, Load Analysis, Easements Required, Specifications on Modular Metering Enclosure.

Form with two columns: YES, NO. Items include: Installation of meter pole or weather head, Obtain city or county permit, CenterPoint Energy will provide an ESI ID#, Choose a Competitive Retailer.

Want to start gas service? Go to move.centerpointenergy.com/move or call 800-752-8036 To learn more about energy efficiency programs, please visit centerpointefficiency.com

CenterPoint Energy Houston Electric, LLC's target completion date to provide your construction requirements, per the working sketch, is a mutually agreed upon negotiated date by CenterPoint Energy and customer. Please be aware our ability to meet the target completion date may be affected by weather, availability of construction crews and materials, ability to secure easements, and timely completion of your requirements (see above). In addition, as a condition to this service, you agree to comply with all of CenterPoint Energy standards, the National Electrical Code, the National Safety Code, all Occupational Safety and (OSHA) requirements, the International Building code and all local governing body codes.

We appreciate the opportunity to do business with you and look forward to the successful completion of this project. Your signature below insures that both parties understand the requirements toward completion that will allow you electrical service. Thanks for your cooperation in this matter.

Sincerely,

Service Consultant

Table with 2 columns: Field Name and Value. Fields include SERVICE CONSULTANT (Enrique Ramon, Gabriel Gonzalez), ADDRESS (935 Highway 90 ALT Rosenberg, Texas 77471), E-MAIL ADDRESS (enrique.ramon@centerpointenergy.com).

Table with 2 columns: Field Name and Value. Fields include CUSTOMER'S SIGNATURE (KP George), CUSTOMER'S PRINTED NAME (KP George), DATE (January 8, 2026).

Form with two columns: YES, NO. Items include: Will Customer have Back-up Generation?, Will Customer have Motor Greater than 250 HP?

Form titled APPLICABLE FORMS with checkboxes for: Power Quality, Primary Meter, Motor Start, Emergency Generation, Distributed Generation, Major UG Checklist.

<p align="center">GENERAL SERVICE</p> <input type="checkbox"/> 1Ø 3W 120/208 <input checked="" type="checkbox"/> 1Ø 3W 120/240 <input type="checkbox"/> 3Ø 4W Δ 240V <input type="checkbox"/> 3Ø 4W Y 120/208V <input type="checkbox"/> 3Ø 4W Y 277/480V* *10 X 26 PT can mounted on 480V Service? <input type="checkbox"/> 3Ø 3W Δ 480V* *1-1/4" conduit connecting CT & PT can run? <input type="checkbox"/> Primary Metering Job <input type="checkbox"/> Major UG Job <input type="checkbox"/> Other: (Explain) _____ _____		<p align="center">SERVICE TYPE</p> <p>_____ FT² <input checked="" type="checkbox"/> All Electric <input type="checkbox"/> Gas & Electric</p> <p>Size Wire Pulled _____</p> <p>Cust's Load 1 Ø <u>5</u> +3 Ø _____ = <u>5</u> Total KVA</p> <p>Fault Current: Initial <u>6,100</u> Ultimate <u>99,200</u></p> <p align="center">Amperes RMS Symmetrical at <u>240</u> Volts</p>	
<p align="center">CT CAN TYPE</p> <input type="checkbox"/> 320 Amp (self contained) <input type="checkbox"/> 30 X 42 <input type="checkbox"/> Bus Head Outdoor <input type="checkbox"/> Bus Head with CT Can <input type="checkbox"/> Stainless Steel Rack <input type="checkbox"/> Primary Job	<p align="center">CONDUITS ON POLE</p> <p align="center">Size of Conduit _____</p> <p align="center">No. of Conduits _____</p>	<p align="center">For Information Regarding:</p> <p align="center">CenterPoint Energy service standards visit www.centerpointenergy.com/electricservicestandards</p> <p align="center">For approvals on AUTOMATIC TRANSFER SWITCHES EMAIL SPECS TO ATS.Approvals@CenterPointEnergy.com</p>	

COMMENTS OR NOTES

Note: Customer may riser up existing Pole #1 or set Permanent Meter Pole as shown on sketch below.

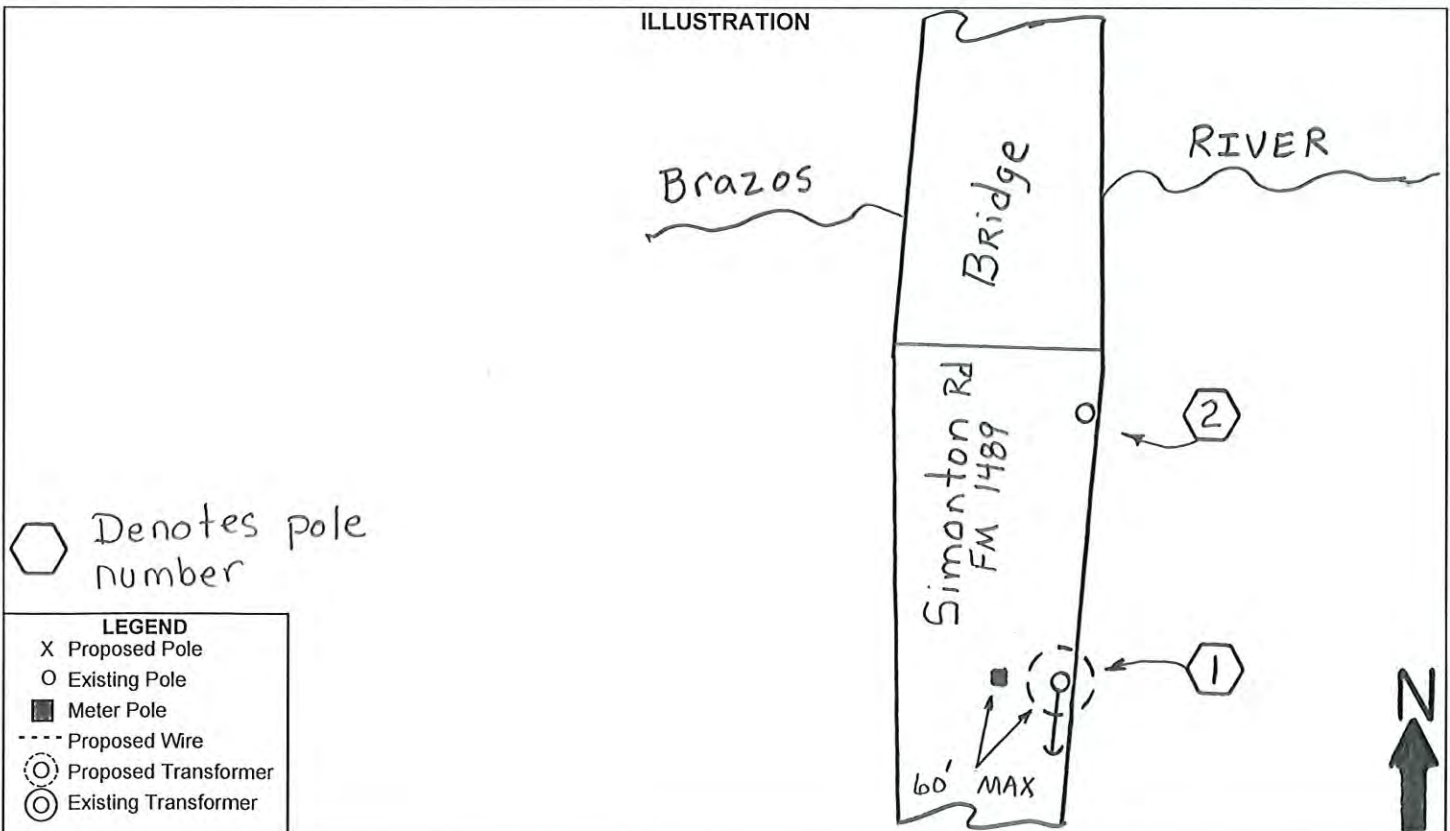

Taken from the CenterPoint Energy "Service Standards"

413 UNDERGROUND SERVICE LATERALS IN OVERHEAD AREAS

413.1 Requirements: It is necessary for Customers planning to install secondary underground service in Overhead Distribution Areas to consult the Service Consultant in the area to arrange for a Service Outlet Location and Data Statement as set forth in Article 203 and obtain the necessary Service Specifications for the installation. The Customer's underground riser conduit may be installed on CenterPoint Energy-poles where the pole is located on Customer's property or immediately adjacent in the street right-of-way or utility easement. Except for service transformer poles, customer riser conduit shall not be installed on poles with CenterPoint Energy power delivery equipment.

No more than four (4) conductors per phase and neutral shall be accepted per metered service (no more than 16 conductors per pole total for all services).

Customer's conduit installed on poles shall be only rigid metal, intermediate metal, or PVC Schedule 80. When the underground service entrance conduit is PVC and the riser on the pole is rigid or intermediate metal conduit, the Customer or Customer's contractor shall install Supply Side Bonding Jumpers for all risers in accordance with requirements of the National Electrical Code.

Customer's service riser may be installed on a service pole if located on the Customer's property. Service poles will be provided ONLY if the standard service extension requires them. If service poles are not required for standard service extension, the Customer shall install and maintain a separate pole for the underground riser. **The maximum conduit riser attached directly to a pole shall not exceed one 3" conduit.** Larger conduit and multiple conduits may be installed on poles of sufficient strength, but they must be installed on stand-off brackets (See Illustration 13 – Conduit risers on stand-off brackets, next page). For non-wood poles, stand-off brackets may be banded to the pole with a minimum 3/4" Stainless Steel Band. Alternatively for fiberglass or ductile iron poles, bolt holes may be drilled with a carbide hole saw or carbide drill bit no closer than 4" apart. Unused drilled holes shall be plugged or covered. When the Company's poles with approved customer equipment attached need to be relocated or replaced, the customer is responsible for relocating all their equipment at their cost within 30 days of receipt of written notification.

Taken from the CenterPoint Energy “Service Standards”

422 METER POLE INSTALLATIONS

422.1 Requirements: A meter pole is required in those cases where suitable location, clearance, and anchorage as called for in Articles 403, 404 and 406 are not available on the Customer's premises. Even if the conditions set forth in Articles 403, 404 and 406 are satisfied, the Customer has the option to install a meter pole. Meter poles are installed and maintained by the customer at his expense and shall not be installed in utility easements. Meter poles required by the Company or at the Customer's discretion shall be a minimum 6” diameter wood pole or a steel pole of equivalent strength. The use of alternate types of meter poles must have Company approval before installation. All meter poles shall provide the point of attachment, clearances, and anchorage as described herein. The pole setting depth shall be a minimum of 4 ft., or 2 ft. plus 10% of the pole length, whichever is greater. Steel poles shall be truck accessible. The Company will not provide service to any customer owned steel pole that is not truck accessible. The customer must provide a readily accessible Service Disconnect at the meter pole.

422.3 Meter Seals: It is the practice of the Company to seal or lock all meters. Only the Company's agents and persons authorized by law are permitted to remove a Company seal or lock.

**423 METER INSTALLATION SEQUENCE – 240V & BELOW
SELF-CONTAINED**

SERVICE – METER – SWITCH – FUSE – LOAD

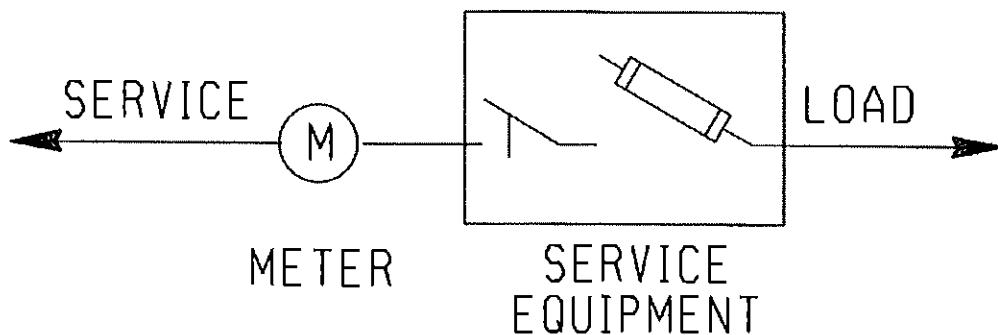

**TEXAS LAW AN ACT
TEXAS HEALTH AND SAFETY CODE TITLE 9**

CHAPTER 752 - Safety of persons engaged in activities in proximity of high voltage electric lines; restrictions

SECTION 001. DEFINITIONS

(1) "High voltage" means more than 600 volts measured between conductors or between a conductor and the ground.

(2) "Overhead line" means a bare or insulated electric conductor installed above ground but does not include a conductor that is de-energized and grounded or that is enclosed in a rigid metallic conduit.

SECTION 002. EXEMPTION FOR CERTAIN EMPLOYEES AND ACTIVITIES

(A) This chapter does not apply to the construction, reconstruction, operation, or maintenance by an authorized person of overhead electrical or communication circuits or conductors and their supporting structures and associated equipment that are part of a rail transportation system, an electrical generating, transmission, or distribution system or a communication system.

(B) In this section, "authorized person" means:

- (1) an employee of a light and power company, an electric cooperative, or a municipality working on his employer's electrical system;
- (2) an employee of a transportation system working on the system's electrical circuits;
- (3) an employee of a communication utility;
- (4) an employee of a state, county, or municipal agency that has authorized circuit construction on the poles or structures that belong to an electric power company, an electric cooperative, a municipal or transportation system, or a communication system;
- (5) an employee of an industrial plant who works on the plant's electrical system; or
- (6) an employee of an electrical or communications contractor who is working under the contractor's supervision.

SECTION 003. TEMPORARY CLEARANCE OF LINES

(A) A person, firm, corporation, or association responsible for temporary work or a temporary activity or function closer to a high voltage overhead line than the distances prescribed by this chapter must notify the operator of the line at least 48 hours before the work begins.

(B) A person, firm, corporation, or association may not begin the work, activity, or function under this section until the person, firm, corporation, or association responsible for the work, activity, or function and the owner or operator, or both, of the high voltage overhead line have negotiated a satisfactory mutual arrangement to provide temporary de-energization and grounding, temporary relocation or raising of the line, or temporary mechanical barriers to separate and prevent contact between the line and the material or equipment or the person performing the work, activity or function.

(C) The person, firm, corporation, or association responsible for the work, activity, or function shall pay the operator of the high voltage overhead line the actual expense incurred by the operator in providing the clearance prescribed in the agreement. The operator may require payment in advance and is not required to provide the clearance until the person, firm, corporation, or association responsible for the work, activity, or function makes the payment.

(D) If the actual expense of providing the clearance is less than the amount paid, the operator of the high voltage overhead line shall refund the surplus amount.

SECTION 004. RESTRICTION ON ALL ACTIVITIES NEAR LINES

(A) Unless a person, firm, corporation, or association effectively guards against danger by contact with the line as prescribed by Section 752.003, the person, firm, corporation, or association, either individually or through an agent or employee, may not perform a function or activity on land, a building, a highway, or other premises if at any time it is possible that the person performing the function or activity may:

- (1) move or be placed within six feet of a high voltage overhead line while performing the function or activity; or
- (2) bring any part of a tool, equipment, machine, or material within six feet of a high voltage overhead line while performing the function or activity.

(B) A person, firm, corporation, or association may not require an employee to perform a function or activity prohibited by Subsection (A).

SECTION 005. RESTRICTION ON OPERATION OF MACHINERY AND PLACEMENT OF STRUCTURES NEAR LINES

Unless a person, firm, corporation, or association effectively guards against danger by contact with the line as prescribed by Section 752.003, the person, firm, corporation, or association, either individually or through an agent or employee, may not:

- (1) erect, install, transport, or store all or any part of a house, building, or other structure within six feet of a high voltage overhead line;
- (2) install, operate, transport, handle, or store all or any part of a tool, machine, or equipment within six feet of a high voltage overhead line; or
- (3) transport, handle, or store all or any part of supplies or materials within six feet of a high voltage overhead line.

SECTION 006. RESTRICTION ON OPERATION OF CERTAIN MACHINERY OR EQUIPMENT

(A) A person, firm, corporation, or association, individually, through an agent or employee, or as an agent or employee, may not operate a crane, derrick, power shovel, drilling rig, hay loader, hay stacker, mechanical cotton picker, pile driver, hoisting equipment, or similar apparatus any part of which is capable of vertical, lateral, or swinging motion unless:

- (1) a warning sign is posted and maintained as prescribed by Subsections (B) and (C);
- (2) an insulated cage-type guard or protective device is installed about the boom or arm of the equipment, except a backhoe or dipper; and
- (3) each lifting line, if the equipment includes a lifting hook device, is equipped with an insulator link on the lift hook connection.

(B) The warning sign required by Subsection (A) (1) must be a weather-resistant sign of not less than five inches by seven inches with a yellow background and black lettering that reads: "WARNING -- UNLAWFUL TO OPERATE THIS EQUIPMENT WITHIN TEN FEET OF HIGH VOLTAGE LINES."

(C) The warning sign must be legible at 12 feet and placed:

- (1) within the equipment so that it is readily visible to the equipment operator while at the equipment controls; and
- (2) on the outside of the equipment in the number and location necessary to make it readily visible to a mechanic or other person engaged in the work.

(D) Notwithstanding the distance limitations prescribed by Sections 752.004 and 752.005, unless a person, firm, corporation, or association effectively guards against danger by contact with the line as prescribed by Section 752.003, the person, firm, corporation, or association may not operate all or any part of a machine or equipment described by this section within 10 feet of a high voltage overhead line.

SECTION 007. CRIMINAL PENALTY

(A) A person, firm, corporation, or association or an agent or employee of a person, firm, corporation, or association commits an offense if the person, firm, corporation, association, agent, or employee violates this chapter.

(B) An offense under this section is punishable by a fine of not less than \$100 or more than \$1,000, confinement in jail for not more than one year, or both.

SECTION 008. LIABILITY FOR DAMAGES

If a violation of this chapter results in physical or electrical contact with a high voltage overhead line, the person, firm, corporation, or association that committed the violation is liable to the owner or operator of the line for all damages to the facilities and for all liability that the owner or operator incurs as a result of the contact.

Acts 1989, 71st Leg., ch. 678, § 1, eff. Sept. 1, 1989

Prior Laws:

Acts 1971, 62nd Leg., p. 76, ch. 41.

Vernon's Ann. Civ. St. art. 1436c, § 7(B).

This is only a part of the entire act. The complete act is available for review.



**SERVICE OUTLET LOCATION AND DATA STATEMENT
FOR ELECTRIC SERVICE**

6 of 7

PERMITTING ENTITY	PHONE NUMBER	LIFE OF PERMIT	TYPE RES	TYPE GEN
City of Alvin	281-388-4271	No limit*	E/M	E
City of Arcola	281-431-0606	6 months	F	F
City of Bayou Vista	409-935-8348	No limit*	E	E
City of Baytown	281-420-6537	90 days	E/M	O
City of Beach City	281-383-3180	6 months	E	E
City of Beasley	979-387-2775	90 days	E	E
BRAZORIA COUNTY	979-864-1295	1 year	F	F
City of Bellaire	713-662-8230	90 days	E	E
City of Brookshire	281-375-5050	6 months	E	E
City of Brookside Village	281-485-3048	90 days	E/M	E
City of Bunker Hill	713-467-9762	No limit*	E	E
CHAMBERS COUNTY	409-267-8392	90 days	F	F
City of Clear Lake Shores	281-334-2799	6 months	E	E
City of Clute	409-265-2541	6 months	E	E
City of Cove	281-573-8309	1 year	E	E
City of Danbury	979-922-1551	1 year	E	E
City of Dayton	936-258-2642	6 months	E	E
City of Deer Park	281-478-7270	1 year	E	O
City of Dickinson	281-337-6259	30 days	E	E
City of El Lago	281-326-1951	1 year	E	E
City of Freeport	979-233-3526	6 months	E/F/M	E/F
FORT BEND COUNTY	281-633-7502	1 year	F	F
City of Friendswood	281-996-3200	No limit*	E	E
City of Fulshear	281-346-1796	6 months	E	E
City of Galena Park	713-672-2556	90 days	E	E
City of Galveston	409-797-3660	6 months	E	E
GALVESTON COUNTY	409-770-5549	6 months	F	F
HARRIS COUNTY	713-956-3000	1 year	F	F
City of Hedwig Village	713-465-6009	6 months	E	E
City of Hillcrest	281-756-0577	6 months	E	E
City of Hillshire Village	713-973-1779	No limit*	E	E
City of Hitchcock	409-986-5591	6 months	E	E
City of Houston	832-394-8847	6 months	E/M	E
City of Humble	281-446-3061	90 days	E/M	E/O
City of Hunters Creek	713-465-2150	No limit*	E	E
City of Iowa Colony	281-369-2471	90 days	E	E
City of Jacinto City	713-674-8424	90 days	E	E
City of Jamaica Beach	409-737-1142	1 year	E	E
City of Jersey Village	713-466-2110	1 year	E/M	E
City of Jones Creek	409-233-1826	90 days	E	E
City of Katy	281-391-4830	180 days	E	E
City of Kemah	281-334-1611	6 months	E/M	E
City of Lake Jackson	979-415-2430	180 days	E	O
City of La Marque	409-938-9204	6 months	E/M	E
City of La Porte	281-471-5020	6 months	E/M	O
City of League City	281-554-1415	90 days	E	E



**SERVICE OUTLET LOCATION AND DATA STATEMENT
FOR ELECTRIC SERVICE**

PERMITTING ENTITY	PHONE NUMBER	LIFE OF PERMIT	TYPE RES	TYPE GEN
City of Magnolia	281-356-2266	1 year	E	E
City of Manvel	281-489-0630	1 year	E/M	E
City of Meadows Place	281-983-2950	1 year	E/M	E
City of Missouri City	281-403-8600	90 days	O	O
City of Mont Belvieu	281-576-2213	90 days	O	O
MONTGOMERY COUNTY	936-539-7836	1 year	F	F
City of Morgan's Point	281-471-2171	6 months	E	E
City of Nassau Bay	281-333-2108	6 months	E	E
City of Needville	409-793-4253	90 days	E/M	E
City of Oak Ridge North	281-292-4648	6 months	E	E
City of Old River Winfree	281-385-1735	90 days	E	E
City of Orchard	979-478-6893	180 days	E/M	O
City of Oyster Creek	979-233-0243	6 months	E	E
City of Pasadena	713-477-1511	90 days	E/M	O
City of Pattison	281-375-5550	6 months	E	E
City of Pearland	281-652-1638	6 months	E/M	O
City of Piney Point Village	713-782-0271	90 days	E	E
City of Quintana	979-233-0848	90 days	E	E
City of Richmond	281-232-6871	6 months	E/M	O
City of Richwood	979-265-2082	90 days	E	E
City of Rosenberg	1-832-595-3400	90 days	E/M	O
City of Santa Fe	409-925-6412	6 months	E/M	E
City of Seabrook	281-291-5668	6 months	E	E
City of Sealy	979-885-1669	90 days	E/M	E
City of Shoreacres	281-471-2253	1 year	E	E
City of South Houston	713-947-7700	6 months	E/M	O
City of Southside Place	713-668-2341	90 days	E	E
City of Spring Valley	713-465-8308	6 months	E	E
City of Stafford	281-261-3940	6 months	E/M	O
City of Sugar Land	281-275-2270	6 months	E/M	O
Village of Surfside Beach	979-233-1531	6 months	E	E
City of Taylor Lake Village	281-326-2843	90 days	E	E
City of Texas City	409-643-5946	30 days	E/M	E
City of Tomball	281-351-5484	6 months	E/M	E
Village of Tiki Island	409-935-1427	1 year	E	E
City of Waller	936-931-1042	1 year	E	E
City of Webster	281-338-2925	90 days	E	O
City of West University Place	713-662-5833	1 year	E	E
City of Weston Lakes	281-533-0907	90 days	F	F
City of Wharton	979-532-2491	6 months	E	E

* Duration of project

CODE TYPES

- E= All new meter Installation and wiring changes.
- O= For all MVI and Name changes including Mobile Homes
- F= All new permanent and/or temporary service.
- M= Mobile Homes

CenterPoint Energy Houston Electric, LLC
Applicable: Entire Service Area

CNP 8038

6.3 AGREEMENTS AND FORMS

6.3.1 FACILITIES EXTENSION AGREEMENT

This Facilities Extension Agreement is entered into by and between _____
Fort Bend County _____, herein
called "Retail Customer" and CenterPoint Energy Houston Electric, LLC, herein called
"Company" (hereinafter referred to as Agreement) for the construction, extension, installation,
modification, repair, upgrade, conversion, relocation, de-energization or removal of Company's
Delivery System, including temporary facilities (hereinafter referred to as facilities extension or
extension), as described herein.

This Agreement covers the facilities extension to Retail Customer location at _____
12719 Simonton Road (FM 1489 at Brazos River) _____ **Layout #08**

The Company agrees to accept payment of _____ \$ 2,266.00 _____ Dollars
to be paid by the Retail Customer, as a Non-Refundable Construction Payment in connection
with the Retail Customer request to extend Company facilities to the above described location as
follows: _____ Permanent service beyond allowable distance. _____

_____ Cost to hang overhead transformer. _____

- Unless otherwise stated by Company in writing, the Non-Refundable Construction Payment amount above is valid for twelve months.

In consideration of said Non-Refundable Payment, to be paid to Company by Retail Customer prior to commencement of construction, Company agrees to install and operate lines and equipment necessary to distribute electric service to the identified location under the following General Conditions:

- Company shall at all times have title to and complete ownership and control over facilities installed by Company.
- Retail Customer must make satisfactory payment arrangements (if payment is required to extend Company facilities) and sign and return this Agreement before Company can proceed with the requested extension.

CenterPoint Energy Houston Electric, LLC
Applicable: Entire Service Area

CNP 8038

- Extension of service facilities is contingent on acquisition of all necessary easements and rights of way.

Nothing herein contained within this Agreement shall be construed as a waiver or relinquishment by Company of any right that it has or may hereafter have to discontinue service for or on account of default in the payment of any bill owing or to become owing thereafter for any other reason or cause stated in Company's Tariff.

This Agreement shall not be binding upon Company unless and until it is signed by an authorized representative of the Company.

CenterPoint Energy Houston Electric, LLC

Fort Bend County
Retail Customer

By Gabriel Gonzalez

By KP George

Gabriel Gonzalez
(name printed or typed)

KP George
(name printed or typed)

Title Service Area Manager

Title Fort Bend County Judge

Date 12/29/2025

Date January 8, 2026



Please make check payable to:
CenterPoint Energy

Attn: FTB SDAC

For FedEx/UPS: 935 Highway 90 ALT, Rosenberg, Tx 77471

For USPS: 935 Highway 90 ALT, Rosenberg, Tx 77471

INVOICE

Customer Info:

2/14/25

Name:	Fort Bend County				
Address:	12719 Simonton Road - (FM 1489 at Brazos River) Layout #08				
City:	Wallis	State:	TX	Zip	77485
Phone:	281-238-3565				
Email:	Isabel.Roberts@fortbendcountytexas.gov				
CNP Representative:	Enrique Ramon	Phone:	281-341-4931		

Description		W/O #	Total
1	Permanent service beyond allowable distance	113634683	\$ 2,266.00
2			
3			
4			
5			
			\$2,266.00

**PLEASE MAIL PAYMENT TO THE ABOVE ADDRESS.
Processing of check may be delayed without the return of this invoice.**

Make all checks payable to: *CenterPoint Energy*

Please send a copy of this invoice along with the check. Charges good for 1 year from date of invoice.

Payment is required prior to release of construction work order

If you have any questions concerning this invoice, please contact your CNP Representative at number above.

Thank you for using CenterPoint Energy



**SERVICE OUTLET LOCATION AND DATA STATEMENT
FOR ELECTRIC SERVICE**

Page 1 of 7

CUSTOMER Fort Bend County	DAY PHONE (281) 238-3565
SERVICE ADDRESS 3730 Gerken Road (Spur 10 at Cottonwood Creek)	EVENING PHONE (281) 642-5686
MAILING ADDRESS 301 Jackson Street Richmond, Tx 77469	CELL PHONE (281) 642-5686
ELECTRICIAN	ELECTRICIAN'S PHONE

Dear Customer,

CenterPoint Energy Houston Electric, LLC is grateful to meet with you on, 09-10-2024 to discuss the requirements needed to provide you electric service. DATE

<ul style="list-style-type: none"> • CenterPoint Energy Construction Required? <input checked="" type="checkbox"/> YES <input type="checkbox"/> NO • The following steps must be complete prior to construction: <ul style="list-style-type: none"> <input checked="" type="checkbox"/> Pay any up-front contributions for non-standard service \$ 1,674.00 <input type="checkbox"/> Clear trees along extension route <input type="checkbox"/> Easement charges \$ _____ <input type="checkbox"/> Easement execution 	<p>To begin the process we request that you provide the following information:</p> <ul style="list-style-type: none"> <input type="checkbox"/> Site Plan and Elevation Plan: Hard Copies <input type="checkbox"/> Site Plan: Electronic Copy with XY Coordinates <input type="checkbox"/> One Line Diagram <input type="checkbox"/> Load Analysis <input type="checkbox"/> Easements Required-Recorded Warranty Deed Required <input type="checkbox"/> Specifications on Modular Metering Enclosure.
--	--

<table> <tr> <td>YES</td> <td>NO</td> <td></td> </tr> <tr> <td><input checked="" type="checkbox"/></td> <td><input type="checkbox"/></td> <td>Installation of meter pole or weather head (as located on sketch).</td> </tr> <tr> <td><input checked="" type="checkbox"/></td> <td><input type="checkbox"/></td> <td>Obtain city or county permit, if applicable. (See page 4 and 5)</td> </tr> <tr> <td><input checked="" type="checkbox"/></td> <td><input type="checkbox"/></td> <td>CenterPoint Energy will provide an ESI ID# for your account to the email address provided as your project progresses. Please do not request a meter until the construction is completed.</td> </tr> <tr> <td><input checked="" type="checkbox"/></td> <td><input type="checkbox"/></td> <td>Choose a Competitive Retailer - For listing, visit the website http://www.powertochoose.org or call 1-866-PWR-4-TEX (1-866-797-4839)</td> </tr> </table>	YES	NO		<input checked="" type="checkbox"/>	<input type="checkbox"/>	Installation of meter pole or weather head (as located on sketch).	<input checked="" type="checkbox"/>	<input type="checkbox"/>	Obtain city or county permit, if applicable. (See page 4 and 5)	<input checked="" type="checkbox"/>	<input type="checkbox"/>	CenterPoint Energy will provide an ESI ID# for your account to the email address provided as your project progresses. Please do not request a meter until the construction is completed.	<input checked="" type="checkbox"/>	<input type="checkbox"/>	Choose a Competitive Retailer - For listing, visit the website http://www.powertochoose.org or call 1-866-PWR-4-TEX (1-866-797-4839)
YES	NO														
<input checked="" type="checkbox"/>	<input type="checkbox"/>	Installation of meter pole or weather head (as located on sketch).													
<input checked="" type="checkbox"/>	<input type="checkbox"/>	Obtain city or county permit, if applicable. (See page 4 and 5)													
<input checked="" type="checkbox"/>	<input type="checkbox"/>	CenterPoint Energy will provide an ESI ID# for your account to the email address provided as your project progresses. Please do not request a meter until the construction is completed.													
<input checked="" type="checkbox"/>	<input type="checkbox"/>	Choose a Competitive Retailer - For listing, visit the website http://www.powertochoose.org or call 1-866-PWR-4-TEX (1-866-797-4839)													

Want to start gas service? Go to move.centerpointenergy.com/move or call 800-752-8036
To learn more about energy efficiency programs, please visit centerpointefficiency.com

CenterPoint Energy Houston Electric, LLC's target completion date to provide your construction requirements, per the working sketch, is a mutually agreed upon negotiated date by CenterPoint Energy and customer. *Please be aware our ability to meet the target completion date may be affected by weather, availability of construction crews and materials, ability to secure easements, and timely completion of your requirements (see above). In addition, as a condition to this service, you agree to comply with all of CenterPoint Energy standards, the National Electrical Code, the National Safety Code, all Occupational Safety and (OSHA) requirements, the International Building code and all local governing body codes.*

We appreciate the opportunity to do business with you and look forward to the successful completion of this project. Your signature below insures that both parties understand the requirements toward completion that will allow you electrical service. Thanks for your cooperation in this matter.

Sincerely,

Service Consultant

SERVICE CONSULTANT Enrique Ramon <i>Gabriel Gonzalez</i>	PHONE NUMBER (281) 341-4931
ADDRESS 935 Highway 90 ALT Rosenberg, Texas 77471	
E-MAIL ADDRESS enrique.ramon@centerpointenergy.com	

CUSTOMER'S SIGNATURE <i>KP George</i>	DATE January 12, 2026
CUSTOMER'S PRINTED NAME KP George	

YES	NO	
<input type="checkbox"/>	<input checked="" type="checkbox"/>	Will Customer have Back-up Generation?
<input type="checkbox"/>	<input checked="" type="checkbox"/>	Will Customer have Motor Greater than 250 HP?

APPLICABLE FORMS	
<input type="checkbox"/>	Power Quality
<input type="checkbox"/>	Primary Meter
<input type="checkbox"/>	Motor Start
<input type="checkbox"/>	Emergency Generation
<input type="checkbox"/>	Distributed Generation
<input type="checkbox"/>	Major UG Checklist

20F7

<p align="center">GENERAL SERVICE</p> <p><input type="checkbox"/> 1Ø 3W 120/208</p> <p><input checked="" type="checkbox"/> 1Ø 3W 120/240</p> <p><input type="checkbox"/> 3Ø 4W Δ 240V</p> <p><input type="checkbox"/> 3Ø 4W Y 120/208V</p> <p><input type="checkbox"/> 3Ø 4W Y 277/480V* *10 X 26 PT can mounted on 480V Service?</p> <p><input type="checkbox"/> 3Ø 3W Δ 480V* *1-1/4" conduit connecting CT & PT can run?</p> <p><input type="checkbox"/> Primary Metering Job</p> <p><input type="checkbox"/> Major UG Job</p> <p><input type="checkbox"/> Other: (Explain) _____</p>	<p align="center">SERVICE TYPE</p> <p>_____ FT² <input checked="" type="checkbox"/> All Electric <input type="checkbox"/> Gas & Electric</p> <p>Size Wire Pulled _____</p> <p>Cust's Load 1 Ø <u>5</u> +3 Ø _____ = <u>5</u> Total KVA</p> <p>Fault Current: Initial <u>6,100</u> Ultimate <u>99,200</u></p> <p align="center">Amperes RMS Symmetrical at <u>240</u> Volts</p>
---	---

<p align="center">CT CAN TYPE</p> <p><input type="checkbox"/> 320 Amp (self contained)</p> <p><input type="checkbox"/> 30 X 42</p> <p><input type="checkbox"/> Bus Head Outdoor</p> <p><input type="checkbox"/> Bus Head with CT Can</p> <p><input type="checkbox"/> Stainless Steel Rack</p> <p><input type="checkbox"/> Primary Job</p>	<p align="center">CONDUITS ON POLE</p> <p align="center">Size of Conduit _____</p> <p align="center">No. of Conduits _____</p>	<p align="center">For Information Regarding:</p> <p align="center">CenterPoint Energy service standards visit www.centerpointenergy.com/electricservicestandards</p> <p align="center">For approvals on AUTOMATIC TRANSFER SWITCHES EMAIL SPECS TO ATS.Approvals@CenterPointEnergy.com</p>
--	---	--

COMMENTS OR NOTES

Note: Customer may riser up existing Pole #1 or set Permanent meter Pole as shown on sketch.

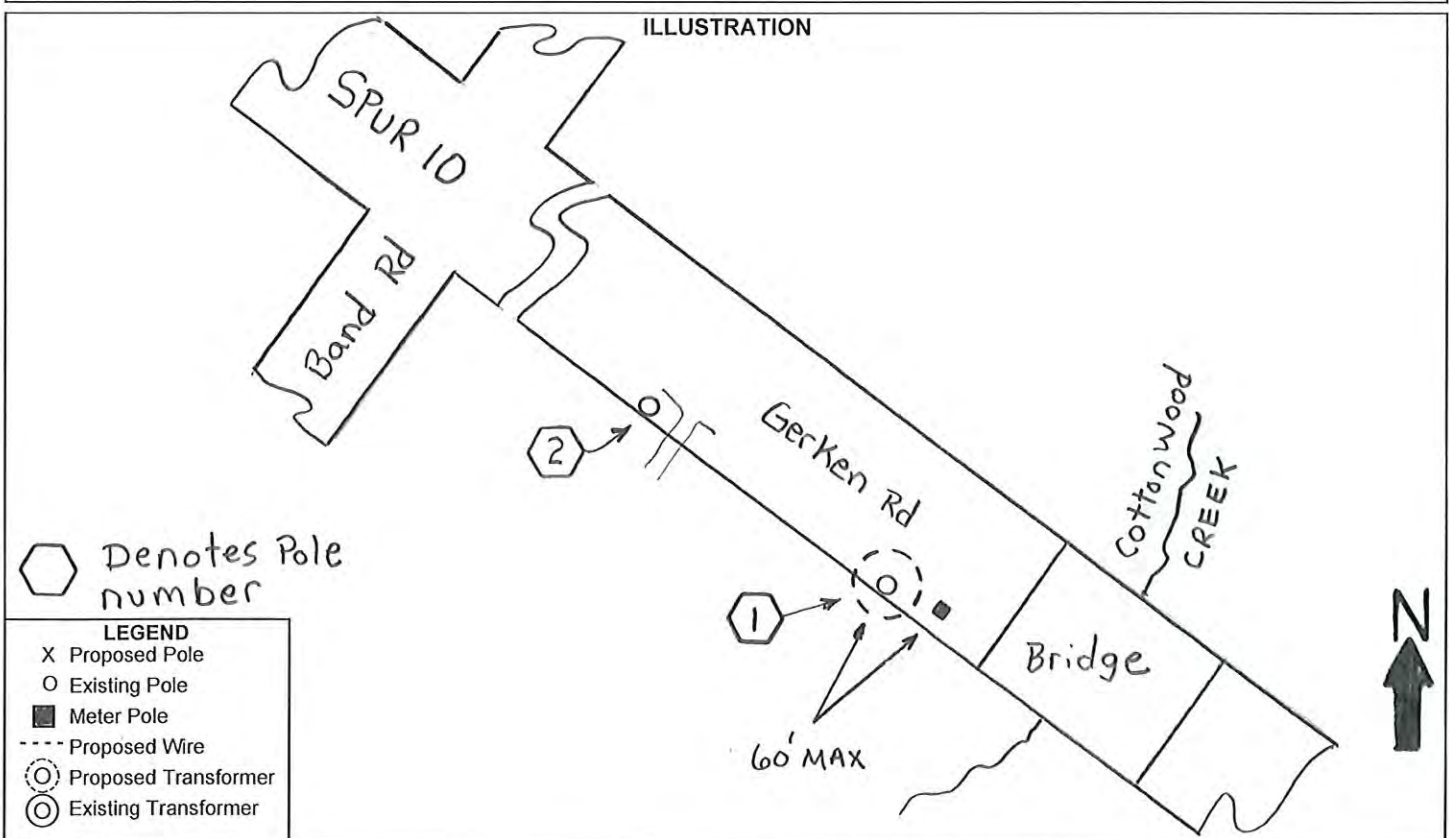

Taken from the CenterPoint Energy "Service Standards"

413 UNDERGROUND SERVICE LATERALS IN OVERHEAD AREAS

413.1 Requirements: It is necessary for Customers planning to install secondary underground service in Overhead Distribution Areas to consult the Service Consultant in the area to arrange for a Service Outlet Location and Data Statement as set forth in Article 203 and obtain the necessary Service Specifications for the installation. The Customer's underground riser conduit may be installed on CenterPoint Energy-poles where the pole is located on Customer's property or immediately adjacent in the street right-of-way or utility easement. Except for service transformer poles, customer riser conduit shall not be installed on poles with CenterPoint Energy power delivery equipment.

No more than four (4) conductors per phase and neutral shall be accepted per metered service (no more than 16 conductors per pole total for all services). Customer's conduit installed on poles shall be only rigid metal, intermediate metal, or PVC Schedule 80. When the underground service entrance conduit is PVC and the riser on the pole is rigid or intermediate metal conduit, the Customer or Customer's contractor shall install Supply Side Bonding Jumpers for all risers in accordance with requirements of the National Electrical Code.

Customer's service riser may be installed on a service pole if located on the Customer's property. Service poles will be provided ONLY if the standard service extension requires them. If service poles are not required for standard service extension, the Customer shall install and maintain a separate pole for the underground riser. **The maximum conduit riser attached directly to a pole shall not exceed one 3" conduit.** Larger conduit and multiple conduits may be installed on poles of sufficient strength, but they must be installed on stand-off brackets (See Illustration 13 – Conduit risers on stand-off brackets, next page). For non-wood poles, stand-off brackets may be banded to the pole with a minimum 3/4" Stainless Steel Band. Alternatively for fiberglass or ductile iron poles, bolt holes may be drilled with a carbide hole saw or carbide drill bit no closer than 4" apart. Unused drilled holes shall be plugged or covered. When the Company's poles with approved customer equipment attached need to be relocated or replaced, the customer is responsible for relocating all their equipment at their cost within 30 days of receipt of written notification.

Taken from the CenterPoint Energy “Service Standards”

422 METER POLE INSTALLATIONS

422.1 Requirements: A meter pole is required in those cases where suitable location, clearance, and anchorage as called for in Articles 403, 404 and 406 are not available on the Customer's premises. Even if the conditions set forth in Articles 403, 404 and 406 are satisfied, the Customer has the option to install a meter pole. Meter poles are installed and maintained by the customer at his expense and shall not be installed in utility easements. Meter poles required by the Company or at the Customer's discretion shall be a minimum 6" diameter wood pole or a steel pole of equivalent strength. The use of alternate types of meter poles must have Company approval before installation. All meter poles shall provide the point of attachment, clearances, and anchorage as described herein. The pole setting depth shall be a minimum of 4 ft., or 2 ft. plus 10% of the pole length, whichever is greater. Steel poles shall be truck accessible. The Company will not provide service to any customer owned steel pole that is not truck accessible. The customer must provide a readily accessible Service Disconnect at the meter pole.

422.3 Meter Seals: It is the practice of the Company to seal or lock all meters. Only the Company's agents and persons authorized by law are permitted to remove a Company seal or lock.

423 METER INSTALLATION SEQUENCE – 240V & BELOW SELF-CONTAINED

SERVICE – METER – SWITCH – FUSE – LOAD

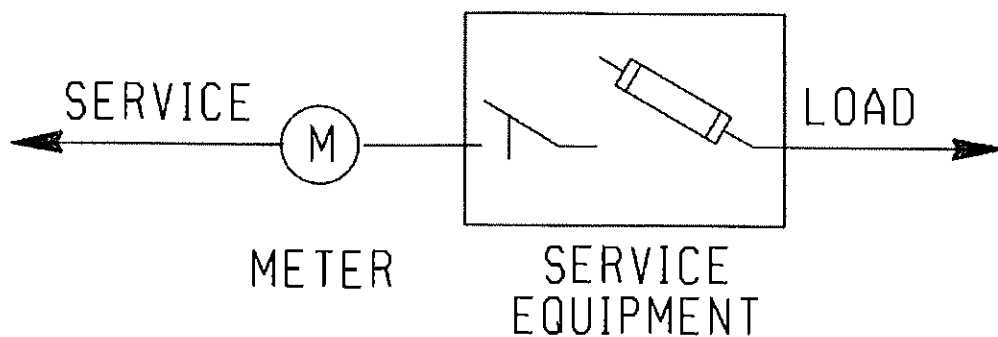

**TEXAS LAW AN ACT
TEXAS HEALTH AND SAFETY CODE TITLE 9**

CHAPTER 752 - Safety of persons engaged in activities in proximity of high voltage electric lines; restrictions

SECTION 001. DEFINITIONS

- (1) "High voltage" means more than 600 volts measured between conductors or between a conductor and the ground.
- (2) "Overhead line" means a bare or insulated electric conductor installed above ground but does not include a conductor that is de-energized and grounded or that is enclosed in a rigid metallic conduit.

SECTION 002. EXEMPTION FOR CERTAIN EMPLOYEES AND ACTIVITIES

(A) This chapter does not apply to the construction, reconstruction, operation, or maintenance by an authorized person of overhead electrical or communication circuits or conductors and their supporting structures and associated equipment that are part of a rail transportation system, an electrical generating, transmission, or distribution system or a communication system.

- (B) In this section, "authorized person" means:
- (1) an employee of a light and power company, an electric cooperative, or a municipality working on his employer's electrical system;
 - (2) an employee of a transportation system working on the system's electrical circuits;
 - (3) an employee of a communication utility;
 - (4) an employee of a state, county, or municipal agency that has authorized circuit construction on the poles or structures that belong to an electric power company, an electric cooperative, a municipal or transportation system, or a communication system;
 - (5) an employee of an industrial plant who works on the plant's electrical system; or
 - (6) an employee of an electrical or communications contractor who is working under the contractor's supervision.

SECTION 003. TEMPORARY CLEARANCE OF LINES

(A) A person, firm, corporation, or association responsible for temporary work or a temporary activity or function closer to a high voltage overhead line than the distances prescribed by this chapter must notify the operator of the line at least 48 hours before the work begins.

(B) A person, firm, corporation, or association may not begin the work, activity, or function under this section until the person, firm, corporation, or association responsible for the work, activity, or function and the owner or operator, or both, of the high voltage overhead line have negotiated a satisfactory mutual arrangement to provide temporary de-energization and grounding, temporary relocation or raising of the line, or temporary mechanical barriers to separate and prevent contact between the line and the material or equipment or the person performing the work, activity or function.

(C) The person, firm, corporation, or association responsible for the work, activity, or function shall pay the operator of the high voltage overhead line the actual expense incurred by the operator in providing the clearance prescribed in the agreement. The operator may require payment in advance and is not required to provide the clearance until the person, firm, corporation, or association responsible for the work, activity, or function makes the payment.

(D) If the actual expense of providing the clearance is less than the amount paid, the operator of the high voltage overhead line shall refund the surplus amount.

SECTION 004. RESTRICTION ON ALL ACTIVITIES NEAR LINES

(A) Unless a person, firm, corporation, or association effectively guards against danger by contact with the line as prescribed by Section 752.003, the person, firm, corporation, or association, either individually or through an agent or employee, may not perform a function or activity on land, a building, a highway, or other premises if at any time it is possible that the person performing the function or activity may:

- (1) move or be placed within six feet of a high voltage overhead line while performing the function or activity; or
- (2) bring any part of a tool, equipment, machine, or material within six feet of a high voltage overhead line while performing the function or activity.

(B) A person, firm, corporation, or association may not require an employee to perform a function or activity prohibited by Subsection (A).

SECTION 005. RESTRICTION ON OPERATION OF MACHINERY AND PLACEMENT OF STRUCTURES NEAR LINES

Unless a person, firm, corporation, or association effectively guards against danger by contact with the line as prescribed by Section 752.003, the person, firm, corporation, or association, either individually or through an agent or employee, may not:

- (1) erect, install, transport, or store all or any part of a house, building, or other structure within six feet of a high voltage overhead line;
- (2) install, operate, transport, handle, or store all or any part of a tool, machine, or equipment within six feet of a high voltage overhead line; or
- (3) transport, handle, or store all or any part of supplies or materials within six feet of a high voltage overhead line.

SECTION 006. RESTRICTION ON OPERATION OF CERTAIN MACHINERY OR EQUIPMENT

(A) A person, firm, corporation, or association, individually, through an agent or employee, or as an agent or employee, may not operate a crane, derrick, power shovel, drilling rig, hay loader, hay stacker, mechanical cotton picker, pile driver, hoisting equipment, or similar apparatus any part of which is capable of vertical, lateral, or swinging motion unless:

- (1) a warning sign is posted and maintained as prescribed by Subsections (B) and (C);
- (2) an insulated cage-type guard or protective device is installed about the boom or arm of the equipment, except a backhoe or dipper; and
- (3) each lifting line, if the equipment includes a lifting hook device, is equipped with an insulator link on the lift hook connection.

(B) The warning sign required by Subsection (A) (1) must be a weather-resistant sign of not less than five inches by seven inches with a yellow background and black lettering that reads:
"WARNING -- UNLAWFUL TO OPERATE THIS EQUIPMENT WITHIN TEN FEET OF HIGH VOLTAGE LINES."

- (C) The warning sign must be legible at 12 feet and placed:
- (1) within the equipment so that it is readily visible to the equipment operator while at the equipment controls; and
 - (2) on the outside of the equipment in the number and location necessary to make it readily visible to a mechanic or other person engaged in the work.

(D) Notwithstanding the distance limitations prescribed by Sections 752.004 and 752.005, unless a person, firm, corporation, or association effectively guards against danger by contact with the line as prescribed by Section 752.003, the person, firm, corporation, or association may not operate all or any part of a machine or equipment described by this section within 10 feet of a high voltage overhead line.

SECTION 007. CRIMINAL PENALTY

(A) A person, firm, corporation, or association or an agent or employee of a person, firm, corporation, or association commits an offense if the person, firm, corporation, association, agent, or employee violates this chapter.

(B) An offense under this section is punishable by a fine of not less than \$100 or more than \$1,000, confinement in jail for not more than one year, or both.

SECTION 008. LIABILITY FOR DAMAGES

If a violation of this chapter results in physical or electrical contact with a high voltage overhead line, the person, firm, corporation, or association that committed the violation is liable to the owner or operator of the line for all damages to the facilities and for all liability that the owner or operator incurs as a result of the contact.

Acts 1989, 71st Leg., ch. 678, § 1, eff. Sept. 1, 1989

Prior Laws:

Acts 1971, 62nd Leg., p. 76, ch. 41.

Vernon's Ann. Civ. St. art. 1436c, § 7(B).

This is only a part of the entire act. The complete act is available for review.



**SERVICE OUTLET LOCATION AND DATA STATEMENT
FOR ELECTRIC SERVICE**

6 of 7

PERMITTING ENTITY	PHONE NUMBER	LIFE OF PERMIT	TYPE RES	TYPE GEN
City of Alvin	281-388-4271	No limit*	E/M	E
City of Arcola	281-431-0606	6 months	F	F
City of Bayou Vista	409-935-8348	No limit*	E	E
City of Baytown	281-420-6537	90 days	E/M	O
City of Beach City	281-383-3180	6 months	E	E
City of Beasley	979-387-2775	90 days	E	E
BRAZORIA COUNTY	979-864-1295	1 year	F	F
City of Bellaire	713-662-8230	90 days	E	E
City of Brookshire	281-375-5050	6 months	E	E
City of Brookside Village	281-485-3048	90 days	E/M	E
City of Bunker Hill	713-467-9762	No limit*	E	E
CHAMBERS COUNTY	409-267-8392	90 days	F	F
City of Clear Lake Shores	281-334-2799	6 months	E	E
City of Clute	409-265-2541	6 months	E	E
City of Cove	281-573-8309	1 year	E	E
City of Danbury	979-922-1551	1 year	E	E
City of Dayton	936-258-2642	6 months	E	E
City of Deer Park	281-478-7270	1 year	E	O
City of Dickinson	281-337-6259	30 days	E	E
City of El Lago	281-326-1951	1 year	E	E
City of Freeport	979-233-3526	6 months	E/F/M	E/F
FORT BEND COUNTY	281-633-7502	1 year	F	F
City of Friendswood	281-996-3200	No limit*	E	E
City of Fulshear	281-346-1796	6 months	E	E
City of Galena Park	713-672-2556	90 days	E	E
City of Galveston	409-797-3660	6 months	E	E
GALVESTON COUNTY	409-770-5549	6 months	F	F
HARRIS COUNTY	713-956-3000	1 year	F	F
City of Hedwig Village	713-465-6009	6 months	E	E
City of Hillcrest	281-756-0577	6 months	E	E
City of Hillshire Village	713-973-1779	No limit*	E	E
City of Hitchcock	409-986-5591	6 months	E	E
City of Houston	832-394-8847	6 months	E/M	E
City of Humble	281-446-3061	90 days	E/M	E/O
City of Hunters Creek	713-465-2150	No limit*	E	E
City of Iowa Colony	281-369-2471	90 days	E	E
City of Jacinto City	713-674-8424	90 days	E	E
City of Jamaica Beach	409-737-1142	1 year	E	E
City of Jersey Village	713-466-2110	1 year	E/M	E
City of Jones Creek	409-233-1826	90 days	E	E
City of Katy	281-391-4830	180 days	E	E
City of Kemah	281-334-1611	6 months	E/M	E
City of Lake Jackson	979-415-2430	180 days	E	O
City of La Marque	409-938-9204	6 months	E/M	E
City of La Porte	281-471-5020	6 months	E/M	O
City of League City	281-554-1415	90 days	E	E



**SERVICE OUTLET LOCATION AND DATA STATEMENT
FOR ELECTRIC SERVICE**

PERMITTING ENTITY	PHONE NUMBER	LIFE OF PERMIT	TYPE RES	TYPE GEN
City of Magnolia	281-356-2266	1 year	E	E
City of Manvel	281-489-0630	1 year	E/M	E
City of Meadows Place	281-983-2950	1 year	E/M	E
City of Missouri City	281-403-8600	90 days	O	O
City of Mont Belvieu	281-576-2213	90 days	O	O
MONTGOMERY COUNTY	936-539-7836	1 year	F	F
City of Morgan's Point	281-471-2171	6 months	E	E
City of Nassau Bay	281-333-2108	6 months	E	E
City of Needville	409-793-4253	90 days	E/M	E
City of Oak Ridge North	281-292-4648	6 months	E	E
City of Old River Winfree	281-385-1735	90 days	E	E
City of Orchard	979-478-6893	180 days	E/M	O
City of Oyster Creek	979-233-0243	6 months	E	E
City of Pasadena	713-477-1511	90 days	E/M	O
City of Pattison	281-375-5550	6 months	E	E
City of Pearland	281-652-1638	6 months	E/M	O
City of Piney Point Village	713-782-0271	90 days	E	E
City of Quintana	979-233-0848	90 days	E	E
City of Richmond	281-232-6871	6 months	E/M	O
City of Richwood	979-265-2082	90 days	E	E
City of Rosenberg	1-832-595-3400	90 days	E/M	O
City of Santa Fe	409-925-6412	6 months	E/M	E
City of Seabrook	281-291-5668	6 months	E	E
City of Sealy	979-885-1669	90 days	E/M	E
City of Shoreacres	281-471-2253	1 year	E	E
City of South Houston	713-947-7700	6 months	E/M	O
City of Southside Place	713-668-2341	90 days	E	E
City of Spring Valley	713-465-8308	6 months	E	E
City of Stafford	281-261-3940	6 months	E/M	O
City of Sugar Land	281-275-2270	6 months	E/M	O
Village of Surfside Beach	979-233-1531	6 months	E	E
City of Taylor Lake Village	281-326-2843	90 days	E	E
City of Texas City	409-643-5946	30 days	E/M	E
City of Tomball	281-351-5484	6 months	E/M	E
Village of Tiki Island	409-935-1427	1 year	E	E
City of Waller	936-931-1042	1 year	E	E
City of Webster	281-338-2925	90 days	E	O
City of West University Place	713-662-5833	1 year	E	E
City of Weston Lakes	281-533-0907	90 days	F	F
City of Wharton	979-532-2491	6 months	E	E

* Duration of project

CODE TYPES

- E= All new meter Installation and wiring changes.
- O= For all MVI and Name changes including Mobile Homes
- F= All new permanent and/or temporary service.
- M= Mobile Homes

CenterPoint Energy Houston Electric, LLC
Applicable: Entire Service Area

CNP 8038

6.3 AGREEMENTS AND FORMS

6.3.1 FACILITIES EXTENSION AGREEMENT

This Facilities Extension Agreement is entered into by and between _____
Fort Bend County _____, herein
called "Retail Customer" and CenterPoint Energy Houston Electric, LLC, herein called
"Company" (hereinafter referred to as Agreement) for the construction, extension, installation,
modification, repair, upgrade, conversion, relocation, de-energization or removal of Company's
Delivery System, including temporary facilities (hereinafter referred to as facilities extension or
extension), as described herein.

This Agreement covers the facilities extension to Retail Customer location at _____
3730 Gerken Road (Spur 10 at Cottonwood Creek) _____ Layout #40

The Company agrees to accept payment of _____ \$ 1,674.00 _____ Dollars
to be paid by the Retail Customer, as a Non-Refundable Construction Payment in connection
with the Retail Customer request to extend Company facilities to the above described location as
follows: _____ Permanent service beyond allowable distance.

_____ Cost to hang overhead transformer.

- Unless otherwise stated by Company in writing, the Non-Refundable Construction Payment amount above is valid for twelve months.

In consideration of said Non-Refundable Payment, to be paid to Company by Retail Customer prior to commencement of construction, Company agrees to install and operate lines and equipment necessary to distribute electric service to the identified location under the following General Conditions:

- Company shall at all times have title to and complete ownership and control over facilities installed by Company.
- Retail Customer must make satisfactory payment arrangements (if payment is required to extend Company facilities) and sign and return this Agreement before Company can proceed with the requested extension.

CenterPoint Energy Houston Electric, LLC
Applicable: Entire Service Area

CNP 8038

- Extension of service facilities is contingent on acquisition of all necessary easements and rights of way.

Nothing herein contained within this Agreement shall be construed as a waiver or relinquishment by Company of any right that it has or may hereafter have to discontinue service for or on account of default in the payment of any bill owing or to become owing thereafter for any other reason or cause stated in Company's Tariff.

This Agreement shall not be binding upon Company unless and until it is signed by an authorized representative of the Company.

CenterPoint Energy Houston Electric, LLC

Fort Bend County

Retail Customer

By Gabriel Gonzalez

By 

Gabriel Gonzalez

KP George

(name printed or typed)

(name printed or typed)

Title Service Area Manager

Title County Judge

Date 12/29/2025

Date January 12, 2026



Please make check payable to:
CenterPoint Energy

Attn: FTB SDAC

For FedEx/UPS: 935 Highway 90 ALT, Rosenberg, Tx 77471

For USPS: 935 Highway 90 ALT, Rosenberg, Tx 77471

INVOICE

Customer Info:

2/14/25

Name:	Fort Bend County - Isabel R. Roberts				
Address:	3730 Gerken Road - (Spur 10 at Cottonwood Creek) Layout #40				
City:	Rosenberg	State:	TX	Zip	77471
Phone:	281-238-3565	Isabel.Roberts@fortbendcountytexas.gov			
Email:	jamie.kovar@fortbendcountytexas.gov				
CNP Representative:	Enrique Ramon	Phone:	281-341-4931		

Description		W/O #	Total
1	Permanent service beyond allowable distance	113635350	\$ 1,674.00
2			
3			
4			
5			
			\$1,674.00

**PLEASE MAIL PAYMENT TO THE ABOVE ADDRESS.
Processing of check may be delayed without the return of this invoice.**

Make all checks payable to: *CenterPoint Energy*

Please send a copy of this invoice along with the check. Charges good for 1 year from date of invoice.

Payment is required prior to release of construction work order

If you have any questions concerning this invoice, please contact your CNP Representative at number above.

Thank you for using CenterPoint Energy



SERVICE OUTLET LOCATION AND DATA STATEMENT FOR ELECTRIC SERVICE

Page 1 of 7

Table with 2 columns: Field Name and Value. Fields include CUSTOMER (Fort Bend County), SERVICE ADDRESS (14643 Buls Road), MAILING ADDRESS (301 Jackson Street), and ELECTRICIAN.

Dear Customer,

CenterPoint Energy Houston Electric, LLC is grateful to meet with you on, 09-10-2024 to discuss the requirements needed to provide you electric service.

Form with two columns of checkboxes. Left column: CenterPoint Energy Construction Required? YES, The following steps must be complete prior to construction: Pay any up-front contributions, Clear trees, Easement charges, Easement execution. Right column: To begin the process we request that you provide the following information: Site Plan and Elevation Plan, Site Plan: Electronic Copy, One Line Diagram, Load Analysis, Easements Required, Specifications on Modular Metering Enclosure.

Form with two columns: YES NO. Items include: Installation of meter pole or weather head, Obtain city or county permit, CenterPoint Energy will provide an ESI ID#, Choose a Competitive Retailer.

Want to start gas service? Go to move.centerpointenergy.com/move or call 800-752-8036 To learn more about energy efficiency programs, please visit centerpointefficiency.com

CenterPoint Energy Houston Electric, LLC's target completion date to provide your construction requirements, per the working sketch, is a mutually agreed upon negotiated date by CenterPoint Energy and customer. Please be aware our ability to meet the target completion date may be affected by weather, availability of construction crews and materials, ability to secure easements, and timely completion of your requirements (see above). In addition, as a condition to this service, you agree to comply with all of CenterPoint Energy standards, the National Electrical Code, the National Safety Code, all Occupational Safety and (OSHA) requirements, the International Building code and all local governing body codes.

We appreciate the opportunity to do business with you and look forward to the successful completion of this project. Your signature below insures that both parties understand the requirements toward completion that will allow you electrical service. Thanks for your cooperation in this matter.

Sincerely,

Service Consultant

Table with 2 columns: Field Name and Value. Fields include SERVICE CONSULTANT (Enrique Ramon Gabriel Gonzalez), ADDRESS (935 Highway 90 ALT Rosenberg, Texas 77471), and E-MAIL ADDRESS (enrique.ramon@centerpointenergy.com).

Table with 2 columns: Field Name and Value. Fields include CUSTOMER'S SIGNATURE (KP George), CUSTOMER'S PRINTED NAME (KP George), and DATE (January 12, 2026).

Form with two columns: YES NO. Items include: Will Customer have Back-up Generation?, Will Customer have Motor Greater than 250 HP?

Form with title APPLICABLE FORMS and a list of checkboxes: Power Quality, Primary Meter, Motor Start, Emergency Generation, Distributed Generation, Major UG Checklist.

20F7

<p align="center">GENERAL SERVICE</p> <p><input type="checkbox"/> 1Ø 3W 120/208</p> <p><input checked="" type="checkbox"/> 1Ø 3W 120/240</p> <p><input type="checkbox"/> 3Ø 4W Δ 240V</p> <p><input type="checkbox"/> 3Ø 4W Y 120/208V</p> <p><input type="checkbox"/> 3Ø 4W Y 277/480V* *10 X 26 PT can mounted on 480V Service?</p> <p><input type="checkbox"/> 3Ø 3W Δ 480V* *1-1/4" conduit connecting CT & PT can run?</p> <p><input type="checkbox"/> Primary Metering Job</p> <p><input type="checkbox"/> Major UG Job</p> <p><input type="checkbox"/> Other: (Explain) _____</p>	<p align="center">SERVICE TYPE</p> <p>_____ FT² <input checked="" type="checkbox"/> All Electric <input type="checkbox"/> Gas & Electric</p> <p>Size Wire Pulled _____</p> <p>Cust's Load 1 Ø <u>5</u> +3 Ø _____ = <u>5</u> Total KVA</p> <p>Fault Current: Initial <u>6,100</u> Ultimate <u>99,200</u></p> <p align="center">Amperes RMS Symmetrical at <u>240</u> Volts</p>
---	---

<p align="center">CT CAN TYPE</p> <p><input type="checkbox"/> 320 Amp (self contained)</p> <p><input type="checkbox"/> 30 X 42</p> <p><input type="checkbox"/> Bus Head Outdoor</p> <p><input type="checkbox"/> Bus Head with CT Can</p> <p><input type="checkbox"/> Stainless Steel Rack</p> <p><input type="checkbox"/> Primary Job</p>	<p align="center">CONDUITS ON POLE</p> <p align="center">Size of Conduit _____</p> <p align="center">No. of Conduits _____</p>	<p align="center">For Information Regarding:</p> <p align="center">CenterPoint Energy service standards visit</p> <p align="center">www.centerpointenergy.com/electricservicestandards</p> <p align="center">For approvals on AUTOMATIC TRANSFER SWITCHES</p> <p align="center">EMAIL SPECS TO</p> <p align="center">ATS.Approvals@CenterPointEnergy.com</p>
--	---	---

COMMENTS OR NOTES

Note: Customer may riser up existing Pole #1 or set Permanent meter Pole as shown on sketch below.

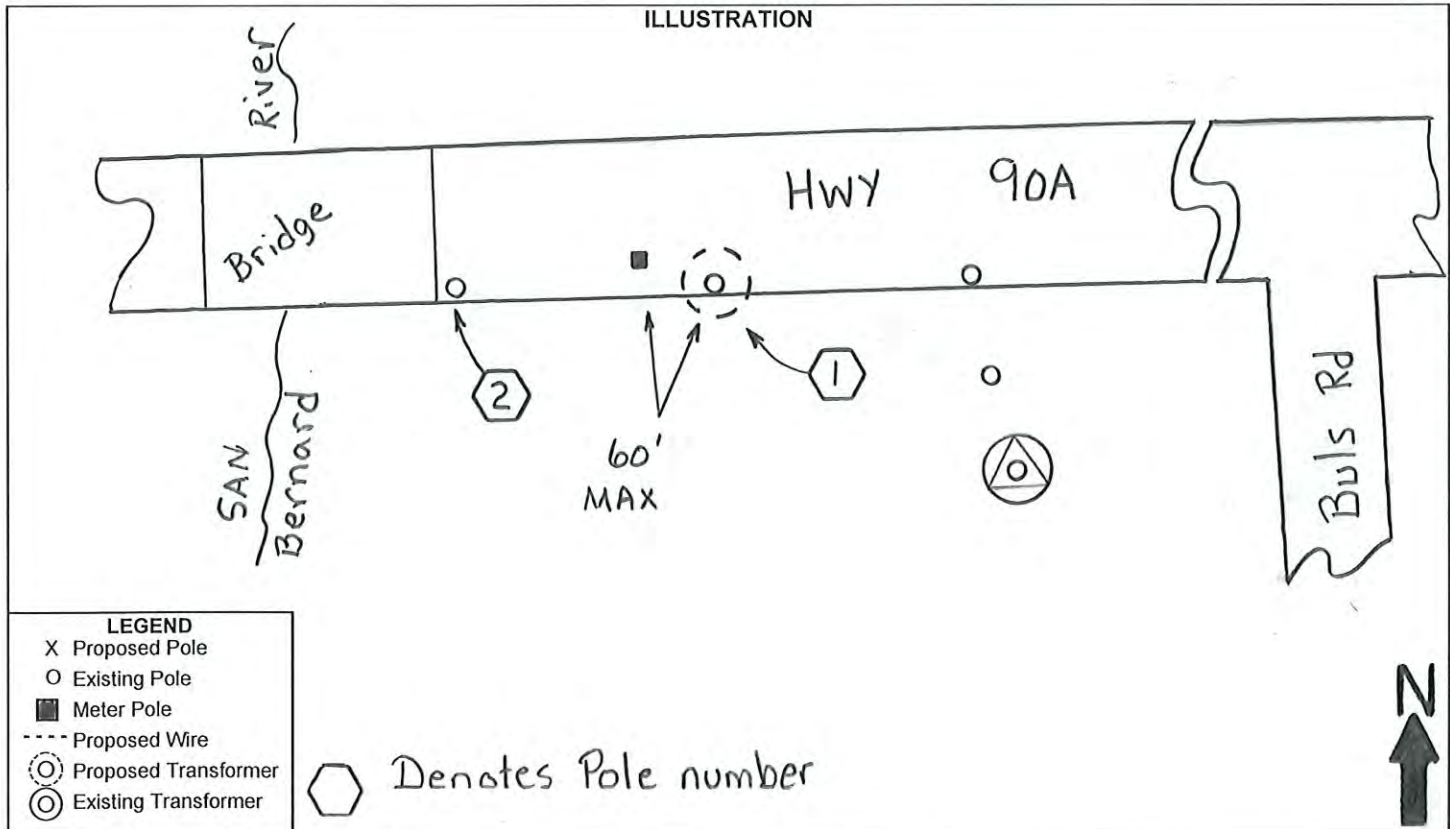

Taken from the CenterPoint Energy "Service Standards"

413 UNDERGROUND SERVICE LATERALS IN OVERHEAD AREAS

413.1 Requirements: It is necessary for Customers planning to install secondary underground service in Overhead Distribution Areas to consult the Service Consultant in the area to arrange for a Service Outlet Location and Data Statement as set forth in Article 203 and obtain the necessary Service Specifications for the installation. The Customer's underground riser conduit may be installed on CenterPoint Energy-poles where the pole is located on Customer's property or immediately adjacent in the street right-of-way or utility easement. Except for service transformer poles, customer riser conduit shall not be installed on poles with CenterPoint Energy power delivery equipment.

No more than four (4) conductors per phase and neutral shall be accepted per metered service (no more than 16 conductors per pole total for all services). Customer's conduit installed on poles shall be only rigid metal, intermediate metal, or PVC Schedule 80. When the underground service entrance conduit is PVC and the riser on the pole is rigid or intermediate metal conduit, the Customer or Customer's contractor shall install Supply Side Bonding Jumpers for all risers in accordance with requirements of the National Electrical Code.

Customer's service riser may be installed on a service pole if located on the Customer's property. Service poles will be provided ONLY if the standard service extension requires them. If service poles are not required for standard service extension, the Customer shall install and maintain a separate pole for the underground riser. **The maximum conduit riser attached directly to a pole shall not exceed one 3" conduit.** Larger conduit and multiple conduits may be installed on poles of sufficient strength, but they must be installed on stand-off brackets (See Illustration 13 – Conduit risers on stand-off brackets, next page). For non-wood poles, stand-off brackets may be banded to the pole with a minimum 3/4" Stainless Steel Band. Alternatively for fiberglass or ductile iron poles, bolt holes may be drilled with a carbide hole saw or carbide drill bit no closer than 4" apart. Unused drilled holes shall be plugged or covered. When the Company's poles with approved customer equipment attached need to be relocated or replaced, the customer is responsible for relocating all their equipment at their cost within 30 days of receipt of written notification.

Taken from the CenterPoint Energy “Service Standards”

422 METER POLE INSTALLATIONS

422.1 Requirements: A meter pole is required in those cases where suitable location, clearance, and anchorage as called for in Articles 403, 404 and 406 are not available on the Customer's premises. Even if the conditions set forth in Articles 403, 404 and 406 are satisfied, the Customer has the option to install a meter pole. Meter poles are installed and maintained by the customer at his expense and shall not be installed in utility easements. Meter poles required by the Company or at the Customer's discretion shall be a minimum 6" diameter wood pole or a steel pole of equivalent strength. The use of alternate types of meter poles must have Company approval before installation. All meter poles shall provide the point of attachment, clearances, and anchorage as described herein. The pole setting depth shall be a minimum of 4 ft., or 2 ft. plus 10% of the pole length, whichever is greater. Steel poles shall be truck accessible. The Company will not provide service to any customer owned steel pole that is not truck accessible. The customer must provide a readily accessible Service Disconnect at the meter pole.

422.3 Meter Seals: It is the practice of the Company to seal or lock all meters. Only the Company's agents and persons authorized by law are permitted to remove a Company seal or lock.

423 METER INSTALLATION SEQUENCE – 240V & BELOW SELF-CONTAINED

SERVICE – METER – SWITCH – FUSE – LOAD

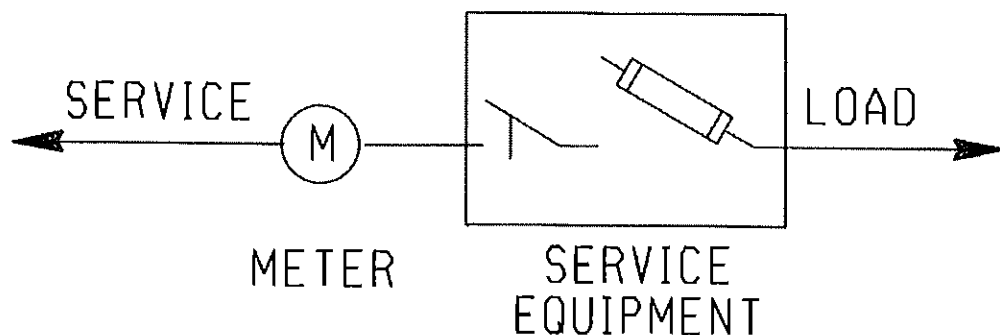

**TEXAS LAW AN ACT
TEXAS HEALTH AND SAFETY CODE TITLE 9**

CHAPTER 752 - Safety of persons engaged in activities in proximity of high voltage electric lines; restrictions

SECTION 001. DEFINITIONS

- (1) "High voltage" means more than 600 volts measured between conductors or between a conductor and the ground.
- (2) "Overhead line" means a bare or insulated electric conductor installed above ground but does not include a conductor that is de-energized and grounded or that is enclosed in a rigid metallic conduit.

SECTION 002. EXEMPTION FOR CERTAIN EMPLOYEES AND ACTIVITIES

(A) This chapter does not apply to the construction, reconstruction, operation, or maintenance by an authorized person of overhead electrical or communication circuits or conductors and their supporting structures and associated equipment that are part of a rail transportation system, an electrical generating, transmission, or distribution system or a communication system.

(B) In this section, "authorized person" means:

- (1) an employee of a light and power company, an electric cooperative, or a municipality working on his employer's electrical system;
- (2) an employee of a transportation system working on the system's electrical circuits;
- (3) an employee of a communication utility;
- (4) an employee of a state, county, or municipal agency that has authorized circuit construction on the poles or structures that belong to an electric power company, an electric cooperative, a municipal or transportation system, or a communication system;
- (5) an employee of an industrial plant who works on the plant's electrical system; or
- (6) an employee of an electrical or communications contractor who is working under the contractor's supervision.

SECTION 003. TEMPORARY CLEARANCE OF LINES

(A) A person, firm, corporation, or association responsible for temporary work or a temporary activity or function closer to a high voltage overhead line than the distances prescribed by this chapter must notify the operator of the line at least 48 hours before the work begins.

(B) A person, firm, corporation, or association may not begin the work, activity, or function under this section until the person, firm, corporation, or association responsible for the work, activity, or function and the owner or operator, or both, of the high voltage overhead line have negotiated a satisfactory mutual arrangement to provide temporary de-energization and grounding, temporary relocation or raising of the line, or temporary mechanical barriers to separate and prevent contact between the line and the material or equipment or the person performing the work, activity or function.

(C) The person, firm, corporation, or association responsible for the work, activity, or function shall pay the operator of the high voltage overhead line the actual expense incurred by the operator in providing the clearance prescribed in the agreement. The operator may require payment in advance and is not required to provide the clearance until the person, firm, corporation, or association responsible for the work, activity, or function makes the payment.

(D) If the actual expense of providing the clearance is less than the amount paid, the operator of the high voltage overhead line shall refund the surplus amount.

SECTION 004. RESTRICTION ON ALL ACTIVITIES NEAR LINES

(A) Unless a person, firm, corporation, or association effectively guards against danger by contact with the line as prescribed by Section 752.003, the person, firm, corporation, or association, either individually or through an agent or employee, may not perform a function or activity on land, a building, a highway, or other premises if at any time it is possible that the person performing the function or activity may:

- (1) move or be placed within six feet of a high voltage overhead line while performing the function or activity; or
- (2) bring any part of a tool, equipment, machine, or material within six feet of a high voltage overhead line while performing the function or activity.

(B) A person, firm, corporation, or association may not require an employee to perform a function or activity prohibited by Subsection (A).

SECTION 005. RESTRICTION ON OPERATION OF MACHINERY AND PLACEMENT OF STRUCTURES NEAR LINES

Unless a person, firm, corporation, or association effectively guards against danger by contact with the line as prescribed by Section 752.003, the person, firm, corporation, or association, either individually or through an agent or employee, may not:

- (1) erect, install, transport, or store all or any part of a house, building, or other structure within six feet of a high voltage overhead line;
- (2) install, operate, transport, handle, or store all or any part of a tool, machine, or equipment within six feet of a high voltage overhead line; or
- (3) transport, handle, or store all or any part of supplies or materials within six feet of a high voltage overhead line.

SECTION 006. RESTRICTION ON OPERATION OF CERTAIN MACHINERY OR EQUIPMENT

(A) A person, firm, corporation, or association, individually, through an agent or employee, or as an agent or employee, may not operate a crane, derrick, power shovel, drilling rig, hay loader, hay stacker, mechanical cotton picker, pile driver, hoisting equipment, or similar apparatus any part of which is capable of vertical, lateral, or swinging motion unless:

- (1) a warning sign is posted and maintained as prescribed by Subsections (B) and (C);
- (2) an insulated cage-type guard or protective device is installed about the boom or arm of the equipment, except a backhoe or dipper; and
- (3) each lifting line, if the equipment includes a lifting hook device, is equipped with an insulator link on the lift hook connection.

(B) The warning sign required by Subsection (A) (1) must be a weather-resistant sign of not less than five inches by seven inches with a yellow background and black lettering that reads:
"WARNING -- UNLAWFUL TO OPERATE THIS EQUIPMENT WITHIN TEN FEET OF HIGH VOLTAGE LINES."

(C) The warning sign must be legible at 12 feet and placed:

- (1) within the equipment so that it is readily visible to the equipment operator while at the equipment controls; and
- (2) on the outside of the equipment in the number and location necessary to make it readily visible to a mechanic or other person engaged in the work.

(D) Notwithstanding the distance limitations prescribed by Sections 752.004 and 752.005, unless a person, firm, corporation, or association effectively guards against danger by contact with the line as prescribed by Section 752.003, the person, firm, corporation, or association may not operate all or any part of a machine or equipment described by this section within 10 feet of a high voltage overhead line.

SECTION 007. CRIMINAL PENALTY

(A) A person, firm, corporation, or association or an agent or employee of a person, firm, corporation, or association commits an offense if the person, firm, corporation, association, agent, or employee violates this chapter.

(B) An offense under this section is punishable by a fine of not less than \$100 or more than \$1,000, confinement in jail for not more than one year, or both.

SECTION 008. LIABILITY FOR DAMAGES

If a violation of this chapter results in physical or electrical contact with a high voltage overhead line, the person, firm, corporation, or association that committed the violation is liable to the owner or operator of the line for all damages to the facilities and for all liability that the owner or operator incurs as a result of the contact.

Acts 1989, 71st Leg., ch. 678, § 1, eff. Sept. 1, 1989

Prior Laws:

Acts 1971, 62nd Leg., p. 76, ch. 41.

Vernon's Ann. Civ. St. art. 1436c, § 7(B).

This is only a part of the entire act. The complete act is available for review.



**SERVICE OUTLET LOCATION AND DATA STATEMENT
FOR ELECTRIC SERVICE**

6 of 7

PERMITTING ENTITY	PHONE NUMBER	LIFE OF PERMIT	TYPE RES	TYPE GEN
City of Alvin	281-388-4271	No limit*	E/M	E
City of Arcola	281-431-0606	6 months	F	F
City of Bayou Vista	409-935-8348	No limit*	E	E
City of Baytown	281-420-6537	90 days	E/M	O
City of Beach City	281-383-3180	6 months	E	E
City of Beasley	979-387-2775	90 days	E	E
BRAZORIA COUNTY	979-864-1295	1 year	F	F
City of Bellaire	713-662-8230	90 days	E	E
City of Brookshire	281-375-5050	6 months	E	E
City of Brookside Village	281-485-3048	90 days	E/M	E
City of Bunker Hill	713-467-9762	No limit*	E	E
CHAMBERS COUNTY	409-267-8392	90 days	F	F
City of Clear Lake Shores	281-334-2799	6 months	E	E
City of Clute	409-265-2541	6 months	E	E
City of Cove	281-573-8309	1 year	E	E
City of Danbury	979-922-1551	1 year	E	E
City of Dayton	936-258-2642	6 months	E	E
City of Deer Park	281-478-7270	1 year	E	O
City of Dickinson	281-337-6259	30 days	E	E
City of El Lago	281-326-1951	1 year	E	E
City of Freeport	979-233-3526	6 months	E/F/M	E/F
FORT BEND COUNTY	281-633-7502	1 year	F	F
City of Friendswood	281-996-3200	No limit*	E	E
City of Fulshear	281-346-1796	6 months	E	E
City of Galena Park	713-672-2556	90 days	E	E
City of Galveston	409-797-3660	6 months	E	E
GALVESTON COUNTY	409-770-5549	6 months	F	F
HARRIS COUNTY	713-956-3000	1 year	F	F
City of Hedwig Village	713-465-6009	6 months	E	E
City of Hillcrest	281-756-0577	6 months	E	E
City of Hillshire Village	713-973-1779	No limit*	E	E
City of Hitchcock	409-986-5591	6 months	E	E
City of Houston	832-394-8847	6 months	E/M	E
City of Humble	281-446-3061	90 days	E/M	E/O
City of Hunters Creek	713-465-2150	No limit*	E	E
City of Iowa Colony	281-369-2471	90 days	E	E
City of Jacinto City	713-674-8424	90 days	E	E
City of Jamaica Beach	409-737-1142	1 year	E	E
City of Jersey Village	713-466-2110	1 year	E/M	E
City of Jones Creek	409-233-1826	90 days	E	E
City of Katy	281-391-4830	180 days	E	E
City of Kemah	281-334-1611	6 months	E/M	E
City of Lake Jackson	979-415-2430	180 days	E	O
City of La Marque	409-938-9204	6 months	E/M	E
City of La Porte	281-471-5020	6 months	E/M	O
City of League City	281-554-1415	90 days	E	E



**SERVICE OUTLET LOCATION AND DATA STATEMENT
FOR ELECTRIC SERVICE**

PERMITTING ENTITY	PHONE NUMBER	LIFE OF PERMIT	TYPE RES	TYPE GEN
City of Magnolia	281-356-2266	1 year	E	E
City of Manvel	281-489-0630	1 year	E/M	E
City of Meadows Place	281-983-2950	1 year	E/M	E
City of Missouri City	281-403-8600	90 days	O	O
City of Mont Belvieu	281-576-2213	90 days	O	O
MONTGOMERY COUNTY	936-539-7836	1 year	F	F
City of Morgan's Point	281-471-2171	6 months	E	E
City of Nassau Bay	281-333-2108	6 months	E	E
City of Needville	409-793-4253	90 days	E/M	E
City of Oak Ridge North	281-292-4648	6 months	E	E
City of Old River Winfree	281-385-1735	90 days	E	E
City of Orchard	979-478-6893	180 days	E/M	O
City of Oyster Creek	979-233-0243	6 months	E	E
City of Pasadena	713-477-1511	90 days	E/M	O
City of Pattison	281-375-5550	6 months	E	E
City of Pearland	281-652-1638	6 months	E/M	O
City of Piney Point Village	713-782-0271	90 days	E	E
City of Quintana	979-233-0848	90 days	E	E
City of Richmond	281-232-6871	6 months	E/M	O
City of Richwood	979-265-2082	90 days	E	E
City of Rosenberg	1-832-595-3400	90 days	E/M	O
City of Santa Fe	409-925-6412	6 months	E/M	E
City of Seabrook	281-291-5668	6 months	E	E
City of Sealy	979-885-1669	90 days	E/M	E
City of Shoreacres	281-471-2253	1 year	E	E
City of South Houston	713-947-7700	6 months	E/M	O
City of Southside Place	713-668-2341	90 days	E	E
City of Spring Valley	713-465-8308	6 months	E	E
City of Stafford	281-261-3940	6 months	E/M	O
City of Sugar Land	281-275-2270	6 months	E/M	O
Village of Surfside Beach	979-233-1531	6 months	E	E
City of Taylor Lake Village	281-326-2843	90 days	E	E
City of Texas City	409-643-5946	30 days	E/M	E
City of Tomball	281-351-5484	6 months	E/M	E
Village of Tiki Island	409-935-1427	1 year	E	E
City of Waller	936-931-1042	1 year	E	E
City of Webster	281-338-2925	90 days	E	O
City of West University Place	713-662-5833	1 year	E	E
City of Weston Lakes	281-533-0907	90 days	F	F
City of Wharton	979-532-2491	6 months	E	E

* Duration of project

CODE TYPES

- E= All new meter Installation and wiring changes.
- O= For all MVI and Name changes including Mobile Homes
- F= All new permanent and/or temporary service.
- M= Mobile Homes

CenterPoint Energy Houston Electric, LLC
Applicable: Entire Service Area

CNP 8038

6.3 AGREEMENTS AND FORMS

6.3.1 FACILITIES EXTENSION AGREEMENT

This Facilities Extension Agreement is entered into by and between _____
Fort Bend County _____, herein
called "Retail Customer" and CenterPoint Energy Houston Electric, LLC, herein called
"Company" (hereinafter referred to as Agreement) for the construction, extension, installation,
modification, repair, upgrade, conversion, relocation, de-energization or removal of Company's
Delivery System, including temporary facilities (hereinafter referred to as facilities extension or
extension), as described herein.

This Agreement covers the facilities extension to Retail Customer location at _____
14643 Buls Road (US 90A at San Bernard River) _____ Layout #41

The Company agrees to accept payment of _____ \$ 1,673.00 _____ Dollars
to be paid by the Retail Customer, as a Non-Refundable Construction Payment in connection
with the Retail Customer request to extend Company facilities to the above described location as
follows: _____ Permanent service beyond allowable distance.

_____ Cost to hang overhead transformer.

- Unless otherwise stated by Company in writing, the Non-Refundable Construction Payment amount above is valid for twelve months.

In consideration of said Non-Refundable Payment, to be paid to Company by Retail Customer prior to commencement of construction, Company agrees to install and operate lines and equipment necessary to distribute electric service to the identified location under the following General Conditions:

- Company shall at all times have title to and complete ownership and control over facilities installed by Company.
- Retail Customer must make satisfactory payment arrangements (if payment is required to extend Company facilities) and sign and return this Agreement before Company can proceed with the requested extension.

CenterPoint Energy Houston Electric, LLC
Applicable: Entire Service Area

CNP 8038

- Extension of service facilities is contingent on acquisition of all necessary easements and rights of way.

Nothing herein contained within this Agreement shall be construed as a waiver or relinquishment by Company of any right that it has or may hereafter have to discontinue service for or on account of default in the payment of any bill owing or to become owing thereafter for any other reason or cause stated in Company's Tariff.

This Agreement shall not be binding upon Company unless and until it is signed by an authorized representative of the Company.

CenterPoint Energy Houston Electric, LLC

Fort Bend County

Retail Customer

By Gabriel Gonzalez

By KP George

Gabriel Gonzalez

KP George

(name printed or typed)

(name printed or typed)

Title Service Area Manager

Title County Judge

Date 12/29/2025

Date January 12, 2026



Please make check payable to:
CenterPoint Energy

Attn: FTB SDAC

For FedEx/UPS: 935 Highway 90 ALT, Rosenberg, Tx 77471

For USPS: 935 Highway 90 ALT, Rosenberg, Tx 77471

INVOICE

Customer Info:

2/14/25

Name:	Fort Bend County				
Address:	14643 Buls Road - (US 90A at San Bernard River) Layout #41				
City:	East Bernard	State:	TX	Zip	77435
Phone:	281-238-3565				
Email:	Isabel.roberts@fortbendcountytexas.gov				
CNP Representative:	Enrique Ramon	Phone:	281-341-4931		

	Description	W/O #	Total
1	Permanent service beyond allowable distance	113635349	\$ 1,673.00
2			
3			
4			
5			
			\$1,673.00

**PLEASE MAIL PAYMENT TO THE ABOVE ADDRESS.
Processing of check may be delayed without the return of this invoice.**

Make all checks payable to: *CenterPoint Energy*

Please send a copy of this invoice along with the check. Charges good for 1 year from date of invoice.

Payment is required prior to release of construction work order

If you have any questions concerning this invoice, please contact your CNP Representative at number above.

Thank you for using CenterPoint Energy



**SERVICE OUTLET LOCATION AND DATA STATEMENT
FOR ELECTRIC SERVICE**

CUSTOMER Fort Bend County	DAY PHONE (281) 238-3565
SERVICE ADDRESS 3721 FM 2919 Road (FM 2919 at San Bernard River)	Layout #42 EVENING PHONE (281) 642-5686
MAILING ADDRESS 301 Jackson Street Richmond, Tx 77469	CELL PHONE (281) 642-5686
ELECTRICIAN	ELECTRICIAN'S PHONE

Dear Customer,

CenterPoint Energy Houston Electric, LLC is grateful to meet with you on, 09-10-2024 to discuss the requirements needed to provide you electric service. DATE

<ul style="list-style-type: none"> • CenterPoint Energy Construction Required? <input checked="" type="checkbox"/> YES <input type="checkbox"/> NO • The following steps must be complete prior to construction: <ul style="list-style-type: none"> <input checked="" type="checkbox"/> Pay any up-front contributions for non-standard service \$ <u>1,674.00</u> <input type="checkbox"/> Clear trees along extension route <input type="checkbox"/> Easement charges \$ _____ <input type="checkbox"/> Easement execution 	<p>To begin the process we request that you provide the following information:</p> <ul style="list-style-type: none"> <input type="checkbox"/> Site Plan and Elevation Plan: Hard Copies <input type="checkbox"/> Site Plan: Electronic Copy with XY Coordinates <input type="checkbox"/> One Line Diagram <input type="checkbox"/> Load Analysis <input type="checkbox"/> Easements Required-Recorded Warranty Deed Required <input type="checkbox"/> Specifications on Modular Metering Enclosure.
---	--

<table border="0"> <tr> <td style="width: 50px;">YES</td> <td>NO</td> </tr> <tr> <td><input checked="" type="checkbox"/></td> <td><input type="checkbox"/> Installation of meter pole or weather head (as located on sketch).</td> </tr> <tr> <td><input checked="" type="checkbox"/></td> <td><input type="checkbox"/> Obtain city or county permit, if applicable. (See page 4 and 5)</td> </tr> <tr> <td><input checked="" type="checkbox"/></td> <td><input type="checkbox"/> CenterPoint Energy will provide an ESI ID# for your account to the email address provided as your project progresses. Please do not request a meter until the construction is completed.</td> </tr> <tr> <td><input checked="" type="checkbox"/></td> <td><input type="checkbox"/> Choose a Competitive Retailer - For listing, visit the website http://www.powertochoose.org or call 1-866-PWR-4-TEX (1-866-797-4839)</td> </tr> </table>	YES	NO	<input checked="" type="checkbox"/>	<input type="checkbox"/> Installation of meter pole or weather head (as located on sketch).	<input checked="" type="checkbox"/>	<input type="checkbox"/> Obtain city or county permit, if applicable. (See page 4 and 5)	<input checked="" type="checkbox"/>	<input type="checkbox"/> CenterPoint Energy will provide an ESI ID# for your account to the email address provided as your project progresses. Please do not request a meter until the construction is completed.	<input checked="" type="checkbox"/>	<input type="checkbox"/> Choose a Competitive Retailer - For listing, visit the website http://www.powertochoose.org or call 1-866-PWR-4-TEX (1-866-797-4839)
YES	NO									
<input checked="" type="checkbox"/>	<input type="checkbox"/> Installation of meter pole or weather head (as located on sketch).									
<input checked="" type="checkbox"/>	<input type="checkbox"/> Obtain city or county permit, if applicable. (See page 4 and 5)									
<input checked="" type="checkbox"/>	<input type="checkbox"/> CenterPoint Energy will provide an ESI ID# for your account to the email address provided as your project progresses. Please do not request a meter until the construction is completed.									
<input checked="" type="checkbox"/>	<input type="checkbox"/> Choose a Competitive Retailer - For listing, visit the website http://www.powertochoose.org or call 1-866-PWR-4-TEX (1-866-797-4839)									

Want to start gas service? Go to move.centerpointenergy.com/move or call 800-752-8036
To learn more about energy efficiency programs, please visit centerpointefficiency.com

CenterPoint Energy Houston Electric, LLC's target completion date to provide your construction requirements, per the working sketch, is a mutually agreed upon negotiated date by CenterPoint Energy and customer. *Please be aware our ability to meet the target completion date may be affected by weather, availability of construction crews and materials, ability to secure easements, and timely completion of your requirements (see above). In addition, as a condition to this service, you agree to comply with all of CenterPoint Energy standards, the National Electrical Code, the National Safety Code, all Occupational Safety and (OSHA) requirements, the International Building code and all local governing body codes.*

We appreciate the opportunity to do business with you and look forward to the successful completion of this project. Your signature below insures that both parties understand the requirements toward completion that will allow you electrical service. Thanks for your cooperation in this matter.

Sincerely,

Service Consultant

SERVICE CONSULTANT Enrique Ramon <i>Gabriel Gonzalez</i>	PHONE NUMBER (281) 341-4931
ADDRESS 935 Highway 90 ALT Rosenberg, Texas 77471	
E-MAIL ADDRESS enrique.ramon@centerpointenergy.com	

CUSTOMER'S SIGNATURE <i>KP George</i>	DATE January 12, 2026
CUSTOMER'S PRINTED NAME KP George	

YES	NO
<input type="checkbox"/>	<input checked="" type="checkbox"/> Will Customer have Back-up Generation?
<input type="checkbox"/>	<input checked="" type="checkbox"/> Will Customer have Motor Greater than 250 HP?

<p>APPLICABLE FORMS</p> <ul style="list-style-type: none"> <input type="checkbox"/> Power Quality <input type="checkbox"/> Primary Meter <input type="checkbox"/> Motor Start <input type="checkbox"/> Emergency Generation <input type="checkbox"/> Distributed Generation <input type="checkbox"/> Major UG Checklist
--

20F7

<p align="center">GENERAL SERVICE</p> <input type="checkbox"/> 1Ø 3W 120/208 <input checked="" type="checkbox"/> 1Ø 3W 120/240 <input type="checkbox"/> 3Ø 4W Δ 240V <input type="checkbox"/> 3Ø 4W Y 120/208V <input type="checkbox"/> 3Ø 4W Y 277/480V* *10 X 26 PT can mounted on 480V Service? <input type="checkbox"/> 3Ø 3W Δ 480V* *1-1/4" conduit connecting CT & PT can run? <input type="checkbox"/> Primary Metering Job <input type="checkbox"/> Major UG Job <input type="checkbox"/> Other: (Explain) _____ _____ _____		<p align="center">SERVICE TYPE</p> <p>_____ FT² <input checked="" type="checkbox"/> All Electric <input type="checkbox"/> Gas & Electric</p> <p>Size Wire Pulled _____</p> <p>Cust's Load 1 Ø <u>5</u> +3 Ø _____ = <u>5</u> Total KVA</p> <p>Fault Current: Initial <u>6,100</u> Ultimate <u>99,200</u></p> <p align="center">Amperes RMS Symmetrical at <u>240</u> Volts</p>	
<p align="center">CT CAN TYPE</p> <input type="checkbox"/> 320 Amp (self contained) <input type="checkbox"/> 30 X 42 <input type="checkbox"/> Bus Head Outdoor <input type="checkbox"/> Bus Head with CT Can <input type="checkbox"/> Stainless Steel Rack <input type="checkbox"/> Primary Job	<p align="center">CONDUITS ON POLE</p> <p align="center">Size of Conduit</p> <p align="center">_____</p> <p align="center">No. of Conduits</p> <p align="center">_____</p>	<p align="center">For Information Regarding:</p> <p align="center">CenterPoint Energy service standards visit</p> <p align="center">www.centerpointenergy.com/electricservicestandards</p> <p align="center">For approvals on AUTOMATIC TRANSFER SWITCHES</p> <p align="center">EMAIL SPECS TO</p> <p align="center">ATS.Approvals@CenterPointEnergy.com</p>	

COMMENTS OR NOTES

Note: Customer may riser up existing Pole #1 or set Permanent meter Pole as shown on sketch below.

ILLUSTRATION

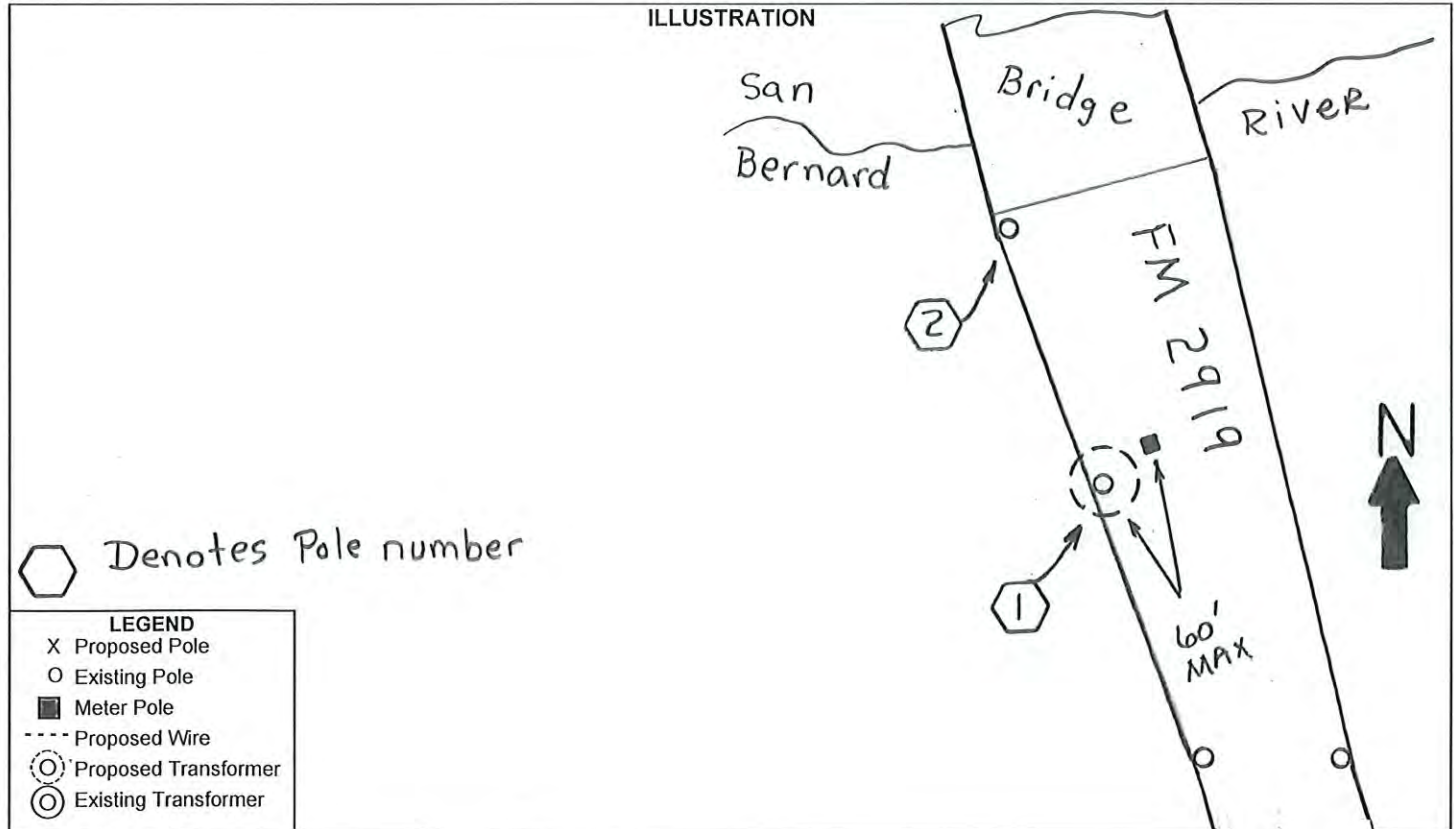

Taken from the CenterPoint Energy "Service Standards"

413 UNDERGROUND SERVICE LATERALS IN OVERHEAD AREAS

413.1 Requirements: It is necessary for Customers planning to install secondary underground service in Overhead Distribution Areas to consult the Service Consultant in the area to arrange for a Service Outlet Location and Data Statement as set forth in Article 203 and obtain the necessary Service Specifications for the installation. The Customer's underground riser conduit may be installed on CenterPoint Energy-poles where the pole is located on Customer's property or immediately adjacent in the street right-of-way or utility easement. Except for service transformer poles, customer riser conduit shall not be installed on poles with CenterPoint Energy power delivery equipment.

No more than four (4) conductors per phase and neutral shall be accepted per metered service (no more than 16 conductors per pole total for all services). Customer's conduit installed on poles shall be only rigid metal, intermediate metal, or PVC Schedule 80. When the underground service entrance conduit is PVC and the riser on the pole is rigid or intermediate metal conduit, the Customer or Customer's contractor shall install Supply Side Bonding Jumpers for all risers in accordance with requirements of the National Electrical Code.

Customer's service riser may be installed on a service pole if located on the Customer's property. Service poles will be provided ONLY if the standard service extension requires them. If service poles are not required for standard service extension, the Customer shall install and maintain a separate pole for the underground riser. **The maximum conduit riser attached directly to a pole shall not exceed one 3" conduit.** Larger conduit and multiple conduits may be installed on poles of sufficient strength, but they must be installed on stand-off brackets (See Illustration 13 – Conduit risers on stand-off brackets, next page). For non-wood poles, stand-off brackets may be banded to the pole with a minimum 3/4" Stainless Steel Band. Alternatively for fiberglass or ductile iron poles, bolt holes may be drilled with a carbide hole saw or carbide drill bit no closer than 4" apart. Unused drilled holes shall be plugged or covered. When the Company's poles with approved customer equipment attached need to be relocated or replaced, the customer is responsible for relocating all their equipment at their cost within 30 days of receipt of written notification.

Taken from the CenterPoint Energy “Service Standards”

422 METER POLE INSTALLATIONS

422.1 Requirements: A meter pole is required in those cases where suitable location, clearance, and anchorage as called for in Articles 403, 404 and 406 are not available on the Customer's premises. Even if the conditions set forth in Articles 403, 404 and 406 are satisfied, the Customer has the option to install a meter pole. Meter poles are installed and maintained by the customer at his expense and shall not be installed in utility easements. Meter poles required by the Company or at the Customer's discretion shall be a minimum 6" diameter wood pole or a steel pole of equivalent strength. The use of alternate types of meter poles must have Company approval before installation. All meter poles shall provide the point of attachment, clearances, and anchorage as described herein. The pole setting depth shall be a minimum of 4 ft., or 2 ft. plus 10% of the pole length, whichever is greater. Steel poles shall be truck accessible. The Company will not provide service to any customer owned steel pole that is not truck accessible. The customer must provide a readily accessible Service Disconnect at the meter pole.

422.3 Meter Seals: It is the practice of the Company to seal or lock all meters. Only the Company's agents and persons authorized by law are permitted to remove a Company seal or lock.

**423 METER INSTALLATION SEQUENCE – 240V & BELOW
SELF-CONTAINED**

SERVICE – METER – SWITCH – FUSE – LOAD

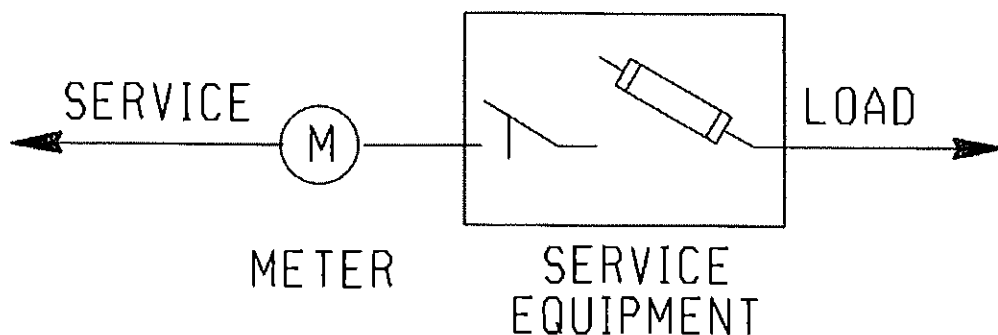

**TEXAS LAW AN ACT
TEXAS HEALTH AND SAFETY CODE TITLE 9**

CHAPTER 752 - Safety of persons engaged in activities in proximity of high voltage electric lines; restrictions

SECTION 001. DEFINITIONS

- (1) "High voltage" means more than 600 volts measured between conductors or between a conductor and the ground.
- (2) "Overhead line" means a bare or insulated electric conductor installed above ground but does not include a conductor that is de-energized and grounded or that is enclosed in a rigid metallic conduit.

SECTION 002. EXEMPTION FOR CERTAIN EMPLOYEES AND ACTIVITIES

(A) This chapter does not apply to the construction, reconstruction, operation, or maintenance by an authorized person of overhead electrical or communication circuits or conductors and their supporting structures and associated equipment that are part of a rail transportation system, an electrical generating, transmission, or distribution system or a communication system.

- (B) In this section, "authorized person" means:
- (1) an employee of a light and power company, an electric cooperative, or a municipality working on his employer's electrical system;
 - (2) an employee of a transportation system working on the system's electrical circuits;
 - (3) an employee of a communication utility;
 - (4) an employee of a state, county, or municipal agency that has authorized circuit construction on the poles or structures that belong to an electric power company, an electric cooperative, a municipal or transportation system, or a communication system;
 - (5) an employee of an industrial plant who works on the plant's electrical system; or
 - (6) an employee of an electrical or communications contractor who is working under the contractor's supervision.

SECTION 003. TEMPORARY CLEARANCE OF LINES

(A) A person, firm, corporation, or association responsible for temporary work or a temporary activity or function closer to a high voltage overhead line than the distances prescribed by this chapter must notify the operator of the line at least 48 hours before the work begins.

(B) A person, firm, corporation, or association may not begin the work, activity, or function under this section until the person, firm, corporation, or association responsible for the work, activity, or function and the owner or operator, or both, of the high voltage overhead line have negotiated a satisfactory mutual arrangement to provide temporary de-energization and grounding, temporary relocation or raising of the line, or temporary mechanical barriers to separate and prevent contact between the line and the material or equipment or the person performing the work, activity or function.

(C) The person, firm, corporation, or association responsible for the work, activity, or function shall pay the operator of the high voltage overhead line the actual expense incurred by the operator in providing the clearance prescribed in the agreement. The operator may require payment in advance and is not required to provide the clearance until the person, firm, corporation, or association responsible for the work, activity, or function makes the payment.

(D) If the actual expense of providing the clearance is less than the amount paid, the operator of the high voltage overhead line shall refund the surplus amount.

SECTION 004. RESTRICTION ON ALL ACTIVITIES NEAR LINES

(A) Unless a person, firm, corporation, or association effectively guards against danger by contact with the line as prescribed by Section 752.003, the person, firm, corporation, or association, either individually or through an agent or employee, may not perform a function or activity on land, a building, a highway, or other premises if at any time it is possible that the person performing the function or activity may:

- (1) move or be placed within six feet of a high voltage overhead line while performing the function or activity; or
- (2) bring any part of a tool, equipment, machine, or material within six feet of a high voltage overhead line while performing the function or activity.

(B) A person, firm, corporation, or association may not require an employee to perform a function or activity prohibited by Subsection (A).

SECTION 005. RESTRICTION ON OPERATION OF MACHINERY AND PLACEMENT OF STRUCTURES NEAR LINES

Unless a person, firm, corporation, or association effectively guards against danger by contact with the line as prescribed by Section 752.003, the person, firm, corporation, or association, either individually or through an agent or employee, may not:

- (1) erect, install, transport, or store all or any part of a house, building, or other structure within six feet of a high voltage overhead line;
- (2) install, operate, transport, handle, or store all or any part of a tool, machine, or equipment within six feet of a high voltage overhead line; or
- (3) transport, handle, or store all or any part of supplies or materials within six feet of a high voltage overhead line.

SECTION 006. RESTRICTION ON OPERATION OF CERTAIN MACHINERY OR EQUIPMENT

(A) A person, firm, corporation, or association, individually, through an agent or employee, or as an agent or employee, may not operate a crane, derrick, power shovel, drilling rig, hay loader, hay stacker, mechanical cotton picker, pile driver, hoisting equipment, or similar apparatus any part of which is capable of vertical, lateral, or swinging motion unless:

- (1) a warning sign is posted and maintained as prescribed by Subsections (B) and (C);
- (2) an insulated cage-type guard or protective device is installed about the boom or arm of the equipment, except a backhoe or dipper; and
- (3) each lifting line, if the equipment includes a lifting hook device, is equipped with an insulator link on the lift hook connection.

(B) The warning sign required by Subsection (A) (1) must be a weather-resistant sign of not less than five inches by seven inches with a yellow background and black lettering that reads:
"WARNING -- UNLAWFUL TO OPERATE THIS EQUIPMENT WITHIN TEN FEET OF HIGH VOLTAGE LINES."

- (C) The warning sign must be legible at 12 feet and placed:
- (1) within the equipment so that it is readily visible to the equipment operator while at the equipment controls; and
 - (2) on the outside of the equipment in the number and location necessary to make it readily visible to a mechanic or other person engaged in the work.

(D) Notwithstanding the distance limitations prescribed by Sections 752.004 and 752.005, unless a person, firm, corporation, or association effectively guards against danger by contact with the line as prescribed by Section 752.003, the person, firm, corporation, or association may not operate all or any part of a machine or equipment described by this section within 10 feet of a high voltage overhead line.

SECTION 007. CRIMINAL PENALTY

(A) A person, firm, corporation, or association or an agent or employee of a person, firm, corporation, or association commits an offense if the person, firm, corporation, association, agent, or employee violates this chapter.

(B) An offense under this section is punishable by a fine of not less than \$100 or more than \$1,000, confinement in jail for not more than one year, or both.

SECTION 008. LIABILITY FOR DAMAGES

If a violation of this chapter results in physical or electrical contact with a high voltage overhead line, the person, firm, corporation, or association that committed the violation is liable to the owner or operator of the line for all damages to the facilities and for all liability that the owner or operator incurs as a result of the contact.

Acts 1989, 71st Leg., ch. 678, § 1, eff. Sept. 1, 1989

Prior Laws:

Acts 1971, 62nd Leg., p. 76, ch. 41.

Vernon's Ann. Civ. St. art. 1436c, § 7(B).

This is only a part of the entire act. The complete act is available for review.



**SERVICE OUTLET LOCATION AND DATA STATEMENT
FOR ELECTRIC SERVICE**

6 of 7

PERMITTING ENTITY	PHONE NUMBER	LIFE OF PERMIT	TYPE RES	TYPE GEN
City of Alvin	281-388-4271	No limit*	E/M	E
City of Arcola	281-431-0606	6 months	F	F
City of Bayou Vista	409-935-8348	No limit*	E	E
City of Baytown	281-420-6537	90 days	E/M	O
City of Beach City	281-383-3180	6 months	E	E
City of Beasley	979-387-2775	90 days	E	E
BRAZORIA COUNTY	979-864-1295	1 year	F	F
City of Bellaire	713-662-8230	90 days	E	E
City of Brookshire	281-375-5050	6 months	E	E
City of Brookside Village	281-485-3048	90 days	E/M	E
City of Bunker Hill	713-467-9762	No limit*	E	E
CHAMBERS COUNTY	409-267-8392	90 days	F	F
City of Clear Lake Shores	281-334-2799	6 months	E	E
City of Clute	409-265-2541	6 months	E	E
City of Cove	281-573-8309	1 year	E	E
City of Danbury	979-922-1551	1 year	E	E
City of Dayton	936-258-2642	6 months	E	E
City of Deer Park	281-478-7270	1 year	E	O
City of Dickinson	281-337-6259	30 days	E	E
City of El Lago	281-326-1951	1 year	E	E
City of Freeport	979-233-3526	6 months	E/F/M	E/F
FORT BEND COUNTY	281-633-7502	1 year	F	F
City of Friendswood	281-996-3200	No limit*	E	E
City of Fulshear	281-346-1796	6 months	E	E
City of Galena Park	713-672-2556	90 days	E	E
City of Galveston	409-797-3660	6 months	E	E
GALVESTON COUNTY	409-770-5549	6 months	F	F
HARRIS COUNTY	713-956-3000	1 year	F	F
City of Hedwig Village	713-465-6009	6 months	E	E
City of Hillcrest	281-756-0577	6 months	E	E
City of Hillshire Village	713-973-1779	No limit*	E	E
City of Hitchcock	409-986-5591	6 months	E	E
City of Houston	832-394-8847	6 months	E/M	E
City of Humble	281-446-3061	90 days	E/M	E/O
City of Hunters Creek	713-465-2150	No limit*	E	E
City of Iowa Colony	281-369-2471	90 days	E	E
City of Jacinto City	713-674-8424	90 days	E	E
City of Jamaica Beach	409-737-1142	1 year	E	E
City of Jersey Village	713-466-2110	1 year	E/M	E
City of Jones Creek	409-233-1826	90 days	E	E
City of Katy	281-391-4830	180 days	E	E
City of Kemah	281-334-1611	6 months	E/M	E
City of Lake Jackson	979-415-2430	180 days	E	O
City of La Marque	409-938-9204	6 months	E/M	E
City of La Porte	281-471-5020	6 months	E/M	O
City of League City	281-554-1415	90 days	E	E



**SERVICE OUTLET LOCATION AND DATA STATEMENT
FOR ELECTRIC SERVICE**

PERMITTING ENTITY	PHONE NUMBER	LIFE OF PERMIT	TYPE RES	TYPE GEN
City of Magnolia	281-356-2266	1 year	E	E
City of Manvel	281-489-0630	1 year	E/M	E
City of Meadows Place	281-983-2950	1 year	E/M	E
City of Missouri City	281-403-8600	90 days	O	O
City of Mont Belvieu	281-576-2213	90 days	O	O
MONTGOMERY COUNTY	936-539-7836	1 year	F	F
City of Morgan's Point	281-471-2171	6 months	E	E
City of Nassau Bay	281-333-2108	6 months	E	E
City of Needville	409-793-4253	90 days	E/M	E
City of Oak Ridge North	281-292-4648	6 months	E	E
City of Old River Winfree	281-385-1735	90 days	E	E
City of Orchard	979-478-6893	180 days	E/M	O
City of Oyster Creek	979-233-0243	6 months	E	E
City of Pasadena	713-477-1511	90 days	E/M	O
City of Pattison	281-375-5550	6 months	E	E
City of Pearland	281-652-1638	6 months	E/M	O
City of Piney Point Village	713-782-0271	90 days	E	E
City of Quintana	979-233-0848	90 days	E	E
City of Richmond	281-232-6871	6 months	E/M	O
City of Richwood	979-265-2082	90 days	E	E
City of Rosenberg	1-832-595-3400	90 days	E/M	O
City of Santa Fe	409-925-6412	6 months	E/M	E
City of Seabrook	281-291-5668	6 months	E	E
City of Sealy	979-885-1669	90 days	E/M	E
City of Shoreacres	281-471-2253	1 year	E	E
City of South Houston	713-947-7700	6 months	E/M	O
City of Southside Place	713-668-2341	90 days	E	E
City of Spring Valley	713-465-8308	6 months	E	E
City of Stafford	281-261-3940	6 months	E/M	O
City of Sugar Land	281-275-2270	6 months	E/M	O
Village of Surfside Beach	979-233-1531	6 months	E	E
City of Taylor Lake Village	281-326-2843	90 days	E	E
City of Texas City	409-643-5946	30 days	E/M	E
City of Tomball	281-351-5484	6 months	E/M	E
Village of Tiki Island	409-935-1427	1 year	E	E
City of Waller	936-931-1042	1 year	E	E
City of Webster	281-338-2925	90 days	E	O
City of West University Place	713-662-5833	1 year	E	E
City of Weston Lakes	281-533-0907	90 days	F	F
City of Wharton	979-532-2491	6 months	E	E

* Duration of project

CODE TYPES

- E= All new meter Installation and wiring changes.
- O= For all MVI and Name changes including Mobile Homes
- F= All new permanent and/or temporary service.
- M= Mobile Homes

CenterPoint Energy Houston Electric, LLC
Applicable: Entire Service Area

CNP 8038

6.3 AGREEMENTS AND FORMS

6.3.1 FACILITIES EXTENSION AGREEMENT

This Facilities Extension Agreement is entered into by and between _____
Fort Bend County _____, herein
called "Retail Customer" and CenterPoint Energy Houston Electric, LLC, herein called
"Company" (hereinafter referred to as Agreement) for the construction, extension, installation,
modification, repair, upgrade, conversion, relocation, de-energization or removal of Company's
Delivery System, including temporary facilities (hereinafter referred to as facilities extension or
extension), as described herein.

This Agreement covers the facilities extension to Retail Customer location at _____
3721 FM 2919 Road (FM 2919 at San Bernard River) _____ Layout #42

The Company agrees to accept payment of _____ \$ 1,674.00 _____ Dollars
to be paid by the Retail Customer, as a Non-Refundable Construction Payment in connection
with the Retail Customer request to extend Company facilities to the above described location as
follows: _____ Permanent service beyond allowable distance.

_____ Cost to hang overhead transformer.

- Unless otherwise stated by Company in writing, the Non-Refundable Construction Payment amount above is valid for twelve months.

In consideration of said Non-Refundable Payment, to be paid to Company by Retail Customer prior to commencement of construction, Company agrees to install and operate lines and equipment necessary to distribute electric service to the identified location under the following General Conditions:

- Company shall at all times have title to and complete ownership and control over facilities installed by Company.
- Retail Customer must make satisfactory payment arrangements (if payment is required to extend Company facilities) and sign and return this Agreement before Company can proceed with the requested extension.

CenterPoint Energy Houston Electric, LLC
Applicable: Entire Service Area

CNP 8038

- Extension of service facilities is contingent on acquisition of all necessary easements and rights of way.

Nothing herein contained within this Agreement shall be construed as a waiver or relinquishment by Company of any right that it has or may hereafter have to discontinue service for or on account of default in the payment of any bill owing or to become owing thereafter for any other reason or cause stated in Company's Tariff.

This Agreement shall not be binding upon Company unless and until it is signed by an authorized representative of the Company.

CenterPoint Energy Houston Electric, LLC

Fort Bend County

Retail Customer

By Gabriel Gonzalez

By KP George

Gabriel Gonzalez
(name printed or typed)

KP George
(name printed or typed)

Title Service Area Manager

Title County Judge

Date 12/29/2025

Date January 12, 2026



Please make check payable to:
CenterPoint Energy

Attn: FTB SDAC

For FedEx/UPS: 935 Highway 90 ALT, Rosenberg, Tx 77471

For USPS: 935 Highway 90 ALT, Rosenberg, Tx 77471

INVOICE

Customer Info:

2/14/25

Name:	Fort Bend County				
Address:	3721 FM 2919 Road - (FM 2919 at San Bernard River) Layout #42				
City:	Beasley	State:	TX	Zip	77417
Phone:	281-238-3565				
Email:	Isabel.Roberts@fortbendcountytexas.gov				
CNP Representative:	Enrique Ramon	Phone:	281-341-4931		

Description		W/O #	Total
1	Permanent service beyond allowable distance	113634687	\$ 1,674.00
2			
3			
4			
5			
			\$1,674.00

**PLEASE MAIL PAYMENT TO THE ABOVE ADDRESS.
Processing of check may be delayed without the return of this invoice.**

Make all checks payable to: *CenterPoint Energy*

Please send a copy of this invoice along with the check. Charges good for 1 year from date of invoice.

Payment is required prior to release of construction work order

If you have any questions concerning this invoice, please contact your CNP Representative at number above.

Thank you for using CenterPoint Energy



SERVICE OUTLET LOCATION AND DATA STATEMENT FOR ELECTRIC SERVICE

Page 1 of 7

Table with 2 columns: Field Name (CUSTOMER, SERVICE ADDRESS, MAILING ADDRESS, ELECTRICIAN) and Field Value (Fort Bend County, 14703 US Highway 59, 301 Jackson Street, etc.)

Dear Customer,

CenterPoint Energy Houston Electric, LLC is grateful to meet with you on, 09-10-2024 to discuss the requirements needed to provide you electric service.

Form with two columns: Requirements (CenterPoint Energy Construction Required?, Pay any up-front contributions, etc.) and Information Requested (Site Plan and Elevation Plan, etc.)

Form with YES/NO columns for: Installation of meter pole or weather head, Obtain city or county permit, etc.

Want to start gas service? Go to move.centerpointenergy.com/move or call 800-752-8036 To learn more about energy efficiency programs, please visit centerpointefficiency.com

CenterPoint Energy Houston Electric, LLC's target completion date to provide your construction requirements, per the working sketch, is a mutually agreed upon negotiated date by CenterPoint Energy and customer.

We appreciate the opportunity to do business with you and look forward to the successful completion of this project. Your signature below insures that both parties understand the requirements toward completion that will allow you electrical service.

Sincerely,

Service Consultant

Form for Service Consultant: Enrique Ramon Gabriel Gonzalez, 935 Highway 90 ALT Rosenberg, Texas 77471

Form for Customer's Signature: KP George, January 12, 2026

Form with YES/NO columns for: Will Customer have Back-up Generation?, Will Customer have Motor Greater than 250 HP?

Form titled APPLICABLE FORMS with checkboxes for Power Quality, Primary Meter, Motor Start, Emergency Generation, Distributed Generation, Major UG Checklist

GENERAL SERVICE	SERVICE TYPE
<input type="checkbox"/> 1Ø 3W 120/208 <input checked="" type="checkbox"/> 1Ø 3W 120/240 <input type="checkbox"/> 3Ø 4W Δ 240V <input type="checkbox"/> 3Ø 4W Y 120/208V <input type="checkbox"/> 3Ø 4W Y 277/480V* *10 X 26 PT can mounted on 480V Service? <input type="checkbox"/> 3Ø 3W Δ 480V* *1-1/4" conduit connecting CT & PT can run? <input type="checkbox"/> Primary Metering Job <input type="checkbox"/> Major UG Job <input type="checkbox"/> Other: (Explain) _____	_____ FT ² <input checked="" type="checkbox"/> All Electric <input type="checkbox"/> Gas & Electric Size Wire Pulled _____ Cust's Load 1 Ø <u>5</u> +3 Ø _____ = _____ Total KVA Fault Current: Initial <u>6,100</u> Ultimate <u>99,200</u> Amperes RMS Symmetrical at <u>240</u> Volts

CT CAN TYPE	CONDUITS ON POLE	For Information Regarding:
<input type="checkbox"/> 320 Amp (self contained) <input type="checkbox"/> 30 X 42 <input type="checkbox"/> Bus Head Outdoor <input type="checkbox"/> Bus Head with CT Can <input type="checkbox"/> Stainless Steel Rack <input type="checkbox"/> Primary Job	Size of Conduit _____ No. of Conduits _____	<p>CenterPoint Energy service standards visit www.centerpointenergy.com/electricservicestandards</p> <p>For approvals on AUTOMATIC TRANSFER SWITCHES EMAIL SPECS TO ATS.Approvals@CenterPointEnergy.com</p>

COMMENTS OR NOTES
 Note: Customer may riser up existing Pole #1 or set Permanent Meter Pole as shown on sketch below.

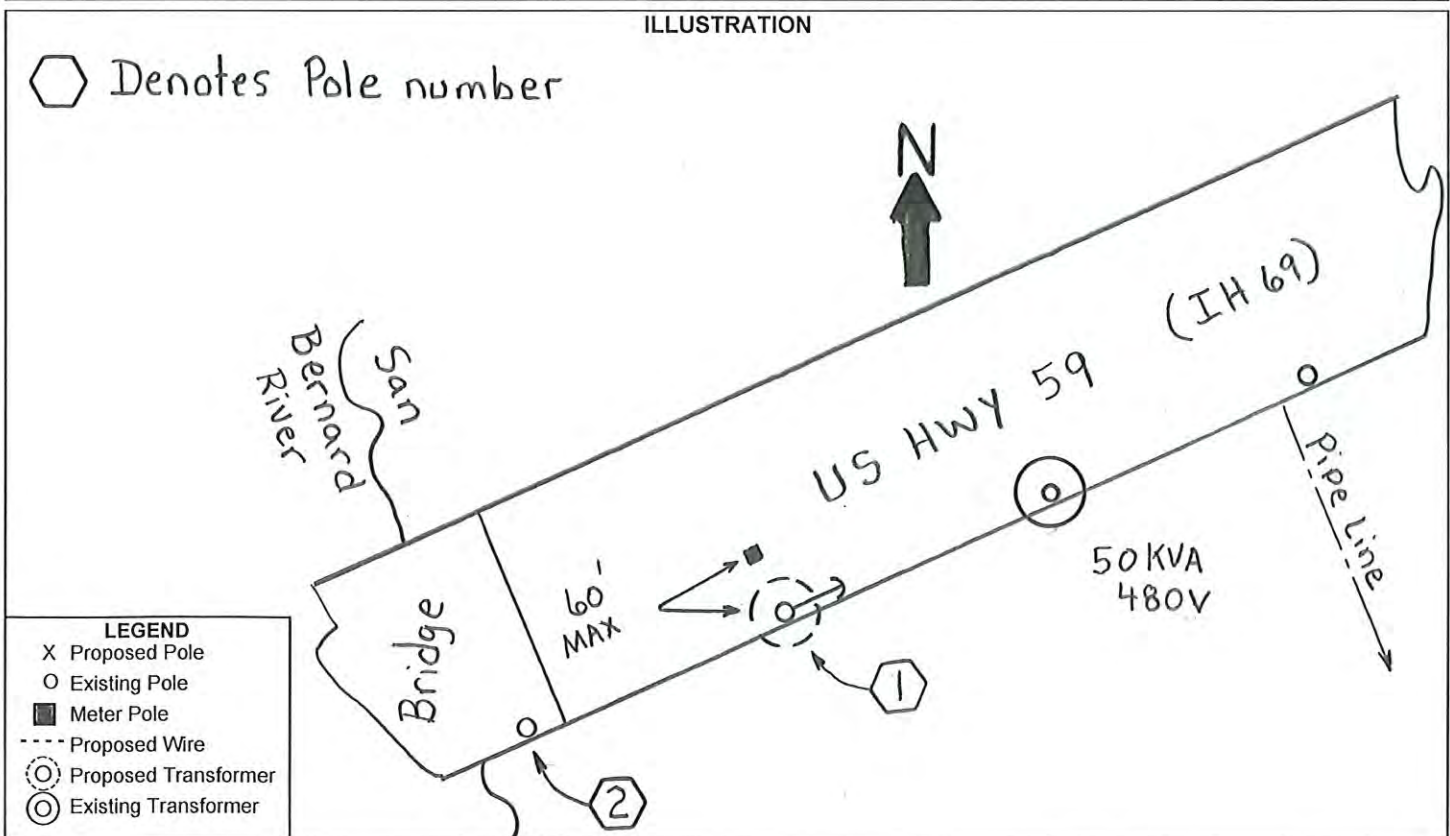

Taken from the CenterPoint Energy "Service Standards"

413 UNDERGROUND SERVICE LATERALS IN OVERHEAD AREAS

413.1 Requirements: It is necessary for Customers planning to install secondary underground service in Overhead Distribution Areas to consult the Service Consultant in the area to arrange for a Service Outlet Location and Data Statement as set forth in Article 203 and obtain the necessary Service Specifications for the installation. The Customer's underground riser conduit may be installed on CenterPoint Energy-poles where the pole is located on Customer's property or immediately adjacent in the street right-of-way or utility easement. Except for service transformer poles, customer riser conduit shall not be installed on poles with CenterPoint Energy power delivery equipment.

No more than four (4) conductors per phase and neutral shall be accepted per metered service (no more than 16 conductors per pole total for all services). Customer's conduit installed on poles shall be only rigid metal, intermediate metal, or PVC Schedule 80. When the underground service entrance conduit is PVC and the riser on the pole is rigid or intermediate metal conduit, the Customer or Customer's contractor shall install Supply Side Bonding Jumpers for all risers in accordance with requirements of the National Electrical Code.

Customer's service riser may be installed on a service pole if located on the Customer's property. Service poles will be provided ONLY if the standard service extension requires them. If service poles are not required for standard service extension, the Customer shall install and maintain a separate pole for the underground riser. **The maximum conduit riser attached directly to a pole shall not exceed one 3" conduit.** Larger conduit and multiple conduits may be installed on poles of sufficient strength, but they must be installed on stand-off brackets (See Illustration 13 – Conduit risers on stand-off brackets, next page). For non-wood poles, stand-off brackets may be banded to the pole with a minimum 3/4" Stainless Steel Band. Alternatively for fiberglass or ductile iron poles, bolt holes may be drilled with a carbide hole saw or carbide drill bit no closer than 4" apart. Unused drilled holes shall be plugged or covered. When the Company's poles with approved customer equipment attached need to be relocated or replaced, the customer is responsible for relocating all their equipment at their cost within 30 days of receipt of written notification.

Taken from the CenterPoint Energy “Service Standards”

422 METER POLE INSTALLATIONS

422.1 Requirements: A meter pole is required in those cases where suitable location, clearance, and anchorage as called for in Articles 403, 404 and 406 are not available on the Customer's premises. Even if the conditions set forth in Articles 403, 404 and 406 are satisfied, the Customer has the option to install a meter pole. Meter poles are installed and maintained by the customer at his expense and shall not be installed in utility easements. Meter poles required by the Company or at the Customer's discretion shall be a minimum 6" diameter wood pole or a steel pole of equivalent strength. The use of alternate types of meter poles must have Company approval before installation. All meter poles shall provide the point of attachment, clearances, and anchorage as described herein. The pole setting depth shall be a minimum of 4 ft., or 2 ft. plus 10% of the pole length, whichever is greater. Steel poles shall be truck accessible. The Company will not provide service to any customer owned steel pole that is not truck accessible. The customer must provide a readily accessible Service Disconnect at the meter pole.

422.3 Meter Seals: It is the practice of the Company to seal or lock all meters. Only the Company's agents and persons authorized by law are permitted to remove a Company seal or lock.

423 METER INSTALLATION SEQUENCE – 240V & BELOW SELF-CONTAINED

SERVICE – METER – SWITCH – FUSE – LOAD

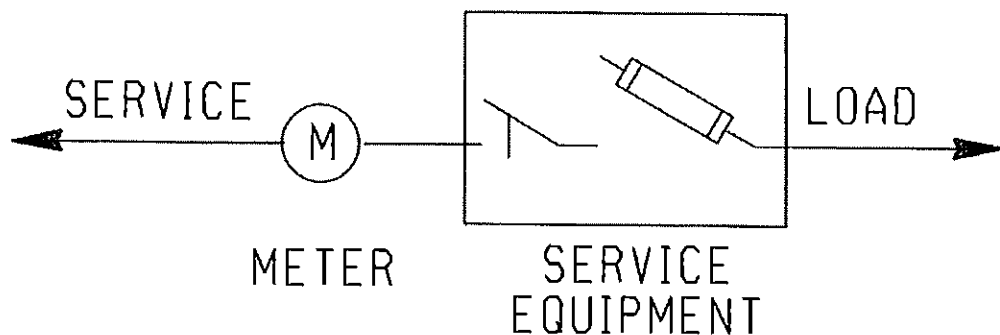

**TEXAS LAW AN ACT
TEXAS HEALTH AND SAFETY CODE TITLE 9**

CHAPTER 752 - Safety of persons engaged in activities in proximity of high voltage electric lines; restrictions

SECTION 001. DEFINITIONS

- (1) "High voltage" means more than 600 volts measured between conductors or between a conductor and the ground.
- (2) "Overhead line" means a bare or insulated electric conductor installed above ground but does not include a conductor that is de-energized and grounded or that is enclosed in a rigid metallic conduit.

SECTION 002. EXEMPTION FOR CERTAIN EMPLOYEES AND ACTIVITIES

(A) This chapter does not apply to the construction, reconstruction, operation, or maintenance by an authorized person of overhead electrical or communication circuits or conductors and their supporting structures and associated equipment that are part of a rail transportation system, an electrical generating, transmission, or distribution system or a communication system.

(B) In this section, "authorized person" means:

- (1) an employee of a light and power company, an electric cooperative, or a municipality working on his employer's electrical system;
- (2) an employee of a transportation system working on the system's electrical circuits;
- (3) an employee of a communication utility;
- (4) an employee of a state, county, or municipal agency that has authorized circuit construction on the poles or structures that belong to an electric power company, an electric cooperative, a municipal or transportation system, or a communication system;
- (5) an employee of an industrial plant who works on the plant's electrical system; or
- (6) an employee of an electrical or communications contractor who is working under the contractor's supervision.

SECTION 003. TEMPORARY CLEARANCE OF LINES

(A) A person, firm, corporation, or association responsible for temporary work or a temporary activity or function closer to a high voltage overhead line than the distances prescribed by this chapter must notify the operator of the line at least 48 hours before the work begins.

(B) A person, firm, corporation, or association may not begin the work, activity, or function under this section until the person, firm, corporation, or association responsible for the work, activity, or function and the owner or operator, or both, of the high voltage overhead line have negotiated a satisfactory mutual arrangement to provide temporary de-energization and grounding, temporary relocation or raising of the line, or temporary mechanical barriers to separate and prevent contact between the line and the material or equipment or the person performing the work, activity or function.

(C) The person, firm, corporation, or association responsible for the work, activity, or function shall pay the operator of the high voltage overhead line the actual expense incurred by the operator in providing the clearance prescribed in the agreement. The operator may require payment in advance and is not required to provide the clearance until the person, firm, corporation, or association responsible for the work, activity, or function makes the payment.

(D) If the actual expense of providing the clearance is less than the amount paid, the operator of the high voltage overhead line shall refund the surplus amount.

SECTION 004. RESTRICTION ON ALL ACTIVITIES NEAR LINES

(A) Unless a person, firm, corporation, or association effectively guards against danger by contact with the line as prescribed by Section 752.003, the person, firm, corporation, or association, either individually or through an agent or employee, may not perform a function or activity on land, a building, a highway, or other premises if at any time it is possible that the person performing the function or activity may:

- (1) move or be placed within six feet of a high voltage overhead line while performing the function or activity; or
- (2) bring any part of a tool, equipment, machine, or material within six feet of a high voltage overhead line while performing the function or activity.

(B) A person, firm, corporation, or association may not require an employee to perform a function or activity prohibited by Subsection (A).

SECTION 005. RESTRICTION ON OPERATION OF MACHINERY AND PLACEMENT OF STRUCTURES NEAR LINES

Unless a person, firm, corporation, or association effectively guards against danger by contact with the line as prescribed by Section 752.003, the person, firm, corporation, or association, either individually or through an agent or employee, may not:

- (1) erect, install, transport, or store all or any part of a house, building, or other structure within six feet of a high voltage overhead line;
- (2) install, operate, transport, handle, or store all or any part of a tool, machine, or equipment within six feet of a high voltage overhead line; or
- (3) transport, handle, or store all or any part of supplies or materials within six feet of a high voltage overhead line.

SECTION 006. RESTRICTION ON OPERATION OF CERTAIN MACHINERY OR EQUIPMENT

(A) A person, firm, corporation, or association, individually, through an agent or employee, or as an agent or employee, may not operate a crane, derrick, power shovel, drilling rig, hay loader, hay stacker, mechanical cotton picker, pile driver, hoisting equipment, or similar apparatus any part of which is capable of vertical, lateral, or swinging motion unless:

- (1) a warning sign is posted and maintained as prescribed by Subsections (B) and (C);
- (2) an insulated cage-type guard or protective device is installed about the boom or arm of the equipment, except a backhoe or dipper; and
- (3) each lifting line, if the equipment includes a lifting hook device, is equipped with an insulator link on the lift hook connection.

(B) The warning sign required by Subsection (A) (1) must be a weather-resistant sign of not less than five inches by seven inches with a yellow background and black lettering that reads:
"WARNING -- UNLAWFUL TO OPERATE THIS EQUIPMENT WITHIN TEN FEET OF HIGH VOLTAGE LINES."

(C) The warning sign must be legible at 12 feet and placed:

- (1) within the equipment so that it is readily visible to the equipment operator while at the equipment controls; and
- (2) on the outside of the equipment in the number and location necessary to make it readily visible to a mechanic or other person engaged in the work.

(D) Notwithstanding the distance limitations prescribed by Sections 752.004 and 752.005, unless a person, firm, corporation, or association effectively guards against danger by contact with the line as prescribed by Section 752.003, the person, firm, corporation, or association may not operate all or any part of a machine or equipment described by this section within 10 feet of a high voltage overhead line.

SECTION 007. CRIMINAL PENALTY

(A) A person, firm, corporation, or association or an agent or employee of a person, firm, corporation, or association commits an offense if the person, firm, corporation, association, agent, or employee violates this chapter.

(B) An offense under this section is punishable by a fine of not less than \$100 or more than \$1,000, confinement in jail for not more than one year, or both.

SECTION 008. LIABILITY FOR DAMAGES

If a violation of this chapter results in physical or electrical contact with a high voltage overhead line, the person, firm, corporation, or association that committed the violation is liable to the owner or operator of the line for all damages to the facilities and for all liability that the owner or operator incurs as a result of the contact.

Acts 1989, 71st Leg., ch. 678, § 1, eff. Sept. 1, 1989

Prior Laws:

Acts 1971, 62nd Leg., p. 76, ch. 41.

Vernon's Ann. Civ. St. art. 1436c, § 7(B).

This is only a part of the entire act. The complete act is available for review.



**SERVICE OUTLET LOCATION AND DATA STATEMENT
FOR ELECTRIC SERVICE**

6 of 7

PERMITTING ENTITY	PHONE NUMBER	LIFE OF PERMIT	TYPE RES	TYPE GEN
City of Alvin	281-388-4271	No limit*	E/M	E
City of Arcola	281-431-0606	6 months	F	F
City of Bayou Vista	409-935-8348	No limit*	E	E
City of Baytown	281-420-6537	90 days	E/M	O
City of Beach City	281-383-3180	6 months	E	E
City of Beasley	979-387-2775	90 days	E	E
BRAZORIA COUNTY	979-864-1295	1 year	F	F
City of Bellaire	713-662-8230	90 days	E	E
City of Brookshire	281-375-5050	6 months	E	E
City of Brookside Village	281-485-3048	90 days	E/M	E
City of Bunker Hill	713-467-9762	No limit*	E	E
CHAMBERS COUNTY	409-267-8392	90 days	F	F
City of Clear Lake Shores	281-334-2799	6 months	E	E
City of Clute	409-265-2541	6 months	E	E
City of Cove	281-573-8309	1 year	E	E
City of Danbury	979-922-1551	1 year	E	E
City of Dayton	936-258-2642	6 months	E	E
City of Deer Park	281-478-7270	1 year	E	O
City of Dickinson	281-337-6259	30 days	E	E
City of El Lago	281-326-1951	1 year	E	E
City of Freeport	979-233-3526	6 months	E/F/M	E/F
FORT BEND COUNTY	281-633-7502	1 year	F	F
City of Friendswood	281-996-3200	No limit*	E	E
City of Fulshear	281-346-1796	6 months	E	E
City of Galena Park	713-672-2556	90 days	E	E
City of Galveston	409-797-3660	6 months	E	E
GALVESTON COUNTY	409-770-5549	6 months	F	F
HARRIS COUNTY	713-956-3000	1 year	F	F
City of Hedwig Village	713-465-6009	6 months	E	E
City of Hillcrest	281-756-0577	6 months	E	E
City of Hillshire Village	713-973-1779	No limit*	E	E
City of Hitchcock	409-986-5591	6 months	E	E
City of Houston	832-394-8847	6 months	E/M	E
City of Humble	281-446-3061	90 days	E/M	E/O
City of Hunters Creek	713-465-2150	No limit*	E	E
City of Iowa Colony	281-369-2471	90 days	E	E
City of Jacinto City	713-674-8424	90 days	E	E
City of Jamaica Beach	409-737-1142	1 year	E	E
City of Jersey Village	713-466-2110	1 year	E/M	E
City of Jones Creek	409-233-1826	90 days	E	E
City of Katy	281-391-4830	180 days	E	E
City of Kemah	281-334-1611	6 months	E/M	E
City of Lake Jackson	979-415-2430	180 days	E	O
City of La Marque	409-938-9204	6 months	E/M	E
City of La Porte	281-471-5020	6 months	E/M	O
City of League City	281-554-1415	90 days	E	E



**SERVICE OUTLET LOCATION AND DATA STATEMENT
FOR ELECTRIC SERVICE**

PERMITTING ENTITY	PHONE NUMBER	LIFE OF PERMIT	TYPE RES	TYPE GEN
City of Magnolia	281-356-2266	1 year	E	E
City of Manvel	281-489-0630	1 year	E/M	E
City of Meadows Place	281-983-2950	1 year	E/M	E
City of Missouri City	281-403-8600	90 days	O	O
City of Mont Belvieu	281-576-2213	90 days	O	O
MONTGOMERY COUNTY	936-539-7836	1 year	F	F
City of Morgan's Point	281-471-2171	6 months	E	E
City of Nassau Bay	281-333-2108	6 months	E	E
City of Needville	409-793-4253	90 days	E/M	E
City of Oak Ridge North	281-292-4648	6 months	E	E
City of Old River Winfree	281-385-1735	90 days	E	E
City of Orchard	979-478-6893	180 days	E/M	O
City of Oyster Creek	979-233-0243	6 months	E	E
City of Pasadena	713-477-1511	90 days	E/M	O
City of Pattison	281-375-5550	6 months	E	E
City of Pearland	281-652-1638	6 months	E/M	O
City of Piney Point Village	713-782-0271	90 days	E	E
City of Quintana	979-233-0848	90 days	E	E
City of Richmond	281-232-6871	6 months	E/M	O
City of Richwood	979-265-2082	90 days	E	E
City of Rosenberg	1-832-595-3400	90 days	E/M	O
City of Santa Fe	409-925-6412	6 months	E/M	E
City of Seabrook	281-291-5668	6 months	E	E
City of Sealy	979-885-1669	90 days	E/M	E
City of Shoreacres	281-471-2253	1 year	E	E
City of South Houston	713-947-7700	6 months	E/M	O
City of Southside Place	713-668-2341	90 days	E	E
City of Spring Valley	713-465-8308	6 months	E	E
City of Stafford	281-261-3940	6 months	E/M	O
City of Sugar Land	281-275-2270	6 months	E/M	O
Village of Surfside Beach	979-233-1531	6 months	E	E
City of Taylor Lake Village	281-326-2843	90 days	E	E
City of Texas City	409-643-5946	30 days	E/M	E
City of Tomball	281-351-5484	6 months	E/M	E
Village of Tiki Island	409-935-1427	1 year	E	E
City of Waller	936-931-1042	1 year	E	E
City of Webster	281-338-2925	90 days	E	O
City of West University Place	713-662-5833	1 year	E	E
City of Weston Lakes	281-533-0907	90 days	F	F
City of Wharton	979-532-2491	6 months	E	E

* Duration of project

CODE TYPES

- E= All new meter Installation and wiring changes.
- O= For all MVI and Name changes including Mobile Homes
- F= All new permanent and/or temporary service.
- M= Mobile Homes

CenterPoint Energy Houston Electric, LLC
Applicable: Entire Service Area

CNP 8038

6.3 AGREEMENTS AND FORMS

6.3.1 FACILITIES EXTENSION AGREEMENT

This Facilities Extension Agreement is entered into by and between _____
Fort Bend County _____, herein
called "Retail Customer" and CenterPoint Energy Houston Electric, LLC, herein called
"Company" (hereinafter referred to as Agreement) for the construction, extension, installation,
modification, repair, upgrade, conversion, relocation, de-energization or removal of Company's
Delivery System, including temporary facilities (hereinafter referred to as facilities extension or
extension), as described herein.

This Agreement covers the facilities extension to Retail Customer location at _____
14703 US Highway 59 (IH 69 at San Bernard River) _____ **Layout #43**

The Company agrees to accept payment of _____ \$ 1,673.00 _____ Dollars
to be paid by the Retail Customer, as a Non-Refundable Construction Payment in connection
with the Retail Customer request to extend Company facilities to the above described location as
follows: _____ Permanent service beyond allowable distance. _____

_____ Cost to hang overhead transformer. _____

- Unless otherwise stated by Company in writing, the Non-Refundable Construction Payment amount above is valid for twelve months.

In consideration of said Non-Refundable Payment, to be paid to Company by Retail Customer prior to commencement of construction, Company agrees to install and operate lines and equipment necessary to distribute electric service to the identified location under the following General Conditions:

- Company shall at all times have title to and complete ownership and control over facilities installed by Company.
- Retail Customer must make satisfactory payment arrangements (if payment is required to extend Company facilities) and sign and return this Agreement before Company can proceed with the requested extension.

CenterPoint Energy Houston Electric, LLC
Applicable: Entire Service Area

CNP 8038

- Extension of service facilities is contingent on acquisition of all necessary easements and rights of way.

Nothing herein contained within this Agreement shall be construed as a waiver or relinquishment by Company of any right that it has or may hereafter have to discontinue service for or on account of default in the payment of any bill owing or to become owing thereafter for any other reason or cause stated in Company's Tariff.

This Agreement shall not be binding upon Company unless and until it is signed by an authorized representative of the Company.

CenterPoint Energy Houston Electric, LLC

Fort Bend County

Retail Customer

By Gabriel Gonzalez

By KP George

Gabriel Gonzalez

KP George

(name printed or typed)

(name printed or typed)

Title Service Area Manager

Title County Judge

Date 12/29/2025

Date January 12, 2026



Please make check payable to:
CenterPoint Energy

Attn: FTB SDAC

For FedEx/UPS: 935 Highway 90 ALT, Rosenberg, Tx 77471

For USPS: 935 Highway 90 ALT, Rosenberg, Tx 77471

INVOICE

Customer Info:

2/14/25

Name:	Fort Bend County				
Address:	14703 US Highway 59 - (IH 69 at San Bernard River) Layout #43				
City:	Beasley	State:	TX	Zip	77417
Phone:	281-238-3565				
Email:	Isabel.Roberts@fortbendcountytexas.gov				
CNP Representative:	Enrique Ramon	Phone:	281-341-4931		

Description		W/O #	Total
1	Permanent service beyond allowable distance	113634684	\$ 1,673.00
2			
3			
4			
5			
			\$1,673.00

**PLEASE MAIL PAYMENT TO THE ABOVE ADDRESS.
Processing of check may be delayed without the return of this invoice.**

Make all checks payable to: *CenterPoint Energy*

Please send a copy of this invoice along with the check. Charges good for 1 year from date of invoice.

Payment is required prior to release of construction work order

If you have any questions concerning this invoice, please contact your CNP Representative at number above.

Thank you for using CenterPoint Energy



**SERVICE OUTLET LOCATION AND DATA STATEMENT
FOR ELECTRIC SERVICE**

CUSTOMER Fort Bend County CCTV Facility No.44	DAY PHONE (972) 464-4817
SERVICE ADDRESS 815 Lum Rd Beasley, TX 77417	EVENING PHONE
MAILING ADDRESS	CELL PHONE
ELECTRICIAN	ELECTRICIAN'S PHONE

Dear Customer,

CenterPoint Energy Houston Electric, LLC is grateful to meet with you on, 09-13-2024 to discuss the requirements needed to provide you electric service. DATE

<ul style="list-style-type: none"> • CenterPoint Energy Construction Required? <input checked="" type="checkbox"/> YES <input type="checkbox"/> NO • The following steps must be complete prior to construction: <ul style="list-style-type: none"> <input checked="" type="checkbox"/> Pay any up-front contributions for non-standard service \$ <u>1,704.00</u> <input type="checkbox"/> Clear trees along extension route <input type="checkbox"/> Easement charges \$ _____ <input type="checkbox"/> Easement execution 	<p>To begin the process we request that you provide the following information:</p> <ul style="list-style-type: none"> <input type="checkbox"/> Site Plan and Elevation Plan: Hard Copies <input type="checkbox"/> Site Plan: Electronic Copy with XY Coordinates <input type="checkbox"/> One Line Diagram <input checked="" type="checkbox"/> Load Analysis <input type="checkbox"/> Easements Required-Recorded Warranty Deed Required <input type="checkbox"/> Specifications on Modular Metering Enclosure.
---	---

<table> <tr> <td>YES</td> <td>NO</td> <td></td> </tr> <tr> <td><input checked="" type="checkbox"/></td> <td><input type="checkbox"/></td> <td>Installation of meter pole or weather head (as located on sketch).</td> </tr> <tr> <td><input checked="" type="checkbox"/></td> <td><input type="checkbox"/></td> <td>Obtain city or county permit, if applicable. (See page 4 and 5)</td> </tr> <tr> <td><input checked="" type="checkbox"/></td> <td><input type="checkbox"/></td> <td>CenterPoint Energy will provide an ESI ID# for your account to the email address provided as your project progresses. Please do not request a meter until the construction is completed.</td> </tr> <tr> <td><input checked="" type="checkbox"/></td> <td><input type="checkbox"/></td> <td>Choose a Competitive Retailer - For listing, visit the website http://www.powertochoose.org or call 1-866-PWR-4-TEX (1-866-797-4839)</td> </tr> </table>	YES	NO		<input checked="" type="checkbox"/>	<input type="checkbox"/>	Installation of meter pole or weather head (as located on sketch).	<input checked="" type="checkbox"/>	<input type="checkbox"/>	Obtain city or county permit, if applicable. (See page 4 and 5)	<input checked="" type="checkbox"/>	<input type="checkbox"/>	CenterPoint Energy will provide an ESI ID# for your account to the email address provided as your project progresses. Please do not request a meter until the construction is completed.	<input checked="" type="checkbox"/>	<input type="checkbox"/>	Choose a Competitive Retailer - For listing, visit the website http://www.powertochoose.org or call 1-866-PWR-4-TEX (1-866-797-4839)
YES	NO														
<input checked="" type="checkbox"/>	<input type="checkbox"/>	Installation of meter pole or weather head (as located on sketch).													
<input checked="" type="checkbox"/>	<input type="checkbox"/>	Obtain city or county permit, if applicable. (See page 4 and 5)													
<input checked="" type="checkbox"/>	<input type="checkbox"/>	CenterPoint Energy will provide an ESI ID# for your account to the email address provided as your project progresses. Please do not request a meter until the construction is completed.													
<input checked="" type="checkbox"/>	<input type="checkbox"/>	Choose a Competitive Retailer - For listing, visit the website http://www.powertochoose.org or call 1-866-PWR-4-TEX (1-866-797-4839)													

Want to start gas service? Go to move.centerpointenergy.com/move or call 800-752-8036
To learn more about energy efficiency programs, please visit centerpointefficiency.com

CenterPoint Energy Houston Electric, LLC's target completion date to provide your construction requirements, per the working sketch, is a mutually agreed upon negotiated date by CenterPoint Energy and customer. *Please be aware our ability to meet the target completion date may be affected by weather, availability of construction crews and materials, ability to secure easements, and timely completion of your requirements (see above). In addition, as a condition to this service, you agree to comply with all of CenterPoint Energy standards, the National Electrical Code, the National Safety Code, all Occupational Safety and (OSHA) requirements, the International Building code and all local governing body codes.*

We appreciate the opportunity to do business with you and look forward to the successful completion of this project. Your signature below insures that both parties understand the requirements toward completion that will allow you electrical service. Thanks for your cooperation in this matter.

Sincerely,

Service Consultant

SERVICE CONSULTANT Bertha M. Silva <i>Gabriel Gonzalez</i>	PHONE NUMBER (281) 341-4908
ADDRESS 935 US 90 Alt Rosenberg, TX 77471	
E-MAIL ADDRESS bertha.silva@centerpointenergy.com	

CUSTOMER'S SIGNATURE <i>KP George</i>	DATE January 12, 2026
CUSTOMER'S PRINTED NAME KP George	

<table> <tr> <td>YES</td> <td>NO</td> <td></td> </tr> <tr> <td><input type="checkbox"/></td> <td><input checked="" type="checkbox"/></td> <td>Will Customer have Back-up Generation?</td> </tr> <tr> <td><input type="checkbox"/></td> <td><input checked="" type="checkbox"/></td> <td>Will Customer have Motor Greater than 250 HP?</td> </tr> </table>	YES	NO		<input type="checkbox"/>	<input checked="" type="checkbox"/>	Will Customer have Back-up Generation?	<input type="checkbox"/>	<input checked="" type="checkbox"/>	Will Customer have Motor Greater than 250 HP?
YES	NO								
<input type="checkbox"/>	<input checked="" type="checkbox"/>	Will Customer have Back-up Generation?							
<input type="checkbox"/>	<input checked="" type="checkbox"/>	Will Customer have Motor Greater than 250 HP?							
<p>APPLICABLE FORMS</p> <ul style="list-style-type: none"> <input type="checkbox"/> Power Quality <input type="checkbox"/> Primary Meter <input type="checkbox"/> Motor Start <input type="checkbox"/> Emergency Generation <input type="checkbox"/> Distributed Generation <input type="checkbox"/> Major UG Checklist 									

<p align="center">GENERAL SERVICE</p> <input type="checkbox"/> 1Ø 3W 120/208 <input checked="" type="checkbox"/> 1Ø 3W 120/240 <input type="checkbox"/> 3Ø 4W Δ 240V <input type="checkbox"/> 3Ø 4W Y 120/208V <input type="checkbox"/> 3Ø 4W Y 277/480V* *10 X 26 PT can mounted on 480V Service? <input type="checkbox"/> 3Ø 3W Δ 480V* *1-1/4" conduit connecting CT & PT can run? <input type="checkbox"/> Primary Metering Job <input type="checkbox"/> Major UG Job <input type="checkbox"/> Other: (Explain) _____ _____		<p align="center">SERVICE TYPE</p> <p>_____ FT² <input checked="" type="checkbox"/> All Electric <input type="checkbox"/> Gas & Electric</p> <p>Size Wire Pulled _____</p> <p>Cust's Load 1 Ø <u>5</u> +3 Ø _____ = <u>10</u> Total KVA</p> <p>Fault Current: Initial <u>6,200</u> Ultimate <u>99,300</u></p> <p align="center">Amperes RMS Symmetrical at <u>240</u> Volts</p>
<p align="center">CT CAN TYPE</p> <input type="checkbox"/> 320 Amp (self contained) <input type="checkbox"/> 30 X 42 <input type="checkbox"/> Bus Head Outdoor <input type="checkbox"/> Bus Head with CT Can <input type="checkbox"/> Stainless Steel Rack <input type="checkbox"/> Primary Job	<p align="center">CONDUITS ON POLE</p> <p align="center">Size of Conduit _____</p> <p align="center">No. of Conduits _____</p>	<p align="center">For Information Regarding:</p> <p align="center">CenterPoint Energy service standards visit www.centerpointenergy.com/electricservicestandards</p> <p align="center">For approvals on AUTOMATIC TRANSFER SWITCHES EMAIL SPECS TO ATs.Approvals@CenterPointEnergy.com</p>

COMMENTS OR NOTES
 Note: Customer may riser up existing Pole #1 or set Permanent Meter Pole as shown on sketch below.

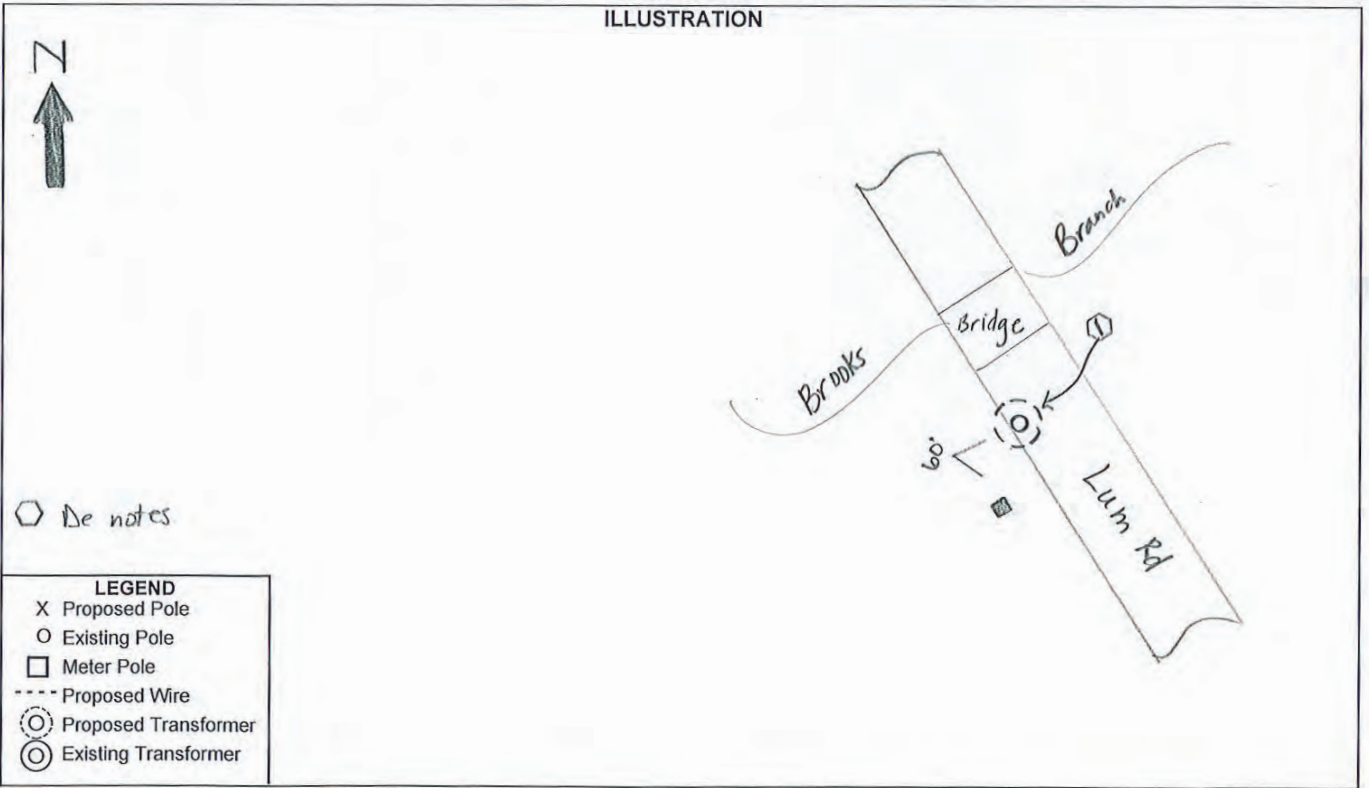

**TEXAS LAW AN ACT
TEXAS HEALTH AND SAFETY CODE TITLE 9**

CHAPTER 752 - Safety of persons engaged in activities in proximity of high voltage electric lines; restrictions

SECTION 001. DEFINITIONS

(1) "High voltage" means more than 600 volts measured between conductors or between a conductor and the ground.

(2) "Overhead line" means a bare or insulated electric conductor installed above ground but does not include a conductor that is de-energized and grounded or that is enclosed in a rigid metallic conduit.

SECTION 002. EXEMPTION FOR CERTAIN EMPLOYEES AND ACTIVITIES

(A) This chapter does not apply to the construction, reconstruction, operation, or maintenance by an authorized person of overhead electrical or communication circuits or conductors and their supporting structures and associated equipment that are part of a rail transportation system, an electrical generating, transmission, or distribution system or a communication system.

(B) In this section, "authorized person" means:

(1) an employee of a light and power company, an electric cooperative, or a municipality working on his employer's electrical system;

(2) an employee of a transportation system working on the system's electrical circuits;

(3) an employee of a communication utility;

(4) an employee of a state, county, or municipal agency that has authorized circuit construction on the poles or structures that belong to an electric power company, an electric cooperative, a municipal or transportation system, or a communication system;

(5) an employee of an industrial plant who works on the plant's electrical system; or

(6) an employee of an electrical or communications contractor who is working under the contractor's supervision.

SECTION 003. TEMPORARY CLEARANCE OF LINES

(A) A person, firm, corporation, or association responsible for temporary work or a temporary activity or function closer to a high voltage overhead line than the distances prescribed by this chapter must notify the operator of the line at least 48 hours before the work begins.

(B) A person, firm, corporation, or association may not begin the work, activity, or function under this section until the person, firm, corporation, or association responsible for the work, activity, or function and the owner or operator, or both, of the high voltage overhead line have negotiated a satisfactory mutual arrangement to provide temporary de-energization and grounding, temporary relocation or raising of the line, or temporary mechanical barriers to separate and prevent contact between the line and the material or equipment or the person performing the work, activity or function.

(C) The person, firm, corporation, or association responsible for the work, activity, or function shall pay the operator of the high voltage overhead line the actual expense incurred by the operator in providing the clearance prescribed in the agreement. The operator may require payment in advance and is not required to provide the clearance until the person, firm, corporation, or association responsible for the work, activity, or function makes the payment.

(D) If the actual expense of providing the clearance is less than the amount paid, the operator of the high voltage overhead line shall refund the surplus amount.

SECTION 004. RESTRICTION ON ALL ACTIVITIES NEAR LINES

(A) Unless a person, firm, corporation, or association effectively guards against danger by contact with the line as prescribed by Section 752.003, the person, firm, corporation, or association, either individually or through an agent or employee, may not perform a function or activity on land, a building, a highway, or other premises if at any time it is possible that the person performing the function or activity may:

(1) move or be placed within six feet of a high voltage overhead line while performing the function or activity; or

(2) bring any part of a tool, equipment, machine, or material within six feet of a high voltage overhead line while performing the function or activity.

(B) A person, firm, corporation, or association may not require an employee to perform a function or activity prohibited by Subsection (A).

SECTION 005. RESTRICTION ON OPERATION OF MACHINERY AND PLACEMENT OF STRUCTURES NEAR LINES

Unless a person, firm, corporation, or association effectively guards against danger by contact with the line as prescribed by Section 752.003, the person, firm, corporation, or association, either individually or through an agent or employee, may not:

(1) erect, install, transport, or store all or any part of a house, building, or other structure within six feet of a high voltage overhead line;

(2) install, operate, transport, handle, or store all or any part of a tool, machine, or equipment within six feet of a high voltage overhead line; or

(3) transport, handle, or store all or any part of supplies or materials within six feet of a high voltage overhead line.

SECTION 006. RESTRICTION ON OPERATION OF CERTAIN MACHINERY OR EQUIPMENT

(A) A person, firm, corporation, or association, individually, through an agent or employee, or as an agent or employee, may not operate a crane, derrick, power shovel, drilling rig, hay loader, hay stacker, mechanical cotton picker, pile driver, hoisting equipment, or similar apparatus any part of which is capable of vertical, lateral, or swinging motion unless:

(1) a warning sign is posted and maintained as prescribed by Subsections (B) and (C);

(2) an insulated cage-type guard or protective device is installed about the boom or arm of the equipment, except a backhoe or dipper; and

(3) each lifting line, if the equipment includes a lifting hook device, is equipped with an insulator link on the lift hook connection.

(B) The warning sign required by Subsection (A) (1) must be a weather-resistant sign of not less than five inches by seven inches with a yellow background and black lettering that reads:

"WARNING -- UNLAWFUL TO OPERATE THIS EQUIPMENT WITHIN TEN FEET OF HIGH VOLTAGE LINES."

(C) The warning sign must be legible at 12 feet and placed:

(1) within the equipment so that it is readily visible to the equipment operator while at the equipment controls; and

(2) on the outside of the equipment in the number and location necessary to make it readily visible to a mechanic or other person engaged in the work.

(D) Notwithstanding the distance limitations prescribed by Sections 752.004 and 752.005, unless a person, firm, corporation, or association effectively guards against danger by contact with the line as prescribed by Section 752.003, the person, firm, corporation, or association may not operate all or any part of a machine or equipment described by this section within 10 feet of a high voltage overhead line.

SECTION 007. CRIMINAL PENALTY

(A) A person, firm, corporation, or association or an agent or employee of a person, firm, corporation, or association commits an offense if the person, firm, corporation, association, agent, or employee violates this chapter.

(B) An offense under this section is punishable by a fine of not less than \$100 or more than \$1,000, confinement in jail for not more than one year, or both.

SECTION 008. LIABILITY FOR DAMAGES

If a violation of this chapter results in physical or electrical contact with a high voltage overhead line, the person, firm, corporation, or association that committed the violation is liable to the owner or operator of the line for all damages to the facilities and for all liability that the owner or operator incurs as a result of the contact.

Acts 1989, 71st Leg., ch. 678, [1, eff. Sept. 1, 1989

Prior Laws:

Acts 1971, 62nd Leg., p. 76, ch. 41.

Vernon's Ann. Civ. St. art. 1436c, [7(B).

This is only a part of the entire act. The complete act is available for review.



**SERVICE OUTLET LOCATION AND DATA STATEMENT
FOR ELECTRIC SERVICE**

PERMITTING ENTITY	PHONE NUMBER	LIFE OF PERMIT	TYPE RES	TYPE GEN
City of Alvin	281-388-4271	No limit*	E/M	E
City of Arcola	281-431-0606	6 months	F	F
City of Bayou Vista	409-935-8348	No limit*	E	E
City of Baytown	281-420-6537	90 days	E/M	O
City of Beach City	281-383-3180	6 months	E	E
City of Beasley	979-387-2775	90 days	E	E
BRAZORIA COUNTY	979-864-1295	1 year	F	F
City of Bellaire	713-662-8230	90 days	E	E
City of Brookshire	281-375-5050	6 months	E	E
City of Brookside Village	281-485-3048	90 days	E/M	E
City of Bunker Hill	713-467-9762	No limit*	E	E
CHAMBERS COUNTY	409-267-8392	90 days	F	F
City of Clear Lake Shores	281-334-2799	6 months	E	E
City of Clute	409-265-2541	6 months	E	E
City of Cove	281-573-8309	1 year	E	E
City of Danbury	979-922-1551	1 year	E	E
City of Dayton	936-258-2642	6 months	E	E
City of Deer Park	281-478-7270	1 year	E	O
City of Dickinson	281-337-6259	30 days	E	E
City of El Lago	281-326-1951	1 year	E	E
City of Freeport	979-233-3526	6 months	E/F/M	E/F
FORT BEND COUNTY	281-633-7502	1 year	F	F
City of Friendswood	281-996-3200	No limit*	E	E
City of Fulshear	281-346-1796	6 months	E	E
City of Galena Park	713-672-2556	90 days	E	E
City of Galveston	409-797-3660	6 months	E	E
GALVESTON COUNTY	409-770-5549	6 months	F	F
HARRIS COUNTY	713-956-3000	1 year	F	F
City of Hedwig Village	713-465-6009	6 months	E	E
City of Hillcrest	281-756-0577	6 months	E	E
City of Hillshire Village	713-973-1779	No limit*	E	E
City of Hitchcock	409-986-5591	6 months	E	E
City of Houston	832-394-8847	6 months	E/M	E
City of Humble	281-446-3061	90 days	E/M	E/O
City of Hunters Creek	713-465-2150	No limit*	E	E
City of Iowa Colony	281-369-2471	90 days	E	E
City of Jacinto City	713-674-8424	90 days	E	E
City of Jamaica Beach	409-737-1142	1 year	E	E
City of Jersey Village	713-466-2110	1 year	E/M	E
City of Jones Creek	409-233-1826	90 days	E	E
City of Katy	281-391-4830	180 days	E	E
City of Kemah	281-334-1611	6 months	E/M	E
City of Lake Jackson	979-415-2430	180 days	E	O
City of La Marque	409-938-9204	6 months	E/M	E
City of La Porte	281-471-5020	6 months	E/M	O
City of League City	281-554-1415	90 days	E	E



**SERVICE OUTLET LOCATION AND DATA STATEMENT
FOR ELECTRIC SERVICE**

PERMITTING ENTITY	PHONE NUMBER	LIFE OF PERMIT	TYPE RES	TYPE GEN
City of Magnolia	281-356-2266	1 year	E	E
City of Manvel	281-489-0630	1 year	E/M	E
City of Meadows Place	281-983-2950	1 year	E/M	E
City of Missouri City	281-403-8600	90 days	O	O
City of Mont Belvieu	281-576-2213	90 days	O	O
MONTGOMERY COUNTY	936-539-7836	1 year	F	F
City of Morgan's Point	281-471-2171	6 months	E	E
City of Nassau Bay	281-333-2108	6 months	E	E
City of Needville	409-793-4253	90 days	E/M	E
City of Oak Ridge North	281-292-4648	6 months	E	E
City of Old River Winfree	281-385-1735	90 days	E	E
City of Orchard	979-478-6893	180 days	E/M	O
City of Oyster Creek	979-233-0243	6 months	E	E
City of Pasadena	713-477-1511	90 days	E/M	O
City of Pattison	281-375-5550	6 months	E	E
City of Pearland	281-652-1638	6 months	E/M	O
City of Piney Point Village	713-782-0271	90 days	E	E
City of Quintana	979-233-0848	90 days	E	E
City of Richmond	281-232-6871	6 months	E/M	O
City of Richwood	979-265-2082	90 days	E	E
City of Rosenberg	1-832-595-3400	90 days	E/M	O
City of Santa Fe	409-925-6412	6 months	E/M	E
City of Seabrook	281-291-5668	6 months	E	E
City of Sealy	979-885-1669	90 days	E/M	E
City of Shoreacres	281-471-2253	1 year	E	E
City of South Houston	713-947-7700	6 months	E/M	O
City of Southside Place	713-668-2341	90 days	E	E
City of Spring Valley	713-465-8308	6 months	E	E
City of Stafford	281-261-3940	6 months	E/M	O
City of Sugar Land	281-275-2270	6 months	E/M	O
Village of Surfside Beach	979-233-1531	6 months	E	E
City of Taylor Lake Village	281-326-2843	90 days	E	E
City of Texas City	409-643-5946	30 days	E/M	E
City of Tomball	281-351-5484	6 months	E/M	E
Village of Tiki Island	409-935-1427	1 year	E	E
City of Waller	936-931-1042	1 year	E	E
City of Webster	281-338-2925	90 days	E	O
City of West University Place	713-662-5833	1 year	E	E
City of Weston Lakes	281-533-0907	90 days	F	F
City of Wharton	979-532-2491	6 months	E	E

* Duration of project

CODE TYPES

- E= All new meter Installation and wiring changes.
- O= For all MVI and Name changes including Mobile Homes
- F= All new permanent and/or temporary service.
- M= Mobile Homes

CenterPoint Energy Houston Electric, LLC
Applicable: Entire Service Area

CNP 8038

6.3 AGREEMENTS AND FORMS

6.3.1 FACILITIES EXTENSION AGREEMENT

This Facilities Extension Agreement is entered into by and between _____, herein called "Retail Customer" and CenterPoint Energy Houston Electric, LLC, herein called "Company" (hereinafter referred to as Agreement) for the construction, extension, installation, modification, repair, upgrade, conversion, relocation, de-energization or removal of Company's Delivery System, including temporary facilities (hereinafter referred to as facilities extension or extension), as described herein.

This Agreement covers the facilities extension to Retail Customer location at _____
815 Lum Rd Beasley, TX 77417

The Company agrees to accept payment of \$1,704.00 _____ Dollars to be paid by the Retail Customer, as a Non-Refundable Construction Payment in connection with the Retail Customer request to extend Company facilities to the above described location as follows: Permanent service beyond allowable distance. Cost to hang overhead transformer.

- Unless otherwise stated by Company in writing, the Non-Refundable Construction Payment amount above is valid for twelve months.

In consideration of said Non-Refundable Payment, to be paid to Company by Retail Customer prior to commencement of construction, Company agrees to install and operate lines and equipment necessary to distribute electric service to the identified location under the following General Conditions:

- Company shall at all times have title to and complete ownership and control over facilities installed by Company.
- Retail Customer must make satisfactory payment arrangements (if payment is required to extend Company facilities) and sign and return this Agreement before Company can proceed with the requested extension.

CenterPoint Energy Houston Electric, LLC
Applicable: Entire Service Area

CNP 8038

- Extension of service facilities is contingent on acquisition of all necessary easements and rights of way.

Nothing herein contained within this Agreement shall be construed as a waiver or relinquishment by Company of any right that it has or may hereafter have to discontinue service for or on account of default in the payment of any bill owing or to become owing thereafter for any other reason or cause stated in Company's Tariff.

This Agreement shall not be binding upon Company unless and until it is signed by an authorized representative of the Company.

CenterPoint Energy Houston Electric, LLC

By Gabriel Gonzalez

Gabriel Gonzalez
(name printed or typed)

Title Service Area Manager

Date 12/29/2025

Retail Customer

By KP George

KP George
(name printed or typed)

Title County Judge

Date January 12, 2026



Please make check payable to:
CenterPoint Energy

Attn: Fort Bend PAC
935 US 90 Alt Rosenberg, TX 77471

INVOICE

Customer Info:

10/23/24

Name:	Fort Bend County CCTV No. 44				
Address:	815 Lum Rd				
City:	Beasley	State:	Texas	Zip:	77417
Phone:	972-464-4817				
Email:					
CNP Representative:	Bertha Silva				281-341-4908

	Description	W/O #	Total
1	In aid of Construction	114272959	\$ 1,704.00
2			
3			
4			
5			
			\$1,704.00

**PLEASE MAIL PAYMENT TO THE ABOVE ADDRESS.
Processing of check may be delayed without the return of this invoice.**

Make all checks payable to: *CenterPoint Energy*

Please send a copy of this invoice along with the check. Charges good for 1 year from date of invoice.

Payment is required prior to release of construction work order

If you have any questions concerning this invoice, please contact your CNP Representative at number above.

Thank you for using CenterPoint Energy