

STATE OF TEXAS §
 §
 COUNTY OF FORT BEND §

**ADDENDUM TO PERFORMANCE TRUCK'S QUOTE
 (Buy Board Contract No. 723-23)**

THIS ADDENDUM is entered into by and between Fort Bend County, ("County"), a body corporate and politic under the laws of the State of Texas, on behalf of the Road and Bridge Department, and Performance Truck ("Performance Truck"), a company authorized to conduct business in the State of Texas (hereinafter collectively referred to as "parties").

WHEREAS, the County desires that Performance Truck provide products and/or services for Fort Bend County in accordance with the Performance Truck's Quotes (Quote Numbers QUO-1130151-M7F0C4, QUO-1130145-N7L4R4, QUO-1130148-S1V9H6, and QUO-1130146-D5K0N4, collectively hereinafter the "Quote") dated September 25, 2025 attached hereto as Exhibit "A," subject to the changes herein, and in accordance with the Buy Board Contract No. 723-23, incorporated by reference herein; and

WHEREAS, the County desires that Performance Truck provide Three (3) T880 Dump Trucks, Two (2) T380 Dump Trucks, One (1) T880 Haul Truck, and One (1) T480 Grapple Truck; and

WHEREAS, Performance Truck represents that it is qualified and desires to provide such products and/or services; and

WHEREAS, the parties wish to utilize the Buy Board Cooperative Purchasing Contract No. 723-23 – for Medium and Heavy-Duty Trucks, Parts, and Maintenance Repair Services, which is incorporated fully by reference only, for the purchase of the specified products and/or services; and

WHEREAS, this Agreement is not subject to competitive bidding requirements under Section 262.023 of the Texas Local Government Code because this Agreement is pursuant to a Cooperative Purchasing Program in accordance with Chapter 271 of the Texas Local Government Code; and

NOW, THEREFORE, in consideration of the mutual covenants and conditions set for the below, the following changes are incorporated as if a part of the original Agreement:

1. **Recitals.** The recitals set forth above are incorporated herein by reference and made a part of this Agreement.
2. **Scope of Services.** Subject to the changes herein, Performance Truck shall provide products and/or services for Fort Bend County in accordance with the Quote, attached hereto as Exhibit "A, and in accordance with the Buy Board Contract No. 723-23, both of which are incorporated herein by reference.

3. **Compensation and Payment.** Performance Truck's fees shall be calculated at the rates set forth in the attached Exhibit A. County shall pay each approved invoice within thirty (30) calendar days of receipt of invoice. County reserves the right to withhold payment pending verification of satisfactory work performed.
4. **Time of Performance.** The Agreement shall be effective upon execution by County. The time for performance under this Agreement shall begin with receipt of the Notice to Proceed. Performance Truck shall provide the specified products to County as described in the attached Exhibit "A."
5. **Taxes.** County is a body corporate and politic under the laws of the State of Texas and claims exemption from sales and use taxes. A copy of a tax-exempt certificate will be furnished upon request.
6. **Limit of Appropriation.** Performance Truck clearly understands and agrees, such understanding and agreement being of the absolute essence of this Agreement, that County shall have available the total maximum sum of One Million Five Hundred Forty-Four Thousand, One Hundred Fifty-Five and 00/100 dollars (\$1,544,155.00), specifically allocated to fully discharge any and all liabilities County may incur. Performance Truck does further understand and agree, said understanding an agreement also being of the absolute essence of this Agreement, that the total maximum compensation that Performance Truck may become entitled to and the total maximum sum that County may become liable to pay to Performance Truck shall not under any conditions, circumstances, or interpretations thereof exceed One Million Five Hundred Forty-Four Thousand, One Hundred Fifty-Five and 00/100 dollars (\$1,544,155.00).
7. **Non-appropriation.** It is specifically understood and agreed that in the event no funds or insufficient funds are appropriated by Fort Bend County under this Agreement, Fort Bend County shall notify all necessary parties that this Agreement shall thereafter terminate and be null and void on the last day of the fiscal period for which appropriations were made without penalty, liability or expense to Fort Bend County.
8. **Modifications.** The parties may not amend or waive this Agreement, except by a written agreement executed by both parties.
9. **Confidential Information.** Performance Truck expressly acknowledges that County is subject to the Texas Public Information Act, Tex. Gov't. Code Ann. §§ 552.001 *et seq.*, as amended, and notwithstanding any provision in the Agreement to the contrary, County will make any information related to the Agreement, or otherwise, available to third parties in accordance with the Texas Public Information Act. Any proprietary or confidential information marked as such provided to County by Performance Truck shall not be disclosed to any third party, except as directed by the Texas Attorney General in response to a request for such under the Texas Public Information Act, which provides for notice to the owner of such marked information and the opportunity for the owner of

such information to notify the Attorney General of the reasons why such information should not be disclosed.

10. **Indemnity.** The parties agree that under the Constitution and laws of the State of Texas, County cannot enter into an agreement whereby County agrees to indemnify or hold harmless another party; therefore, all references of any kind to County defending, indemnifying, holding or saving harmless Performance Truck for any reason are hereby deleted.
11. **Attorney Fees.** County does not agree to pay any and/or all attorney fees incurred by Performance Truck in any way associated with the Agreement.
12. **Arbitration.** County does not agree to submit disputes arising out of the Agreement to binding arbitration. Therefore, any references to binding arbitration or the waiver of a right to litigate a dispute are hereby deleted.
13. **Applicable and Governing Law.**
 - a. The laws of the State of Texas govern all disputes arising out of or relating to this Agreement. The parties hereto acknowledge that venue is proper in Fort Bend County, Texas, for all legal actions or proceedings arising out of or relating to the Agreement and waive the right to sue or be sued elsewhere. Nothing in the Agreement shall be construed to waive the County's sovereign immunity.
 - b. As required by Chapter 2271, Government Code, Performance Truck verifies that if Performance Truck employs ten (10) or more full-time employees and this Agreement has a value of \$100,000 or more, Performance Truck hereby verifies that it does not boycott Israel and will not boycott Israel through the term of this Agreement.
 - c. By signature below, Performance Truck represents pursuant to Section 2252.152 of the Texas Government Code, that Performance Truck is not listed on the website of the Comptroller of the State of Texas concerning the listing of companies that are identified under Section 806.051, Section 807.051 or Section 2253.153.
14. **Human Trafficking.** BY ACCEPTANCE OF CONTRACT, PERFORMANCE TRUCK ACKNOWLEDGES THAT FORT BEND COUNTY IS OPPOSED TO HUMAN TRAFFICKING AND THAT NO COUNTY FUNDS WILL BE USED IN SUPPORT OF SERVICES OR ACTIVITIES THAT VIOLATE HUMAN TRAFFICKING LAWS.
15. **Conflict.** All terms and conditions of the Agreement not modified herein remain in full force and effect. In the event there is a conflict between this Addendum and the attached Exhibit(s), this Addendum controls to the extent of the conflict. In the event there is a conflict between this Addendum and Buy Board Contract No. 723-23, the Buy Board Contract shall control to the extent of the conflict.

16. Understanding, Fair Construction. By execution of this Addendum, the parties acknowledge that they have read and understood each provision, term and obligation contained in this Addendum. This Addendum, although drawn by one party, shall be construed fairly and reasonably and not more strictly against the drafting party than the nondrafting party.

17. Electronic and Digital Signatures. The parties to this Agreement agree that the electronic and/or digital signatures of the parties included in this Agreement are intended to authenticate this writing and to have the same force and effect as the use of manual signatures.

[REMAINDER OF PAGE INTENTIONALLY LEFT BLANK]

[EXECUTION PAGE FOLLOWS]

IN WITNESS WHEREOF, this Addendum is signed, accepted, and agreed to by all parties by and through the parties or their agents or authorized representatives. All parties hereby acknowledge that they have read and understood this Addendum and the attachments and exhibits hereto. All parties further acknowledge that they have executed this legal document voluntarily and of their own free will.

FORT BEND COUNTY

KP George
KP George, County Judge

December 18, 2025
Date

REVIEWED:

Scott Wiegat
Scott Wiegat,
Fort Bend County Road Commissioner

PERFORMANCE TRUCK

[Signature]
Authorized Agent - Signature

Dan Yeager
Authorized Agent-Printed Name

CEO
Title

12/18/25
Date

AUDITOR'S CERTIFICATE

I hereby certify that funds in the amount of \$ 1,544,155.00 are available to pay the obligation of Fort Bend County within the foregoing Agreement.

[Signature]
Robert Ed Sturdivant, County Auditor

EXHIBIT A

Performance Truck Quotes
(dated 9/25/2025)

PERFORMANCE TRUCK - BROOKSHIRE

34211 Katy Freeway, Brookshire, 81 77423

Phone: (281) 239-7383

BUYER'S ORDER

Date Prepared: 09-26-2025		Delivery Date: 02-28-2026		Salesman: Drew Vest		Branch: Brookshire	
Purchaser: Fort Bend County				Telephone: 281-342-4513 Fax:			
Mailing Address: 301 Jackson City: Richmond State: TX Zip: 77469						County: Fort Bend	
Physical Address: 201 Payne Lane City: Richmond State: TX Zip: 77469						County: Fort Bend	
Description: NEW 2026 KENWORTH T880				Email Address: russell.hurta@fortbendcountytx.gov			
Mileage:		Color: L0436EY Sierra Blue		NOTE: Buy Board Contract #723-23			
VIN: TO ORDER Comments: See attached vehicle summary, quote ID # QUO-1130151-M7F0C4.							
Purchaser's Agent: Russell Hurta			Title: GM Fleet Operations			License Type: Commercial Account # FBC	

LICENSE - TITLE INFORMATION

Months: 12	Tractor:	Truck: X	Trailer:	Body Type: N/A	Color: BLU	Tons:	GCW: 54600
Apportioned:	IMC #	Combination:	Com'l: X	Token Trailer:	Gas:	Diesel: X	

INSURANCE INFORMATION

AGENCY:	
NAME:	PHONE:

LIEN INFORMATION

NAME:	LIEN DATE:
ADDRESS:	PHONE:
CITY, STATE, ZIP:	
COMMENTS:	
AMOUNT:	NAME:

ADDITIONAL INFORMATION

Proposal is per truck for ASAP build. Estimated delivery date to be confirmed at time of order.	
Buy Board Contract #723-23	
New Kenworth T880 Dump Truck	
Cummins X15 Engine (450 HP) / Allison 4000RDS Trans	
Truck Fabricators - 15ft Dump Body w/ Electric Tarp installed	
Extended warranties include coverage up to 5 years or 100k miles on Basic Vehicle, Engine and Aftertreatment.	

SELLING PRICE*	206,135.00
ACCESSORIES	-
CASH PRICE W/ACCESS.	206,135.00
TRADE IN ALLOWANCE	-
NET CASH DIFFERENCE	206,135.00
FEDERAL RETAIL EXCISE TAX	-
NET PRICE	206,135.00
STATE SALES TAX	-
LICENSE MO. & FEE	-
TITLE FEE (INCLUDES \$5 TAG FEE)	10.00
COMMERCIAL INSPECTION FEE	-
DEALER'S INVENTORY TAX	-
DOCUMENTARY FEE**	75.00
EXTENDED WARRANTY	5,655.00
SUBTOTAL	211,875.00
BALANCE OWED ON TRADE	-
SUBTOTAL	211,875.00
PREPAYMENT	-
BALANCE DUE UPON DELIVERY	211,875.00

DISCLAIMER OF WARRANTY

Any warranties on the products sold hereby are those made by the manufacturer. The seller, CLEVELAND MACK SALES, INC., PERFORMANCE TRUCK OR PERFORMANCE TRAILER, hereby expressly disclaims all warranties, either express or implied, including any implied warranty of merchantability or fitness for a particular purpose, and CLEVELAND MACK SALES, INC., PERFORMANCE TRUCK OR PERFORMANCE TRAILER neither assumes nor authorizes any other person to assume for it any liability in connection with the sale of said products.

* PRICE IS SUBJECT TO INDUSTRY AND ENVIRONMENTAL COST IMPACTS BEYOND THE CONTROL OF PERFORMANCE TRUCK

** A DOCUMENTARY FEE IS NOT AN OFFICIAL FEE. A DOCUMENTARY FEE IS NOT REQUIRED BY LAW, BUT MAY BE CHARGED TO BUYERS FOR HANDLING DOCUMENTS RELATING TO THE SALE. A DOCUMENTARY FEE MAY NOT EXCEED A REASONABLE AMOUNT AGREED TO BY THE PARTIES. THIS NOTICE IS REQUIRED BY LAW.

Vehicle(s) are subject to prior sale and will not be held more than five working days.

PURCHASER _____

THIS ORDER NOT BINDING UNTIL ACCEPTED BY DEALER.

SALESPERSON _____

ACCEPTED BY _____



PERFORMANCE TRUCK - CLEVELAND (C359)
 1287 HIGHWAY 59 NORTH
 CLEVELAND, Texas 77328

FORT BEND COUNTY
 201 PAYNE LANE
 RICHMOND, Texas 77469
 United States of America

Drew Vest
 Cell Phone: 281-610-8007
 Office Phone: 713-844-7111
 Email: avest@performancetruck.com

RUSSELL HURTA
 Email:
 russell.hurta@fortbendcountytexas.gov

Vehicle Summary

	Unit		Chassis	
Model:	T880 Series Conventional	Fr Axle Load (lbs):		14600
Type:	FULL TRUCK	Rr Axle Load (lbs):		40000
Description 1:	T880 DUMP TRK	G.C.W. (lbs):		54600
Description 2:	2026 Budget			
	Application	Road Conditions:		
Intended Serv.:	Construction: Vehicles used in the	Class A (Highway)		88
	cons			
Commodity:	Gravel/Crushed Rock/Sand	Class B (Hwy/Mtn)		10
		Class C (Off-Hwy)		2
		Class D (Off-Road)		0
	Body	Maximum Grade:		6
Type:	End Dump	Wheelbase (in):		194
Length (ft):	15	Overhang (in):		62
Height (ft):	13.5	Fr Axle to BOC (in):		74
Max Laden Weight (lbs):	5000			
		Cab to Axle (in):		120
		Cab to EOF (in):		182
	Trailer	Overall Comb. Length (in):		304.5
No. of Trailer Axles:	0			
Type:				
Length (ft):	0			
Height (ft):	0			
Kingpin Inset (in):	0			
Corner Radius (in):	0			
	Restrictions			
Length (ft):	120			
Width (in):	102			
Height (ft):	13.5			

Special Req.
 U.S. Domestic Registry, 50-state.

Approved by: _____

Date: _____

Note: All sales are F.O.B. designated plant of manufacture.

Std/ Opt	Description	Weight
Model		
S	T880 Series Conventional	15,549
S	T880	0
O	Chassis Operation Will Not Incl. Stationary application. Stationary operation is defined as running the engine under load while stationary at a substantial fraction of engine gross horsepower (60% or greater) for an extended period of time (longer than 5 - 10 minutes).	0
O	CARB Low NOX Omnibus Registration Guidelines Dealer/Customer acknowledges that this vehicle is NOT intended for registration or domicile/primary use in the State of California.	0
O	EPA Clean Idle Label - Cummins Engines	0
S	Non-Sleeper w/ Rear Axle Capacity less than 59K.	0
O	State of Registry: Texas	0
Engine & Equipment		
O	Cummins X15 450V 450@1900 1650@900, 2024 with Intebrake, Productivity Series N09420 C333 0.....Reserve Speed Limit Offset (N09380 C334 0.....Maximum Cycle Distance (C334 N09360 C400 252...Reserve Speed Function Reset N09200 C399 100...Standard Maximum Speed Limit N09400 C401 10.....Maximum Active Distance (C40 N09220 C402 0.....Expiration Distance (C402) N09540 C395 0.....Expiration Distance (C395) N09260 C121 68....Maximum Accelerator Pedal Ve N09440 C234 YES...Engine Protection Shutdown (N09460 C231 NO....Gear Down Protection (C231) N09580 C133 5.....Timer Setting (C133) N09680 C233 NO....Idle Shutdown Manual Ovrul N09480 C132 1400..Max PTO Speed (C132) N09300 C128 68....Maximum Cruise Speed (C128) N09500 C239 NO....Cruise Control Auto Resume (N09520 C238 NO....Auto Engine Brake in Cruise N09240 C209 100...Hard Maximum Speed Limit (C2 N09780 C190 80....High Ambient Temperature Thr N09740 C188 40....Low Ambient Temperature Thre N09760 C189 60....Intermediate Ambient Tempera N09720 C382 YES...Enable Hot Ambient Automatic N09600 C396 YES...Enable Impending Shutdown Wa N09620 C397 60....Timer For Impending Shutdown N09640 C206 35....Engine Load Threshold (C206) N09560 C225 YES...Enable Idle Shutdown Park Br	470
O	EPA Emissions Warranty Engine	0

Std/ Opt	Description	Weight
S	PremierSpec	0
O	Gearing Analysis: Balance power/economy blend results.	0
O	Customer's Typical Operating Spd: 65 MPH	0
O	EWI Tracking - A2 Engine Module Chassis	0
	RegistrationYear Year of Registration: 2025	0
O	Effective VSL Setting NA	0
O	Engine Idle Shutdown Timer Disabled	0
O	Eff EIST NA Expiration Miles Use only with MX and Cummins engines	0
O	Air Compressor: Cummins 18.7 CFM, Naturally Aspirated for Cummins X15 and X15N engines	0
S	Air Cleaner: Composite Firewall Mounted PACCAR or Cummins Engines	0
O	Pre-Cleaner Mounted in the Hood Plenum	0
O	Fan Hub: Horton 2-Speed for X15/X15N	0
S	Cooling module: 1330 square inches. Includes aluminum radiator core, aluminum charge air cooler, translucent surge tank and washer bottle, silicone hoses, and extended life coolant.	0
O	Bug Screen: Between Hood & Grille	2
S	EXH: Single Can 2024 RH Under with RH Side-of-Cab Vertical Tailpipe	0
O	Tailpipe: 5 in. single 24 in. 45 degree curved.	-3
O	Fuel Filter:PACCAR Standard Service Interval Fuel/Water Separator. 2017 and Later Emissions	0
S	Run Aid:Fuel Heat *For Fuel Filter	0
O	Start Aid:None *For Fuel Filter	0
O	Kenworth Fuel Cooler Required for Cummins engines with a single fuel tank. Required for PACCAR MX-13 engine with a single fuel tank and stationary use: High RPM, low vehicle speed, sustained for longer than 1 hour. Optional for all other applications.	6
S	Alternator: PACCAR HDS 160 AMP Brushed	0
O	Batteries: 2 PACCAR GP31 Threaded Post (1000) 2000 CCA starting.	-59

Std/ Opt	Description	Weight
O	Mitsubishi 105P55 12V Starter with Cummins and PX PACCAR 12 volt electrical system. W/ centralized power distribution incorporating plug-in style relays. Circuit protection for serviceability, 12-volt light system w/circuit protection circuits number & color coded. Only for Cummins or PX engines.	0
O	Battery Disconnect Switches 2, Mounted On Battery Box.	2
S	12V Low Voltage Disconnect for Battery Protection	0
O	Jump Start Terminals Under Hood.	12
S	Remote PTO/Throttle, 12-Pin, Engine Bay Remote Control Provision	0

Transmission & Clutch

O	Transmission: Allison 4000RDS 6-speed, With PTO drive gear. No retarder. 6th Generation controls. For vocational applications. Includes shift control, transmission oil temperature gauge, oil level sensor & heat exchanger. Transynd transmission fluid is standard on all Allison 1000, 2000, 3000 & 4000 series transmissions.	478
O	Driveline: 2 Dana 1810 Heavy-Duty 1 Centerbearing *Heavy duty is 1810HD series.	83
O	Torque Converter Included W/ Allison Transmission.	0
O	Pushbutton Control Center Console Mounted. Class 8 with Allison Transmission.	0
O	Allison Fuel Sense: Delete	0
O	J1939 Park Brake Auto Neutral	0
O	Allison Neutral at Stop	0
O	Rear Transmission Support Springs for transmission PTO applications are required to ensure that engine flywheel housings are not overloaded when transmission PTO's are installed.	0
O	Customer Installed Transmission PTO in the LH Mounted position (8 o'clock) for Allison 3000 & 4000 transmissions.	0

Front Axle & Equipment

O	Dana Spicer D-1461W Front Axle rated 14.6K 3-1/2in. drop, wide track for use with air disc brake only.	-122
O	Front Brakes: 14.6K Meritor EX+L Optimized air disc brakes.	0
O	U-Shaped Rotor for Meritor Air Disc Brakes.	0
O	Front Hub: Iron Hub Pilot 14,600 lbs. 11-1/4 in. bolt circle. For use w/ air disc brakes. Consider wheelguards (5850002) w/ aluminum wheels.	48
S	ConMet PreSet Plus Hub Package; Front Axle.	0

<i>Std/ Opt</i>	<i>Description</i>	<i>Weight</i>
S	Hubcap: Front Vented.	0
S	Slack Adjusters Included W/ Front Axle or Brakes. Also use with disc brakes.	0
O	Front Springs: Taperleaf 14.6K W/ Shock Absorbers 2-leaf. With maintenance-free elastomer spring pin bushings. Standard with rubber pins. Not available on W900L or W900S.	-101
O	Single Power Steering Gear: 16K TRW TAS85	-35
O	Delete Standard Power Steering Cooler.	-11
Rear Axle & Equipment		
O	Dual Meritor MT40-14x4 Hypoid Rear Axle rated at 40K, with heavy-wall housing. Tandem rear axles.	-411
O	Rear Axle Ratio - 4.33.	0
O	Dual Rear Brakes 16-1/2x7 in. to 46K; Meritor Q- plus-extended service S-cam.	-24
O	Dual Rear Brake Drums: Cast. For use with 16.5X7" or 16.5X8.625" brake.	208
S	Dual Rear Hubs: Aluminum Hub Pilot 46K; 11.25" bolt circle. Requires "R" series outer ends.	0
S	ConMet PreSet Plus Hub Package; Dual Rear Axle.	0
O	Tandem Rear Axle Automatic Slack Adjusters. For use with drum brakes.	0
O	Spring Brake: 3030 Long Stroke Dual 30 Square inches travel. For drum brakes. Helps keep brakes in adjustment longer.	88
O	Bendix 4S/4M Anti-Lock Brake System W/ Air traction control (ATC).	2
O	Interaxle Driveline:1 Dana 1710 Series Tandem Rear Axles Only.	-1
O	Rear suspension: Tandem Reyco 102 40K. 4-spring multileaf & 52 in. axle spacing. Steel crossmembers & gussets. Unladen Height: 10.8 in. Laden Height: 9.2 in.	116
O	Delete Standard Heavy-Duty Air Springs for Rear suspension.	-28
Tires & Wheels		
O	Front tires: Goodyear G291 315/80R22.5 20PR. 42.3 in. diameter, all position, 19.7 in. SLR.	-108
O	Rear tires: Continental HDL3 LTL 11R24.5 16PR	200
O	Rear Tire Quantity: 8	0
O	Front Wheel: Kenworth 7-spoke 88U68	-40

<i>Std/ Opt</i>	<i>Description</i>	<i>Weight</i>
	22.5x8.25 aluminum with Ultra One high polish finish, hub-pilot mount. 7300lb. maximum rating. Level 1 finish. Air disc brake compatible.	
O	Rear Wheel: Kenworth 7-spoke 98U68 24.5x8.25 aluminum with Ultra One High Polish finish, hub-pilot mount. 7300lb. maximum rating. Air disc brake compatible. Code is priced per pair of wheels.	-84
O	Rear Wheel/Rim Quantity: 8	0

Frame & Equipment

O	Frame Rails: 10-5/8 x 3-1/2 x 5/16 in. Steel to 285 in. to 336 in. Truck frame weight is 2.91 lb.-in. per pair of rails. Section modulus is 14.80, RBM is 1,776,000 in-lbs per rail. Frame rail availability may be restricted based upon application, axle/suspension capacity, fifth wheel setting, or component/dimensional specifications. The results of the engineering review may result in a change to the requested frame rail. If a change is required Kenworth Application Engineering will advise the dealer of the appropriate material specification for a substitute rail.	102
O	Bumper: Tapered Polished Aluminum Channel. Requires a bumper setting code.	-6
S	48.5 in. Bumper Setting. Requires a Bumper Code.	0
O	Front Tow Hook: Center Mounted, Cast. Requires iron front drive brackets.	28
O	Brackets: Iron Front Spring Drive. Included with front spring capacity of 16,000 lbs or greater; code not required.	47
O	Custom Frame Layout: 3-4 Chassis CFL A/D: MOUNT AIR DRYERS CLEAR OF TRANSMISSION AREA	0
O	Battery Box Cantilever Aluminum BOC with fiberglass cover.	8
O	Battery Box Location: RH Side.	15
S	C5, T6, T8 diamond plate cover and black end plates with access step for right hand under DPF/SCR or CNG. For T8, use extended length non-polished battery box on opposite rail to match the length of under cab components. End plates will be painted standard black frame color.	0
O	Final End-of-Frame Cut-Off Dimension Will be modified to less than or equal to 45 in.	0
S	Rear Mudflap Arms: Betts B-25 Standard-Duty, straight. Includes B1732 mounting brackets as standard.	0
S	Rear Mudflap Shields: White Plastic Antisail W/ Kenworth logo.	0
O	Quarter Fenders: Stainless Steel W/ Painted Steel brackets, single post mounted.	55
S	Square End-of-Frame W/O Crossmember; Non-Towing.	0

Fuel Tanks & Equip

O	Fuel Tank: 90 US Gallon 24.5 in. Aluminum Under	-4
---	--	-----------

<i>Std/ Opt</i>	<i>Description</i>	<i>Weight</i>
	replace. Class 8 fuel tanks w/o locking caps include an anti-siphon device on the filler neck.	
S	Small Round DEF Tank, 14 Gallons. The DEF tank will be located on the side you specified. If you have specific configuration or body builder concerns, please utilize the Custom Frame Layout option. Standard capacity is calculated by fuel capacity of the vehicle and will accommodate two diesel fill-ups for every DEF fill-up. For 1:1 DEF fuel fill ratio, add 7889204.	0
O	6 in. Wide Lower Fuel Tank Step, for One 22 in. or 24.5 in. tank LH.	2
S	DEF to Fuel Fill Ratio 2:1 or Greater.	0
S	Anti-Siphon Device in Fuel Tank Filler Neck. For any number of fuel tanks.	0
S	DEF Tank Location is LH.	0
O	Location: 90 gal fuel tank LH under cab.	0
Cab & Equipment		
S	Cab: Stamped Aluminum Cab with Panoramic Curved glass windshield. Standard with stamped aluminum doors, heavy duty in-swinging hinges, and triple sealed doors. Manufactured using self-piercing rivets and structural adhesive. Includes LED exterior marker lights and turn signals.	0
O	Hood: T880 Set-Back Medium Length. 122.6 inch BBC W/Std Bumper.	15
O	Fine Particulate Filter for Cabin Air HVAC system. To provide extra filtration in high dust applications. Cabin airflow is reduced with this additional filter. *Cannot be used with code 8108003.	0
S	Cab HVAC - Day Cab and 40 in. Sleeper System With Defrost, A/C, and 48,000 BTU/hr Heater. Includes automatic temperature control with one touch defrost operation and dash mounted cab temperature and solar intensity sensors. Pleated fresh air filter and cabin recirculation air filter standard. The Kenworth HVAC system is designed to provide optimal heating and cooling in all operating environments without need for additional insulation. Cab HVAC without sleeper heater AC is available with 40in sleeper.	0
S	Kenworth Smartwheel: 18 in. Non-Leather With Integrated Radio and Cruise Controls.	0
O	Column Mtd Retarder Control, RH Side Use with Manual & Allison Transmissions Only.	0
S	Adjustable Telescoping Tilt Steering Column.	0
O	5 Sets of Keys. Replaces Standard 2 Sets of Keys.	0
O	Customer Specified Tumbler P/N. All Chassis keyed alike if applicable. Includes ignition, cab doors & if applicable, sleeper tool box door. 2.1m models. G key will not work on new P lock	0

Std/ Opt	Description	Weight
	and ignition.	
	<i>Narr P0444</i>	
O	Information for Customer-Installed PTO Muncie 10-bolt.	0
O	Dash Switch:1st Allison-Mounted PTO. Electric switch and wiring are factory-installed to control the 1st Allison Trans mounted PTO.	0
O	Two Spare Switches: Wired to Power.	0
O	Dash Switch: W/Light & Guard for Truck Dump Gate. Includes approximately 3 meters of coiled wire BOC in LH rail.	0
O	Gauge: Engine Oil Temperature Gauge With Integral warning light. The NavPlus HD unit includes a virtual engine oil temperature gauge.	0
S	Gauge: DD Virtual Gauge - Oil Temp Engine	0
S	Gauge: DD Virtual Gauge - Manifold Pressure Boost	0
S	Gauge: DD Virtual Gauge - Engine Percent Torque	0
O	Gauge: Fuel Filter Restriction Gauge.	0
O	Gauge: Manifold Pressure Gauge. The NavPlus HD unit includes a virtual manifold pressure gauge.	0
O	Gauge: Axle Oil Temperature, Dual-Drive Axle. (2 gauges) w/integral warning light.	0
O	Gauge: Oil Temperature Gauge Transmission. The NavPlus HD unit includes a virtual transmission oil temperature gauge.	0
S	Main Instrument Package: 15" Digital Display. Includes Speedometer, Tachometer, Primary Air Pressure, Secondary Air Pressure, Fuel Level #1, DEF Level, DPF Filter Status, Fuel Economy, Oil Pressure, Coolant Temp, OAT and Voltmeter, and Air Application.	0
O	Modular Dash Options: RH Dash Storage Unit With two shelves. Reduces total gauge count; HD by 6 and MD by 4.	0
S	Interior Color: Slate Gray	0
S	Interior Package: Vantage Daycab Includes durable headliner and vinyl sidewalls with geometric patterned trim and anodized aluminum accents throughout. Convenient overhead storage cubbies, full size glove box, two center console cupholders, and large door pad map pocket. Standard LH/RH power windows, electric door locks, interior LED lighting, nighttime-friendly red ambient lighting for dash and footwell, and door mounted courtesy light. Includes two standard 12V power outlets. Driver sunvisor includes strap.	0
S	Rubber Floormat	0

<i>Std/ Opt</i>	<i>Description</i>	<i>Weight</i>
O	Driver Seat: GT701 HB with Vinyl material. The GT701 is standard with a single air bag, scissor linkage seat suspension. It includes a single chamber lumbar support, 10in Fore/Aft adjustment, 7in Up/Down adjustment, 2.5in pan extension, 51 degree seat back recline, and 16 degree full seat tilt. Includes 3-point matching seat belts. DR seat standard w/ dual armrests.	0
O	Rider Seat: GT100 Toolbox IB with Vinyl Material. The GT100 seats are standard with fixed base. Includes 3-point matching seat belts. Rider seat standard w/ LH armrest.	0
S	Seat Color: Black	0
O	Driver and Rider Seat Belts: Orange Seat Belts. Replacing standard color.	0
O	Kenworth Radio DEA710 AM/FM/WB/USB, Bluetooth	0
S	Base Level Audio System - Daycab:High Performance Door Speakers.	0
S	Turn Signal: Non-Self Cancelling	0
S	LH and RH Trip Ledge Rain Deflectors	0
S	Global Telematics Unit	0
O	Grabhandle: LH SOC Non-Slip Ergonomic Grab Handle Mounted To The Left Hand Exterior Of The Cab For Entry and Exit. NFPA Compliant.	3
S	Dual Cab Interior Grabhandles: A Pillar Mounted Dash Wrap and B Pillar Mounted Grabhandles	0
S	Kenworth Daylite Door With Standard LH/RH electric door locks and LH/RH electric window controls.	0
S	Single Air Horn Under Cab.	0
S	Look-Down, Pass. Door, Black 11x6	0
S	Aero Mirror: Dual Kenworth Aerodynamic Motorized heated mirrors, 7in X 13in with cab color mirror shell and black mirror arms. Also includes LH/RH heated 6in X 7in convex mirrors. Mirror brackets set for 8-1/2 ft load width. Mirror controls located on driver side door pad.	0
S	Rear Cab Stationary Window 19in x 36in	0
S	One-Piece Bonded-In Windshield With Curved Glass. Standard.	0
S	Wheelwell Fender Extension: 2.5 Inches	0
S	Kenworth Cab/Sleeper Air Suspension.	0
Lights & Instruments		
S	Headlamps: SAE Dual Halogen Complex Reflector	0

<i>Std/ Opt</i>	<i>Description</i>	<i>Weight</i>
S	Marker Lights: Five Rectangular LED.	0
S	Turn Signal Lights: Flush Mounted LED. Mounted at top of fender wheel arc.	0
S	LED Stop,Turn,Tail: With Two LED Backup Lights and With An LED License Plate.	0
O	Headlamps to Turn on When Wipers are Active.	0
S	Marker Lights: Interrupter Switch. Included in Turn Signal For All Models Except T3. The T3 Switch Is In The Dash.	0
O	Brake Lights on when Engine Brake Active. Can only be selected when chassis also has engine brake. Cannot be used with options to delete engine brake.	0
O	Electric Backup Alarm: Meets SAE J994 & OSHA requirements.	4
O	Junction Box: End of Frame	1
O	Polyswitches Replacing Fuses. Switch Will automatically reset after removal of excess load.	0
Air Equipment		
S	Air Dryer: Bendix AD-HF Puraguard Heated	0
S	Moisture Ejection Valve W/ Pull Cable Drain.	0
S	Nylon Air Tubing in Frame & Cab, Excluding Hoses subject to excessive heat or flexing.	0
Extended Warranty		
S	Base Warranty - Standard Service Heavy Duty 12 months / 100,000 miles / 160,000 km.	0
O	EW: US Basic Vehicle 5 year/100,000 miles, United States only.	0
O	Cummins EW: Protect Plan 1 X15 EPA24 5YR/100K (160,935KM), Efficiency/Productivity Series. Each code registered between 366 and 546 days after the vehicles in-service date will be subject to a \$400 late fee. Coverage cannot be added after 200K MI or 545 days past the in-service date	0
O	Cummins EW: Aftertreatment X15 Use W/ PP1 EPA24 5YR/100K (160,935KM), Efficiency/Productivity Series. Each code registered between 366 and 546 days after the vehicles in-service date will be subject to a \$400 late fee. Coverage cannot be added after 200K MI or 545 days past the in-service date	0
O	Allison 4000 Series Transmission Surcharge	0
O	TruckTech+ RD - 5YR Sub Cummins Engines	0

<i>Std/ Opt</i>	<i>Description</i>	<i>Weight</i>
O	Base Warranty: Emissions 5YR/100K MI - EPA Engine	0
Miscellaneous		
O	GHG Secondary Manufacturer: Does Not Apply	0
O	Warning Triangle Reflector Kit: Shipped Loose. Kit consists of 3 triangles in plastic carrying case. Not floor mounted.	4
O	One 5 lb. Dry Chemical Type Fire Extinguisher mounted outboard of driver seat. Class ABC.	11
S	EMUX Architecture	0
Promotions		
Paint		
O	Paint Color Number(s). N9702 A - L0436 SIERRA BLUE N9720 FRAME N0001 BLACK	0
O	Bumper Unpainted	0
O	Day Cab Standard Paint	0
S	1 - Color Paint - Day Cab Color will be White if no other color is specified.	0
O	Non-Standard Paint Color.	0
S	Base Coat/ Clear Coat. The Kenworth Color Selector contains additional instructions, as well as information on Kenworth paint guidelines and surface finish applications. Kenworth is standard with Dupont Imron Elite paint.	0

Special Requirements

- Special Requirement 1 0098025
- Special Requirement 2
- Special Requirement 3
- Special Requirement 4

Order Comments

Total Weight (lbs)

16,522

Any price increase as the result of force majeure, rising costs of components (including but not limited to material shortages) or government tariffs are not included in the quoted price and will be the financial responsibility of the customer.

Prices and Specifications Subject to Change Without Notice.

Unpublished options may require review/approval.

Dimensional and performance data for unpublished options may vary from that displayed in CRM.

PRICING DISCLAIMER

While we make every effort to maintain the web site to preserve pricing accuracy, prices are subject to change without notice. Although the information in this price list is presented in good faith and believed to be correct at the time of printing, we make no representations or warranties as to the completeness or accuracy of this information. We reserve the right to change, delete or otherwise modify the pricing information which is represented herein without any prior notice. We carefully check pricing specifications, but occasionally errors can occur, therefore we reserve the right to change such prices without notice. We disclaim all liability for any errors or omissions in the materials. In no event will we be responsible for any damages of any nature whatsoever from the reliance upon information from these materials. Please check your order prebills to confirm your pricing information

HORIZONTAL DIMENSIONS

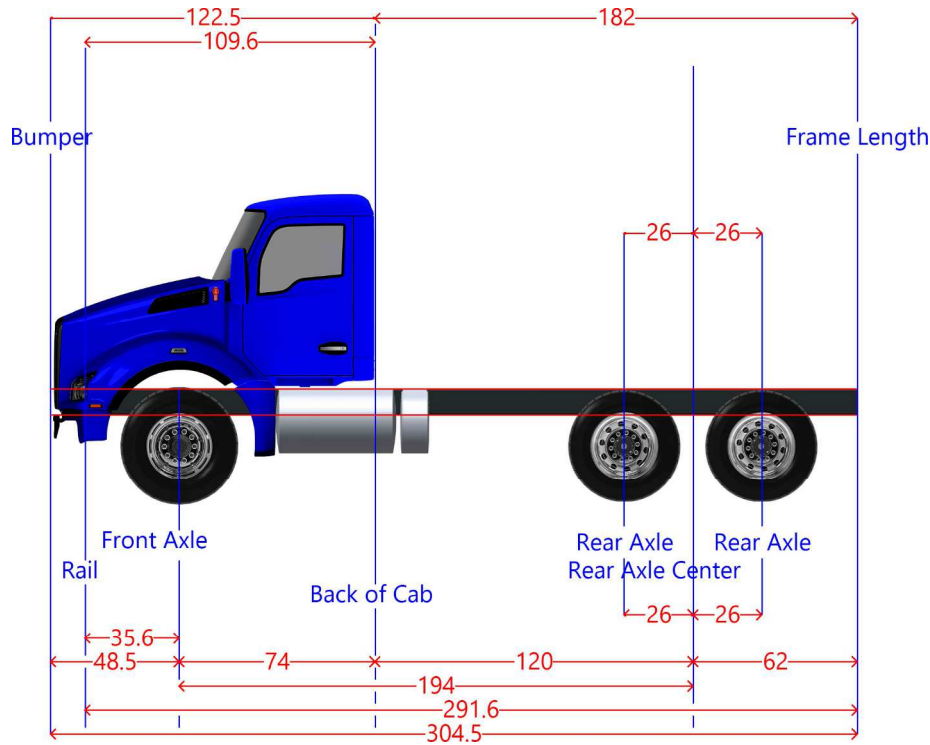

Dimension	Measurement	Start	End
Axle Spacing	52	168	220
Bumper to Back of Cab	122.5	-48.5	74
Bumper to Front Axle	48.5	-48.5	0
Bumper to Front Frame	12.9	-48.5	-35.6
Cab to End of Frame	182.0	74	256
Cab to Rear Axle	120.0	74	194
Effective Bumper to Back Of Cab	122.5	-48.5	74
Frame Length	291.6	-35.6	256
Front Axle to Back of Cab	74.0	0	74
Front of Frame to Axle	35.6	-35.6	0
Load Space	182.0	74	256
Overall Length	304.5	-48.5	256
Overhang	62.0	194	256

Pusher Offset #1	26.0	168	194
Pusher Offset #2	26.0	168	194
Pusher Offset #3	26.0	168	194
Tag Offset	26.0	194	220
Wheelbase	194	0	194

FRAME LAYOUT

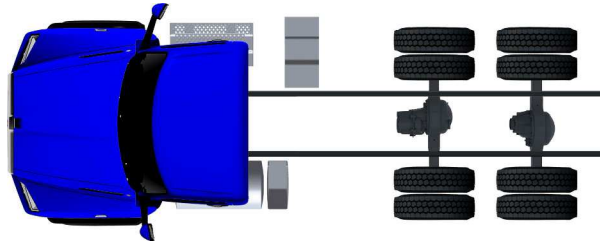

Note: Optional content may be displayed. The order has not yet received an engineering review. The actual arrangement of components may not be exactly as pictured. Additional changes may be made to the layout by Kenworth. Add a Custom Frame Layout code if an exact layout is required.

Selected Options (Wheelbase: 194)

Sales Code	Description	Length	Side
7210090	Fuel Tank: 90 US Gallon 24.5 in. Aluminum Under	45.5	Left
7722153	Small Round DEF Tank, 14 Gallons.	10.2	Left
6400636	Battery Box Cantilever Aluminum BOC with	18.2	Right

PERFORMANCE TRUCK - BROOKSHIRE

34211 Katy Freeway, Brookshire, 81 77423

Phone: (281) 239-7383

BUYER'S ORDER

Date Prepared: 09-26-2025		Delivery Date: 02-28-2026		Salesman: Drew Vest		Branch: Brookshire	
Purchaser: Fort Bend County				Telephone: 281-342-4513 Fax:			
Mailing Address: 301 Jackson City: Richmond State: TX Zip: 77469						County: Fort Bend	
Physical Address: 201 Payne Lane City: Richmond State: TX Zip: 77469						County: Fort Bend	
Description: NEW 2026 KENWORTH T380				Email Address: russell.hurta@fortbendcountytx.gov			
Mileage:		Color: L0436EY Sierra Blue		NOTE: Buy Board Contract #723-23			
VIN: TO ORDER Comments: See attached vehicle summary, quote ID # QUO-1130145-N7L4R4.							
Purchaser's Agent: Russell Hurta			Title: GM Fleet Operations			License Type: Commercial	Account # FBC

LICENSE - TITLE INFORMATION							
Months: 12	Tractor:	Truck: X	Trailer:	Body Type: DUMP	Color: BLU	Tons:	GCW: 33000
Apportioned:	IMC #	Combination:	Com'l: X	Token Trailer:	Gas:	Diesel: X	

INSURANCE INFORMATION			
AGENCY:		SELLING PRICE*	151,355.00
NAME:	PHONE:	ACCESSORIES	-
LIEN INFORMATION		CASH PRICE W/ACCESS.	151,355.00
NAME:	LIEN DATE:	TRADE IN ALLOWANCE	-
ADDRESS:	PHONE:	NET CASH DIFFERENCE	151,355.00
CITY, STATE, ZIP:		FEDERAL RETAIL EXCISE TAX	-
COMMENTS:		NET PRICE	151,355.00
AMOUNT:	NAME:	STATE SALES TAX	-
		LICENSE MO. & FEE	-
ADDITIONAL INFORMATION		TITLE FEE (INCLUDES \$5 TAG FEE)	10.00
Proposal is per truck for ASAP build. Estimated delivery date to be confirmed at time of order.		COMMERCIAL INSPECTION FEE	-
Buy Board Contract #723-23		DEALER'S INVENTORY TAX	-
New Kenworth T380 Dump Truck		DOCUMENTARY FEE**	75.00
Paccar PX7 Engine (325 HP) / Allison 3000RDS Trans		EXTENDED WARRANTY	3,240.00
Truck Fabricators - 5yd Dump Body w/ Electric Tarp & Pintle Hitch installed		SUBTOTAL	154,680.00
		BALANCE OWED ON TRADE	-
		SUBTOTAL	154,680.00
Extended warranties include coverage up to 5 years or 100k miles on Basic Vehicle, Engine and Aftertreatment.		PREPAYMENT	-
		BALANCE DUE UPON DELIVERY	154,680.00

DISCLAIMER OF WARRANTY		* PRICE IS SUBJECT TO INDUSTRY AND ENVIRONMENTAL COST IMPACTS BEYOND THE CONTROL OF PERFORMANCE TRUCK	
<p>Any warranties on the products sold hereby are those made by the manufacturer. The seller, CLEVELAND MACK SALES, INC., PERFORMANCE TRUCK OR PERFORMANCE TRAILER, hereby expressly disclaims all warranties, either express or implied, including any implied warranty of merchantability or fitness for a particular purpose, and CLEVELAND MACK SALES, INC., PERFORMANCE TRUCK OR PERFORMANCE TRAILER neither assumes nor authorizes any other person to assume for it any liability in connection with the sale of said products.</p>		** A DOCUMENTARY FEE IS NOT AN OFFICIAL FEE. A DOCUMENTARY FEE IS NOT REQUIRED BY LAW, BUT MAY BE CHARGED TO BUYERS FOR HANDLING DOCUMENTS RELATING TO THE SALE. A DOCUMENTARY FEE MAY NOT EXCEED A REASONABLE AMOUNT AGREED TO BY THE PARTIES. THIS NOTICE IS REQUIRED BY LAW.	

Vehicle(s) are subject to prior sale and will not be held more than five working days.

PURCHASER _____

THIS ORDER NOT BINDING UNTIL ACCEPTED BY DEALER.

SALESPERSON _____

ACCEPTED BY _____



PERFORMANCE TRUCK - CLEVELAND (C359)
 1287 HIGHWAY 59 NORTH
 CLEVELAND, Texas 77328

FORT BEND COUNTY
 201 PAYNE LANE
 RICHMOND, Texas 77469
 United States of America

Drew Vest
 Cell Phone: 281-610-8007
 Office Phone: 713-844-7111
 Email: avest@performancetruck.com

RUSSELL HURTA
 Email: russell.hurta@fortbendcountytexas.gov

Vehicle Summary

	Unit		Chassis	
Model:	T380 Series Conventional	Fr Axle Load (lbs):		12000
Type:	FULL TRUCK	Rr Axle Load (lbs):		21000
Description 1:	T380 DUMP TRK	G.C.W. (lbs):		33001
Description 2:	2026 Budget			
	Application	Road Conditions:		
Intended Serv.:	Construction: Vehicles used in the	Class A (Highway)		88
	cons			
Commodity:	Gravel/Crushed Rock/Sand	Class B (Hwy/Mtn)		10
		Class C (Off-Hwy)		2
		Class D (Off-Road)		0
	Body	Maximum Grade:		6
Type:	End Dump	Wheelbase (in):		158
Length (ft):	8	Overhang (in):		93
Height (ft):	12	Fr Axle to BOC (in):		69.5
Max Laden Weight (lbs):	4000			
		Cab to Axle (in):		88.5
		Cab to EOF (in):		181.5
	Trailer	Overall Comb. Length (in):		291
No. of Trailer Axles:	0			
Type:				
Length (ft):	0			
Height (ft):	0			
Kingpin Inset (in):	0			
Corner Radius (in):	0			
	Restrictions			
Length (ft):	75			
Width (in):	102			
Height (ft):	13.5			

Special Req.
 U.S. Domestic Registry, 50-state.

Approved by: _____

Date: _____

Note: All sales are F.O.B. designated plant of manufacture.

Std/ Opt	Description	Weight
Model		
S	T380 Series Conventional	9,930
S	T380 Aero Hood	0
O	CARB Low NOX Omnibus Registration Guidelines Dealer/Customer acknowledges that this vehicle is NOT intended for registration or domicile/primary use in the State of California.	0
O	EPA Clean Idle Label - PACCAR PX Engines	0
O	T380 Automatic	0
O	State of Registry: Texas	0
Engine & Equipment		
O	PACCAR PX-7 325 325@2400 750@1600, 2024 With Turbo Exhaust Brake (VGT Brake) N09420 C333 0.....Reserve Speed Limit Offset (N09380 C334 0.....Maximum Cycle Distance (C334 N09360 C400 252...Reserve Speed Function Reset N09200 C399 100...Standard Maximum Speed Limit N09400 C401 10....Maximum Active Distance (C40 N09220 C402 0.....Expiration Distance (C402) N09540 C395 0.....Expiration Distance (C395) N09260 C121 68....Max Vehicle Speed in Top Gea N09440 C234 YES...Engine Protection Shtdwn N09460 C231 NO....Gear Down Protection N09580 C133 5.....Idle Shtdwn Time N09680 C233 NO....Idle Shtdwn Override N09480 C132 1400..Max PTO Speed N09300 C128 68....Max Cruise Control Speed N09500 C239 NO....Cruise Control Auto Resume N09520 C238 NO....Auto Engine Brake in Cruise N09780 C190 80....High Ambient Temperature Thr N09740 C188 40....Low Ambient Temperature Thre N09760 C189 60....Intermediate Ambient Tempera N09720 C382 YES...Enable Hot Ambient Automatic N09600 C396 YES...Enable Impending Shutdown Wa N09620 C397 60....Timer For Impending Shutdown N09640 C206 35....Engine Load Threshold N09560 C225 NO....Enable Idle Shutdown Park Br	0
O	EPA Emissions Warranty Engine	0
S	PremierSpec	0
O	Gearing Analysis: Balance power/economy blend results.	0
O	Customer's Typical Operating Spd: 68 MPH	0

Std/ Opt	Description	Weight
O	EWI Tracking - A2 Engine Module Chassis	0
	RegistrationYear Year of Registration: 2025	0
O	Effective VSL Setting NA	0
O	Engine Idle Shutdown Timer Disabled	0
O	Eff EIST NA Expiration Miles Use only with MX and Cummins engines	0
S	Air Compressor: Cummins 18.7 CFM For Cummins And PACCAR PX engines.	0
S	Air Cleaner: MD Composite Engine Mounted	0
O	Inside/Outside Air Intake for Engine Mounted Air Cleaner	16
O	Fan Hub: Horton Variable Speed For use with PX engines, L9N or B6.7N natural gas engines on 2.1M only.	0
O	Cooling Module: 2.1M MD Aero Hood, Clog Resistant 1000 Square Inches	0
O	Bug Screen: Behind Grille	2
O	EXH: Single Can 2024 RH Under with RH Side-of-Cab Vertical Tailpipe	0
O	Tailpipe: 5 in. single 36 in. 45 degree curved.	15
S	Fuel Filter: PACCAR 2.1M MD for PX-7 or PX-9 Fuel/water separator for 2021 and later engines.	0
S	Run Aid:None *For Fuel Filter	0
S	Start Aid:None *For Fuel Filter	0
O	Alternator: 160 amp Brush Type T3	0
O	Batteries: 3 PACCAR GP31 Threaded Post (700-730) 2100-2190 CCA dual purpose.	62
S	Starter: PACCAR 90P47 12V with PACCAR PX-7	0
O	Battery Disconnect Switch Mounted on Battery Box Provides One (1) Switch	0
O	Jump Start Terminals Under Hood.	0
S	Remote PTO/Throttle, 12-Pin, 250K, Back of Cab OR Back of Sleeper, J1939, Remote Control Provision	0
Transmission & Clutch		
O	Transmission: Allison 3000RDS 6-speed, With PTO	443

<i>Std/ Opt</i>	<i>Description</i>	<i>Weight</i>
	drive gear. 6th Generation controls. Includes heat exchanger & oil level sensor. Rugged Duty Series for vocational applications. Requires a push button shift control code. Oil temperature gauge is standard on class 8 models. Transynd transmission fluid is standard on all Allison 1000, 2000, 3000 & 4000 series transmissions.	
O	Driveline: 2 Dana SPL170XL 1 Centerbearing	84
O	One Heavy-Duty One-Piece Aluminum Crossmember This option upgrades an existing crossmember. The cost does not include the centerbearing and bracket. Crossmember location will be in accordance with Kenworth engineering standards, using the major components specified on the DTPO.	0
O	Torque Converter Included W/ Allison Transmission.	0
O	Push Button Shifter Controls, Center Console Mounted for Allison Transmission. 2.1m Medium Duty only.	0
O	Allison Fuel Sense: Delete	0
O	J1939 Park Brake Auto Neutral	0
O	Allison Neutral at Stop	0
O	Rear Transmission Support Springs for transmission PTO applications are required to ensure that engine flywheel housings are not overloaded when transmission PTO's are installed.	0
O	Customer Installed Transmission PTO in the LH Mounted position (8 o'clock) for Allison 3000 & 4000 transmissions.	0
Front Axle & Equipment		
O	Meritor MFS12E PLUS 12K 3.5in. drop standard track.	-1
O	Front Brakes: 14.6K Bendix Air Disc Brakes Lube Free.	0
O	Splined Rotor for Front Air Disc Brakes for Use with Aluminum Hubs.	0
O	Integral Knuckle for Air Disc Brake, for use on Meritor MFS PLUS Steer Axle	20
O	Front Hub: 14,600 lbs. Aluminum Hub Pilot 10-bolt, 11.25 in. bolt circle.	-48
S	ConMet PreSet Plus Hub Package; Front Axle.	0
S	Hubcap: Front Vented.	0
O	Slack Adjusters Included W/ Front Axle or Brakes. Also use with disc brakes.	0
O	Front Springs: Taperleaf 12K w/ shock absorbers. With maintenance-free elastomer spring pin bushings.	58
S	Single Power Steering Gear: 13.2K for Air Brakes.	0

<i>Std/ Opt</i>	<i>Description</i>	<i>Weight</i>
O	30 mm Front Suspension Spacer Block	0
O	Threaded Front Spring Bushings in Place of elastomeric.	0
Rear Axle & Equipment		
O	Single Meritor RS23-160 Rear Axle 21K	295
O	Rear Axle Ratio - 5.63.	0
S	Single Rear Brakes 16-1/2x7 in. Bendix ES- extended service S-cam.	0
S	Single Rear Brake Drums: Cast S-Cam Single For use with 15x8.625", 16.5X7" or 16.5X8.625" brake.	0
O	Single Rear Hubs: Aluminum Hub Pilot 23K; 11.25" bolt circle. Requires "R" series outer ends.	-26
S	ConMet PreSet Plus Hub Package; Single Rear Axle.	0
S	Single Rear Axle Automatic Slack Adjusters. For use with drum brakes.	0
S	Spring Brake: 3030 Long Stroke Single 3 in. travel. For drum brakes. Helps keep brakes in adjustment longer.	0
S	Bendix 4S/4M Anti-Lock Brake System.	0
S	Rear suspension: single Reyco 79KB taperleaf 21K. Medium-duty. Unladen Height: 9 in. Laden Height: 7.5 in. Not rear air disc brake compatible.	0
O	Bolted Rear Suspension Crossmembers for Reyco 79KB. Replaces medium duty standard.	41
Tires & Wheels		
O	Front tires: Continental HSR3 11R22.5 16PR. Includes pressure sensor.	38
O	Rear tires: Continental HDR2+ 11R22.5 14PR	88
O	Rear Tire Quantity: 4	0
O	Front Wheel: Accuride 50882 22.5X8.25 steel heavy-duty 22.5x8.25; Steel Armor[TM] powder coat, hub-pilot mount. 8000lb. maximum rating. 2-hand holes. Air disc brake compatible.	31
O	Rear Wheel: Accuride 50882 white 22.5X8.25 heavy-duty 22.5x8.25; Steel Armor[TM] powder coat, hub-pilot mount. 8000lb. maximum rating. 2-hand holes. Air disc brake compatible. Code is priced per pair of wheels.	58
O	Powder Coat White Steel Wheel. Use in Conjunction with front, dual front, rear, spare or lift axle wheel code(s). All wheels on chassis must have same finish color.	0
O	Rear Wheel/Rim Quantity: 4	0

<i>Std/ Opt</i>	<i>Description</i>	<i>Weight</i>
Frame & Equipment		
O	Frame Rails: 10-11/16 x 3-1/2 x 1/2in. Steel to 336in. Truck frame weight is 4.70 lb.-in. per pair of rails. Section modulus is 22.35, RBM is 2,683,000 in-lbs per rail. Frame rail availability may be restricted based upon application, axle/suspension capacity, fifth wheel setting, or component/dimensional specifications. The results of the engineering review may result in a change to the requested frame rail. If a change is required Kenworth Application Engineering will advise the dealer of the appropriate material specification for a substitute rail.	619
O	Bumper: Aerodynamic Chrome Steel. Requires a bumper setting code.	68
S	40 in. Bumper Setting. Requires a Bumper Code.	0
S	Front Tow Loops: Two	0
O	Custom Frame Layout: Two Chassis CFL A/T: CLEAR OF TRANS AREA, TOWARD REAR AXLE & BENEATH RAIL CFL F/T: CLEAR BOC CFL A/D: CLEAR OF TRANS AREA	0
O	Battery Box Cantilever Aluminum BOC with Smooth natural finish aluminum cover.	19
S	Battery Box Location: RH Side.	0
O	DPF/SCR Box Natural End Plates and Natural cover.	0
O	Heavy-Duty One-PC Aluminum Intermediate/ Fill-In crossmember.	13
O	Heavy-Duty 5-Piece Rear Cab Support, Hucked assembly. Huck fastened to frame.	15
O	Final End-of-Frame Cut-Off Dimension Will be modified to 61 in. to 65 in.	0
O	Rear Mudflap Arms: Betts B-25 Standard-Duty, straight. Includes B1732 mounting brackets as standard.	12
O	Rear Mudflap Shields: White Plastic Antisail W/ Kenworth logo.	9
O	Quarter Fenders: Stainless Steel W/ Painted Steel brackets, single post mounted.	55
S	Square End-of-Frame W/O Crossmember; Non-Towing.	0
Fuel Tanks & Equip		
S	50 US Gallon D-Shape Rectangular Aluminum Under fuel tank, replace. With non-slip step.	0
S	Small DEF Tank, 5.5 Gallons.	0
O	DEF to Fuel Fill Ratio 2:1 or Greater.	0

<i>Std/ Opt</i>	<i>Description</i>	<i>Weight</i>
O	Anti-Siphon Device in Fuel Tank Filler Neck. For any number of fuel tanks.	1
S	DEF Tank Location is LH Under Cab.	0
S	Location: 50 gal fuel tank LH under cab.	0
Cab & Equipment		
S	Cab: Stamped Aluminum with Curved Windshield LED markers. Requires separate roof code.	0
O	Hood: Med Aero w/ Chrome Crown	0
O	Fine Particulate Filter for Cabin Air HVAC system. To provide extra filtration in high dust applications. Cabin airflow is reduced with this additional filter. *Cannot be used with code 8108003.	0
S	Cab HVAC - Day Cab and 40 in. Sleeper System With Defrost, A/C, and 48,000 BTU/hr Heater. Includes automatic temperature control with one touch defrost operation and dash mounted cab temperature and solar intensity sensors. Pleated fresh air filter and cabin recirculation air filter standard. The Kenworth HVAC system is designed to provide optimal heating and cooling in all operating environments without need for additional insulation. Cab HVAC without sleeper heater AC is available with 40in sleeper.	0
O	Kenworth Smartwheel: 18 in. Non-Leather With Integrated Radio and Cruise Controls.	0
S	Adjustable Telescoping Tilt Steering Column.	0
O	5 Sets of Keys. Replaces Standard 2 Sets of Keys.	0
O	Customer Specified Tumbler P/N. All Chassis keyed alike if applicable. Includes ignition, cab doors & if applicable, sleeper tool box door. 2.1m models. G key will not work on new P lock and ignition.	0
<i>Narr P0444</i>		
O	Dash Mounted Compact Trailer Brake Valve. Self Returning.	0
O	Information for Customer-Installed PTO Muncie 10-bolt.	0
O	Dash Switch:1st Allison-Mounted PTO. Electric switch and wiring are factory-installed to control the 1st Allison Trans mounted PTO.	0
O	Two Spare Switches: Wired to Power.	0
O	Gauge: DD Virtual Gauge - Manifold Pressure Boost	0
O	Gauge: DD Virtual Gauge - Engine Percent Torque	0

<i>Std/ Opt</i>	<i>Description</i>	<i>Weight</i>
O	Gauge: DD Virtual Gauge - Engine Hours Instrument Cluster	0
O	Gauge: DD Virtual Gauge - Volts Instrument Cluster	0
S	Main Instrument Package: 7" Digital Display Cluster. Includes Physical (Analog): Speedometer, Tachometer, Oil Pressure, and Coolant Temp; and Digital: Fuel Level #1, DEF Level, DPF Filter Status, Fuel Economy, Volts Telltale, OAT and Primary Air Pressure, Secondary Air Pressure, and Air Application for air brake trucks.	0
O	Modular Dash Options: RH Dash Storage Unit With two shelves. Reduces total gauge count; HD by 6 and MD by 4.	0
S	Interior Trim Package: 2.1M MD Gray Foam Backing/Cloth Headliner W/Gray Sunvisor & Seat Color Three Underdash Center Console Cupholders (Two If Allison Transmission Is Selected).	0
O	Driver Seat: KW Air Seat HB Vinyl w/ Dual Armrests/Susp Cover	0
O	Rider Seat: KW Toolbox Seat IB Vinyl w/ Dual Armrests	0
O	Driver and Rider Seat Belts: Orange Seat Belts. Replacing standard color.	0
O	Kenworth Radio DEA710 AM/FM/WB/USB, Bluetooth	0
O	Speaker Package For Cab: (2) Speakers B-Pillar	0
S	Turn Signal: Self-Cancelling	0
S	LH and RH Trip Ledge Rain Deflectors	0
O	Metal Int Door Panel Kick Plates	0
S	Global Telematics Unit	0
O	Long Grabhandle RH Side Mounted to Side-of-Cab exhaust.	2
O	Grabhandle: LH, Exterior, Side of Cab - Ergonomic Grab Handle Mounted To The Left Hand Exterior Of The Cab For Entry and Exit.	3
S	Dual Cab Interior Grabhandles: A Pillar Mounted Dash Wrap and B Pillar Mounted Grabhandles	0
S	Kenworth Daylite Door With Standard LH/RH electric door locks and LH/RH electric window controls.	0
O	Single Air Horn Under Cab.	0
S	Look-Down, Pass. Door, Black 11x6	0

<i>Std/ Opt</i>	<i>Description</i>	<i>Weight</i>
O	Mirror Shell: Dual Aero Chrome	0
O	Mirror: Dual KW Aero Rear View Motor, heated with Integral CX.	0
S	Rear Cab Stationary Window 19in x 36in	0
O	3.5in x 11.5in Plastic Records Holder:Mounted On Rear Cab Panel. Not available With Sleeper Or 2 Person Bench Seat.	0
S	One-Piece Bonded-In Windshield With Curved Glass. Standard.	0
O	Kenworth Cab Air Suspension.	0
O	Thermal/Sound Insulation Package	0
O	Roof: Raised Profile, Stamped Aluminum w/ Additional Head Room & Interior Overhead Storage	0
Lights & Instruments		
S	Headlamps: Single Halogen Complex Reflector w/ Turn Indicator, Reflector and DRL. Fender Mtd.	0
O	Marker Lights: Five Rectangular LED. Chrome housing. For use with raised roof only. Required with exterior sunvisor.	0
O	Combination Stop, Tail, Turn & Backup Lights RH & LH.	0
O	Backup Alarm: Tail Light Bracket Mounted Variable self-adjusting 82-102 DBA.	0
O	Body Builder Lighting Harness Coiled End Of Frame For Additional Customer Installed Exterior Lighting. Harness Includes Circuits for Additional Customer Installed Tail Lamps, Turn Lamps, Stop Lamps, and Marker Lamps.	0
O	Polyswitches Replacing Fuses. Switch Will automatically reset after removal of excess load.	0
Air Equipment		
S	Air Dryer: Bendix AD-HF Puraguard Heated	0
S	Moisture Ejection Valve W/ Pull Cable Drain.	0
O	Full Truck Kit Gladhands mounted at end-of-frame. Seven-way female receptacle mounted at end-of-frame in taillamp bracket. Kit includes dash mounted trailer air supply valve, trailer hand control valve, and hoses/fittings for the valves. Dash mounted parking brake valve, tractor protection valve, and spring brake inversion/relay valves are standard.	15
S	Nylon Air Tubing in Frame & Cab, Excluding Hoses subject to excessive heat or flexing.	0
O	Additional 7-Way ISO 3731 Connector for Trailer ABS power One additional, w/ o light line, for full truck & tractor.	6

Extended Warranty

Price Level: August 1, 2025

100% Complete

Date: September 25, 2025

Deal: T380 DUMP TRK

Quote Number: QUO-1130145-N7L4R4

Printed On: 9/26/2025 4:30:07 AM

Std/ Opt	Description	Weight
S	Base Warranty - PACCAR PX-7 Engine 36 months / Unlimited miles & km / Unlimited hours.	0
S	Base Warranty - Standard Service Medium Duty 12 months / Unlimited miles & km	0
O	EW: US Basic Vehicle 5 year/100,000 miles, United States only.	0
O	PACCAR EW: PX-7 Protect Plan 1 EPA24 5YR/100K (160,935KM). Each code registered between 366 and 546 days after the vehicles in-service date will be subject to a \$400 late fee. Coverage cannot be added after 200K MI or 545 days past the in-service date	0
O	PACCAR EW: Aftertreatment PX-7 Use W/ PP1 EPA24 5YR/100K (160,935KM). Each code registered between 366 and 546 days after the vehicles in-service date will be subject to a \$400 late fee. Coverage cannot be added after 200K MI or 545 days past the in-service date	0
O	Allison 3000 Series Transmission Surcharge	0
O	TruckTech+ RD - 5YR Sub PACCAR PX Engines	0
O	Base Warranty: Emissions 5YR/100K MI - EPA Engine	0
Miscellaneous		
O	GHG Secondary Manufacturer: Does Not Apply	0
O	Warning Triangle Reflector Kit: Shipped Loose. Kit consists of 3 triangles in plastic carrying case. Not floor mounted.	4
O	One 5 lb. Dry Chemical Type Fire Extinguisher mounted outboard of driver seat. Class ABC.	11
S	EMUX Architecture	0
Promotions		
Paint		
O	Paint Color Number(s). N9702 A - L0436 SIERRA BLUE N9720 FRAME N0001 BLACK	0
S	Bumper Unpainted	0
S	Day Cab Standard Paint	0
S	1 - Color Paint - Day Cab Color will be White if no other color is specified.	0
O	Non-Standard Paint Color.	0

<i>Std/ Opt</i>	<i>Description</i>	<i>Weight</i>
S	Base Coat/ Clear Coat. The Kenworth Color Selector contains additional instructions, as well as information on Kenworth paint guidelines and surface finish applications. Kenworth is standard with Dupont Imron Elite paint.	0

Special Requirements

- Special Requirement 1 0098025
- Special Requirement 2
- Special Requirement 3
- Special Requirement 4

Order Comments

Total Weight (lbs)

11,958

Any price increase as the result of force majeure, rising costs of components (including but not limited to material shortages) or government tariffs are not included in the quoted price and will be the financial responsibility of the customer.

Prices and Specifications Subject to Change Without Notice.

Unpublished options may require review/approval.

Dimensional and performance data for unpublished options may vary from that displayed in CRM.

PRICING DISCLAIMER

While we make every effort to maintain the web site to preserve pricing accuracy, prices are subject to change without notice. Although the information in this price list is presented in good faith and believed to be correct at the time of printing, we make no representations or warranties as to the completeness or accuracy of this information. We reserve the right to change, delete or otherwise modify the pricing information which is represented herein without any prior notice. We carefully check pricing specifications, but occasionally errors can occur, therefore we reserve the right to change such prices without notice. We disclaim all liability for any errors or omissions in the materials. In no event will we be responsible for any damages of any nature whatsoever from the reliance upon information from these materials. Please check your order prebills to confirm your pricing information

HORIZONTAL DIMENSIONS

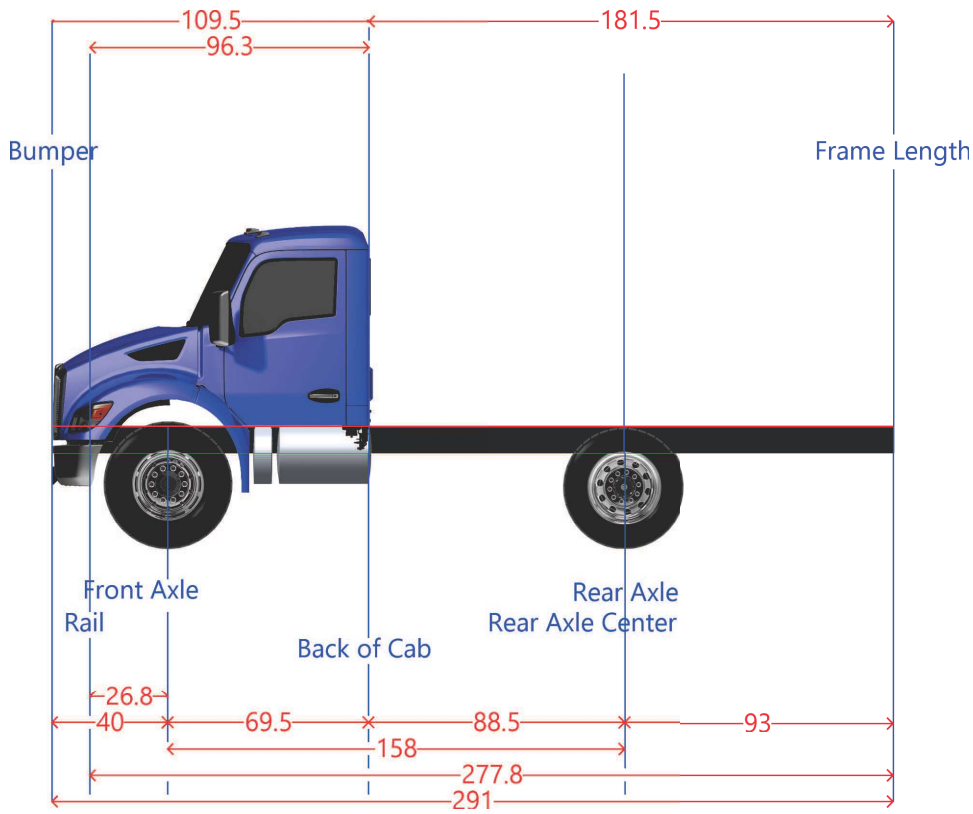

Dimension	Measurement	Start	End
Axle Spacing	0	158	158
Bumper to Back of Cab	109.5	-40	69.5
Bumper to Front Axle	40.0	-40	0
Bumper to Front Frame	13.2	-40	-26.8
Cab to End of Frame	181.5	69.5	251
Cab to Rear Axle	88.5	69.5	158
Effective Bumper to Back Of Cab	109.5	-40	69.5
Frame Length	277.8	-26.8	251
Front Axle to Back of Cab	69.5	0	69.5
Front of Frame to Axle	26.8	-26.8	0
Load Space	181.5	69.5	251
Overall Length	291.0	-40	251
Overhang	93.0	158	251
Pusher Offset #1	0.0	158	158
Pusher Offset #2	0.0	158	158
Pusher Offset #3	0.0	158	158
Tag Offset	0.0	158	158
Wheelbase	158	0	158

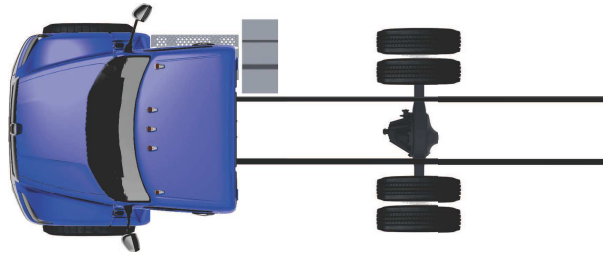

Note: Optional content may be displayed. The order has not yet received an engineering review. The actual arrangement of components may not be exactly as pictured. Additional changes may be made to the layout by Kenworth. Add a Custom Frame Layout code if an exact layout is required.

Selected Options (Wheelbase: 158)

Sales Code	Description	Length	Side
7140050	50 US Gallon D-Shape Rectangular Aluminum Under	32.7	Left
7722170	Small DEF Tank, 5.5 Gallons.	6.6	Left
6400644	Battery Box Cantilever Aluminum BOC with Smooth	18.2	Right

PERFORMANCE TRUCK - BROOKSHIRE

34211 Katy Freeway, Brookshire, 81 77423

Phone: (281) 239-7383

BUYER'S ORDER

Date Prepared: 09-26-2025		Delivery Date: 02-28-2026		Salesman: Drew Vest		Branch: Brookshire	
Purchaser: Fort Bend County				Telephone: 281-342-4513 Fax:			
Mailing Address: 301 Jackson City: Richmond State: TX Zip: 77469						County: Fort Bend	
Physical Address: 201 Payne Lane City: Richmond State: TX Zip: 77469						County: Fort Bend	
Description: NEW 2026 KENWORTH T880				Email Address: russell.hurta@fortbendcountytx.gov			
Mileage:		Color: L0436EY Sierra Blue		NOTE: Buy Board Contract #723-23			
VIN: TO ORDER Comments: See attached vehicle summary, quote ID # QUO-1130148-S1V9H6.							
Purchaser's Agent: Russell Hurta			Title: GM Fleet Operations			License Type: Commercial Account # FBC	

LICENSE - TITLE INFORMATION

Months: 12	Tractor: X	Truck:	Trailer:	Body Type: N/A	Color: BLU	Tons:	GCW: 80000
Apportioned:	IMC #	Combination:	Com'l: X	Token Trailer:	Gas:	Diesel: X	

INSURANCE INFORMATION

AGENCY:	
NAME:	PHONE:

LIEN INFORMATION

NAME:	LIEN DATE:
ADDRESS:	PHONE:
CITY, STATE, ZIP:	
COMMENTS:	
AMOUNT:	NAME:

SELLING PRICE*	248,260.00
ACCESSORIES	-
CASH PRICE W/ACCESS.	248,260.00
TRADE IN ALLOWANCE	-
NET CASH DIFFERENCE	248,260.00
FEDERAL RETAIL EXCISE TAX	-
NET PRICE	248,260.00
STATE SALES TAX	-
LICENSE MO. & FEE (APR)	-
TITLE FEE (INCLUDES \$5 TAG FEE)	10.00
COMMERCIAL INSPECTION FEE	-
DEALER'S INVENTORY TAX	-
DOCUMENTARY FEE**	75.00
EXTENDED WARRANTY	5,655.00
SUBTOTAL	254,000.00
BALANCE OWED ON TRADE	-
SUBTOTAL	254,000.00
PREPAYMENT	-
BALANCE DUE UPON DELIVERY	254,000.00

ADDITIONAL INFORMATION

Proposal is per truck for ASAP build. Estimated lead time to be confirmed at time of order.	
Buy Board Contract #723-23	
New Kenworth T880 Haul Truck	
Cummins X15 Engine (450 HP) / Allison 4500RDS Trans	
50k Winch, Light Bar, Steel Fenders, Tail Board & Toolbox installed	
Extended warranties include coverage up to 5 years or 100k miles on Basic Vehicle, Engine and Aftertreatment.	

DISCLAIMER OF WARRANTY

Any warranties on the products sold hereby are those made by the manufacturer. The seller, CLEVELAND MACK SALES, INC., PERFORMANCE TRUCK OR PERFORMANCE TRAILER, hereby expressly disclaims all warranties, either express or implied, including any implied warranty of merchantability or fitness for a particular purpose, and CLEVELAND MACK SALES, INC., PERFORMANCE TRUCK OR PERFORMANCE TRAILER neither assumes nor authorizes any other person to assume for it any liability in connection with the sale of said products.

* PRICE IS SUBJECT TO INDUSTRY AND ENVIRONMENTAL COST IMPACTS BEYOND THE CONTROL OF PERFORMANCE TRUCK

** A DOCUMENTARY FEE IS NOT AN OFFICIAL FEE. A DOCUMENTARY FEE IS NOT REQUIRED BY LAW, BUT MAY BE CHARGED TO BUYERS FOR HANDLING DOCUMENTS RELATING TO THE SALE. A DOCUMENTARY FEE MAY NOT EXCEED A REASONABLE AMOUNT AGREED TO BY THE PARTIES. THIS NOTICE IS REQUIRED BY LAW.

Vehicle(s) are subject to prior sale and will not be held more than five working days.

PURCHASER _____

THIS ORDER NOT BINDING UNTIL ACCEPTED BY DEALER.

SALESPERSON _____

ACCEPTED BY _____



PERFORMANCE TRUCK - CLEVELAND (C359)
 1287 HIGHWAY 59 NORTH
 CLEVELAND, Texas 77328

FORT BEND COUNTY
 201 PAYNE LANE
 RICHMOND, Texas 77469
 United States of America

Drew Vest
 Cell Phone: 281-610-8007
 Office Phone: 713-844-7111
 Email: avest@performancetruck.com

RUSSELL HURTA
 Email:
 russell.hurta@fortbendcountytexas.gov

Vehicle Summary

	Unit		Chassis	
Model:	T880 Series Conventional	Fr Axle Load (lbs):		13200
Type:	TRACTOR	Rr Axle Load (lbs):		40000
Description 1:	T880 HAUL TRK	G.C.W. (lbs):		80000
Description 2:	2026 Budget			
	Application	Road Conditions:		
Intended Serv.:	Linehaul: Vehicles (trucks or tractors)	Class A (Highway)		90
Commodity:	General Freight	Class B (Hwy/Mtn)		10
		Class C (Off-Hwy)		0
		Class D (Off-Road)		0
	Body	Maximum Grade:		6
Type:		Wheelbase (in):		188
Length (ft):	0	Overhang (in):		60
Height (ft):	0	Fr Axle to BOC (in):		74
Max Laden Weight (lbs):	0			
		Cab to Axle (in):		114
	Trailer	Cab to EOF (in):		174
No. of Trailer Axles:	2	Overall Comb. Length (in):		860.5
Type:	Flatbed.			
Length (ft):	53			
Height (ft):	12	Special Req.		
Kingpin Inset (in):	12	U.S. Domestic Registry, 50-state.		
Corner Radius (in):	2			
	Restrictions			
Length (ft):	75			
Width (in):	102			
Height (ft):	13.5			

Approved by: _____

Date: _____

Note: All sales are F.O.B. designated plant of manufacture.

Std/ Opt	Description	Weight
Model		
S	T880 Series Conventional	15,549
S	T880	0
O	CARB Low NOX Omnibus Registration Guidelines Dealer/Customer acknowledges that this vehicle is NOT intended for registration or domicile/primary use in the State of California.	0
O	EPA Clean Idle Label - Cummins Engines	0
S	Non-Sleeper w/ Rear Axle Capacity less than 59K.	0
O	State of Registry: Texas	0
Engine & Equipment		
O	Cummins X15 450V 450@1900 1650@900, 2024 with Intebrake, Productivity Series N09420 C333 0.....Reserve Speed Limit Offset (N09380 C334 0.....Maximum Cycle Distance (C334 N09360 C400 252...Reserve Speed Function Reset N09200 C399 100...Standard Maximum Speed Limit N09400 C401 10....Maximum Active Distance (C40 N09220 C402 0.....Expiration Distance (C402) N09540 C395 0.....Expiration Distance (C395) N09260 C121 68....Maximum Accelerator Pedal Ve N09440 C234 YES...Engine Protection Shutdown (N09460 C231 NO....Gear Down Protection (C231) N09580 C133 5.....Timer Setting (C133) N09680 C233 NO....Idle Shutdown Manual Overrul N09480 C132 1400..Max PTO Speed (C132) N09300 C128 68....Maximum Cruise Speed (C128) N09500 C239 NO....Cruise Control Auto Resume (N09520 C238 NO....Auto Engine Brake in Cruise N09240 C209 100...Hard Maximum Speed Limit (C2 N09780 C190 80....High Ambient Temperature Thr N09740 C188 40....Low Ambient Temperature Thre N09760 C189 60....Intermediate Ambient Tempera N09720 C382 YES...Enable Hot Ambient Automatic N09600 C396 YES...Enable Impending Shutdown Wa N09620 C397 60....Timer For Impending Shutdown N09640 C206 35....Engine Load Threshold (C206) N09560 C225 YES...Enable Idle Shutdown Park Br	470
O	EPA Emissions Warranty Engine	0
S	PremierSpec	0
O	Gearing Analysis: Balance power/economy blend results.	0

Std/ Opt	Description	Weight
O	Customer's Typical Operating Spd: 68 MPH	0
O	EWI Tracking - A2 Engine Module Chassis	0
	RegistrationYear Year of Registration: 2025	0
O	Effective VSL Setting 65.0 MPH or Greater (USA)	0
O	Engine Idle Shutdown Timer Disabled	0
O	Eff EIST NA Expiration Miles Use only with MX and Cummins engines	0
O	Air Compressor: Cummins 18.7 CFM, Naturally Aspirated for Cummins X15 and X15N engines	0
S	Air Cleaner: Composite Firewall Mounted PACCAR or Cummins Engines	0
O	Pre-Cleaner Mounted in the Hood Plenum	0
O	Fan Hub: Horton 2-Speed for X15/X15N	0
S	Cooling module: 1330 square inches. Includes aluminum radiator core, aluminum charge air cooler, translucent surge tank and washer bottle, silicone hoses, and extended life coolant.	0
O	Bug Screen: Between Hood & Grille	2
S	EXH: Single Can 2024 RH Under with RH Side-of-Cab Vertical Tailpipe	0
O	Tailpipe: 5 in. single 24 in. 45 degree curved.	-3
O	Fuel Filter:PACCAR Extended Service Interval Fuel/Water Separator, 2017 and Later Emissions	0
S	Run Aid:Fuel Heat *For Fuel Filter	0
S	Start Aid:12V Heat *For Fuel Filter	0
O	Alternator: PACCAR 160 amp, Brush Type	0
S	Batteries: 3 PACCAR GP31 Threaded Post (700-730) 2100-2190 CCA dual purpose.	0
O	PACCAR Premium 12V Starter W/ Cummins X15 Engines PACCAR 12 volt electrical system. With centralized power distribution incorporating plug-in style relays. Circuit protection for serviceability, 12- volt light system with circuit protection circuits number & color coded.	0
S	12V Low Voltage Disconnect for Battery Protection	0
O	Jump Start Terminals Under Hood.	12
O	Remote PTO/Throttle, 12-Pin, 250K End of Frame,	0

Std/ Opt	Description	Weight
	J1939, Remote Control Provision	
Transmission & Clutch		
O	Transmission: Allison 4500RDS 6-speed, With PTO drive gear. No Retarder. 6th Generation controls. For vocational applications. Includes shift control, transmission oil temperature gauge, oil level sensor & heat exchanger. Transynd transmission fluid is standard on all Allison 1000, 2000, 3000 & 4000 series transmissions.	478
O	Driveline: 2 Meritor RPL25 SD; 1 Centerbearing	104
O	Torque Converter Included W/ Allison Transmission.	0
O	Pushbutton Control Center Console Mounted. Class 8 with Allison Transmission.	0
O	Allison Fuel Sense: Delete	0
O	J1939 Park Brake Auto Neutral	0
O	Allison Neutral at Stop	0
O	Customer Installed Transmission PTO in the LH Mounted position (8 o'clock) for Allison 3000 & 4000 transmissions.	0
Front Axle & Equipment		
O	Dana Spicer D-13211L Front Axle rated 13.2K 3.5" drop. Use With Air Disc Brakes Only	-224
O	Front Brakes: 14.6K Bendix RSD ADB22X Disc Brake.	0
S	Splined Rotor for Front Air Disc Brakes for Use with Aluminum Hubs.	0
O	Front Hub: Aluminum Hub Pilot 13,200 lbs. 10-Bolt, 11-1/4 in. bolt circle .	0
S	ConMet PreSet Plus Hub Package; Front Axle.	0
S	Hubcap: Front Vented.	0
S	Slack Adjusters Included W/ Front Axle or Brakes. Also use with disc brakes.	0
O	Front Springs: Taperleaf 13.2K W/ Shock Absorbers w/ maintenance-free elastomer spring pin bushings. Standard with rubber pins. Not available on W900L.	-117
O	Single Power Steering Gear: 13.2K TRW THP60	-62
S	Power Steering Cooler:Radiator Mounted Air-to-Oil	0
O	Threaded Bushings for Taperleaf Springs 12K - 14.6K replacing rubber: T6/T8, W900B, W990. W9L gets as standard: code not required. Not available with W9S. 13K - 14.6K for T370.	0

<i>Std/ Opt</i>	<i>Description</i>	<i>Weight</i>
Rear Axle & Equipment		
O	Dual Meritor MP40-14x3 Rear Axle rated at 40K. Tandem rear axles with pump.	-441
O	Rear Axle Ratio - 3.90.	0
O	Dual Rear Brakes Bendix RSD-Compliant ADB22X Disc brake for tandem axle, Max GAWR 46k.	0
S	Splined Rotor for Dual Rear Air Disc Brake for use with aluminum hubs.	0
S	Dual Rear Hubs: Aluminum Hub Pilot 46K; 11.25" bolt circle. Requires "R" series outer ends.	0
S	ConMet PreSet Plus Hub Package; Dual Rear Axle.	0
S	Rear Slack Adjusters Included W/ Axle or Air disc brakes.	0
S	Spring Brakes Included W/ Dual Rear Air Disc brakes.	0
O	FMVSS-136 Stability Control Schedule Review Chassis meets FMVSS-136 requirements and must be equipped with Electronic Stability Control. Reference Option code placed on order.	0
O	Bendix 4S/4M Anti-Lock Brake System W/ Air traction control (ATC) & electronic stability program (ESP) for tractor.	11
S	Interaxle Driveline: 1 Meritor RPL20 Replacing I/A *Use W/ RPL(SD) 25 Main D/L	0
O	Driver Controlled Differential Lock (Crosslock) for Meritor Axles 40K to 52K forward rear & rear rear axle. Under Speed Interlock is standard on T680.	39
O	Rear suspension: Tandem Kenworth Airglide 400 40K 54 in. axle spacing. Air suspension w/ 9 in. ride height. Includes air suspension dump valve.	-134
O	Delete Standard Heavy-Duty Air Springs for Rear suspension.	-28
O	Air Suspension Over-Inflation Valve W/ Warning light to temporarily raise the frame.	0
Tires & Wheels		
O	Front tires: Continental HSR3 11R22.5 16PR. Includes pressure sensor.	-114
O	Rear tires: Continental HDR2+ 11R22.5 14PR	176
O	Rear Tire Quantity: 8	0
O	Front Wheel: Kenworth 7-spoke 88U68 22.5x8.25 aluminum with Ultra One high polish finish, hub-pilot mount. 7300lb. maximum rating. Level 1 finish. Air disc brake compatible.	-40
O	Rear Wheel: Kenworth 7-spoke 88u68 22.5x8.25 aluminum with Ultra One, high polish finish, hub-pilot mount. 7300 lb. maximum rating. Air disc brake compatible. Code is priced per pair of wheels. Level 1 finish.	-160

<i>Std/ Opt</i>	<i>Description</i>	<i>Weight</i>
O	Rear Wheel/Rim Quantity: 8	0
Frame & Equipment		
S	Frame Rails: 10-3/4 x 3-1/2 x 3/8in. Steel to 284 in. Truck frame weight is 3.48 lb.-in. per pair of rails. Section modulus is 17.80, RBM is 2,132,000 in-lbs per rail. Frame rail availability may be restricted based upon application, axle/suspension capacity, fifth wheel setting, or component/dimensional specifications. The results of the engineering review may result in a change to the requested frame rail. If a change is required Kenworth Application Engineering will advise the dealer of the appropriate material specification for a substitute rail.	240
O	Bumper: Tapered Polished Aluminum Channel. Requires a bumper setting code.	-6
S	48.5 in. Bumper Setting. Requires a Bumper Code.	0
O	Front Tow Hook: Center Mounted, Cast. Requires iron front drive brackets.	28
O	Steel Shackle Links.	8
O	Brackets: Iron Front Spring Drive. Included with front spring capacity of 16,000 lbs or greater; code not required.	47
O	Custom Frame Layout: One Chassis CFL DEF: AS FAR FORWARD AS POSSIBLE CFL F/T: FUEL TANKS AS FAR FORWARD AS POSSIBLE CFL A/T: CLEAR OF TRANSMISSION AREA	0
O	Huck Bolts Throughout Frame, where Possible.	0
O	Battery Box Cantilever Aluminum BOC with fiberglass cover.	8
O	Battery Box Location: RH Side.	15
O	Frame Access Grabhandle(s) LH Mounted. Placement and quantity of grabhandles may vary due to FMCSR frame access requirements.	2
O	Frame Access Grabhandle Horizontal Mounted at midpoint of sleeper or Daycab.	2
O	Deckplate: standard coverage, 4 feet maximum unless less fits for space constraints.	18
S	C5, T6, T8 diamond plate cover and black end plates with access step for right hand under DPF/SCR or CNG. For T8, use extended length non-polished battery box on opposite rail to match the length of under cab components. End plates will be painted standard black frame color.	0
O	Fifth Wheel: ILS>40K air Hol FW35M912XL00 12 in. slide, 9 in. height. Outboard mounting angles, 55K vertical rating, LH release. Air slide control valve standard in dash. Accommodates a 2 in. SAE kingpin. Requires some style of trailer connections.	521
O	Fifth Wheel Ramps. Requires Standard or Short tractor taper bent and weld.	22

Std/ Opt	Description	Weight
O	Any Changes to Rear Cab/Sleeper Area Must Comply w/FMCSR 399.	0
O	Customer-Installed Bulkhead and/or Headache rack.	0
	FifthWheelSetting FW rear/fixed setting ahd of bogie 0 in indicates rearmost setting measured forward from centerline of tandem or single rear axle	0
S	Rear Mudflap Arms: Betts B-25 Standard-Duty, straight. Includes B1732 mounting brackets as standard.	0
S	Rear Mudflap Shields: White Plastic Antisail W/ Kenworth logo.	0
O	Top Flange of Rear Frame Bent & Welded W/ crossmember. Non-towing end-of-frame configuration.	17

Fuel Tanks & Equip

O	Fuel Tank: 150 US Gallon 24.5 in. Aluminum Under replace. Class 8 fuel tanks w/o locking caps include an anti-siphon device on the filler neck. A third tank support is required with this tank unless heavy-duty 7 in. wide supports are specified.	63
O	Medium Round DEF Tank, 23.8 Gallons. The DEF tank will be located on the side you specified. If you have specific configuration or body builder concerns, please utilize the Custom Frame Layout option. Standard capacity is calculated by fuel capacity of the vehicle and will accommodate two diesel fill-ups for every DEF fill-up. For 1:1 DEF fuel fill ratio, add 7889204.	15
O	Extended Steps on Fuel Tank LH Under for Access; 2 steps, 1 tank.	2
O	Minimum Required DEF to Fuel Fill Ratio 1:1.	0
O	DEF capacity ratio - Truck to be centrally fueled	0
S	Anti-Siphon Device in Fuel Tank Filler Neck. For any number of fuel tanks.	0
S	DEF Tank Location is LH.	0
O	Location: 150 gal fuel tank LH under cab.	0

Cab & Equipment

S	Cab: Stamped Aluminum Cab with Panoramic Curved glass windshield. Standard with stamped aluminum doors, heavy duty in-swinging hinges, and triple sealed doors. Manufactured using self- piercing rivets and structural adhesive. Includes LED exterior marker lights and turn signals.	0
O	Hood: T880 Set-Back Medium Length. 122.6 inch BBC W/Std Bumper.	15
O	Fine Particulate Filter for Cabin Air HVAC system. To provide extra filtration in high dust applications. Cabin airflow is reduced with this additional filter. *Cannot be used with code 8108003.	0

<i>Std/ Opt</i>	<i>Description</i>	<i>Weight</i>
S	Cab HVAC - Day Cab and 40 in. Sleeper System With Defrost, A/C, and 48,000 BTU/hr Heater. Includes automatic temperature control with one touch defrost operation and dash mounted cab temperature and solar intensity sensors. Pleated fresh air filter and cabin recirculation air filter standard. The Kenworth HVAC system is designed to provide optimal heating and cooling in all operating environments without need for additional insulation. Cab HVAC without sleeper heater AC is available with 40in sleeper.	0
S	Kenworth Smartwheel: 18 in. Non-Leather With Integrated Radio and Cruise Controls.	0
O	Column Mtd Retarder Control, RH Side Use with Manual & Allison Transmissions Only.	0
S	Adjustable Telescoping Tilt Steering Column.	0
O	5 Sets of Keys. Replaces Standard 2 Sets of Keys.	0
O	Customer Specified Tumbler P/N. All Chassis keyed alike if applicable. Includes ignition, cab doors & if applicable, sleeper tool box door. 2.1m models. G key will not work on new P lock and ignition.	0
	<i>Narr P0444</i>	
O	Dash Mounted Compact Trailer Brake Valve. Self Returning.	0
O	Auto Suspension Dump W/PTO Engagement Interlock. This feature automatically dumps air from the truck suspension when any PTO is engaged. The intent of this feature is to deflate the air suspension air bags while the load is raised to help alleviate any imbalance or instability that can occur with the air bags inflated.	2
O	Information for Customer-Installed PTO Muncie 10-bolt.	0
O	Dash Switch:1st Allison-Mounted PTO. Electric switch and wiring are factory-installed to control the 1st Allison Trans mounted PTO.	0
O	Two Spare Switches: Wired to Power.	0
O	Gauge: Air Suspension Pressure Gauge.	0
S	Gauge: DD Virtual Gauge - Oil Temp Engine	0
S	Gauge: DD Virtual Gauge - Manifold Pressure Boost	0
S	Gauge: DD Virtual Gauge - Engine Percent Torque	0
O	Gauge: Fuel Filter Restriction Gauge.	0
O	Gauge: Manifold Pressure Gauge. The NavPlus HD unit includes a virtual manifold pressure gauge.	0

<i>Std/ Opt</i>	<i>Description</i>	<i>Weight</i>
O	Gauge: Axle Oil Temperature, Dual-Drive Axle. (2 gauges) w/integral warning light.	0
O	Gauge: Oil Temperature Gauge Transmission. The NavPlus HD unit includes a virtual transmission oil temperature gauge.	0
S	Main Instrument Package: 15" Digital Display. Includes Speedometer, Tachometer, Primary Air Pressure, Secondary Air Pressure, Fuel Level #1, DEF Level, DPF Filter Status, Fuel Economy, Oil Pressure, Coolant Temp, OAT and Voltmeter, and Air Application.	0
O	Modular Dash Options: RH Dash Storage Unit With two shelves. Reduces total gauge count; HD by 6 and MD by 4.	0
S	Interior Color: Slate Gray	0
S	Interior Package: Vantage Daycab Includes durable headliner and vinyl sidewalls with geometric patterned trim and anodized aluminum accents throughout. Convenient overhead storage cubbies, full size glove box, two center console cupholders, and large door pad map pocket. Standard LH/RH power windows, electric door locks, interior LED lighting, nighttime-friendly red ambient lighting for dash and footwell, and door mounted courtesy light. Includes two standard 12V power outlets. Driver sunvisor includes strap.	0
S	Rubber Floormat	0
O	Driver Seat: GT701 HB with Vinyl material. The GT701 is standard with a single air bag, scissor linkage seat suspension. It includes a single chamber lumbar support, 10in Fore/Aft adjustment, 7in Up/Down adjustment, 2.5in pan extension, 51 degree seat back recline, and 16 degree full seat tilt. Includes 3-point matching seat belts. DR seat standard w/ dual armrests.	0
O	Rider Seat: GT100 Toolbox IB with Vinyl Material. The GT100 seats are standard with fixed base. Includes 3-point matching seat belts. Rider seat standard w/ LH armrest.	0
S	Seat Color: Black	0
O	Driver and Rider Seat Belts: Orange Seat Belts. Replacing standard color.	0
O	Kenworth Radio DEA710 AM/FM/WB/USB, Bluetooth	0
S	Base Level Audio System - Daycab:High Performance Door Speakers.	0
S	Turn Signal: Non-Self Cancelling	0
S	LH and RH Trip Ledge Rain Deflectors	0
S	Global Telematics Unit	0
O	Long Grabhandle RH Side Mounted to Side-of-Cab exhaust.	2
O	Grabhandle: LH, Exterior, Side of Cab - Ergonomic	3

<i>Std/ Opt</i>	<i>Description</i>	<i>Weight</i>
	Grab Handle Mounted To The Left Hand Exterior Of The Cab For Entry and Exit.	
S	Dual Cab Interior Grabhandles: A Pillar Mounted Dash Wrap and B Pillar Mounted Grabhandles	0
S	Kenworth Daylite Door With Standard LH/RH electric door locks and LH/RH electric window controls.	0
O	Dual Rectangular Air Horn 23 in. LH & RH Top of roof. Includes air horn covers.	4
S	Look-Down, Pass. Door, Black 11x6	0
S	Aero Mirror: Dual Kenworth Aerodynamic Motorized heated mirrors, 7in X 13in with cab color mirror shell and black mirror arms. Also includes LH/RH heated 6in X 7in convex mirrors. Mirror brackets set for 8-1/2 ft load width. Mirror controls located on driver side door pad.	0
O	Rear Cab Stationary Window with Dark Tint 19in x 36in.	0
S	One-Piece Bonded-In Windshield With Curved Glass. Standard.	0
S	Exterior Stainless Steel Sunvisor.	19
S	Wheelwell Fender Extension: 2.5 Inches	0
S	Kenworth Cab/Sleeper Air Suspension.	0
O	Extreme Temperature Insulation: Daycab Additional cab side wall insulation with improved material properties over standard insulation package.	0
Lights & Instruments		
S	Headlamps: SAE Dual Halogen Complex Reflector	0
S	Marker Lights: Five Rectangular LED.	0
S	Turn Signal Lights: Flush Mounted LED. Mounted at top of fender wheel arc.	0
S	LED Stop, Turn, Tail: With Two LED Backup Lights and With An LED License Plate.	0
O	Floodlights: Dual LED Pedestal First Set	0
O	Floodlight Location: Located High - First Set. This Code To Be Used With Flush-Mount (9052011) or C/I (9058071) Codes Only.	0
S	Marker Lights: Interrupter Switch. Included in Turn Signal For All Models Except T3. The T3 Switch Is In The Dash.	0
O	Brake Lights on when Engine Brake Active. Can only be selected when chassis also has engine brake. Cannot be used with options to delete engine brake.	0
O	Electric Backup Alarm: Meets SAE J994 & OSHA	4

<i>Std/ Opt</i>	<i>Description</i>	<i>Weight</i>
	requirements.	
O	Junction Box: End of Frame	1
O	Polyswitches Replacing Fuses. Switch Will automatically reset after removal of excess load.	0
Air Equipment		
O	Air Dryer: Bendix AD-HF Extended Purge Heated With Puraguard	0
S	Moisture Ejection Valve W/ Pull Cable Drain.	0
O	Tractor Kit: Center Frame-Mounted W/ Hosetenna. Includes composite gladhand/light plug holder. Kit includes dash mounted trailer air supply valve, trailer hand control valve, and hoses/fittings for the valves. Dash mounted parking brake valve and tractor protection valve are standard. Air lines are detachable at one end only, light lines are detachable at both ends. Conspicuity components are standard.	24
O	Air & light line length: 12 feet, Straight lines	0
O	Phillips 12 ft Straight Light Line W/ Metal Plugs & 12 in. lead. Must code for tractor kit.	0
S	Nylon Air Tubing in Frame & Cab, Excluding Hoses subject to excessive heat or flexing.	0
O	Locate Air Dryer Under LH Rail BOC This code requires the use of a custom frame layout code.	0
O	Trailer ABS Electric Supply Through SAE J560 7-pin connector per TMC RP137).	0
O	Optional Hosetenna Bracket Location 3ft BOC/sleeper. Hosetenna bracket will be located plus or minus six inches from any non-standard location requested	0
Extended Warranty		
S	Base Warranty - Standard Service Heavy Duty 12 months / 100,000 miles / 160,000 km.	0
O	EW: US Basic Vehicle 5 year/100,000 miles, United States only.	0
O	Cummins EW: Protect Plan 1 X15 EPA24 5YR/100K (160,935KM), Efficiency/Productivity Series. Each code registered between 366 and 546 days after the vehicles in-service date will be subject to a \$400 late fee. Coverage cannot be added after 200K MI or 545 days past the in-service date	0
O	Cummins EW: Aftertreatment X15 Use W/ PP1 EPA24 5YR/100K (160,935KM), Efficiency/Productivity Series. Each code registered between 366 and 546 days after the vehicles in-service date will be subject to a \$400 late fee. Coverage cannot be added after 200K MI or 545 days past the in-service date	0
O	Allison 4000 Series Transmission Surcharge	0

<i>Std/ Opt</i>	<i>Description</i>	<i>Weight</i>
O	TruckTech+ RD - 5YR Sub Cummins Engines	0
O	Base Warranty: Emissions 5YR/100K MI - EPA Engine	0
Miscellaneous		
O	GHG Secondary Manufacturer: Does Not Apply	0
O	Warning Triangle Reflector Kit: Shipped Loose. Kit consists of 3 triangles in plastic carrying case. Not floor mounted.	4
O	One 5 lb. Dry Chemical Type Fire Extinguisher mounted outboard of rider seat. Class ABC.	11
S	EMUX Architecture	0
Promotions		
Paint		
O	Paint Color Number(s). N9702 A - L0436 SIERRA BLUE N9720 FRAME N0001 BLACK	0
O	Bumper Unpainted	0
O	Day Cab Standard Paint	0
S	1 - Color Paint - Day Cab Color will be White if no other color is specified.	0
O	Non-Standard Paint Color.	0
S	Base Coat/ Clear Coat. The Kenworth Color Selector contains additional instructions, as well as information on Kenworth paint guidelines and surface finish applications. Kenworth is standard with Dupont Imron Elite paint.	0

Special Requirements

- Special Requirement 1 0098025
- Special Requirement 2
- Special Requirement 3
- Special Requirement 4

Order Comments

Total Weight (lbs)

16,609

Any price increase as the result of force majeure, rising costs of components (including but not limited to material shortages) or government tariffs are not included in the quoted price and will be the financial responsibility of the customer.

Prices and Specifications Subject to Change Without Notice.

Unpublished options may require review/approval.

Dimensional and performance data for unpublished options may vary from that displayed in CRM.

PRICING DISCLAIMER

While we make every effort to maintain the web site to preserve pricing accuracy, prices are subject to change without notice. Although the information in this price list is presented in good faith and believed to be correct at the time of printing, we make no representations or warranties as to the completeness or accuracy of this information. We reserve the right to change, delete or otherwise modify the pricing information which is represented herein without any prior notice. We carefully check pricing specifications, but occasionally errors can occur, therefore we reserve the right to change such prices without notice. We disclaim all liability for any errors or omissions in the materials. In no event will we be responsible for any damages of any nature whatsoever from the reliance upon information from these materials. Please check your order prebills to confirm your pricing information

HORIZONTAL DIMENSIONS

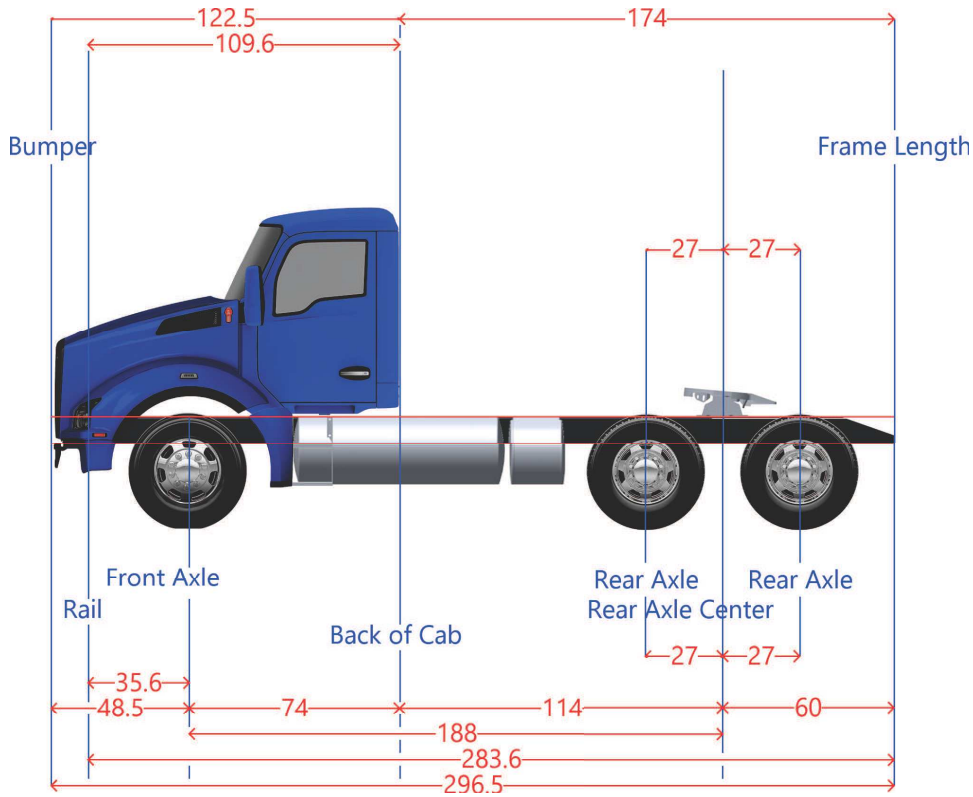

Dimension	Measurement	Start	End
Axle Spacing	54	161	215
Bumper to Back of Cab	122.5	-48.5	74
Bumper to Front Axle	48.5	-48.5	0
Bumper to Front Frame	12.9	-48.5	-35.6
Cab to End of Frame	174.0	74	248
Cab to Rear Axle	114.0	74	188
Effective Bumper to Back Of Cab	122.5	-48.5	74
Frame Length	283.6	-35.6	248
Front Axle to Back of Cab	74.0	0	74
Front of Frame to Axle	35.6	-35.6	0
Load Space	174.0	74	248
Overall Length	296.5	-48.5	248
Overhang	60.0	188	248
Pusher Offset #1	27.0	161	188
Pusher Offset #2	27.0	161	188
Pusher Offset #3	27.0	161	188
Tag Offset	27.0	188	215
Wheelbase	188	0	188

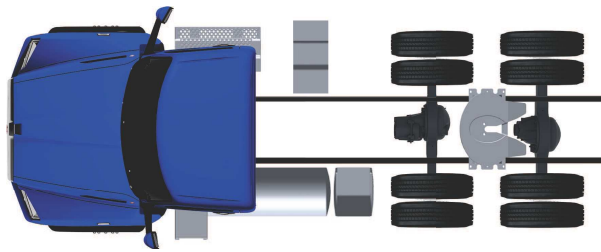

Note: Optional content may be displayed. The order has not yet received an engineering review. The actual arrangement of components may not be exactly as pictured. Additional changes may be made to the layout by Kenworth. Add a Custom Frame Layout code if an exact layout is required.

Selected Options (Wheelbase: 188)

Sales Code	Description	Length	Side
7210150	Fuel Tank: 150 US Gallon 24.5 in. Aluminum Under	74.5	Left
7839400	Extended Steps on Fuel Tank LH Under for Access;	38.5	Left
7722154	Medium Round DEF Tank, 23.8 Gallons.	16.1	Left
6400636	Battery Box Cantilever Aluminum BOC with	18.2	Right

PERFORMANCE TRUCK - BROOKSHIRE

34211 Katy Freeway, Brookshire, 81 77423

Phone: (281) 239-7383

BUYER'S ORDER

Date Prepared: 09-26-2025		Delivery Date: 05-25-2026		Salesman: Drew Vest		Branch: Brookshire	
Purchaser: Fort Bend County				Telephone: 281-342-4513 Fax:			
Mailing Address: 301 Jackson City: Richmond State: TX Zip: 77469						County: Fort Bend	
Physical Address: 201 Payne Lane City: Richmond State: TX Zip: 77469						County: Fort Bend	
Description: NEW 2026 KENWORTH T480				Email Address: russell.hurta@fortbendcountytx.gov			
Mileage:		Color: L0436EY Sierra Blue		NOTE: Buy Board Contract #723-23			
VIN: TO ORDER Comments: See attached vehicle summary, quote ID # QUO-1130146-D5K0N4.							
Purchaser's Agent: Russell Hurta			Title: GM Fleet Operations			License Type: Commercial	Account # FBC

LICENSE - TITLE INFORMATION

Months: 12	Tractor:	Truck: X	Trailer:	Body Type: OTHER	Color: BLU	Tons:	GCW: 64000
Apportioned:	IMC #	Combination:	Com'l: X	Token Trailer:	Gas:	Diesel: X	

INSURANCE INFORMATION

AGENCY:	
NAME:	PHONE:

LIEN INFORMATION

NAME:	LIEN DATE:
ADDRESS:	PHONE:
CITY, STATE, ZIP:	
COMMENTS:	
AMOUNT:	NAME:

ADDITIONAL INFORMATION

Proposal is per truck for ASAP build. Estimated delivery date is to be confirmed at time of order.	
Buy Board Contract #723-23	
New Kenworth T480 Grapple Truck	
Paccar PX9 Engine (360 HP) / Allison 4000RDS Trans	
Heil - Palfinger M13A80 body installed	
Extended Warranties include coverage up to 5 years or 100k miles on Basic Vehicle, Engine and Aftertreatment.	

SELLING PRICE*	340,980.00
ACCESSORIES	-
CASH PRICE W/ACCESS.	340,980.00
TRADE IN ALLOWANCE	-
NET CASH DIFFERENCE	340,980.00
FEDERAL RETAIL EXCISE TAX	-
NET PRICE	340,980.00
STATE SALES TAX	-
LICENSE MO. & FEE	-
TITLE FEE (INCLUDES \$5 TAG FEE)	10.00
COMMERCIAL INSPECTION FEE	-
DEALER'S INVENTORY TAX	-
DOCUMENTARY FEE**	75.00
EXTENDED WARRANTY	4,105.00
SUBTOTAL	345,170.00
BALANCE OWED ON TRADE	-
SUBTOTAL	345,170.00
PREPAYMENT	-
BALANCE DUE UPON DELIVERY	345,170.00

DISCLAIMER OF WARRANTY

Any warranties on the products sold hereby are those made by the manufacturer. The seller, CLEVELAND MACK SALES, INC., PERFORMANCE TRUCK OR PERFORMANCE TRAILER, hereby expressly disclaims all warranties, either express or implied, including any implied warranty of merchantability or fitness for a particular purpose, and CLEVELAND MACK SALES, INC., PERFORMANCE TRUCK OR PERFORMANCE TRAILER neither assumes nor authorizes any other person to assume for it any liability in connection with the sale of said products.

* PRICE IS SUBJECT TO INDUSTRY AND ENVIRONMENTAL COST IMPACTS BEYOND THE CONTROL OF PERFORMANCE TRUCK

** A DOCUMENTARY FEE IS NOT AN OFFICIAL FEE. A DOCUMENTARY FEE IS NOT REQUIRED BY LAW, BUT MAY BE CHARGED TO BUYERS FOR HANDLING DOCUMENTS RELATING TO THE SALE. A DOCUMENTARY FEE MAY NOT EXCEED A REASONABLE AMOUNT AGREED TO BY THE PARTIES. THIS NOTICE IS REQUIRED BY LAW.

Vehicle(s) are subject to prior sale and will not be held more than five working days.

PURCHASER _____

THIS ORDER NOT BINDING UNTIL ACCEPTED BY DEALER.

SALESPERSON _____

ACCEPTED BY _____



PERFORMANCE TRUCK - CLEVELAND (C359)
 1287 HIGHWAY 59 NORTH
 CLEVELAND, Texas 77328

FORT BEND COUNTY
 201 PAYNE LANE
 RICHMOND, Texas 77469
 United States of America

Drew Vest
 Cell Phone: 281-610-8007
 Office Phone: 713-844-7111
 Email: avest@performancetruck.com

RUSSELL HURTA
 Email:
 russell.hurta@fortbendcountytexas.gov

Vehicle Summary

	Unit		Chassis	
Model:	T480 Series Conventional	Fr Axle Load (lbs):		20000
Type:	FULL TRUCK	Rr Axle Load (lbs):		44000
Description 1:	T480 GRAPPLE TRK	G.C.W. (lbs):		64000
Description 2:	2026 Budget			
	Application	Road Conditions:		
Intended Serv.:	Local Pickup & Delivery: Vehicles	Class A (Highway)		93
	which			
Commodity:	Gravel/Crushed Rock/Sand	Class B (Hwy/Mtn)		5
		Class C (Off-Hwy)		2
		Class D (Off-Road)		0
	Body	Maximum Grade:		6
Type:	Crane/Boom	Wheelbase (in):		266
Length (ft):	24	Overhang (in):		118
Height (ft):	13	Fr Axle to BOC (in):		69.5
Max Laden Weight (lbs):	4000			
		Cab to Axle (in):		196.5
		Cab to EOF (in):		314.5
	Trailer	Overall Comb. Length (in):		424
No. of Trailer Axles:	0			
Type:				
Length (ft):	0			
Height (ft):	0			
Kingpin Inset (in):	0			
Corner Radius (in):	0			
	Restrictions			
Length (ft):	75			
Width (in):	102			
Height (ft):	13.5			

Special Req.
 U.S. Domestic Registry, 50-state.

Approved by: _____

Date: _____

Note: All sales are F.O.B. designated plant of manufacture.

Std/ Opt	Description	Weight
Model		
S	T480 Series Conventional	10,386
O	T480 Aero Hood	0
O	CARB Low NOX Omnibus Registration Guidelines Dealer/Customer acknowledges that this vehicle is NOT intended for registration or domicile/primary use in the State of California.	0
O	EPA Clean Idle Label - PACCAR PX Engines	0
O	T480 Tandem	0
O	State of Registry: Texas	0
Engine & Equipment		
O	PACCAR PX-9 360 360@1650 1150@1200, 2024 With Turbo Exhaust Brake (VGT Brake) N09420 C333 0.....Reserve Speed Limit Offset (N09380 C334 0.....Maximum Cycle Distance (C334 N09360 C400 252...Reserve Speed Function Reset N09200 C399 100...Standard Maximum Speed Limit N09400 C401 10....Maximum Active Distance (C40 N09220 C402 0.....Expiration Distance (C402) N09540 C395 0.....Expiration Distance (C395) N09260 C121 68....Max Vehicle Speed in Top Gea N09440 C234 YES...Engine Protection Shtdwn N09460 C231 NO....Gear Down Protection N09580 C133 5.....Idle Shtdwn Time N09680 C233 NO....Idle Shtdwn Override N09480 C132 1400..Max PTO Speed N09300 C128 68....Max Cruise Control Speed N09500 C239 NO....Cruise Control Auto Resume N09520 C238 NO....Auto Engine Brake in Cruise N09780 C190 80....High Ambient Temperature Thr N09740 C188 40....Low Ambient Temperature Thre N09760 C189 60....Intermediate Ambient Tempera N09720 C382 YES...Enable Hot Ambient Automatic N09600 C396 YES...Enable Impending Shutdown Wa N09620 C397 60....Timer For Impending Shutdown N09640 C206 35....Engine Load Threshold N09560 C225 NO....Enable Idle Shutdown Park Br	0
O	EPA Emissions Warranty Engine	0
S	PremierSpec	0
O	Gearing Analysis: Balance power/economy blend results.	0
O	Customer's Typical Operating Spd: 65 MPH	0

<i>Std/ Opt</i>	<i>Description</i>	<i>Weight</i>
O	EWI Tracking - A2 Engine Module Chassis	0
	RegistrationYear Year of Registration: 2025	0
O	Effective VSL Setting NA	0
O	Engine Idle Shutdown Timer Disabled	0
O	Eff EIST NA Expiration Miles Use only with MX and Cummins engines	0
S	Air Compressor: Cummins 18.7 CFM For Cummins And PACCAR PX engines.	0
S	Air Cleaner: MD Composite Engine Mounted	0
O	Fan Hub: Horton Variable Speed For use with PX engines, L9N or B6.7N natural gas engines on 2.1M only.	0
S	Cooling Module: 2.1M MD - Aero Hood 1000 Square Inches	0
O	Bug Screen: Behind Grille	2
O	EXH: Single Can 2024 PX-9 Horizontal Under Rail With Horizontal Tailpipe Below RH Rail Back-of-Cab	0
S	Fuel Filter: PACCAR 2.1M MD for PX-7 or PX-9 Fuel/water separator for 2021 and later engines.	0
S	Run Aid:None *For Fuel Filter	0
S	Start Aid:None *For Fuel Filter	0
O	Retarder: Jacobs for PX-9 and ISL With 3-way switch. Replaces the standard turbo brake for PX-9 engines.	57
S	Alternator: PACCAR 160 amp, Brush Type	0
S	Batteries: 2 PACCAR GP31 Threaded Post (700-730) 1400-1460 CCA dual purpose.	0
S	Mitsubishi 105P55 12V Starter with Cummins and PX PACCAR 12 volt electrical system. W/ centralized power distribution incorporating plug-in style relays. Circuit protection for serviceability, 12-volt light system w/circuit protection circuits number & color coded. Only for Cummins or PX engines.	0
O	Battery Disconnect Switch Mounted on Battery Box Provides One (1) Switch	0
O	Jump Start Terminals Under Hood.	0
O	Remote PTO/Throttle, 12-Pin, 500K, Back of Cab OR Back of Sleeper, J1939, Remote Control Provision	0

Transmission & Clutch

<i>Std/ Opt</i>	<i>Description</i>	<i>Weight</i>
O	Transmission: Allison 4000RDS 5-speed, With PTO drive gear. No Retarder. 6th Generation controls. For vocational applications. Includes shift control, transmission oil temperature gauge, oil level sensor & heat exchanger. Transynd transmission fluid is standard on all Allison 1000, 2000, 3000 & 4000 series transmissions.	799
O	Driveline: 3 Dana SPL170XL 2 Centerbearing	100
O	Two Heavy-Duty One-Piece Aluminum Crossmembers This option upgrades existing crossmembers. The cost does not include the centerbearing and bracket. Crossmember locations will be in accordance with Kenworth engineering standards, using the major components specified on the DTPO.	0
O	Torque Converter Included W/ Allison Transmission.	0
O	Push Button Shifter Controls, Center Console Mounted for Allison Transmission. 2.1m Medium Duty only.	0
O	J1939 Park Brake Auto Neutral	0
O	Allison Neutral at Stop	0
O	Allison Fuel Sense: Dynactive Includes Dynamic Shift Sensing	0
O	Rear Transmission Support Springs for transmission PTO applications are required to ensure that engine flywheel housings are not overloaded when transmission PTO's are installed.	0
O	Customer Installed Transmission PTO in the LH Mounted position (8 o'clock) for Allison 3000 & 4000 transmissions.	0
O	Supplemental Allison Oil to Water Trans Cooler	16

Front Axle & Equipment

O	Meritor MFS20 Front Axle rated 20K 3.5 in. drop, standard track.	139
O	Front Brakes: 14,601-22K Bendix Air Disc Brakes.	10
O	Splined Rotor for Front Air Disc Brakes for Use with Iron Hubs.	0
O	Front Hubs Iron Hub Pilot 20,000 lbs. 10 Bolt 16.5x6in. or 7in. or air disc brakes. 10 Bolt, 11-1/4 in. bolt circle. Consider Wheelguards (5850002) with aluminum wheels.	80
S	ConMet PreSet Plus Hub Package; Front Axle.	0
S	Hubcap: Front Vented.	0
O	Slack Adjusters Included W/ Front Axle or Brakes. Also use with disc brakes.	0
O	Front Springs: Taperleaf 20K W/ Shock Absorbers w/ maintenance-free elastomer spring pin bushings.	99
O	Dual Power Steering Gears: 18/20K	75

Std/ Opt	Description	Weight
O	Power Steering Cooler:Radiator Mounted Air-to-Oil	11
O	50 mm Front Suspension Spacer Block	0
Rear Axle & Equipment		
O	Dual Dana Spicer DSH44P Rear Axle rated at 44K w/ 12.5mm housing and 1.88in. shaft diameter. Includes pump. Tandem rear axles.	2,085
O	Rear Axle Ratio - 4.63.	0
O	Dual Rear Brakes 16-1/2x7 in. to 46K; Bendix ES-extended service S-cam.	0
O	Dual Rear Brake Drums: Cast. For use with 16.5X7" or 16.5X8.625" brake.	0
O	Dual Rear Hubs: Aluminum Hub Pilot 46K; 11.25" bolt circle. Requires "R" series outer ends.	0
O	ConMet PreSet Plus Hub Package; Dual Rear Axle.	0
O	Tandem Rear Axle Automatic Slack Adjusters. For use with drum brakes.	0
O	Spring Brake: 3030 Long Stroke Dual 30 Square inches travel. For drum brakes. Helps keep brakes in adjustment longer.	4
S	Bendix 4S/4M Anti-Lock Brake System.	0
O	Interaxle Driveline: 1 Dana SPL170XL Tandem Rear Axles Only	96
O	Wheel Differential Lock for Dana Spicer Axles DSP40/DSP41(P)/DSH40(P)/DSH44(P)/D40-155 forward rear axle & rear rear. Under Speed Interlock is standard on T680.	37
O	Rear suspension: Tandem Hendrickson Primaax EX462 46K. Steel crossmember & gussets. 54 in. axle spacing. 10 in. ride height.	511
O	Bolted Rear Suspension Crossmember for PRIMAAAX EX single. Replaces medium duty standard.	16
Tires & Wheels		
O	Front tires: Continental HAU 3 WT 315/80R22.5 20PR	98
O	Rear tires: Continental HDR2+ 11R22.5 14PR	176
O	Rear Tire Quantity: 8	0
O	Front Wheel: Accuride 29039 22.5X9 steel Steel Armor[™] powder coat, hub-pilot mount. 10000lb. maximum rating. 5-hand holes.	70
O	Rear Wheel: Accuride 50885 22.5x8.25 steel Steel Armor[™] powder coat, hub-pilot mount. Heavy-duty 5 hand-hole hub pilot mount. Code is priced per pair of wheels.	96

Std/ Opt	Description	Weight
O	Powder Coat White Steel Wheel. Use in Conjunction with front, dual front, rear, spare or lift axle wheel code(s). All wheels on chassis must have same finish color.	0
O	Rear Wheel/Rim Quantity: 8	0
Frame & Equipment		
O	Frame Rails: 10-5/8 x 3-1/2 x 5/16 in. Steel to 381 in. to 428 in. Truck frame weight is 2.91 lb.-in. per pair of rails. Section modulus is 14.80 cu.in., RBM is 1,776,000 in-lbs per rail. 120,000 PSI yield. Heat treated. Frame rail availability may be restricted based upon application, axle/suspension capacity, fifth wheel setting, or component/dimensional specifications. The results of the engineering review may result in a change to the requested frame rail. If a change is required, Kenworth Application Engineering will advise the dealer of the appropriate material specification for a substitute rail.	417
O	Full Steel Insert: for 10-5/8 in. or 10-3/4 in. Steel 337 in. to 416 in. or 2nd insert for 11-5/8 in. steel frame. Adds 1,149,000 in-lb to main rail RBM. Truck insert weight is 2.05 lb.-in. per pair of rails. Full frame insert length is equal to wheelbase plus rear frame cutoff plus dimension forward of front axle by model. See databook addendum section 7.2.	842
O	Bumper: Aerodynamic Chrome Steel. Requires a bumper setting code.	68
S	40 in. Bumper Setting. Requires a Bumper Code.	0
S	Front Tow Loops: Two	0
O	Custom Frame Layout: One Chassis CFL A/D: RIGHT SIDE	0
O	Battery Box: Steel Parallel Module under W/Step, natural aluminum cover. Use with 2 or 3 batteries. Up to 2 air tanks may be mounted to bottom of box. Batteries will be oriented perpendicular to the frame rail in a single row.	9
O	Battery Box Location: RH Side.	0
S	Heavy-Duty One-PC Aluminum Intermediate/ Fill-In crossmember.	0
S	Heavy-Duty 5-Piece Rear Cab Support, Hucked assembly. Huck fastened to frame.	0
S	Rear Mudflap Arms: Betts B-25 Standard-Duty, straight. Includes B1732 mounting brackets as standard.	0
S	Rear Mudflap Shields: White Plastic Antisail W/ Kenworth logo.	0
O	Square End-of-Frame W/ Bolted Crossmember, non-towing.	41
Fuel Tanks & Equip		
O	50 US Gallon D-Shape Rectangular Aluminum Under fuel tank, replace. With non-slip step.	22
S	Small DEF Tank, 5.5 Gallons.	0

<i>Std/ Opt</i>	<i>Description</i>	<i>Weight</i>
O	Minimum Required DEF to Fuel Fill Ratio 1:1.	0
O	DEF capacity ratio - Truck to be centrally fueled	0
O	Anti-Siphon Device in Fuel Tank Filler Neck. For any number of fuel tanks.	1
O	DEF Tank Location is LH Under Cab.	0
O	Location: 50 gal fuel tank LH under cab.	0
Cab & Equipment		
S	Cab: Stamped Aluminum with Curved Windshield LED markers. Requires separate roof code.	0
O	Hood: Med Aero w/ Chrome Crown	0
O	Fine Particulate Filter for Cabin Air HVAC system. To provide extra filtration in high dust applications. Cabin airflow is reduced with this additional filter. *Cannot be used with code 8108003.	0
S	Cab HVAC - Day Cab and 40 in. Sleeper System With Defrost, A/C, and 48,000 BTU/hr Heater. Includes automatic temperature control with one touch defrost operation and dash mounted cab temperature and solar intensity sensors. Pleated fresh air filter and cabin recirculation air filter standard. The Kenworth HVAC system is designed to provide optimal heating and cooling in all operating environments without need for additional insulation. Cab HVAC without sleeper heater AC is available with 40in sleeper.	0
O	Kenworth Smartwheel: 18 in. Non-Leather With Integrated Radio and Cruise Controls.	0
S	Adjustable Telescoping Tilt Steering Column.	0
O	5 Sets of Keys. Replaces Standard 2 Sets of Keys.	0
O	Auto Suspension Dump W/PTO Engagement Interlock. This feature automatically dumps air from the truck suspension when any PTO is engaged. The intent of this feature is to deflate the air suspension air bags while the load is raised to help alleviate any imbalance or instability that can occur with the air bags inflated.	2
O	Information for Customer-Installed PTO Muncie 10-bolt.	0
O	Dash Switch:1st Allison-Mounted PTO. Electric switch and wiring are factory-installed to control the 1st Allison Trans mounted PTO.	0
O	Two Spare Switches: Wired to Power. BOC Wire termination.	0
O	Gauge: DD Virtual Gauge - Air Suspension Pressure 1	0

<i>Std/ Opt</i>	<i>Description</i>	<i>Weight</i>
O	Gauge: DD Virtual Gauge - Air Filter Restriction	0
O	Gauge: DD Virtual Gauge - Manifold Pressure Boost	0
O	Gauge: DD Virtual Gauge - Volts Instrument Cluster	0
S	Main Instrument Package: 7" Digital Display Cluster. Includes Physical (Analog): Speedometer, Tachometer, Oil Pressure, and Coolant Temp; and Digital: Fuel Level #1, DEF Level, DPF Filter Status, Fuel Economy, Volts Telltale, OAT and Primary Air Pressure, Secondary Air Pressure, and Air Application for air brake trucks.	0
O	Modular Dash Options: RH Dash Storage Unit With two shelves. Reduces total gauge count; HD by 6 and MD by 4.	0
S	Interior Trim Package: 2.1M MD Gray Foam Backing/Cloth Headliner W/Gray Sunvisor & Seat Color Three Underdash Center Console Cupholders (Two If Allison Transmission Is Selected).	0
O	Driver Seat: KW Air Seat HB Vinyl w/ Dual Armrests/Susp Cover	0
O	Rider Seat: KW Toolbox Seat IB Vinyl w/ Dual Armrests	0
O	Seat Color: Black Replacing Standard Gray	0
O	Driver and Rider Seat Belts: Orange Seat Belts. Replacing standard color.	0
O	Kenworth Radio DEA710 AM/FM/WB/USB, Bluetooth	0
O	Speaker Package For Cab: (2) Speakers B-Pillar	0
S	Turn Signal: Self-Cancelling	0
S	LH and RH Trip Ledge Rain Deflectors	0
O	Metal Int Door Panel Kick Plates	0
S	Global Telematics Unit	0
O	Grabhandle: LH, Exterior, Side of Cab - Ergonomic Grab Handle Mounted To The Left Hand Exterior Of The Cab For Entry and Exit.	3
S	Dual Cab Interior Grabhandles: A Pillar Mounted Dash Wrap and B Pillar Mounted Grabhandles	0
S	Kenworth Daylite Door With Standard LH/RH electric door locks and LH/RH electric window controls.	0
S	Single Air Horn Under Cab.	0

<i>Std/ Opt</i>	<i>Description</i>	<i>Weight</i>
S	Look-Down, Pass. Door, Black 11x6	0
O	Mirror Shell: Dual Aero Chrome	0
O	Mirror: Dual KW Aero Rear View Motor, heated with Integral CX.	0
S	Rear Cab Stationary Window 19in x 36in	0
O	3.5in x 11.5in Plastic Records Holder:Mounted On Rear Cab Panel. Not available With Sleeper Or 2 Person Bench Seat.	0
S	One-Piece Bonded-In Windshield With Curved Glass. Standard.	0
O	4 1/4" Molded Wheelwell Fender Extension.	0
O	Kenworth Cab Air Suspension.	0
O	Thermal/Sound Insulation Package	0
O	Roof: Raised Profile, Stamped Aluminum w/ Additional Head Room & Interior Overhead Storage	0
Lights & Instruments		
O	Headlamps: Single Halogen Complex Reflector w/ Turn Indicator, Reflector and w/o DRL. Fender Mtd.	0
O	Daytime Running Lights Located in Bumper. Driven by Chassis Height.	3
S	14-Pin RP170 Body Lighting Connector.	0
O	Marker Lights: Five Rectangular LED. Chrome housing. For use with raised roof only. Required with exterior sunvisor.	0
S	LED Stop, Turn, Tail: With Two LED Backup Lights and With An LED License Plate.	0
O	Brake Lights on when Engine Brake Active. Can only be selected when chassis also has engine brake. Cannot be used with options to delete engine brake.	0
O	Reflectors: Two Midframe	0
O	Backup Alarm: Tail Light Bracket Mounted Variable self-adjusting 82-102 DBA.	0
O	Body Builder Lighting Harness Coiled End Of Frame For Additional Customer Installed Exterior Lighting. Harness Includes Circuits for Additional Customer Installed Tail Lamps, Turn Lamps, Stop Lamps, and Marker Lamps.	0
Air Equipment		
S	Air Dryer: Bendix AD-HF Puraguard Heated	0
S	Moisture Ejection Valve W/ Pull Cable Drain.	0

Std/ Opt	Description	Weight
S	Nylon Air Tubing in Frame & Cab, Excluding Hoses subject to excessive heat or flexing.	0
Extended Warranty		
S	Base Warranty - PACCAR PX-9 Engine 24 months / 250,000 miles / 402,336 km / 6250 hours.	0
O	Base Warranty - Standard Service Medium Duty 12 months / Unlimited miles & km	0
O	EW: US Basic Vehicle 5 year/100,000 miles, United States only.	0
O	PACCAR EW: PX-9 Protect Plan 1 EPA24 5YR/100K (160,935KM). Each code registered between 366 and 546 days after the vehicles in-service date will be subject to a \$400 late fee. Coverage cannot be added after 200K MI or 545 days past the in-service date	0
O	PACCAR EW: Aftertreatment PX-9 Use W/ PP1 EPA24 5YR/100K (160,935KM). Each code registered between 366 and 546 days after the vehicles in-service date will be subject to a \$400 late fee. Coverage cannot be added after 200K MI or 545 days past the in-service date	0
O	Allison 4000 Series Transmission Surcharge	0
O	TruckTech+ RD - 5YR Sub PACCAR PX Engines	0
O	Base Warranty: Emissions 5YR/100K MI - EPA Engine	0
Miscellaneous		
O	GHG Secondary Manufacturer: Does Not Apply	0
O	Warning Triangle Reflector Kit: Shipped Loose. Kit consists of 3 triangles in plastic carrying case. Not floor mounted.	4
O	One 5 lb. Dry Chemical Type Fire Extinguisher mounted outboard of driver seat. Class ABC.	11
S	EMUX Architecture	0
Promotions		
Paint		
O	Paint Color Number(s). N9702 A - L0436 SIERRA BLUE N9720 FRAME N0001 BLACK	0
S	Bumper Unpainted	0
S	Day Cab Standard Paint	0

<i>Std/ Opt</i>	<i>Description</i>	<i>Weight</i>
S	1 - Color Paint - Day Cab Color will be White if no other color is specified.	0
O	Non-Standard Paint Color.	0
S	Base Coat/ Clear Coat. The Kenworth Color Selector contains additional instructions, as well as information on Kenworth paint guidelines and surface finish applications. Kenworth is standard with Dupont Imron Elite paint.	0

Special Requirements

- Special Requirement 1 0098025
- Special Requirement 2
- Special Requirement 3
- Special Requirement 4

Order Comments

Total Weight (lbs)

16,387

Any price increase as the result of force majeure, rising costs of components (including but not limited to material shortages) or government tariffs are not included in the quoted price and will be the financial responsibility of the customer.

Prices and Specifications Subject to Change Without Notice.

Unpublished options may require review/approval.

Dimensional and performance data for unpublished options may vary from that displayed in CRM.

PRICING DISCLAIMER

While we make every effort to maintain the web site to preserve pricing accuracy, prices are subject to change without notice. Although the information in this price list is presented in good faith and believed to be correct at the time of printing, we make no representations or warranties as to the completeness or accuracy of this information. We reserve the right to change, delete or otherwise modify the pricing information which is represented herein without any prior notice. We carefully check pricing specifications, but occasionally errors can occur, therefore we reserve the right to change such prices without notice. We disclaim all liability for any errors or omissions in the materials. In no event will we be responsible for any damages of any nature whatsoever from the reliance upon information from these materials. Please check your order prebills to confirm your pricing information

HORIZONTAL DIMENSIONS

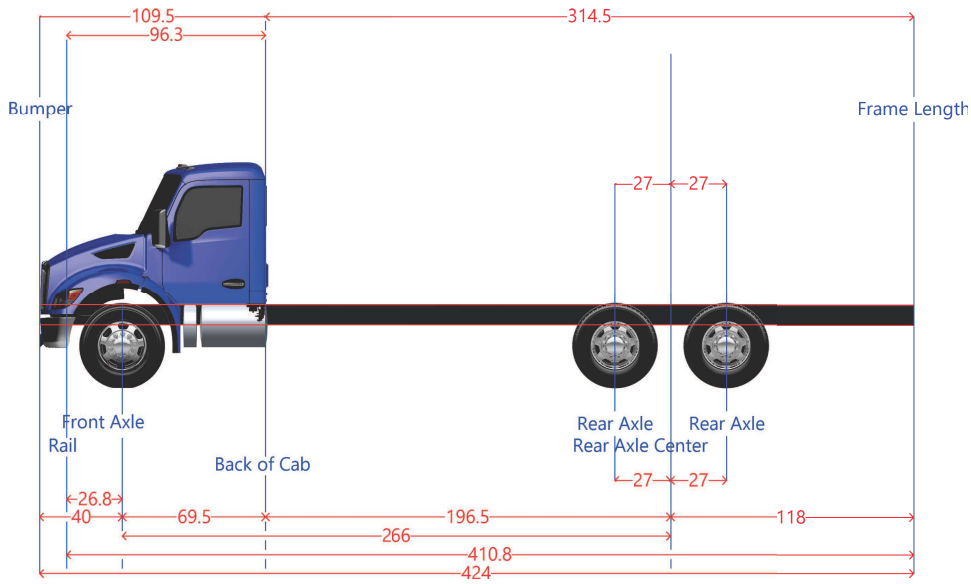

Dimension	Measurement	Start	End
Axle Spacing	54	239	293
Bumper to Back of Cab	109.5	-40	69.5
Bumper to Front Axle	40.0	-40	0
Bumper to Front Frame	13.2	-40	-26.8
Cab to End of Frame	314.5	69.5	384
Cab to Rear Axle	196.5	69.5	266
Effective Bumper to Back Of Cab	109.5	-40	69.5
Frame Length	410.8	-26.8	384
Front Axle to Back of Cab	69.5	0	69.5
Front of Frame to Axle	26.8	-26.8	0
Load Space	314.5	69.5	384
Overall Length	424.0	-40	384
Overhang	118.0	266	384
Pusher Offset #1	27.0	239	266
Pusher Offset #2	27.0	239	266
Pusher Offset #3	27.0	239	266
Tag Offset	27.0	266	293
Wheelbase	266	0	266



Note: Optional content may be displayed. The order has not yet received an engineering review. The actual arrangement of components may not be exactly as pictured. Additional changes may be made to the layout by Kenworth. Add a Custom Frame Layout code if an exact layout is required.

Selected Options (Wheelbase: 266)

Sales Code	Description	Length	Side
7140050	50 US Gallon D-Shape Rectangular Aluminum Under	32.7	Left
7722170	Small DEF Tank, 5.5 Gallons.	6.6	Left
6404420	Battery Box: Steel Parallel Module under W/Step,	31	Right

CERTIFICATE OF INTERESTED PARTIES

FORM **1295**

1 of 1

Complete Nos. 1 - 4 and 6 if there are interested parties.
Complete Nos. 1, 2, 3, 5, and 6 if there are no interested parties.

**OFFICE USE ONLY
CERTIFICATION OF FILING**

Certificate Number:
2025-1396082

Date Filed:
12/04/2025

Date Acknowledged:
12/18/2025

1 Name of business entity filing form, and the city, state and country of the business entity's place of business.
Cleveland Mack Sales, Inc. dba Performance Truck
Cleveland, TX United States

2 Name of governmental entity or state agency that is a party to the contract for which the form is being filed.
Fort Bend County

3 Provide the identification number used by the governmental entity or state agency to track or identify the contract, and provide a description of the services, goods, or other property to be provided under the contract.
26-R&B-100230
7 new KW trucks

4	Name of Interested Party	City, State, Country (place of business)	Nature of interest (check applicable)	
			Controlling	Intermediary
	Martin, Skip	Cleveland, TX United States	X	
	Sweeten, RC	Cleveland, TX United States	X	
	YEAGER, Dayne	Cleveland , TX United States	X	

5 Check only if there is NO Interested Party.

6 UNSWORN DECLARATION

My name is _____, and my date of birth is _____.

My address is _____, _____, _____, _____, _____.
(city) (state) (zip code) (country)

I declare under penalty of perjury that the foregoing is true and correct.

Executed in _____ County, State of _____, on the _____ day of _____, 20____.
(month) (year)

Signature of authorized agent of contracting business entity
(Declarant)