

STATE OF TEXAS           §  
   §  
 COUNTY OF FORT BEND   §

**AGREEMENT FOR PLAYGROUND EQUIPMENT AND SPLASHPADS AT SUPER DAVE'S  
 ALL ABILITIES PARK  
 BUY BOARD CONTRACT NO. 679-22**

THIS AGREEMENT (hereinafter the "Agreement") is made and entered into by and between Fort Bend County, (hereinafter "County"), a body corporate and politic under the laws of the State of Texas, and Lone Star Recreation of Texas, LLC, (hereinafter "Lone Star Recreation"), a company authorized to conduct business in the State of Texas (may be referred to individually as the "party" and collectively as the "parties").

WITNESSETH

WHEREAS, County desires playground equipment and splashpads for Super Dave's All Abilities Park in Fort Bend County, Texas as will be more specifically described in this Agreement (hereinafter "Services") utilizing Buy Board Contract No. 679-22; and

WHEREAS, Lone Star Recreation represents that it is qualified and desires to perform such services; and

WHEREAS, the parties wish to utilize the Buy Board Cooperative Purchasing Contract No. 679-22 – for Parks and Recreation Equipment, Products, and Installation Services, which is incorporated fully by reference only, for the purchase of the specified products and/or services; and

WHEREAS, this Agreement is not subject to competitive bidding requirements under Section 262.023 of the Texas Local Government Code because this Agreement is pursuant to a Cooperative Purchasing Program in accordance with Chapter 271 of the Texas Local Government Code.

NOW, THEREFORE, in consideration of the mutual covenants and conditions set forth below, the parties agree as follows:

**AGREEMENT**

**Section 1. Recitals**

The recitals set forth above are incorporated herein by reference and made a part of this Agreement.

**Section 2. Scope of Services**

Lone Star Recreation shall render Services in accordance with Lone Star Recreation's Proposals (Quote# 11010-13 and Quote # 11209-06), attached hereto as Exhibit "A" to this Agreement and incorporated by reference for all purposes, utilizing Buy Board Contract No. 679-22.

### **Section 3. Personnel**

- A. Lone Star Recreation represents that it presently has, or is able to obtain, adequate qualified personnel in its employment for the timely performance of the Scope of Services required under this Agreement and that Lone Star Recreation shall furnish and maintain, at its own expense, adequate and sufficient personnel, in the opinion of County, to perform the Scope of Services when and as required and without delays.
- B. All employees of Lone Star Recreation shall have such knowledge and experience as will enable them to perform the duties assigned to them. Any employee of Lone Star Recreation who, in the opinion of County, is incompetent or by his conduct becomes detrimental to the project shall, upon request of County, immediately be removed from association with the project.

### **Section 4. Compensation and Payment**

- A. Lone Star Recreation's fees shall be calculated at the rates set forth in the attached Exhibit A. The Maximum Compensation for the performance of Services within the Scope of Services described in Exhibit A is One Million Eight Hundred Ninety-Two Thousand Five Hundred Nineteen and 65/100 dollars (\$1,892,519.65) utilizing Buy Board Contract No. 679-22. In no case shall the amount paid by County under this Agreement exceed the Maximum Compensation without an approved change order
- B. Lone Star Recreation understands and agrees that the Maximum Compensation stated is an all-inclusive amount and no additional fee, cost or reimbursed expense shall be added whatsoever to the fees stated in the Exhibit(s).
- C. All performance of the Scope of Services by Lone Star Recreation including any changes in the Scope of Services and revision of work satisfactorily performed will be performed only when approved in advance and authorized by County.
- D. County will pay Lone Star Recreation based on the following procedures: Upon completion of the tasks identified in the Scope of Services, Lone Star Recreation shall submit to County two (2) original copies of invoices showing the amounts due for services performed in a form acceptable to County. Lone Star Recreation may submit electronically via: [apauditor@fortbendcountytexas.gov](mailto:apauditor@fortbendcountytexas.gov). County shall review such invoices and approve them within 30 calendar days with such modifications as are consistent with this Agreement and forward same to the Auditor for processing. County shall pay each such approved invoice within thirty (30) calendar days. County reserves the right to withhold payment pending verification of satisfactory work performed.

### **Section 5. Limit of Appropriation**

- A. Lone Star Recreation clearly understands and agrees, such understanding and agreement being of the absolute essence of this Agreement, that County shall have available the total maximum sum of One Million Eight Hundred Ninety-Two Thousand Five Hundred Nineteen and 65/100 dollars (\$1,892,519.65), specifically allocated to fully discharge any and all liabilities County may incur, utilizing Buy Board 679-22.

- B. Lone Star Recreation does further understand and agree, said understanding and agreement also being of the absolute essence of this Agreement, that the total maximum compensation that Lone Star Recreation may become entitled to and the total maximum sum that County may become liable to pay to Lone Star Recreation shall not under any conditions, circumstances, or interpretations thereof exceed One Million Eight Hundred Ninety-Two Thousand Five Hundred Nineteen and 65/100 dollars (\$1,892,519.65).
- C. It is specifically understood and agreed that in the event no funds or insufficient funds are appropriated by Fort Bend County under this Agreement, Fort Bend County shall notify all necessary parties that this Agreement shall thereafter terminate and be null and void on the last day of the fiscal period for which appropriations were made without penalty, liability or expense to Fort Bend County.

**Section 6. Time of Performance or Term**

This Agreement is effective as of the execution of all (“Effective Date”) and shall terminate ten (10) calendar months thereafter, unless sooner terminated in accordance with this Agreement. This Agreement does not automatically renew but may be renewed upon the written agreement of the parties.

**Section 7. Termination**

- A. Termination for Convenience: County may terminate this Agreement at any time upon thirty (30) days written notice issued by the County Judge or the Department Head.
- B. Termination for Default
  - 1. County may terminate the whole or any part of this Agreement for cause in the following circumstances:
    - a. If Lone Star Recreation fails to perform services within the time specified in the Scope of Services or any extension thereof granted by the County in writing;
    - b. If Lone Star Recreation materially breaches any of the covenants or terms and conditions set forth in this Agreement or fails to perform any of the other provisions of this Agreement or so fails to make progress as to endanger performance of this Agreement in accordance with its terms, and in any of these circumstances does not cure such breach or failure to County’s reasonable satisfaction within a period of ten (10) calendar days after receipt of notice from County specifying such breach or failure.
  - 2. If, after termination, it is determined by County that for any reason whatsoever that Lone Star Recreation was not in default, or that the default was excusable, services may continue in accordance with the terms and conditions of this Agreement or the rights and obligations of the parties shall be the same as if the termination had been issued for the convenience of the County in accordance with Section 7A above.

- C. Upon termination of this Agreement, County shall compensate Lone Star Recreation in accordance with Section 4, above, for those services which were provided under this Agreement prior to its termination and which have not been previously invoiced to County. Lone Star Recreation's final invoice for said services will be presented to and paid by County in the same manner set forth in Section 4 above.
- D. If County terminates this Agreement as provided in this Section, no fees of any type, other than fees due and payable at the Termination Date, shall thereafter be paid to Lone Star Recreation.

### **Section 8. Modifications and Waivers**

- A. The parties may not amend or waive this Agreement, except by a written agreement executed by both parties.
- B. No failure or delay in exercising any right or remedy or requiring the satisfaction of any condition under this Agreement, and no course of dealing between the parties, operates as a waiver or estoppel of any right, remedy, or condition.
- C. The rights and remedies of the parties set forth in this Agreement are not exclusive of, but are cumulative to, any rights or remedies now or subsequently existing at law, in equity, or by statute.

### **Section 9. Ownership and Reuse of Documents**

All documents, data, reports, research, graphic presentation materials, etc., developed by Lone Star Recreation as a part of its work under this Agreement, shall become the property of County upon completion of this Agreement, or in the event of termination or cancellation thereof, at the time of payment under Section 4 for work performed. Lone Star Recreation shall promptly furnish all such data and material to County on request.

### **Section 10. Inspection of Books and Records**

Lone Star Recreation will permit County, or any duly authorized agent of County, to inspect and examine the books and records of Lone Star Recreation for the purpose of verifying the amount of work performed under the Scope of Services. County's right to inspect survives the termination of this Agreement for a period of four years.

### **Section 11. Insurance**

- A. Prior to commencement of the Services, Lone Star Recreation shall furnish County with properly executed certificates of insurance which shall evidence all insurance required and provide that such insurance shall not be canceled, except on 30 days' prior written notice to County. Lone Star Recreation shall provide certified copies of insurance endorsements and/or policies if requested by County. Lone Star Recreation shall maintain such insurance coverage from the time Services commence until Services are completed and provide replacement certificates, policies and/or endorsements for any such insurance expiring prior to completion of Services. Lone Star Recreation shall obtain such insurance written on an Occurrence form from such companies having Bests rating of A/VII or better, licensed or approved to transact business in the State of Texas, and shall obtain such insurance of the following types and minimum limits:

1. Workers' Compensation in accordance with the laws of the State of Texas. Substitutes to genuine Workers' Compensation Insurance will not be allowed.
  2. Employers' Liability insurance with limits of not less than \$1,000,000 per injury by accident, \$1,000,000 per injury by disease, and \$1,000,000 per bodily injury by disease.
  3. Commercial general liability insurance with a limit of not less than \$1,000,000 each occurrence and \$2,000,000 in the annual aggregate. Policy shall cover liability for bodily injury, personal injury, and property damage and products/completed operations arising out of the business operations of the policyholder.
  4. Business Automobile Liability coverage applying to owned, non-owned and hired automobiles with limits not less than \$1,000,000 each occurrence combined single limit for Bodily Injury and Property Damage combined.
- B. County and the members of Commissioners Court shall be named as additional insured to all required coverage except for Workers' Compensation and Professional Liability (if required). All Liability policies written on behalf of Lone Star Recreation shall contain a waiver of subrogation in favor of County and members of Commissioners Court. For Commercial General Liability, the County shall be named as an Additional Insured on a Primary & Non-Contributory basis.
- C. If required coverage is written on a claims-made basis, Lone Star Recreation warrants that any retroactive date applicable to coverage under the policy precedes the effective date of the Contract and that continuous coverage will be maintained or an extended discovery period will be exercised for a period of 2 years beginning from the time the work under this Contract is completed.
- D. Lone Star Recreation shall not commence any portion of the work under this Contract until it has obtained the insurance required herein and certificates of such insurance have been filed with and approved by Fort Bend County.
- E. No cancellation of or changes to the certificates, or the policies, may be made without thirty (30) days prior, written notification to Fort Bend County.
- F. Approval of the insurance by Fort Bend County shall not relieve or decrease the liability of the Lone Star Recreation.

## **Section 12. Indemnity**

**LONE STAR RECREATION SHALL INDEMNIFY AND DEFEND COUNTY AGAINST ALL LOSSES, LIABILITIES, CLAIMS, CAUSES OF ACTION, AND OTHER EXPENSES, INCLUDING REASONABLE ATTORNEYS FEES, ARISING FROM ACTIVITIES OF LONE STAR RECREATION, ITS AGENTS, SERVANTS OR EMPLOYEES, PERFORMED UNDER THIS AGREEMENT THAT RESULT FROM THE NEGLIGENT ACT, ERROR, OR OMISSION OF LONE STAR RECREATION OR ANY OF LONE STAR RECREATION'S AGENTS, SERVANTS OR EMPLOYEES. THE PARTIES AGREE THAT THIS INDEMNIFICATION PROVISION SHALL APPLY DURING THE PERFORMANCE OF SERVICES AS WELL AS DURING THE PERORMANCE OF ANY CONTINUING OBLIGATIONS THAT MAY EXIST (IF ANY) AFTER THE EXPIRATION OF THIS AGREEMENT.**

### **Section 13. Confidential and Proprietary Information**

- A. Lone Star Recreation acknowledges that it and its employees or agents may, in the course of performing their responsibilities under this Agreement, be exposed to or acquire information that is confidential to County. Any and all information of any form obtained by Lone Star Recreation or its employees or agents from County in the performance of this Agreement shall be deemed to be confidential information of County ("Confidential Information"). Any reports or other documents or items (including software) that result from the use of the Confidential Information by Lone Star Recreation shall be treated with respect to confidentiality in the same manner as the Confidential Information. Confidential Information shall be deemed not to include information that (a) is or becomes (other than by disclosure by Lone Star Recreation) publicly known or is contained in a publicly available document; (b) is rightfully in Lone Star Recreation's possession without the obligation of nondisclosure prior to the time of its disclosure under this Agreement; or (c) is independently developed by employees or agents of Lone Star Recreation who can be shown to have had no access to the Confidential Information.
  
- B. Lone Star Recreation agrees to hold Confidential Information in strict confidence, using at least the same degree of care that Lone Star Recreation uses in maintaining the confidentiality of its own confidential information, and not to copy, reproduce, sell, assign, license, market, transfer or otherwise dispose of, give, or disclose Confidential Information to third parties or use Confidential Information for any purposes whatsoever other than the provision of Services to County hereunder, and to advise each of its employees and agents of their obligations to keep Confidential Information confidential. Lone Star Recreation shall use its best efforts to assist County in identifying and preventing any unauthorized use or disclosure of any Confidential Information. Without limitation of the foregoing, Lone Star Recreation shall advise County immediately in the event Lone Star Recreation learns or has reason to believe that any person who has had access to Confidential Information has violated or intends to violate the terms of this Agreement and Lone Star Recreation will at its expense cooperate with County in seeking injunctive or other equitable relief in the name of County or Lone Star Recreation against any such person. Lone Star Recreation agrees that, except as directed by County, Lone Star Recreation will not at any time during or after the term of this Agreement disclose, directly or indirectly, any Confidential Information to any person, and that upon termination of this Agreement or at County's request, Lone Star Recreation will promptly turn over to County all documents, papers, and other matter in Lone Star Recreation's possession which embody Confidential Information.
  
- C. Lone Star Recreation acknowledges that a breach of this Section, including disclosure of any Confidential Information, or disclosure of other information that, at law or in equity, ought to remain confidential, will give rise to irreparable injury to County that is inadequately compensable in damages. Accordingly, County may seek and obtain injunctive relief against the breach or threatened breach of the foregoing undertakings, in addition to any other legal remedies that may be available. Lone Star Recreation acknowledges and agrees that the covenants contained herein are necessary for the protection of the legitimate business interest of County and are reasonable in scope and content.
  
- D. Lone Star Recreation in providing all services hereunder agrees to abide by the provisions of any applicable Federal or State Data Privacy Act.

- E. Lone Star Recreation expressly acknowledges that County is subject to the Texas Public Information Act, TEX. GOV'T CODE ANN. §§ 552.001 et seq., as amended, and notwithstanding any provision in the Agreement to the contrary, County will make any information related to the Agreement, or otherwise, available to third parties in accordance with the Texas Public Information Act. Any proprietary or confidential information marked as such provided to County by Lone Star Recreation shall not be disclosed to any third party, except as directed by the Texas Attorney General in response to a request for such under the Texas Public Information Act, which provides for notice to the owner of such marked information and the opportunity for the owner of such information to notify the Attorney General of the reasons why such information should not be disclosed. The terms and conditions of the Agreement are not proprietary or confidential information.

**Section 14. Independent Contractor**

- A. In the performance of work or services hereunder, Lone Star Recreation shall be deemed an independent contractor, and any of its agents, employees, officers, or volunteers performing work required hereunder shall be deemed solely as employees of Lone Star Recreation or, where permitted, of its subcontractors.
- B. Lone Star Recreation and its agents, employees, officers, or volunteers shall not, by performing work pursuant to this Agreement, be deemed to be employees, agents, or servants of County and shall not be entitled to any of the privileges or benefits of County employment.

**Section 15. Notices**

- A. Each party giving any notice or making any request, demand, or other communication (each, a "Notice") pursuant to this Agreement shall do so in writing and shall use one of the following methods of delivery, each of which, for purposes of this Agreement, is a writing: personal delivery, registered or certified mail (in each case, return receipt requested and postage prepaid), or nationally recognized overnight courier (with all fees prepaid).
- B. Each party giving a Notice shall address the Notice to the receiving party at the address listed below or to another address designated by a party in a Notice pursuant to this Section:

County: Fort Bend County  
Attn: County Judge  
401 Jackson St, 1<sup>st</sup> floor  
Richmond, Texas 77469

With a copy to: Fort Bend County Parks and Recreation  
Attn: Parks Director  
301 Jackson St.  
Richmond, Texas 77469

Lone Star Recreation: LONE STAR RECREATION OF TEXAS, LLC  
10701 Corporate Drive, Suite 390  
Stafford, Texas 77477

- C. Notice is effective only if the party giving or making the Notice has complied with subsections 15(A) and 15(B) and if the addressee has received the Notice. A Notice is deemed received as follows:
1. If the Notice is delivered in person or sent by registered or certified mail or a nationally recognized overnight courier, upon receipt as indicated by the date on the signed receipt.
  2. If the addressee rejects or otherwise refuses to accept the Notice, or if the Notice cannot be delivered because of a change in address for which no Notice was given, then upon the rejection, refusal, or inability to deliver.

**Section 16. Compliance with Laws**

Lone Star Recreation shall comply with all federal, state, and local laws, statutes, ordinances, rules and regulations, and the orders and decrees of any courts or administrative bodies or tribunals in any matter affecting the performance of this Agreement, including, without limitation, Worker's Compensation laws, minimum and maximum salary and wage statutes and regulations, licensing laws and regulations. When required by County, Lone Star Recreation shall furnish County with certification of compliance with said laws, statutes, ordinances, rules, regulations, orders, and decrees above specified.

**Section 17. Performance Warranty**

- A. Lone Star Recreation warrants to County that Lone Star Recreation has the skill and knowledge ordinarily possessed by well-informed members of its trade or profession practicing in the greater Houston metropolitan area and Lone Star Recreation will apply that skill and knowledge with care and diligence to ensure that the Services provided hereunder will be performed and delivered in accordance with the highest professional standards.
- B. Lone Star Recreation warrants to County that the Services will be free from material errors and will materially conform to all requirements and specifications contained in the attached Exhibit A.

**Section 18. Assignment and Delegation**

- A. Neither party may assign any of its rights under this Agreement, except with the prior written consent of the other party. That party shall not unreasonably withhold its consent. All assignments of rights by Lone Star Recreation are prohibited under this subsection, whether they are voluntarily or involuntarily, without first obtaining written consent from County.
- B. Neither party may delegate any performance under this Agreement.
- C. Any purported assignment of rights or delegation of performance in violation of this Section is void.

**Section 19. Applicable Law**

The laws of the State of Texas govern all disputes arising out of or relating to this Agreement. The parties hereto acknowledge that venue is proper in Fort Bend County, Texas, for all legal actions

or proceedings arising out of or relating to this Agreement and waive the right to sue or be sued elsewhere. Nothing in the Agreement shall be construed to waive the County's sovereign immunity.

**Section 20. Successors and Assigns**

County and Lone Star Recreation bind themselves and their successors, executors, administrators and assigns to the other party of this Agreement and to the successors, executors, administrators and assigns of the other party, in respect to all covenants of this Agreement.

**Section 21. Third Party Beneficiaries**

This Agreement does not confer any enforceable rights or remedies upon any person other than the parties.

**Section 22. Severability**

If any provision of this Agreement is determined to be invalid, illegal, or unenforceable, the remaining provisions remain in full force, if the essential terms and conditions of this Agreement for each party remain valid, binding, and enforceable.

**Section 23. Publicity**

Contact with citizens of Fort Bend County, media outlets, or governmental agencies shall be the sole responsibility of County. Under no circumstances whatsoever, shall Lone Star Recreation release any material or information developed or received in the performance of the Services hereunder without the express written permission of County, except where required to do so by law.

**Section 24. Captions**

The section captions used in this Agreement are for convenience of reference only and do not affect the interpretation or construction of this Agreement.

**Section 25. Conflict**

In the event there is a conflict between this Agreement and the attached exhibit, this Agreement controls.

**Section 26. Certain State Law Requirements for Contracts** For purposes of section 2252.152, 2271.002, and 2274.002, Texas Government Code, as amended, Lone Star Recreation hereby verifies that Lone Star Recreation and any parent company, wholly owned subsidiary, majority-owned subsidiary, and affiliate:

- A. Unless affirmatively declared by the United States government to be excluded from its federal sanctions regime relating to Sudan or Iran or any federal sanctions regime relating to a foreign terrorist organization, is not identified on a list prepared and maintained by the Texas Comptroller of Public Accounts under Section 806.051, 807.051, or 2252.153 of the Texas Government Code.
- B. If employing ten (10) or more full-time employees and this Agreement has a value of \$100,000.00 or more, Lone Star Recreation does not boycott Israel and is authorized to agree in such contracts not to boycott Israel during the term of such contracts. "Boycott Israel" has the meaning provided in section 808.001 of the Texas Government Code.

- C. If employing ten (10) or more full-time employees and this Agreement has a value of \$100,000.00 or more, Lone Star Recreation does not boycott energy companies and is authorized to agree in such contracts not to boycott energy companies during the term of such contracts. "Boycott energy company" has the meaning provided in section 809.001 of the Texas Government Code.
- D. If employing ten (10) or more full-time employees and this Agreement has a value of \$100,000.00 or more, Lone Star Recreation does not have a practice, policy, guidance, or directive that discriminates against a firearm entity or firearm trade association and is authorized to agree in such contracts not to discriminate against a firearm entity or firearm trade association during the term of such contracts. "Discriminate against a firearm entity or firearm trade association" has the meaning provided in section 2274.001(3) of the Texas Government Code. "Firearm entity" and "firearm trade association" have the meanings provided in section 2274.001(6) and (7) of the Texas Government Code.

**Section 27. Human Trafficking**

BY ACCEPTANCE OF CONTRACT, LONE STAR RECREATION ACKNOWLEDGES THAT FORT BEND COUNTY IS OPPOSED TO HUMAN TRAFFICKING AND THAT NO COUNTY FUNDS WILL BE USED IN SUPPORT OF SERVICES OR ACTIVITIES THAT VIOLATE HUMAN TRAFFICKING LAWS

**Section 28. Entire Agreement**

This executed instrument is understood and intended to be the final expression of the parties' agreement and is a complete and exclusive statement of the terms and conditions with respect thereto, superseding all prior agreements or representations, oral or written, and all other communication between the parties relating to the subject matter of this agreement. Any oral representations or modifications concerning this instrument shall be of no force or effect excepting a subsequent modification in writing signed by all the parties hereto.

**{EXECUTION PAGE FOLLOWS}**

IN WITNESS WHEREOF, the parties hereto have signed or have caused their respective names to be signed to multiple counterparts to be effective upon execution of all parties.

**FORT BEND COUNTY**

KP George  
KP George, County Judge

October 9, 2025  
Date

ATTEST:  
Laura Richard  
Laura Richard, County Clerk

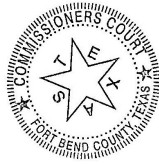

**LONE STAR RECREATION OF TEXAS, LLC**

Eric Edwards  
Authorized Agent- Signature

Eric Edwards  
Authorized Agent- Printed Name

Principal Owner  
Title

9/23/2025  
Date

**APPROVED:**

Darren McCarthy  
Darren McCarthy, Director  
Fort Bend Parks and Recreation

**AUDITOR'S CERTIFICATE**

I hereby certify that funds are available in the amount of \$ 1,892,519.65 to accomplish and pay the obligation of Fort Bend County under this contract.

Robert Ed Sturdivant  
Robert Ed Sturdivant, County Auditor

Exhibit A: Lone Star Recreation's Proposals (Quote# 11010-13 and Quote # 11209-06)

i:\agreements\2025 agreements\purchasing\parks\lone star recreation of texas (25-parks-101000)\agreement for playground equipment and splashpads.super daves all abilities park (kcj - 9.16.2025) v2 9.17.2025

# **EXHIBIT A**

(Lone Star Recreation's Proposal Quote# 11010-13 and  
Lone Star Recreation's Proposal Quote # 11209-06)



# Super Dave's All Abilities Park

1152951-01-10-01 • 03.26.2025





# Super Dave's All Abilities Park

1152951-01-10-02 • 03.26.2025





# Super Dave's All Abilities Park

1152951-01-10-03 · 03.26.2025





## Super Dave's All Abilities Park

1152951-01-10-04 · 03.26.2025





# Super Dave's All Abilities Park

1152951-01-10-05 · 03.26.2025





# Super Dave's All Abilities Park

1152951-01-10-06 · 03.26.2025





# Super Dave's All Abilities Park

1152951-01-10-07 · 03.26.2025





# Super Dave's All Abilities Park

1152951-01-10-08 • 03.26.2025





# Super Dave's All Abilities Park

1152951-01-10-09 · 03.26.2025





# Super Dave's All Abilities Park

1152951-01-10-10 • 03.26.2025





# Super Dave's All Abilities Park

1152951-01-10-11 • 03.26.2025



# ART APPROVAL



PLEASE REVIEW  
AND APPROVE  
THE FOLLOWING:

**Color, Verbiage, Layout/size, and Overall Graphic.**  
I verify that I own or otherwise possess all necessary rights with respect to the user-submitted images, and that the user-submitted images do not infringe, misappropriate, use without authorization, disclose without authorization, or otherwise violate any copyright, trademark, trade secret, other intellectual property right, or a property right of any third party.

This approval confirms all major design work has been completed and accurately reflects the direction specified. This rendering remains a conceptual approximation as custom products are subject to final engineering including, but not limited to, hardware placement and minor changes related to standards and manufacturing capabilities. Each change following this approval will require a change order and impact the delivery date.

SIGNATURE	DATE



Super Dave's All Abilities Park

1152951-01-10-12 · 03.26.2025



# ART APPROVAL



PLEASE REVIEW  
AND APPROVE  
THE FOLLOWING:

**Color, Verbiage, Layout/size, and Overall Graphic.**  
I verify that I own or otherwise possess all necessary rights with respect to the user-submitted images, and that the user-submitted images do not infringe, misappropriate, use without authorization, disclose without authorization, or otherwise violate any copyright, trademark, trade secret, other intellectual property right, or a property right of any third party.

This approval confirms all major design work has been completed and accurately reflects the direction specified. This rendering remains a conceptual approximation as custom products are subject to final engineering including, but not limited to, hardware placement and minor changes related to standards and manufacturing capabilities. Each change following this approval will require a change order and impact the delivery date.

--

SIGNATURE DATE



Super Dave's All Abilities Park

1152951-01-10-13 · 03.26.2025



# ART APPROVAL



PLEASE REVIEW  
AND APPROVE  
THE FOLLOWING:

**Color, Verbiage, Layout/size, and Overall Graphic.**  
I verify that I own or otherwise possess all necessary rights with respect to the user-submitted images, and that the user-submitted images do not infringe, misappropriate, use without authorization, disclose without authorization, or otherwise violate any copyright, trademark, trade secret, other intellectual property right, or a property right of any third party.

This approval confirms all major design work has been completed and accurately reflects the direction specified. This rendering remains a conceptual approximation as custom products are subject to final engineering including, but not limited to, hardware placement and minor changes related to standards and manufacturing capabilities. Each change following this approval will require a change order and impact the delivery date.

SIGNATURE	DATE



Super Dave's All Abilities Park

1152951-01-10-14 · 03.26.2025



# ART APPROVAL



PLEASE REVIEW  
AND APPROVE  
THE FOLLOWING:

**Color, Verbiage, Layout/size, and Overall Graphic.**  
I verify that I own or otherwise possess all necessary rights with respect to the user-submitted images, and that the user-submitted images do not infringe, misappropriate, use without authorization, disclose without authorization, or otherwise violate any copyright, trademark, trade secret, other intellectual property right, or a property right of any third party.

This approval confirms all major design work has been completed and accurately reflects the direction specified. This rendering remains a conceptual approximation as custom products are subject to final engineering including, but not limited to, hardware placement and minor changes related to standards and manufacturing capabilities. Each change following this approval will require a change order and impact the delivery date.

SIGNATURE

DATE



Super Dave's All Abilities Park

1152951-01-10-15 · 03.26.2025



©2025 Landscape Structures. All Rights Reserved.

# ART APPROVAL



PLEASE REVIEW  
AND APPROVE  
THE FOLLOWING:

**Color, Verbiage, Layout/size, and Overall Graphic.**  
I verify that I own or otherwise possess all necessary rights with respect to the user-submitted images, and that the user-submitted images do not infringe, misappropriate, use without authorization, disclose without authorization, or otherwise violate any copyright, trademark, trade secret, other intellectual property right, or a property right of any third party.

This approval confirms all major design work has been completed and accurately reflects the direction specified. This rendering remains a conceptual approximation as custom products are subject to final engineering including, but not limited to, hardware placement and minor changes related to standards and manufacturing capabilities. Each change following this approval will require a change order and impact the delivery date.

SIGNATURE	DATE



Super Dave's All Abilities Park

1152951-01-10-16 · 03.26.2025



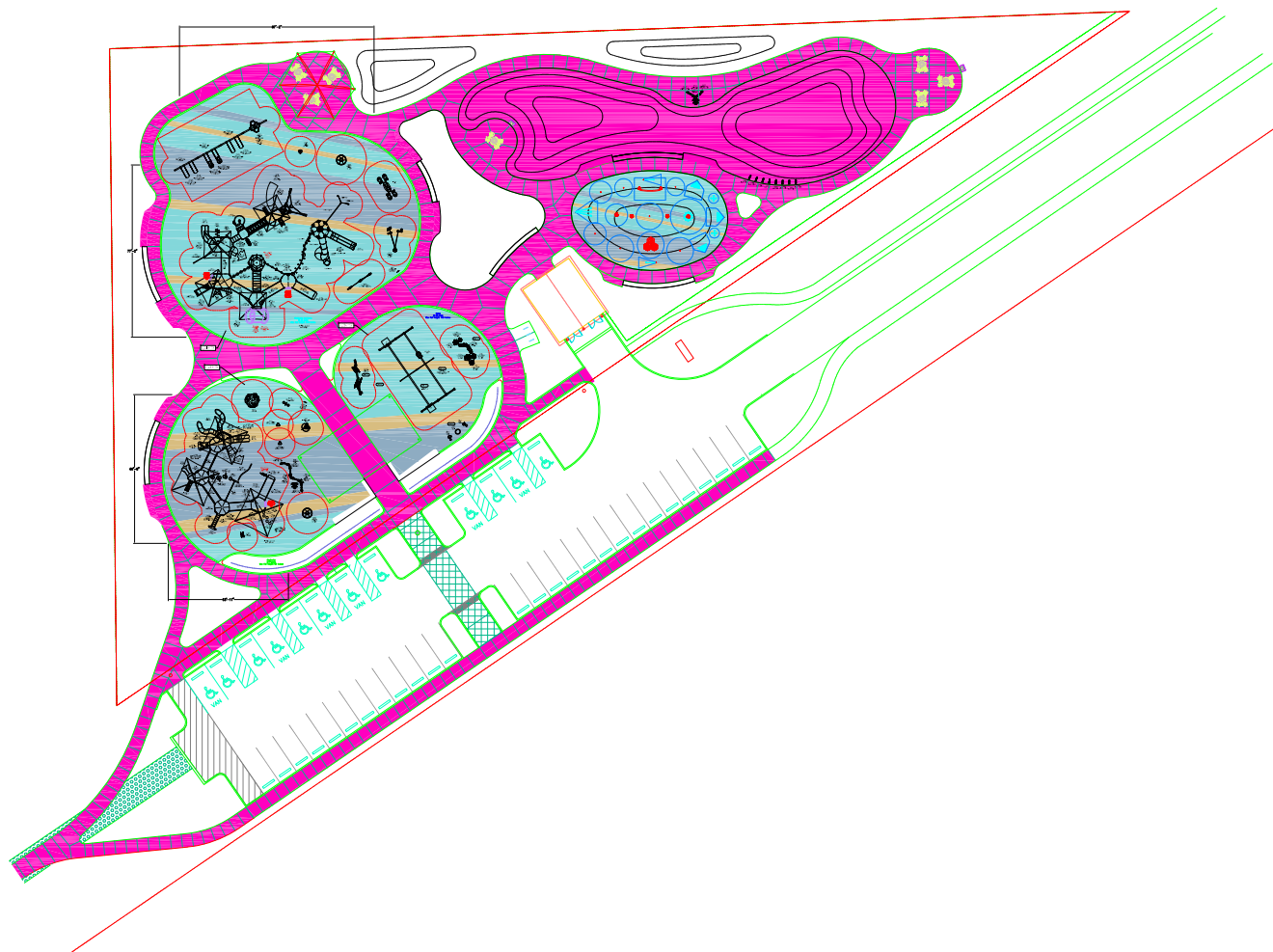

2-5 EQUIPMENT

TOTAL ELEVATED PLAY COMPONENTS	21		
TOTAL ELEVATED COMPONENTS ACCESSIBLE BY RAMP	15	REQUIRED	11
TOTAL ELEVATED COMPONENTS ACCESSIBLE BY TRANSFER	6	REQUIRED	0
TOTAL ACCESSIBLE GROUND LEVEL COMPONENTS SHOWN	13	REQUIRED	0
TOTAL DIFFERENT TYPES OF GROUND LEVEL COMPONENTS	13	REQUIRED	11

5-12 EQUIPMENT

TOTAL ELEVATED PLAY COMPONENTS	32		
TOTAL ELEVATED COMPONENTS ACCESSIBLE BY RAMP	9	REQUIRED	8
TOTAL ELEVATED COMPONENTS ACCESSIBLE BY TRANSFER	13	REQUIRED	8
TOTAL ACCESSIBLE GROUND LEVEL COMPONENTS SHOWN	31	REQUIRED	10
TOTAL DIFFERENT TYPES OF GROUND LEVEL COMPONENTS	19	REQUIRED	19



The site components of this playground are IPEMA certified. This will ensure a level of safety for the equipment that meets or exceeds the ASTM safety standards for playground equipment. ALWAYS SHADES TO BE USED. PLEASE SEE ELEVATION FOR SPECIAL SURFACE HEIGHTS.

THIS PLAY AREA & PLAY EQUIPMENT IS DESIGNED FOR AGES 2-12 YEARS UNLESS OTHERWISE NOTED ON PLAN.

IF THE MANUFACTURERS SPECIFY THAT THE PLAY AREA DOES CONFORM TO THE A.D.A. ACCESSIBILITY STANDARDS, ASSURE AN ACCESSIBLE PROTECTIVE SURFACE IS PROVIDED, AS REQUIRED, ON ALL OF THE CHUTE USE ZONE.

THE CONCEPTUAL PLAN WAS BASED ON INFORMATION AVAILABLE TO US. PRIOR TO CONSTRUCTION VERIFY THE INFORMATION INCLUDING: SITE ELEVATIONS, TOPOGRAPHY, EXISTING UTILITIES, SOIL CONDITIONS, AND CHUTE SLOPES. IN THE FIELD, PLEASE VERIFY ALL DIMENSIONS OF PLAY AREAS, INCLUDING THE WIDTH OF ALL EXISTING UTILITIES EQUIPMENT, AND THE DIMENSIONS PRIOR TO CONSTRUCTION. YOU SHOULD MAKE THE FINAL ADJUSTMENTS.

CHOOSE A PROTECTIVE SURFACE MATERIAL THAT HAS A MINIMUM HEIGHT VALUE TO MEET THE MINIMUM HEIGHT OF THE USER'S HEAD (FOR ASTM PLAY) STANDARD. CONSIDER SAFETY PERFORMANCE SPECIFICATIONS FOR PROTECTIVE SURFACE FOR PUBLIC USE. SELECT A SURFACE MATERIAL. THE SURFACE MUST BE NEARLY FLAT IN THE USE ZONE AND SHOULD BE MAINTAINED TO A SLOPE OF 1:10. PROVIDE A 1:10 SLOPE TO A STORM SEWER OR A TRASH BIN.

AREA OF ACCESSIBLE/PROTECTIVE SURFACE (FOOTED) - (N/A) - (SUGGESTED)

DESIGNED BY: NKK

COPYRIGHT: 5/25/25  
 INN LANDSCAPE STRUCTURES, INC.  
 880 W. WHEELER BLVD. - FARGO, ND 58103  
 TEL: 701-785-2200 FAX: 701-785-2201

5/27/25	1152951-01-03	115
7/14/25	1152951-01-04	115
4/15/21	1152951-01-01	115

Date Previous Drawing # Initials



Super Dave's All Abilities Park  
 Fulshear, TX

Lone Star Recreation of Texas  
 Vanessa Zelaya

SYSTEM TYPE: PlayBooster  
 DRAWING #: 1152951-01-10





**Lone Star Recreation of Texas, LLC.**

10701 Corporate Drive Suite 390  
Stafford, TX 77477

Phone: 281-970-9010

**PROPOSAL**

**Quote # 11010-13**

Page 1 of 3

**Contact:** Tyler Kendziora  
**Company:** Fort Bend County  
**Phone:** 346-481-6938  
**Email:** Tyler.Kendziora@fortbendcountytexas.gov

**Ship To:** Landscape Structures, Inc.  
Certified Installer

**Bill To:** Fort Bend County  
301 Jackson St, Suite 201  
Richmond, TX 77469

**Installation Site:** Super Dave's All Abilities Park - FAAP  
4200 Katy Fulshear Rd.  
Katy, TX 77494

**Design Number:** 1152951-01-10

**Date:** 08/05/2025  
**Proposal Expires:** 09/30/2025

**Terms**  
INCO Terms: F.O.B. Manufacturing Plant  
Estimated Mfg. Lead Time: 4-6 weeks ARO  
Payment Terms:  
**Equipment:** Ref. Schedule of Payments  
**Installation:** Ref. Schedule of Payments  
**Surface:** Ref. Schedule of Payments

**Proposal Prepared By**  
**Contact:** Sarah Campise  
**Phone:** 281-970-9010  
**Email:** sarah.campise@LoneStarRecreation.com

**Sales**  
**Contact:** Vanessa Zelaya  
**Phone:** 281-970-9010  
**Email:** vanessa.zelaya@LoneStarRecreation.com

QTY	ITEM NO.	DESCRIPTION	UNIT PRICE	EXTENDED AMT
1	1152951-01-10	PlayBooster® (2-5 years)	\$ 149,999.00	\$ 149,999.00
1	200677A	Wee Planet Climber DB	\$ 3,384.00	\$ 3,384.00
1	233057B	DigiRider Butterfly DB	\$ 1,885.00	\$ 1,885.00
1	164075B	Double Bobble Rider DB	\$ 2,848.00	\$ 2,848.00
1	295696A	ReviRock Bouncer DB Only	\$ 5,974.00	\$ 5,974.00
2	152179A	Saddle Spinner DB 12" Height	\$ 1,020.00	\$ 2,040.00
1	168099A	Cozy Dome DB	\$ 6,098.00	\$ 6,098.00
1	1152951-01-10	Sensory Play Center w/Fun Mirror Panel, Kaleidospin Panel and Xylofun/Alphamaze Panel	\$ 18,494.00	\$ 18,494.00
1	182503A	Welcome Sign (LSI Provided) Ages 2-5 years DB		
1	307431A	Fox Den Hangouts DB Only	\$ 21,409.00	\$ 21,409.00
1	237103A	Facet Stepper 14" Height DB Only	\$ 1,365.00	\$ 1,365.00
3	237104A	Facet Stepper 22" Height DB Only	\$ 2,957.00	\$ 8,871.00
1	237105A	Facet Stepper 28" Height DB Only	\$ 4,399.00	\$ 4,399.00
1	237934B	Facet Balance Beam Double DB Only	\$ 2,998.00	\$ 2,998.00
1	194663A	ZipKrooz 34' w/Aluminum Posts DB	\$ 16,388.00	\$ 16,388.00
1	196213A	ZipKrooz Assisted Additional Bay 34' w/Aluminum Posts DB	\$ 14,163.00	\$ 14,163.00
1	214443A	Rhapsody Goblet Drum DB	\$ 2,019.00	\$ 2,019.00
1	214445A	Rhapsody Kettle Drum DB	\$ 2,019.00	\$ 2,019.00
1	214444A	Rhapsody Kundu Drum DB	\$ 2,019.00	\$ 2,019.00
1	1152951-01-10	PlayBooster® (5-12 years)	\$ 236,973.00	\$ 236,973.00
1	254626A	Super Netplex 12' Tower	\$ 105,926.00	\$ 105,926.00
1	307426A	Forma™ Sol Spinner DB Only	\$ 9,373.00	\$ 9,373.00
1	247179A	Curva Spinner DB Only	\$ 2,581.00	\$ 2,581.00
1	186490A	We-saw DB Only	\$ 14,611.00	\$ 14,611.00
1	295695A	ReviWheel Spinner DB Only	\$ 6,850.00	\$ 6,850.00
1	160213A	Power Lifter Double Bay DB - Accessible Power Lifter	\$ 5,722.00	\$ 5,722.00
1	1152951-01-10	Single Post Swing Frame w/(2) Additional Bays, (4) Belt Seats, (1) Friendship Swing and (2) Molded Bucket Seat (5-12 yrs) w/Harness, ProGuard Chains	\$ 11,413.00	\$ 11,413.00
1	182503C	Welcome Sign (LSI Provided) Ages 5-12 years DB		
1	251573A	Rhapsody® Vibra® Chimes - Full Set DB	\$ 11,495.00	\$ 11,495.00
1	1152951-01-09	Sensory Play Center w/Rain Sound Wheel Panel	\$ 7,195.00	\$ 7,195.00

**SUBTOTAL \$ 678,511.00**

Pricing is for the above listed equipment only: NO installation, subgrade, drainage, additional contract terms, additions or deletion, change orders, insured addendum, off loading of equipment, storage of product, site security, retainage, or any applicable taxes, bonds, permits or freight are included unless listed as separate line items.

Individual line items invoiced according to Schedule of Payments. Freight charges will be included with initial invoice.

Tax Exemption Certificate must be supplied with order if applicable

Change orders, cancellation, and/or rescheduling of services will be subject to available schedule and payment for incurred time, expenses, freight, and/or fees.

LSRT reserves the right to apply payments to past due invoices first before applying payments to specific orders.

1.5% per month late payment fee will be applied for late payments

LSRT Terms and Conditions apply unless Subcontract is on file.



**Lone Star Recreation of Texas, LLC.**

10701 Corporate Drive Suite 390

Stafford, TX 77477

Phone: 281-970-9010

**PROPOSAL**

Quote # **11010-13**

Page 2 of 3

**Contact:** Tyler Kendziora  
**Company:** Fort Bend County  
**Phone:** 346-481-6938  
**Email:** Tyler.Kendziora@fortbendcountytexas.gov

**Ship To:** Landscape Structures, Inc.  
 Certified Installer

**Bill To:** Fort Bend County  
 301 Jackson St, Suite 201  
 Richmond, TX 77469

**Installation Site:** Super Dave's All Abilities Park - FAAP  
 4200 Katy Fulshear Rd.  
 Katy, TX 77494

**Design Number:** 1152951-01-10

**Date:** 08/05/2025  
**Proposal Expires:** 09/30/2025

**Terms**  
 INCO Terms: F.O.B. Manufacturing Plant  
 Estimated Mfg. Lead Time: 4-6 weeks ARO  
 Payment Terms:

**Equipment:** Ref. Schedule of Payments  
**Installation:** Ref. Schedule of Payments  
**Surface:** Ref. Schedule of Payments

**Proposal Prepared By**  
**Contact:** Sarah Campise  
**Phone:** 281-970-9010  
**Email:** sarah.campise@LoneStarRecreation.com

**Sales**  
**Contact:** Vanessa Zelaya  
**Phone:** 281-970-9010  
**Email:** vanessa.zelaya@LoneStarRecreation.com

QTY	ITEM NO.	DESCRIPTION	% of PRICE	CONTRACT PRICE
1	INSTALLATION	Installation of Landscape Structures equipment referenced above by Manufacturer Trained and Certified CPSI Installer w/ 12 month labor warranty	\$ 237,475.00	\$ 237,475.00
1	SURFACE	Delivered & installed approx. 19,079sf w/ Flush Edge Finish 5419sf @ 2.75", 3,750sf @ 4.25", 9,910sf @ 6" 50% Standard Color / 50% Black w/ Aromatic Binder Subbase: 4" Stone Base Included Drainage: Not Included (By Others) Dumpster: Included Security: Included **Price does not include on-site testing	\$ 657,669.00	\$ 657,669.00

**By signing this proposal, the customer is agreeing to the scope of work and terms.**

Accepted by Customer \_\_\_\_\_ Date \_\_\_\_\_

Print Name \_\_\_\_\_ PO/Ref. # \_\_\_\_\_ Title \_\_\_\_\_

EQUIPMENT	\$	678,511.00
INSTALLATION	\$	237,475.00
SURFACE	\$	657,669.00
BUYBOARD #679-22	\$	(78,682.05)
FREIGHT	\$	21,650.00
SALES TAX		Exempt
<b>TOTAL</b>	<b>\$</b>	<b>1,516,622.95</b>

Pricing is for the above listed equipment only: NO installation, subgrade, drainage, additional contract terms, additions or deletion, change orders, insured addendum, off loading of equipment, storage of product, site security, retainage, or any applicable taxes, bonds, permits or freight are included unless listed as separate line items.

Individual line items invoiced according to Schedule of Payments. Freight charges will be included with initial invoice.

Tax Exemption Certificate must be supplied with order if applicable

Change orders, cancellation, and/or rescheduling of services will be subject to available schedule and payment for incurred time, expenses, freight, and/or fees.

LSRT reserves the right to apply payments to past due invoices first before applying payments to specific orders.

1.5% per month late payment fee will be applied for late payments

LSRT Terms and Conditions apply unless Subcontract is on file.



**Lone Star Recreation of Texas, LLC.**

10701 Corporate Drive Suite 390  
 Stafford, TX 77477  
 Phone: 281-970-9010

**SCHEDULE OF PAYMENTS**

**Quote # 11010-13**  
 Page 3 of 3

**Contact:** Tyler Kendziora  
**Company:** Fort Bend County  
**Phone:** 346-481-6938  
**Email:** Tyler.Kendziora@fortbendcountytexas.gov

**Ship To:** Landscape Structures, Inc.  
 Certified Installer

**Bill To:** Fort Bend County  
 301 Jackson St, Suite 201  
 Richmond, TX 77469

**Installation Site:** Super Dave's All Abilities Park - FAAP  
 4200 Katy Fulshear Rd.  
 Katy, TX 77494

**Design Number:** 1152951-01-10

**Date:** 08/05/2025  
**Proposal Expires:** 09/30/2025

**Terms**  
 INCO Terms: F.O.B. Manufacturing Plant  
 Estimated Mfg. Lead Time: 4-6 weeks ARO  
 Payment Terms:  
**Equipment:** Ref. Schedule of Payments  
**Installation:** Ref. Schedule of Payments  
**Surface:** Ref. Schedule of Payments

**Proposal Prepared By**  
**Contact:** Sarah Campise  
**Phone:** 281-970-9010  
**Email:** sarah.campise@LoneStarRecreation.com

**Sales**  
**Contact:** Vanessa Zelaya  
**Phone:** 281-970-9010  
**Email:** vanessa.zelaya@LoneStarRecreation.com

Schedule of Project Payments	Invoice #	Due	Total Value	% of Value	Paid	Balance
<b>Equipment</b>			\$ 678,511.00			
Deposit	30%	with order		\$ 203,553.30		\$ 203,553.30
Equipment Balance	70%	Net 30 from shipment		\$ 474,957.70		\$ 474,957.70
<b>Installation</b>			\$ 237,475.00			
Mobilization	30%	30 days prior to schedule		\$ 71,242.50		\$ 71,242.50
Installation Balance	70%	Net 15 days from completion		\$ 166,232.50		\$ 166,232.50
<b>Surface</b>			\$ 657,669.00			
Surface -PIP Mobilization	30%	30 days prior to schedule		\$ 69,143.70		\$ 69,143.70
Surface - PIP Balance	70%	Net 15 days from completion		\$ 161,335.30		\$ 161,335.30
<b>Discounts</b>			\$ (78,682.05)			
BUYBOARD #679-22	100%	With Final Bill		\$ (78,682.05)		\$ (78,682.05)
<b>Freight</b>			\$ 21,650.00			
Freight	100%	with order		\$ 21,650.00		\$ 21,650.00
			<b>\$ 1,516,622.95</b>	<b>\$ 1,089,432.95</b>	<b>\$ -</b>	<b>\$ 1,089,432.95</b>

## ADDITIONAL TERMS AND CONDITIONS

**Entire Agreement:** This document, including the proposal and any referenced attachments in the proposal, if any, contains the entire agreement and understanding between the parties with respect to the transaction contemplated. This document sets forth all of the promises, agreements, conditions, and understandings between the parties respecting the subject matter hereof, and replaces and supersedes all negotiations, conversations, discussions, correspondence, memorandums, and oral agreements between the parties, as well as any prior writings. Except as set forth in this document, including any attached exhibits, if any, there are no other agreements, representations, warranties, or covenants by or among the parties hereto with respect to the subject matter hereof. This document, including any attached exhibits, if any, supersedes all other agreements, written or oral, between the parties with respect to the transaction contemplated.

**Modification:** No alteration, amendment, modification, or waiver of any provision of this Agreement shall be valid or effective unless it is in writing and signed by all parties. No oral agreement or course of conduct to the contrary, shall be deemed an alteration, amendment, modification, waiver, or cancellation. No evidence of any alteration, amendment, modification, or waiver shall be offered or received in evidence in any proceeding, mediation, or litigation between the parties hereto arising out of or affecting this Agreement, or the rights or obligations of the parties hereunder, unless such alteration, amendment, modification, or waiver is in writing, duly executed by both parties. Any waiver or consent shall be effective only in the specific instance and for the purpose for which it was given.

**Severability:** If any provision of this Agreement is determined to be invalid or not enforceable, or is prohibited by law for any reason, the invalidity shall not affect the validity of the remaining provisions of this Agreement. The rest of the Agreement will be unaffected.

**No Waiver of Rights:** No waiver by any party of any of its rights or remedies hereunder shall be considered a waiver of any other subsequent right or remedy of that party. The waiver by any party of a breach of any provision of this Agreement shall not be taken or held to be a waiver of the provision itself. Any course of performance shall not be deemed to amend or limit any provision of this Agreement. The failure of any party at any time to require performance by another party of any provision of this Agreement shall not affect in any way the full right to require the performance at any subsequent time. No delay or omission in the exercise of enforcement by either party of any rights or remedies shall ever be construed as a waiver of any right or remedy of that party. No exercise or enforcement of any rights or remedies shall ever be held to exhaust any right or remedy of any party. No action taken pursuant to this Agreement, including any investigation by or on behalf of any party, shall be deemed to constitute a waiver by the party taking such action of compliance with any representation, warranty, covenant, or agreement contained herein or therein and in any documents delivered in connection herewith or therewith. Forbearance or neglect on the part of either party to insist upon strict compliance with the terms of this Agreement shall not be construed as or constitute a waiver thereof.

**Relationship of Parties:** Nothing contained in this Agreement shall be deemed or construed by the parties, or by any third party, to create the relationship of employer/employee, partnership, or joint venture between the parties hereto, it being understood and agreed that no provision contained herein shall be deemed to create any relationship between the parties hereto other than as client and independent contractor.

**Compliance with Laws:** The parties hereto shall each comply with the provisions of all applicable federal, state, county, and local laws, ordinances, regulations, and codes.

**Collaborative Dispute Resolution:** The parties hereto shall cooperate with each other to affect the purpose and intent of this Agreement. If a dispute arises concerning this Agreement that cannot be resolved collaboratively, either with or without the assistance of collaborative counsel, the parties will try in good faith to settle the dispute through mediation conducted by a mediator to be mutually selected. The parties will share the cost of the mediator equally, but each party shall remain solely responsible for their own attorneys' fees and costs. The parties will cooperate fully with the mediator and will attempt to reach a mutually satisfactory resolution of the dispute. If the dispute is not resolved within thirty (30) days after it is referred to the mediator, the parties agree that the dispute can proceed to the courts of Harris County, Texas, governed by the laws of the State of Texas for Collaborative Law.

**Governing Law:** This Agreement, and the rights and obligations of the parties hereunder, is being executed and delivered, and is intended to be performed in the State of Texas. Except to the extent that the laws of the United States may apply to the terms hereof, the substantive laws of the State of Texas applicable to contracts made and to be performed wholly within Texas, without regard to any choice or

conflict of laws rules, shall govern the validity, construction, enforcement, and interpretation of this Agreement. Any litigation arising from this Agreement will be brought in the courts of Harris County.

**Attorneys' Fees:** Excluding mediation, in the event that an action, litigation, or proceeding results from or arises out of this Agreement or the performance thereof, including any appeal or the collection of any judgment, the parties agree to reimburse the prevailing party's reasonable attorney's fees, court costs, and all other expenses, whether or not taxable by the court as costs, in addition to any other relief to which the prevailing party may be entitled, as allowable by law. A prevailing party is defined as a party who secures a judgment in its own favor through a legal process other than mediation.

**Successors and Assigns:** Except as specifically provided in this Agreement, no party may assign, delegate, or transfer any of its rights or obligations under this Agreement, in whole or in part, without the prior written consent of the other, which consent will not be unreasonably withheld. The terms hereof are contractual in nature and are not mere recitals, and the obligations created by this Agreement shall be binding upon the successors, legal representatives, and permitted assigns of the parties hereto, forever.

**Force Majeure:** Neither party shall be liable, nor held in breach of contract, for any loss, damage, and/or any delay in performance that may be suffered as a direct or indirect result of either party being prevented, hindered, or delayed in its performance by circumstances beyond that party's reasonable control due to force majeure, including among others, strikes; lock outs, accidents; trade or labor disputes; natural disasters, including explosions, fire, flood, storm, wind, or drought; war, terrorism, riots, civil commotion, government action, embargoes, and/or acts of civil or military authorities; shortages of transportation, facilities, fuel, energy, labor, or materials; acts of God (specifically including hurricanes and inclement weather that shuts down city services); or any delay or failure resulting from a cause or causes outside either party's reasonable control. If timely completion is prevented by any cause of force majeure, then such failure or delay shall not constitute default.

**Escalation:** During the performance of this agreement, if the price of materials, equipment or energy are significantly increased, through no fault of Lone Star Recreation of Texas, the price shall be equitably adjusted by an amount reasonably necessary to cover any such significant increases. As used herein, a significant price increase shall mean any increase exceeding 5% from the date of the contract signing. Such price escalations shall be documented through change order, quotes, invoices, and/or receipts in accordance with the agreed contract procedure. Where the delivery of material, equipment, or energy is delayed, through no fault of the contractor, as a result of the shortage or unavailability, contractor shall not be liable for any additional costs or damages associated with such delay(s).

**Gender and Numbers:** Unless the context clearly indicates, whenever used, the singular shall include the plural, the plural the singular, and the use of any gender shall include all genders.

**No Third-Party Rights:** This Agreement is solely for the benefit of the parties hereto and their respective successors and assigns, if any, and no other person or entity shall have any right, benefit, priority, or interest hereunder, or because of the existence of this Agreement.

**Headings:** The section headings contained in this Agreement are for convenience and reference purposes only and shall not affect the meaning, interpretation, or construction of this Agreement, and in no way define, describe, extend, or limit the scope or intent of this Agreement, or the intent of any provisions hereof.

**Voluntary Agreement & Advice of Counsel:** The parties confirm and agree that each (i) has relied on its own judgment and has not been induced to sign or execute this Agreement by promises, agreements, or representations not expressly stated herein, (ii) has freely and willingly executed this Agreement and hereby expressly disclaims reliance on any fact, promise, undertaking or representation made by any other party, save and except for the express agreements and representations contained in this Agreement, (iii) was not in a significantly disparate bargaining position with regard to any other party, and (iv) has been represented by legal counsel in this matter or has voluntarily waived that right.

**Multiple parts:** This Agreement may be executed by the parties hereto in any number of separate counterparts, each and all of which taken together shall be deemed for all purposes to be one agreement. It shall not be necessary in making proof of this Agreement to produce or account for more than one counterpart signed by the party to be charged.

**Electronic Signatures:** This Agreement may be executed by the parties hereto with electronic signatures, each of which shall be deemed for all purposes to be an original signature. It shall not be necessary in making proof of this Agreement to produce or account for an original signature made with a traditional ink writing instrument.



Landscape Structures Inc. (“Manufacturer”) warrants that all playstructures and/or equipment sold will conform in kind and in quality to the specifications manual for the products identified in the Acknowledgment of Order and will be free of defects in manufacturing and material. Manufacturer further warrants:

**100-Year Limited Warranty** On all PlayBooster® and PlayShaper® aluminum posts, stainless steel fasteners, clamps, beams and caps against structural failure due to corrosion/natural deterioration or manufacturing defects, and on PlayBooster steel posts against structural failure due to material or manufacturing defects.

**15-Year Limited Warranty** On all Evos® and Weevos® steel arches, all plastic components (including TuffTimbers™ edging), all aluminum and steel components not covered above, Mobius® climbers, Rhapsody® Outdoor Musical Instruments, decks and TenderTuff™ coatings (except Wiggle Ladders, Chain Ladders and Swing Chain) against structural failure due to material or manufacturing defects.

**10-Year Limited Warranty** On concrete products against structural failure due to natural deterioration or manufacturing defects. Does not cover minor chips, hairline cracks or efflorescence.

**8-Year Limited Warranty** On Aeronet® climbers and climbing cables against defects in materials or manufacturing defects.

**5-Year Limited Warranty** On Rhapsody cables and mallets against defects in materials or manufacturing defects and on polycarbonate panels against defects in materials or manufacturing defects.

**3-Year Limited Warranty** On all other parts, i.e. all swing seats and hangers, all swing chain and cables, ZipKrooz® cables, Track Ride trolleys and bumpers, Mobius Climber handholds, Wiggle Ladders, Chain Ladders, all rocking equipment including Sway Fun® gliders, belting material, LSI Flexx™ flexible cable netting, HeathBeat® resistance mechanisms, Seesaws, etc., against failure due to corrosion/natural deterioration or manufacturing defects.

The environment near a saltwater coast can be extremely corrosive. Some corrosion and/or deterioration is considered “normal wear” in this environment. Product installed within 500 yards (457 meters) of a saltwater shoreline will only be covered for half the period of the standard product warranty, up to a maximum of five years, for defects caused by corrosion. Products installed in direct contact with saltwater or that are subjected to salt spray are not covered by the standard warranty for any defects caused by corrosion.

This warranty does not include any cosmetic issues or wear and tear from normal use of the product, or misuse or abuse of the product. It is valid only if the playstructures and/or equipment are erected to conform with Landscape Structures’ installation instructions and maintained according to the maintenance procedures furnished by Landscape Structures Inc.

## 2025 Play Equipment Warranty

You have our word.

All the warranties commence on date of Manufacturer’s invoice. Should any failure to conform to the above express warranties appear within the applicable warranty period, Manufacturer shall, upon being notified in writing promptly after discovery of the defect and within the applicable warranty period, correct such nonconformity either by repairing any defective part or parts, or by making available a replacement part within 60 days of written notification. Manufacturer shall deliver the repaired or replacement part or parts to the site free of charge, but will not be responsible for providing labor or the cost of labor for the removal of the defective part or parts, the installation of any replacement part or parts or for disposal costs of any part or parts. Replacement parts will be warranted for the balance of the original warranty.

THIS WARRANTY IS EXCLUSIVE AND IN LIEU OF ALL OTHER WARRANTIES, WHETHER EXPRESSED OR IMPLIED, INCLUDING BUT NOT LIMITED TO ANY WARRANTY OF MERCHANTABILITY OR OF FITNESS FOR A PARTICULAR PURPOSE.

ANY SURETY BONDS ISSUED PURSUANT TO ANY CONTRACT OR SELLER’S INVOICE SHALL NOT INCLUDE COVERAGE FOR THIS GUARANTEE OR WARRANTY BEYOND ONE YEAR.

The remedies hereby provided shall be the exclusive and sole remedies of the purchaser. Manufacturer shall not be liable for any direct, indirect, special, incidental or consequential damages.

Manufacturer neither assumes nor authorizes any employee, representative or any other person to assume for Manufacturer any other liability in connection with the sale or use of the structures sold, and there are no oral agreements or warranties collateral to or affecting this agreement. The warranties stated above are valid only if the structures and/or equipment are erected in conformance with Landscape Structures’ installation instructions and maintained according to the maintenance procedures furnished by Landscape Structures Inc.; have been subjected to normal use for the purpose for which the goods were designed; have not been exposed to saltwater or salt spray; have not been subject to misuse, negligence, vandalism, or accident; have not been subjected to addition or substitution of parts; and have not been modified, altered, or repaired by persons other than Manufacturer or Manufacturer’s designees in any respect which, in the judgement of Manufacturer, affects the condition or operation of the structures.

To make a claim, send your written statement of claim, along with the original job number or invoice number to: Landscape Structures Inc. 601 7th Street South, Delano, Minnesota, 55328-8605.

Signed:  President Date: 01/01/2025





Landscape Structures Inc. ("Manufacturer") warrants that all equipment sold will conform in kind and in quality to the specifications manual for the products identified in the Acknowledgment of Order and will be free of defects in manufacturing and material. Manufacturer further warrants:

**20-Year Limited Warranty** On all SkyWays® and CoolToppers® steel components against structural failure due to material or manufacturing defects.

**10-Year Limited Warranty** On SkyWays® and CoolToppers® fabric and thread against failure from significant fading, deterioration, breakdown, mildew, outdoor heat, cold or discoloration. This warranty is limited to the design loads as stated in the manual, and applies to standard colors only.

**3-Year Limited Warranty** On all other parts, including Rapid Release, against failure due to corrosion/natural deterioration or manufacturing defects.

The environment near a saltwater coast can be extremely corrosive. Some corrosion and/or deterioration is considered "normal wear" in this environment. Product installed within 500 yards (457 meters) of a saltwater shoreline will only be covered for half the period of the standard product warranty, up to a maximum of five years, for defects caused by corrosion. Products installed in direct contact with saltwater or that are subjected to salt spray are not covered by the standard warranty for any defects caused by corrosion.

This warranty does not include any cosmetic issues or wear and tear from normal use of the product, or misuse or abuse of the product. It is valid only if the equipment is erected to conform with Landscape Structures' installation instructions and maintained according to the maintenance procedures furnished by Landscape Structures Inc. Maintenance is particularly critical in regions where dirt and/or sand may cause abrasion of the fabric.

This warranty is void if conditions exceed local building codes.



## 2025 SkyWays® and CoolToppers® Shade Warranty

You have our word.

All the warranties commence on date of Manufacturer's invoice. Should any failure to conform to the above express warranties appear within the applicable warranty period, Manufacturer shall, upon being notified in writing promptly after discovery of the defect and within the applicable warranty period, correct such nonconformity either by repairing any defective part or parts, or by making available a replacement part within 60 days of written notification. Manufacturer shall deliver the repaired or replacement part or parts to the site free of charge, but will not be responsible for providing labor or the cost of labor for the removal of the defective part or parts, the installation of any replacement part or parts or for disposal costs of any part or parts. Replacement parts will be warranted for the balance of the original warranty.

THIS WARRANTY IS EXCLUSIVE AND IN LIEU OF ALL OTHER WARRANTIES, WHETHER EXPRESSED OR IMPLIED, INCLUDING BUT NOT LIMITED TO ANY WARRANTY OF MERCHANTABILITY OR OF FITNESS FOR A PARTICULAR PURPOSE.

ANY SURETY BONDS ISSUED PURSUANT TO ANY CONTRACT OR SELLER'S INVOICE SHALL NOT INCLUDE COVERAGE FOR THIS GUARANTEE OR WARRANTY BEYOND ONE YEAR.

The remedies hereby provided shall be the exclusive and sole remedies of the purchaser. Manufacturer shall not be liable for any direct, indirect, special, incidental or consequential damages.

Manufacturer neither assumes nor authorizes any employee, representative or any other person to assume for Manufacturer any other liability in connection with the sale or use of the structures sold, and there are no oral agreements or warranties collateral to or affecting this agreement. The warranties stated above are valid only if the structures and/or equipment are erected in conformance with Landscape Structures' installation instructions and maintained according to the maintenance procedures furnished by Landscape Structures Inc.; have been subjected to normal use for the purpose for which the goods were designed; have not been exposed to saltwater or salt spray; have not been subject to misuse, negligence, vandalism, or accident; have not been subjected to addition or substitution of parts; and have not been modified, altered, or repaired by persons other than Manufacturer or Manufacturer's designees in any respect which, in the judgement of Manufacturer, affects the condition or operation of the structures.

To make a claim, send your written statement of claim, along with the original job number or invoice number to: Landscape Structures Inc. 601 7th Street South, Delano, Minnesota, 55328-8605.

Signed:  President Date: 01/01/2025



**PROUDLY PRESENTED BY**

Vanessa Zelaya  
Lone Star Recreation Of Texas  
vanessa.zelaya@lonestarrecreation.com  
(281) 970-9010

**Super Dave's All Abilities Park**

Design# 1158311-02-03 3/20/25

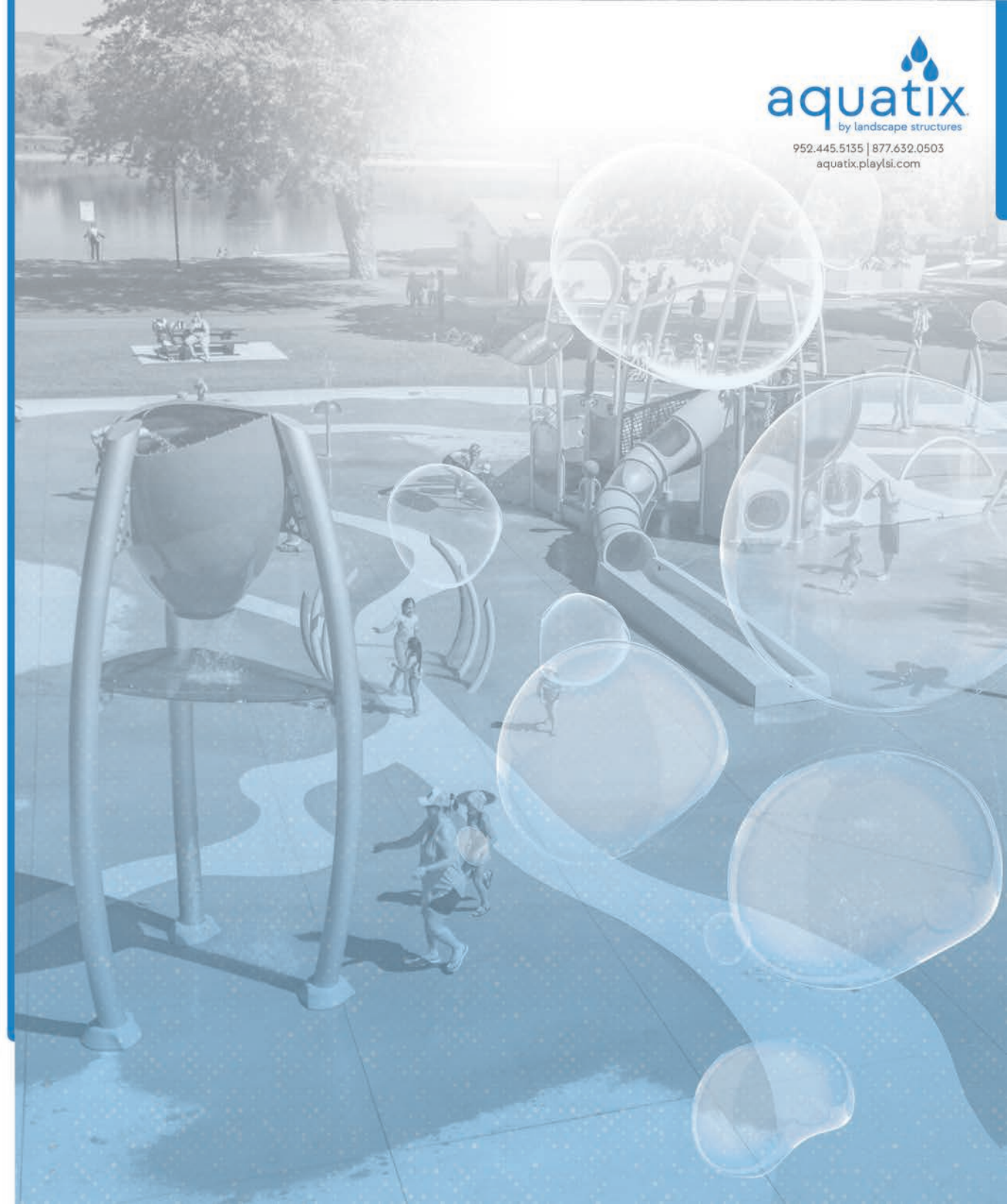

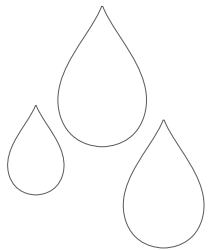

## Super Dave's All Abilities Park

Design# 1158311-02-03 3/20/25

©2025 Aquatix by Landscape Structures. All Rights Reserved | [aquatix.playlsi.com](http://aquatix.playlsi.com)



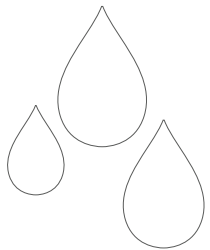

## Super Dave's All Abilities Park

Design# 1158311-02-03 3/20/25

©2025 Aquatix by Landscape Structures. All Rights Reserved | [aquatix.playlsi.com](http://aquatix.playlsi.com)



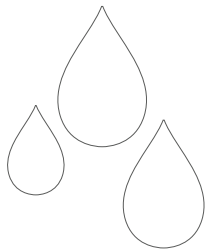

## Super Dave's All Abilities Park

Design# 1158311-02-03 3/20/25

©2025 Aquatix by Landscape Structures. All Rights Reserved | [aquatix.playlsi.com](http://aquatix.playlsi.com)





## INCLUSIVE PLAY HIGHLIGHTS

**W**ater, being naturally inclusive, combined with splash play bring together people of all ages and abilities in a world of fun, learning and sensory exploration. Aquatix innovative water features allow for hands-on education tailored to every development stage. The designers at Aquatix work to deliver an educational, exploratory design that encourages physical and social development, with the ability to grow confidence while engaging in the play elements around them. This inclusive approach not only enhances community connection but also ensures there's something for everyone, making it a vibrant hub for social interaction, relaxation and unforgettable memories.

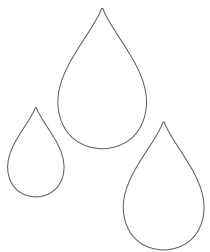

### Super Dave's All Abilities Park

Design# 1158311-02-03 3/20/25

©2025 Aquatix by Landscape Structures. All Rights Reserved | [aquatix.playlsi.com](http://aquatix.playlsi.com)



## AGE APPROPRIATE ZONES

### GENTLE ACTIVITY ZONE INFANT/TODDLER

#### Learning to enjoy texture and water

- Lower, delicate ground sprays
- Lower structures with gentle water formations
- Placement of features close to perimeter and dry zones ensure easy adult supervision and interaction

### UNIVERSAL ZONE ALL AGES

#### Variety of structures for the whole family

- Unique water formations pour, dump, spray wiggle, launch and spin
- Combines ground spray and structures for all ages
- Centrally placed in splash pad and often a transition zone from Gentle activity to Dynamic

### DYNAMIC ZONE 7+ YEARS

#### Continual excitement and interaction

- High Volume, highly interactive spray features and Climb 'N Play structures
- Combination of sprays and structures
- Placement of features close to perimeter and dry zones ensure easy adult supervision and interaction

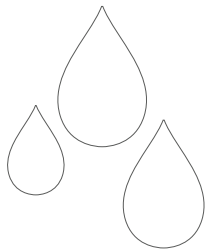
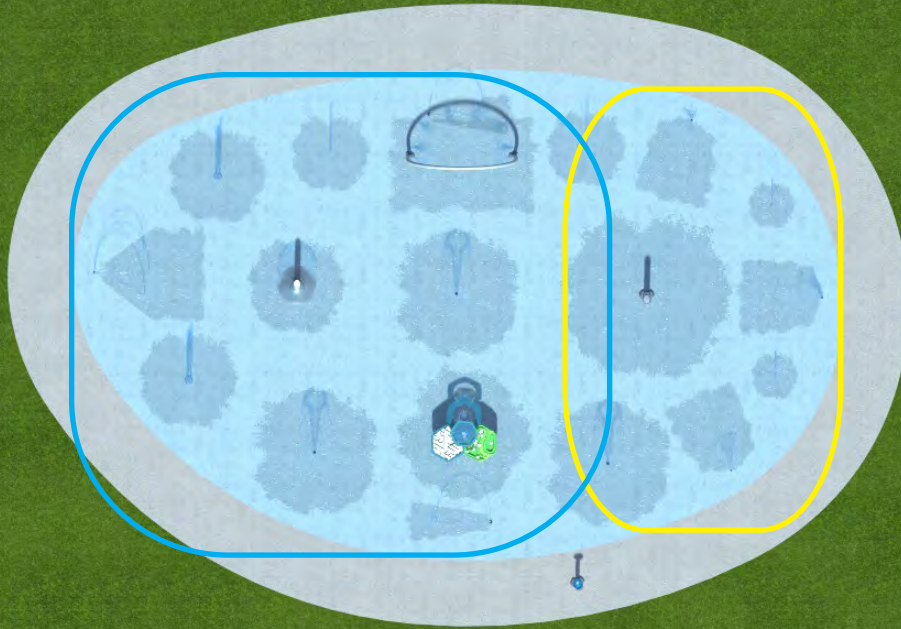

## Super Dave's All Abilities Park

Design# 1158311-02-03 3/20/25

# DESIGN DETAILS

\*Surface finishes and/or site furnishings shown are conceptual and provided by others.



**PROUDLY PRESENTED BY**

Vanessa Zelaya  
 Lone Star Recreation Of Texas  
 vanessa.zelaya@lonestarrecreation.com  
 (281) 970-9010

**Super Dave's All Abilities Park**

Design# 1158311-02-03 3/20/25



## PROPOSED COLORS

### PAINT COLORS



### ACRYLIC COLOR(S)



## PROJECT DETAILS

### PROJECT DIMENSIONS

82' 1"  $\times$  56' 9"  
LENGTH WIDTH

### TOTAL SYSTEM FLOW RATE

154 Gallons  
GPM (GALLONS PER MINUTE)

## COLOR APPROVAL

CUSTOMER SIGNATURE

DATE

\*Colors shown are for representation purposes.  
 Consult with your Representative for actual color swatches for final color selection.



- NOTE:
- ALL CONCRETE SLOPES TO BE 1/8"/FT MIN. AND 1/4"/FT MAX.
  - SITE ELEVATIONS OF SPLASH PAD AND CONCRETE APRON TO BE VERIFIED BY OTHERS. AQUATIX ELEVATION REFERENCE IS 0'-0" FOR TOP OF DRAIN BOX. ALL OTHER NOTED ELEVATIONS ARE REFERENCED FROM THAT POINT. REFER TO SPEC SHEET AND INSTALLATION DRAWING FOR EACH PRODUCT.
  - ACTUAL SIZE, SHAPE, AND LOCATION OF SPLASH PAD TO BE FIELD DETERMINED BY OTHERS. ALL DIMENSIONS OF SIZE AND SHAPE OF SPLASH PAD FOR REFERENCE ONLY.
  - THE INTENT OF A SPLASH PAD IS TO BE A DRY DECK WITH NO STANDING WATER. THE WATER IS TO BE CONTAINED WITHIN THE PERIMETER OF THE SPLASH PAD AND ALL WATER IS TO DRAIN INTO THE DRAIN BOXES. THE CONCRETE IS TO BE FORMED AND SLOPED TO ACCOMMODATE THIS DRAIN PATTERN.
  - ALL TREATED SPLASH PAD WATER IS INTENDED TO REMAIN WITHIN DESIGNATED SPLASH PAD DECK. UNDER NO CIRCUMSTANCES SHOULD SLOPE OF SPLASH PAD ALLOW WATER TO DRAIN OFF PAD.
  - UNDER NO CIRCUMSTANCES SHALL THE SURROUNDING HARDSCAPE AREA BE SLOPED TO ALLOW WATER TO BE DRAINED INTO THE SPLASH PAD DECK.
  - ALL CONCRETE SURFACES TO HAVE A MEDIUM BROOM FINISH.
  - EXPANSION JOINT TO BE EVERY 20'x20'. SAW CUT JOINT TO BE EVERY 10'x10'. COORDINATE EXPANSION JOINT AND SAW CUT LOCATIONS WITH PLAY EQUIPMENT LOCATIONS.
  - DRAWINGS ARE FOR DESIGN/LAYOUT PURPOSES ONLY. PLEASE SEE AQUATIX BY LANDSCAPE STRUCTURES FOR INCLUDED STRUCTURES, EQUIPMENT, SERVICES, AND EXCLUSIONS.
  - INDICATES SPLASH ZONE.
  - SPLASH ZONES ARE APPROXIMATE. ACTUAL SPLASH ZONE MAY VARY BASED ON VARIOUS ENVIRONMENTAL CONDITIONS, FLOW RATES, SLOPE OF THE SPLASH PAD, SUBMERGENCE DEPTH AND WIND. DRAWINGS ARE SCHEMATIC ONLY.
  - 18" OF GRANULAR FILL RECOMMENDED, OR AS SOIL CONDITIONS AND/OR LOCAL CODE REQUIRES WITH A MINIMUM OF 2500 PSF SOIL BEARING CAPACITY THERE IS TO BE A MINIMUM OF 6" OF GRANULAR FILL AROUND ALL PIPING.
  - CONCRETE REINFORCEMENT TO BE #4 REBAR @ 12" O.C. EACH WAY OR EQUIVALENT WELDED WIRE MESH (W6 ON 4"X4" SPACING OR W10 ON 6"X6" SPACING)
  - CONCRETE TO BE THICKENED AT ALL PRODUCT INSTALLATION LOCATIONS (BOTH EMBED AND ABOVE GROUND STRUCTURES). REFER TO INSTALLATION DRAWINGS FOR EACH PRODUCT.
  - SCHEDULE 80 PVC TO BE UTILIZED FOR ALL SPLASH PAD MECHANICAL SYSTEM PIPING.
  - LEVEL MOUNTING AREA REQUIRED FOR ALL PRODUCTS. RECOMMENDED POOL WATER DEPTHS:  
-DO NOT EXCEED 6" WATER DEPTH ON GROUND SPRAYS AND STRUCTURES UP TO 24" TALL  
-DO NOT EXCEED 12" WATER DEPTH ON STRUCTURES UP TO 48" TALL  
-DO NOT EXCEED 18" WATER DEPTH ON STRUCTURES TALLER THAN 48"  
-DO NOT EXCEED 12" WATER DEPTH ON MULTI LEVEL PLATFORMS. NO WATER SPRAY OR CRAWL TUNNEL TO BE UNDERWATER.
  - THICKENED AND LEVEL SLABS REQUIRED UNDER ENTIRE MULTI LEVEL STRUCTURES.

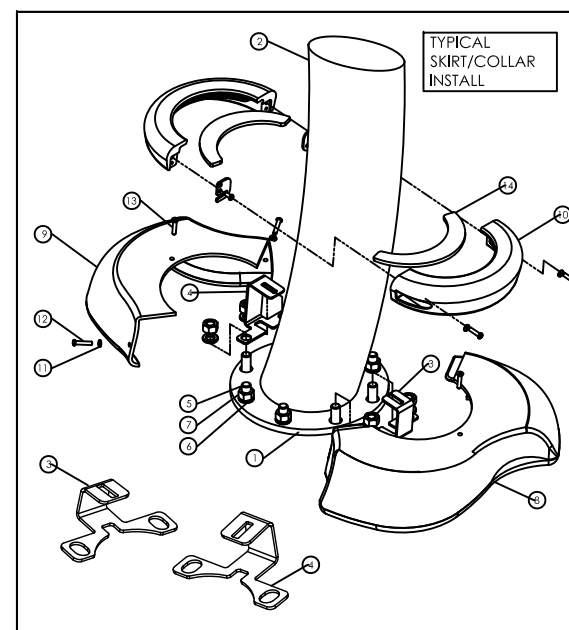
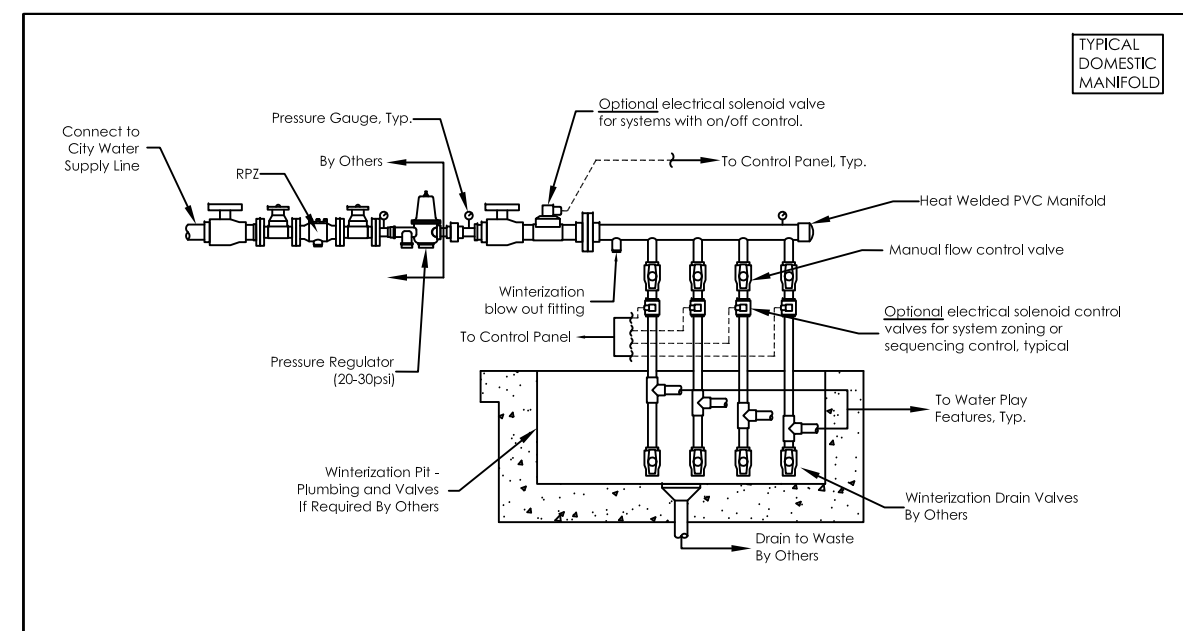
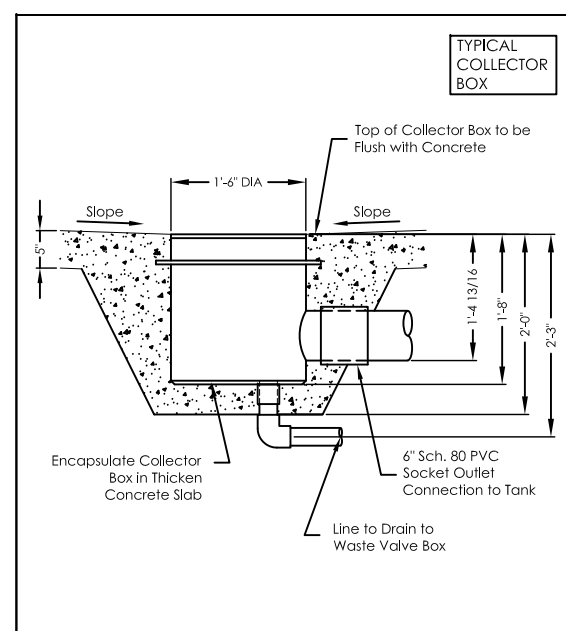
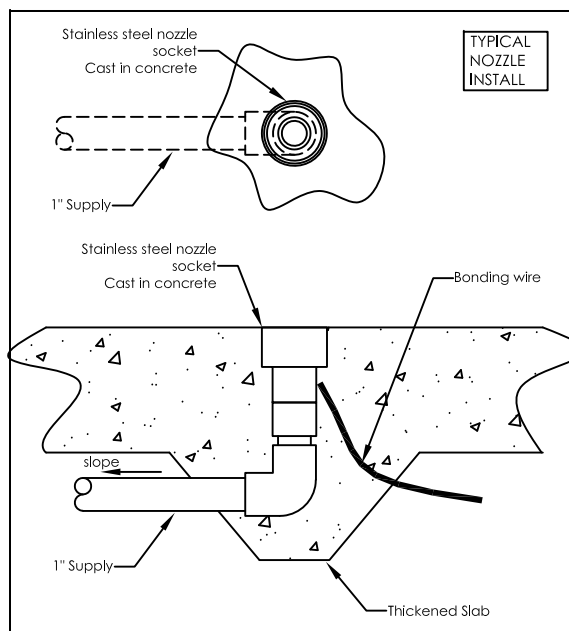
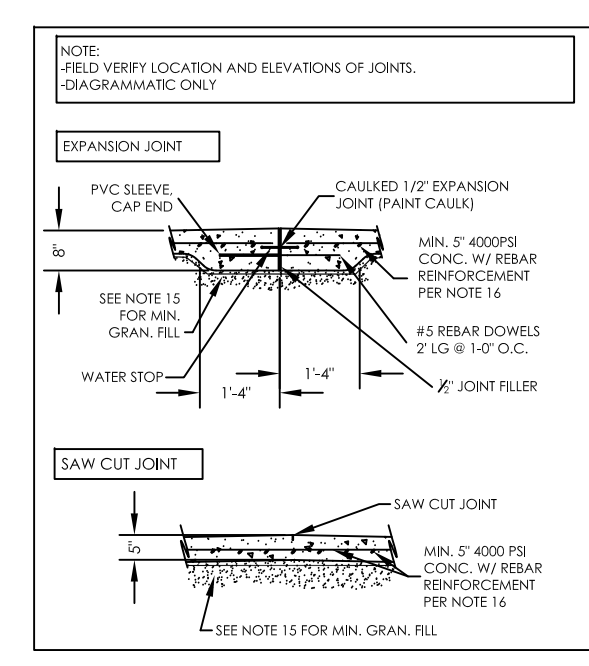
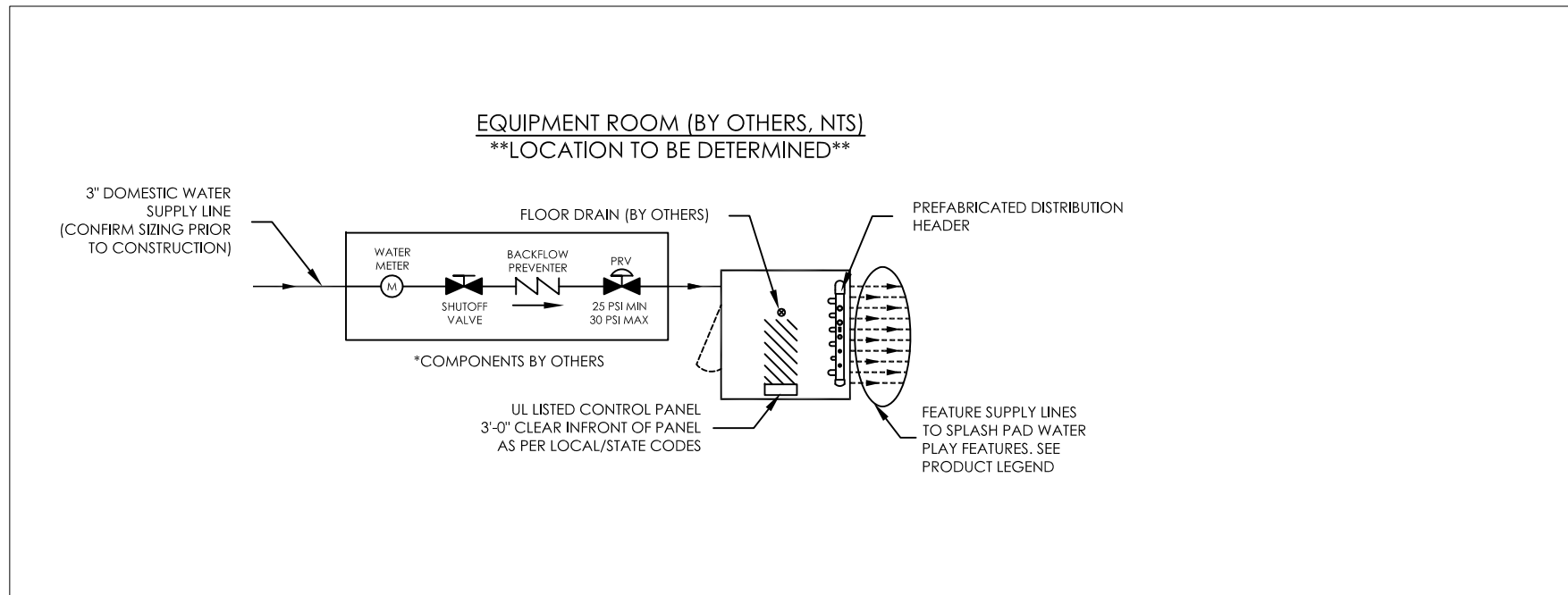

#### TYPICAL SKIRT/COLLAR INSTALL

ITEM NO.	PART NUMBER	DESCRIPTION	QTY.
1	6I GASKET	6I FLANGE GASKET	1
2	6I SCH 40-20 DEGREE ASM.SLDPRT	TYPICAL TUBE	1
3	AQ400377	6I SKIRT LOW SIDE BRACKET	1
4	AQ400376	6I SKIRT HIGH SIDE BRACKET	1
5	625 ANCHOR BOLT	5/8" SST ANCHOR BOLT	8
6	625 LOCK WASHER	5/8" LOCK WASHER	8
7	100323	5/8-11 HEX NUT SST	8
8	AQ400283	6I SHIRT LOW SIDE	1
9	AQ400284	6I SHIRT HIGH SIDE	1
10	6I SKIRT ASM	COLLAR ASSEMBLY	1
11	90295A440	1/4" NYLON WASHER	2
12	BS04C0040SSH200	1/4-20 X 1 1/4 L SST SECURITY HEX PAN HEAD	2
13	FS04C0040SSH200	1/4-20 X 1 1/4 L SST SECURITY FLAT HEAD	2

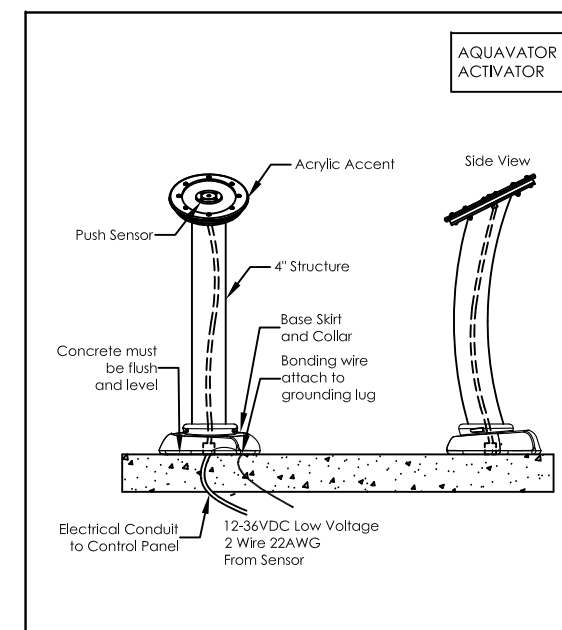

NOT FOR CONSTRUCTION

DATE		JOB TITLE		DATE		JOB NO.	
NO.	REVISION	JOB TITLE	DATE	JOB NO.	DATE	JOB NO.	DATE
		SUPER DAVES ALL ABILITIES PARK	3/20/25	1158311-02-03	1158311-02-03	1158311-02-03	1158311-02-03
		SPLASH PAD	SHEET TITLE	PROPOSED SPLASH PAD	SCHEMATIC LAYOUT	1158311-02-03	1158311-02-03
		LOCATION	FULSHEAR, TX	2	OF 2	2	OF 2

1101 McKinley Pkwy  
Delano, MN 55328  
888-438-6574  
763-975-5900  
aquatix@playfix.com

aquatix

by landscape structures



**Lone Star Recreation of Texas, LLC.**

10701 Corporate Drive Suite 390  
 Stafford, TX 77477  
 Phone: 281-970-9010

**PROPOSAL**

Quote # **11209-06**

Page 1 of 4

**Contact:** Tyler Kendziora  
**Company:** Fort Bend County  
**Phone:** 346-481-6938  
**Email:** Tyler.Kendziora@fortbendcountytexas.gov

**Ship To:** Landscape Structures, Inc.  
 Aquatix Certified Installer

**Bill To:** Fort Bend County  
 301 Jackson St, Suite 201  
 Richmond, TX 77469

**Installation Site:** Super Dave's All Abilities Park - FAAP  
 Fulshear, TX

**Design Number:** 1158311-02-03

**Date:** 8/20/2025  
**Proposal Expires:** 9/30/2025

**Terms**  
 INCO Terms: F.O.B. Manufacturing Plant  
 Estimated Mfg. Lead Time: 12-14 weeks ARO  
 LSRT Payment Terms:  
**Equipment:** Ref. Schedule of Payments  
**Installation:** Ref. Schedule of Payments  
**Surface:** Ref. Schedule of Payments

**Proposal Prepared By**  
 Contact: Sarah Campise  
 Phone: 281-970-9010  
 Email: sarah.campise@LonestarRecreation.com

**Sales**  
 Contact: Vanessa Zelaya  
 Phone: 281-970-9010  
 Email: vanessa.zelaya@LonestarRecreation.com

**We are pleased to submit this proposal to supply the following items:**

QTY	ITEM NO.	DESCRIPTION	UNIT PRICE	EXTENDED AMT
1	AQ100767	AquaGather		
1	AQ100861	RippleRun Medium Rung- SS		
1	AQ101106	SprayShroud		
1	AQ100852	WellSpring		
2	AQ100834	Arch Jet - SS		
3	AQ101167	Crown Jet- SS	\$ 58,891.00	\$ 58,891.00
3	AQ101165	Jr. Water jewel - SS		
2	AQ101164	Mini Pillar- SS		
2	AQ101160	Sea Crawler- SS		
2	AQ101159	Stream Jet - SS		
1	AQ101158	Triple Arch Jet - SS		
		<b>Mechanical Components: Domestic Water System</b>	\$ 57,163.00	\$ 57,163.00
1		<i>Aquavator</i> - To consist of an stainless steel activation bollard with bulldog touch sensor that will signal a control panel to activate feature supply system for set duration of time.		Included
1		<i>Control Panel (Sequencing)</i> - To be a UL listed control panel with integrated color touchscreen that will provide complete operating system power and controls. Programmable features allow customization of hours of operation, feature sequencing, and activate water flow via a touch enabled activation device. System is also internet enabled to allow remote access (requires network connection, by others). Typical electrical requirements or sequencing domestic systems are 120v 1/Ph 60htz		Included
1		<i>Rain Diverting Waste Box</i> - To consist of an electric gate valve housed in a plastic burial housing that will allow for collector boxes to drain to waste when feature pumping system is not operating.		Included

SUBTOTAL \$ 116,054.00

Pricing is for the above listed equipment only: NO installation, subgrade, drainage, additional contract terms, additions or deletion, change orders, insured addendum, off loading of equipment, storage of product, site security, retainage, or any applicable taxes, bonds, permits or freight are included unless listed as separate line items. Freight charges will be included with initial invoice.

Tax Exemption Certificate must be supplied with order if applicable

Change orders, cancellation, and/or rescheduling of services will be subject to available schedule and payment for incurred time & expenses, freight and fees.

LSRT reserves the right to apply payments to past due invoices first before applying payments to specific orders.

1.5% per month late payment fee will be applied for late payments

LSRT Terms and Conditions apply unless Subcontract is on file.



## Lone Star Recreation of Texas, LLC.

10701 Corporate Drive Suite 390  
Stafford, TX 77477

Phone: 281-970-9010

## PROPOSAL

Quote # **11209-06**

Page 2 of 4

**Contact:** Tyler Kendziora  
**Company:** Fort Bend County  
**Phone:** 346-481-6938  
**Email:** Tyler.Kendziora@fortbendcountytexas.gov

**Ship To:** Landscape Structures, Inc.  
Aquatix Certified Installer

**Bill To:** Fort Bend County  
301 Jackson St, Suite 201  
Richmond, TX 77469

**Installation Site:** Super Dave's All Abilities Park - FAAP  
Fulshear, TX

**Design Number:** 1158311-02-03

**Date:** 8/20/2025  
**Proposal Expires:** 9/30/2025

**Terms**  
INCO Terms: F.O.B. Manufacturing Plant  
Estimated Mfg. Lead Time: 12-14 weeks ARO  
LSRT Payment Terms:  
**Equipment:** Ref. Schedule of Payments  
**Installation:** Ref. Schedule of Payments  
**Surface:** Ref. Schedule of Payments

**Proposal Prepared By**  
**Contact:** Sarah Campise  
**Phone:** 281-970-9010  
**Email:** sarah.campise@LonestarRecreation.com

**Sales**  
**Contact:** Vanessa Zelaya  
**Phone:** 281-970-9010  
**Email:** vanessa.zelaya@LonestarRecreation.com

We are pleased to submit this proposal to supply the following items:

QTY	ITEM NO.	DESCRIPTION	UNIT PRICE	EXTENDED AMT
1		<i>Distribution Manifold (Sequencing)</i> - To consist of a Sch. 80 PVC distribution manifold with electric solenoid valves for sequencing on / off of water play elements and manual valves for adjusting water flows to water play elements. Solenoids and valves provided for field installation.		Included
1		<p><b>Design Services</b> All design and construction drawings for splash pad project construction including construction of concrete pad, mechanical system, electrical and control systems, inbed spray fixtures / collector box installation details, water play structure assembly / installation on concrete splash pad, equipment systems installation and hookups. Drawings to be stamped sealed by Texas PE.</p> <p>Splash Pad Design Notes: 1. Aquatix by Landscape Structures design services do not include soil corrections, demolition planning, site elevation plans, utility planning / design or relocation of utilities. (i.e. based on water, waste and power being available at designed area's of splash pad by others.) 2. All permits and costs of permits are not included. 3. Design package will be prepared based on Aquatix's interpretation of Local health code. 4. Pricing <b>does</b> include sealed Engineer Stamp.</p>		Included

SUBTOTAL \$ -

Pricing is for the above listed equipment only: *NO* installation, subgrade, drainage, additional contract terms, additions or deletion, change orders, insured addendum, off loading of equipment, storage of product, site security, retainage, or any applicable taxes, bonds, permits or freight are included unless listed as separate line items. Freight charges will be included with initial invoice.

Tax Exemption Certificate must be supplied with order if applicable

Change orders, cancellation, and/or rescheduling of services will be subject to available schedule and payment for incurred time & expenses, freight and fees.

LSRT reserves the right to apply payments to past due invoices first before applying payments to specific orders.

1.5% per month late payment fee will be applied for late payments

LSRT Terms and Conditions apply unless Subcontract is on file.



**Lone Star Recreation of Texas, LLC.**

10701 Corporate Drive Suite 390  
 Stafford, TX 77477  
 Phone: 281-970-9010

**PROPOSAL**

**Quote # 11209-06**

Page 3 of 4

**Contact:** Tyler Kendziora  
**Company:** Fort Bend County  
**Phone:** 346-481-6938  
**Email:** Tyler.Kendziora@fortbendcountytexas.gov

**Ship To:** Landscape Structures, Inc.  
 Aquatix Certified Installer

**Bill To:** Fort Bend County  
 301 Jackson St, Suite 201  
 Richmond, TX 77469

**Installation Site:** Super Dave's All Abilities Park - FAAP  
 Fulshear, TX

**Design Number:** 1158311-02-03

**Date:** 8/20/2025  
**Proposal Expires:** 9/30/2025

**Terms**  
 INCO Terms: F.O.B. Manufacturing Plant  
 Estimated Mfg. Lead Time: 12-14 weeks ARO  
 LSRT Payment Terms:  
**Equipment:** Ref. Schedule of Payments  
**Installation:** Ref. Schedule of Payments  
**Surface:** Ref. Schedule of Payments

**Proposal Prepared By**  
**Contact:** Sarah Campise  
**Phone:** 281-970-9010  
**Email:** sarah.campise@LonestarRecreation.com

**Sales**  
**Contact:** Vanessa Zelaya  
**Phone:** 281-970-9010  
**Email:** vanessa.zelaya@LonestarRecreation.com

**We are pleased to submit this proposal to supply the following items:**

QTY	ITEM NO.	DESCRIPTION	UNIT PRICE	EXTENDED AMT
1	INSTALLATION	Turnkey Construction and installation of Aquatix Splash Pad 1158311-02-01 by Manufacturer Trained Installer w/ 12 month labor warranty <ul style="list-style-type: none"> <li>Supply and Installation of MEP</li> <li><i>*Full installation of the Aquatix equipment package. We will also supply and install all interconnecting pipes, fittings, conduit, and wire - per drawings/specs. GC to bring a main water connection, and main power to the equipment space. It is estimated that the vault and equipment space will be located within 35' of the Splashpad</i></li> <li>Supply and Installation of Concrete</li> <li><i>*Included is the supply and installation of 3,736 sqft of standard grey concrete - along with the stone, rebar, forming, saw cutting, and a broom finishing of the concrete.</i></li> </ul> <p><b>Exclusions or Owner Responsibility:</b></p> <ul style="list-style-type: none"> <li>Connection of drains to storm sewer -main drain and mechanical enclosure drain</li> <li>Electrical power to enclosure</li> <li>Water supply to mechanical enclosure with Backflow Preventor, Pressure Regulator (20-30psig) and shut off valve</li> <li>Removal of excavated spoils if offsite</li> <li>Engineered control points and elevation bench mark within 30'</li> </ul>	\$ 258,976.00	\$ 258,976.00  Included
1	SURFACE	Supply and Installation of Non-Skid Spray Deck Flooring on 2,514 sqft of concrete in three standard colors	\$ 14,457.00	\$ 14,457.00

SUBTOTAL \$ 273,433.00

Pricing is for the above listed equipment only: NO installation, subgrade, drainage, additional contract terms, additions or deletion, change orders, insured addendum, off loading of equipment, storage of product, site security, retainage, or any applicable taxes, bonds, permits or freight are included unless listed as separate line items. Freight charges will be included with initial invoice.

Tax Exemption Certificate must be supplied with order if applicable

Change orders, cancellation, and/or rescheduling of services will be subject to available schedule and payment for incurred time & expenses, freight and fees.

LSRT reserves the right to apply payments to past due invoices first before applying payments to specific orders.

1.5% per month late payment fee will be applied for late payments

LSRT Terms and Conditions apply unless Subcontract is on file.



**Lone Star Recreation of Texas, LLC.**

10701 Corporate Drive Suite 390  
Stafford, TX 77477

Phone: 281-970-9010

**PROPOSAL**

Quote # **11209-06**

Page 4 of 4

**Contact:** Tyler Kendziora  
**Company:** Fort Bend County  
**Phone:** 346-481-6938  
**Email:** Tyler.Kendziora@fortbendcountytexas.gov

**Date:** 8/20/2025  
**Proposal Expires:** 9/19/2025

**Ship To:** Landscape Structures, Inc.  
Aquatix Certified Installer

**Terms**  
INCO Terms: F.O.B. Manufacturing Plant  
Estimated Mfg. Lead Time: 12-14 weeks ARO  
LSRT Payment Terms:  
**Equipment:** Ref. Schedule of Payments  
**Installation:** Ref. Schedule of Payments  
**Surface:** Ref. Schedule of Payments

**Bill To:** Fort Bend County  
301 Jackson St, Suite 201  
Richmond, TX 77469

**Proposal Prepared By**  
Contact: Sarah Campise  
Phone: 281-970-9010  
Email: sarah.campise@LonestarRecreation.com

**Installation Site:** Super Dave's All Abilities Park - FAAP  
Fulshear, TX

**Sales**  
Contact: Vanessa Zelaya  
Phone: 281-970-9010  
Email: vanessa.zelaya@LonestarRecreation.com

**Design Number:** 1158311-02-03

QTY	ITEM NO.	DESCRIPTION	% of PRICE	CONTRACT PRICE
1	EQUIPMENT	<b>Equipment Total</b> 30% Deposit 70% Net 30 from Shipment	\$ 34,816.20 \$ 81,237.80	\$ <b>116,054.00</b>
1	INSTALLATION	<b>Installation Total</b> 30% Mobilization Due 15 Days In Advance 70% Due Upon Completion of Project Net 15	\$ 77,692.80 \$ 181,283.20	\$ <b>258,976.00</b>
1	SURFACE	<b>Surface Total</b> 30% Mobilization Due 15 Days In Advance 70% Due Upon Completion of Project Net 15	\$ 4,337.10 \$ 10,119.90	\$ <b>14,457.00</b>
1	DISCOUNT	<b>BuyBoard Discount #679-22</b> 100% with Final Bill	\$ (19,474.30)	\$ <b>(19,474.30)</b>
1	FREIGHT	<b>Freight for Equipment</b> 100% with Order	\$ 5,884.00	\$ <b>5,884.00</b>
			<b>Subtotal</b>	\$ <b>375,896.70</b>
			<b>Sales Tax</b>	<b>Exempt</b>
			<b>Total</b>	\$ <b>375,896.70</b>

**By signing this proposal, the customer is agreeing to the scope of work and terms.**

Accepted by Customer \_\_\_\_\_ Date \_\_\_\_\_

Print Name \_\_\_\_\_ PO/Ref. # \_\_\_\_\_ Title \_\_\_\_\_

Pricing is for the above listed equipment only: NO installation, subgrade, drainage, additional contract terms, additions or deletion, change orders, insured addendum, off loading of equipment, storage of product, site security, retainage, or any applicable taxes, bonds, permits or freight are included unless listed as separate line items.

Individual line items invoiced according to Schedule of Payments. Freight charges will be included with initial invoice.

Tax Exemption Certificate must be supplied with order if applicable

Change orders, cancellation, and/or rescheduling of services will be subject to available schedule and payment for incurred time, expenses, freight, and/or fees.

LSRT reserves the right to apply payments to past due invoices first before applying payments to specific orders.

1.5% per month late payment fee will be applied for late payments

LSRT Terms and Conditions apply unless Subcontract is on file.



## ADDITIONAL TERMS AND CONDITIONS

**Entire Agreement:** This document, including the proposal and any referenced attachments in the proposal, if any, contains the entire agreement and understanding between the parties with respect to the transaction contemplated. This document sets forth all of the promises, agreements, conditions, and understandings between the parties respecting the subject matter hereof, and replaces and supersedes all negotiations, conversations, discussions, correspondence, memorandums, and oral agreements between the parties, as well as any prior writings. Except as set forth in this document, including any attached exhibits, if any, there are no other agreements, representations, warranties, or covenants by or among the parties hereto with respect to the subject matter hereof. This document, including any attached exhibits, if any, supersedes all other agreements, written or oral, between the parties with respect to the transaction contemplated.

**Modification:** No alteration, amendment, modification, or waiver of any provision of this Agreement shall be valid or effective unless it is in writing and signed by all parties. No oral agreement or course of conduct to the contrary, shall be deemed an alteration, amendment, modification, waiver, or cancellation. No evidence of any alteration, amendment, modification, or waiver shall be offered or received in evidence in any proceeding, mediation, or litigation between the parties hereto arising out of or affecting this Agreement, or the rights or obligations of the parties hereunder, unless such alteration, amendment, modification, or waiver is in writing, duly executed by both parties. Any waiver or consent shall be effective only in the specific instance and for the purpose for which it was given.

**Severability:** If any provision of this Agreement is determined to be invalid or not enforceable, or is prohibited by law for any reason, the invalidity shall not affect the validity of the remaining provisions of this Agreement. The rest of the Agreement will be unaffected.

**No Waiver of Rights:** No waiver by any party of any of its rights or remedies hereunder shall be considered a waiver of any other subsequent right or remedy of that party. The waiver by any party of a breach of any provision of this Agreement shall not be taken or held to be a waiver of the provision itself. Any course of performance shall not be deemed to amend or limit any provision of this Agreement. The failure of any party at any time to require performance by another party of any provision of this Agreement shall not affect in any way the full right to require the performance at any subsequent time. No delay or omission in the exercise of enforcement by either party of any rights or remedies shall ever be construed as a waiver of any right or remedy of that party. No exercise or enforcement of any rights or remedies shall ever be held to exhaust any right or remedy of any party. No action taken pursuant to this Agreement, including any investigation by or on behalf of any party, shall be deemed to constitute a waiver by the party taking such action of compliance with any representation, warranty, covenant, or agreement contained herein or therein and in any documents delivered in connection herewith or therewith. Forbearance or neglect on the part of either party to insist upon strict compliance with the terms of this Agreement shall not be construed as or constitute a waiver thereof.

**Relationship of Parties:** Nothing contained in this Agreement shall be deemed or construed by the parties, or by any third party, to create the relationship of employer/employee, partnership, or joint venture between the parties hereto, it being understood and agreed that no provision contained herein shall be deemed to create any relationship between the parties hereto other than as client and independent contractor.

**Compliance with Laws:** The parties hereto shall each comply with the provisions of all applicable federal, state, county, and local laws, ordinances, regulations, and codes.

**Collaborative Dispute Resolution:** The parties hereto shall cooperate with each other to affect the purpose and intent of this Agreement. If a dispute arises concerning this Agreement that cannot be resolved collaboratively, either with or without the assistance of collaborative counsel, the parties will try in good faith to settle the dispute through mediation conducted by a mediator to be mutually selected. The parties will share the cost of the mediator equally, but each party shall remain solely responsible for their own attorneys' fees and costs. The parties will cooperate fully with the mediator and will attempt to reach a mutually satisfactory resolution of the dispute. If the dispute is not resolved within thirty (30) days after it is referred to the mediator, the parties agree that the dispute can proceed to the courts of Harris County, Texas, governed by the laws of the State of Texas for Collaborative Law.

**Governing Law:** This Agreement, and the rights and obligations of the parties hereunder, is being executed and delivered, and is intended to be performed in the State of Texas. Except to the extent that the laws of the United States may apply to the terms hereof, the substantive laws of the State of Texas applicable to contracts made and to be performed wholly within Texas, without regard to any choice or conflict of laws rules, shall govern the validity, construction, enforcement, and interpretation of this Agreement. Any litigation arising from this Agreement will be brought in the courts of Harris County.

**Attorneys' Fees:** Excluding mediation, in the event that an action, litigation, or proceeding results from or arises out of this Agreement or the performance thereof, including any appeal or the collection of any judgment, the parties agree to reimburse the prevailing party's reasonable attorney's fees, court costs, and all other expenses, whether or not taxable by the court as costs, in addition to any other relief to which the prevailing party may be entitled, as allowable by law. A prevailing party is defined as a party who secures a judgment in its own favor through a legal process other than mediation.

**Successors and Assigns:** Except as specifically provided in this Agreement, no party may assign, delegate, or transfer any of its rights or obligations under this Agreement, in whole or in part, without the prior written consent of the other, which consent will not be unreasonably withheld. The terms hereof are contractual in nature and are not mere recitals, and the obligations created by this Agreement shall be binding upon the successors, legal representatives, and permitted assigns of the parties hereto, forever.

**Force Majeure:** Neither party shall be liable, nor held in breach of contract, for any loss, damage, and/or any delay in performance that may be suffered as a direct or indirect result of either party being prevented, hindered, or delayed in its performance by circumstances beyond that party's reasonable control due to force majeure, including among others, strikes; lock outs, accidents; trade or labor disputes; natural disasters, including explosions, fire, flood, storm, wind, or drought; war, terrorism, riots, civil commotion, government action, embargoes, and/or acts of civil or military authorities; shortages of transportation, facilities, fuel, energy, labor, or materials; acts of God (specifically including hurricanes and inclement weather that shuts down city services); or any delay or failure resulting from a cause or causes outside either party's reasonable control. If timely completion is prevented by any cause of force majeure, then such failure or delay shall not constitute default.

**Escalation:** During the performance of this agreement, if the price of materials, equipment or energy are significantly increased, through no fault of Lone Star Recreation of Texas, the price shall be equitably adjusted by an amount reasonably necessary to cover any such significant increases. As used herein, a significant price increase shall mean any increase exceeding 5% from the date of the contract signing. Such price escalations shall be documented through change order, quotes, invoices, and/or receipts in accordance with the agreed contract procedure. Where the delivery of material, equipment, or energy is delayed, through no fault of the contractor, as a result of the shortage or unavailability, contractor shall not be liable for any additional costs or damages associated with such delay(s).

**Gender and Numbers:** Unless the context clearly indicates, whenever used, the singular shall include the plural, the plural the singular, and the use of any gender shall include all genders.

**No Third-Party Rights:** This Agreement is solely for the benefit of the parties hereto and their respective successors and assigns, if any, and no other person or entity shall have any right, benefit, priority, or interest hereunder, or because of the existence of this Agreement.

**Headings:** The section headings contained in this Agreement are for convenience and reference purposes only and shall not affect the meaning, interpretation, or construction of this Agreement, and in no way define, describe, extend, or limit the scope or intent of this Agreement, or the intent of any provisions hereof.

**Voluntary Agreement & Advice of Counsel:** The parties confirm and agree that each (i) has relied on its own judgment and has not been induced to sign or execute this Agreement by promises, agreements, or representations not expressly stated herein, (ii) has freely and willingly executed this Agreement and hereby expressly disclaims reliance on any fact, promise, undertaking or representation made by any other party, save and except for the express agreements and representations contained in this Agreement, (iii) was not in a significantly disparate bargaining position with regard to any other party, and (iv) has been represented by legal counsel in this matter or has voluntarily waived that right.

**Multiple parts:** This Agreement may be executed by the parties hereto in any number of separate counterparts, each and all of which taken together shall be deemed for all purposes to be one agreement. It shall not be necessary in making proof of this Agreement to produce or account for more than one counterpart signed by the party to be charged.

**Electronic Signatures:** This Agreement may be executed by the parties hereto with electronic signatures, each of which shall be deemed for all purposes to be an original signature.

**Limited Liability:** Owner understands and agrees that LSRT's inspections, maintenance, or service calls shall not take the place of or release Owner from its duty or create any duty other than those expressly assumed herein. Owner is responsible for performing daily visual inspections and/or daily regular maintenance.

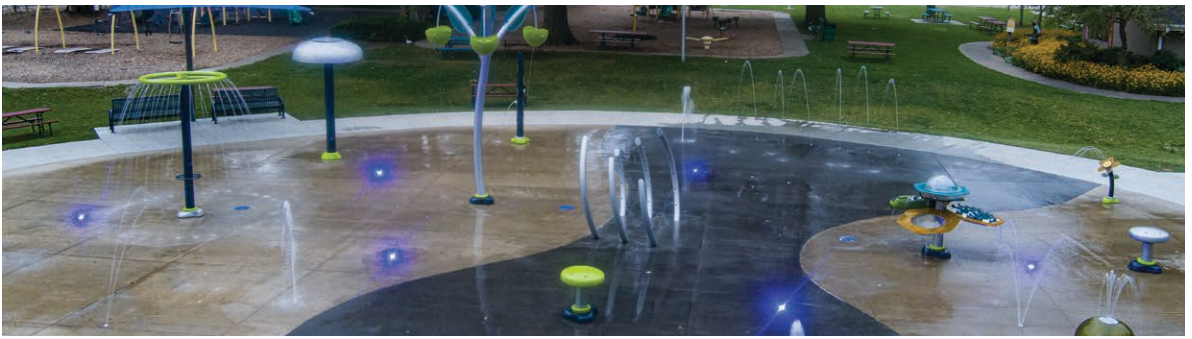

Aquatix® by Landscape Structures Inc. ("Manufacturer") warrants that all equipment sold will conform in kind and in quality to the specifications manual for the products identified in the Acknowledgment of Order and will be free of defects in manufacturing and material. Manufacturer further warrants:

**25-Year Limited Warranty** All stainless steel and fiberglass structures against defects in workmanship and materials.

**5-Year Limited Warranty** All brass and stainless steel components, including spray nozzles, spray caps and spray heads. Landing pad material against defects in workmanship and materials. Glass Fiber Reinforced Concrete (GFRC) structures or GFRC exterior defects—exclusion includes scale buildup, efflorescence, hairline cracks (defined by anything wider than a nickel in width) and spalling, flaking or wear and tear to paint coat due to traffic locations.

**3-Year Limited Warranty** All belting material

**2-Year Limited Warranty** All moving parts, finishes, hardware, polyurethane collars, acrylic and plastic panel attachments. HydroLogix® System components against defects in workmanship and materials. Does not cover any clouding of paint/clear coat due to improper chemicals, pool additives or pool cleaning products. High pressure power washing is NOT recommended on GFRC components.

**1-Year Limited Warranty** All mechanical system components against defects in workmanship and materials. Landing pad installation. All LED/Jumping Jet Can internal components and Accent Lights.

The environment near a saltwater coast can be extremely corrosive. Some corrosion and/or deterioration is considered "normal wear" in this environment. Product installed within 500 yards (457 meters) of a saltwater shoreline will only be covered for half the period of the standard product warranty, up to a maximum of five years, for defects caused by corrosion. Products installed in direct contact with saltwater or that are subjected to salt spray are not covered by the standard warranty for any defects caused by corrosion.

This warranty does not include any cosmetic issues or wear and tear from normal use of the product, or misuse or abuse of the product. It is valid only if the product is erected to conform with Aquatix' installation instructions and maintained according to the maintenance procedures furnished by Aquatix by Landscape Structures Inc.



## 2025 Aquatix® Product Warranty

You have our word.

More than just a contract, our warranty is our personal commitment that you'll be satisfied with your purchase now and well into the future. As an employee-owned company, we take great pride in the quality of everything we make. And we're so confident that you'll be delighted with your purchase that we back our products with the most comprehensive long-term warranty in the industry. It's just one more way that we show how much we care about our customers and communities.

All the warranties commence on date of Manufacturer's invoice. Should any failure to conform to the above express warranties appear within the applicable warranty period, Manufacturer shall, upon being notified in writing promptly after discovery of the defect and within the applicable warranty period, correct such nonconformity either by repairing any defective part or parts, or by making available a replacement part within 60 days of written notification. Manufacturer shall deliver the repaired or replacement part or parts to the site free of charge, but will not be responsible for providing labor or the cost of labor for the removal of the defective part or parts, the installation of any replacement part or parts or for disposal costs of any part or parts. Replacement parts will be warranted for the balance of the original warranty.

THIS WARRANTY IS EXCLUSIVE AND IN LIEU OF ALL OTHER WARRANTIES, WHETHER EXPRESSED OR IMPLIED, INCLUDING BUT NOT LIMITED TO ANY WARRANTY OF MERCHANTABILITY OR OF FITNESS FOR A PARTICULAR PURPOSE.

ANY SURETY BONDS ISSUED PURSUANT TO ANY CONTRACT OR SELLER'S INVOICE SHALL NOT INCLUDE COVERAGE FOR THIS GUARANTEE OR WARRANTY BEYOND ONE YEAR.

The remedies hereby provided shall be the exclusive and sole remedies of the purchaser. Manufacturer shall not be liable for any direct, indirect, special, incidental or consequential damages.

Manufacturer neither assumes nor authorizes any employee, representative or any other person to assume for Manufacturer any other liability in connection with the sale or use of the structures sold, and there are no oral agreements or warranties collateral to or affecting this agreement. The warranties stated above are valid only if the structures and/or equipment are erected in conformance with Aquatix by Landscape Structures' installation instructions and maintained according to the maintenance procedures furnished by Aquatix by Landscape Structures Inc.; have been subjected to normal use for the purpose for which the goods were designed; have not been exposed to saltwater or salt spray; have not been subject to misuse, negligence, vandalism, or accident; have not been subjected to addition or substitution of parts; and have not been modified, altered, or repaired by persons other than Manufacturer or Manufacturer's designees in any respect which, in the judgement of Manufacturer, affects the condition or operation of the structures.

To make a claim, send your written statement of claim, along with the original job number or invoice number to: Aquatix by Landscape Structures Inc. 1101 McKinley Parkway, Delano, Minnesota, 55328-8605.

Signed:  President Date: 01/01/2025

# CERTIFICATE OF INTERESTED PARTIES

FORM 1295

1 of 1

Complete Nos. 1 - 4 and 6 if there are interested parties.  
Complete Nos. 1, 2, 3, 5, and 6 if there are no interested parties.

**OFFICE USE ONLY  
CERTIFICATION OF FILING**

**Certificate Number:**  
2025-1366938

**Date Filed:**  
09/23/2025

**Date Acknowledged:**  
10/09/2025

**1 Name of business entity filing form, and the city, state and country of the business entity's place of business.**  
Lone Star Recreation of Texas, LLC  
Stafford, TX United States

**2 Name of governmental entity or state agency that is a party to the contract for which the form is being filed.**  
County of Fort Bend

**3 Provide the identification number used by the governmental entity or state agency to track or identify the contract, and provide a description of the services, goods, or other property to be provided under the contract.**  
101000  
All Abilities Play Equipment and Splash Pad - Proposal 11010-13

4	Name of Interested Party	City, State, Country (place of business)	Nature of interest (check applicable)	
			Controlling	Intermediary

**5 Check only if there is NO Interested Party.**

**6 UNSWORN DECLARATION**

My name is \_\_\_\_\_, and my date of birth is \_\_\_\_\_.

My address is \_\_\_\_\_, \_\_\_\_\_, \_\_\_\_\_, \_\_\_\_\_, \_\_\_\_\_.  
(city) (state) (zip code) (country)

I declare under penalty of perjury that the foregoing is true and correct.

Executed in \_\_\_\_\_ County, State of \_\_\_\_\_, on the \_\_\_\_\_ day of \_\_\_\_\_, 20\_\_\_\_.  
(month) (year)

\_\_\_\_\_  
Signature of authorized agent of contracting business entity  
(Declarant)