



Fort Bend County Engineering
FORT BEND COUNTY, TEXAS

J. Stacy Slawinski, P.E.
County Engineer

February 14, 2022

Judge KP George
Fort Bend County Judge
301 Jackson Street, Suite 719
Richmond, Texas 77406-0148

Re: Public Road Connection at FM 1464 for Trillium Bend Lane on behalf of TPHTM 1464, LLC. and FBC MUD 255 – Sponsorship

Honorable Judge George:

Fort Bend County Engineering Department has received and reviewed a request (letter attached) from Costello Inc. on behalf of TPHTM 1464, LLC., for Fort Bend County to sponsor a project for a public road connection for Trillium Bend Lane at FM 1464. The road connection will provide the primary point of access for the Trillium Development.

Any and all cost involved with the project will be borne by TPHTM 1464 LLC., and FBC MUD 255. There will be no cost to Fort Bend County.

The Texas Department of Transportation requests that an agency, such as Fort Bend County, act as a sponsor for the project. This means that the permit for the work will be issued in the name of Fort Bend County and the County accepts responsibility for the terms and conditions of the permit.

We recommend acceptance of the sponsorship and request that this item be placed on the 02/22/2022 Commissioners Court agenda. We have prepared a letter to Texas Department of Transportation for the County Judges' signature.

If there are any questions please do not hesitate to call.

Sincerely,

Maggie Dalton
Development Services Manager

Attachment: Scope of Work

cc: Commissioner Ken R. DeMerchant, Pct. 4
File



COUNTY JUDGE

Fort Bend County, Texas

The Honorable KP George
County Judge

(281) 341-8608
Fax (281) 341-8609

February 22, 2022

Ms. Eliza Paul, P.E.
District Engineer, Houston District
Texas Department of Transportation
7600 Washington Ave.
Houston, TX 77007-1044
Eliza.paul@txdot.gov

Re: Public Road Connection at FM 1464 for Trillium Bend Lane on behalf of TPHTM 1464, LLC. and FBC MUD 255 - Sponsorship

Dear Ms. Paul:

Fort Bend County has received and reviewed a request (letter attached) from Costello Inc. for Fort Bend County to sponsor a Texas Department of Transportation project on behalf of TPHTM LLC. and FBC MUD 255 for a public road connection for Trillium Bend Lane at FM 1464, at no cost to the County.

The request was approved by Fort Bend County Commissioners Court at their meeting dated 02/22/2022. We request that a permit for the public road connection be issued with Fort Bend County as sponsor for this project.

If there are any questions or need for additional information, please call Maggie Dalton in our Engineering Department at 281-633-7500.

Sincerely,

County Judge KP George

KP George
Fort Bend County Judge

KPG/
Attachments: Resolution
Drawing

cc: Mr. Jared Williams, Jones|Carter jwilliams@jonescarter.com
Ms. Denese Laskowski, TxDOT denese.laskowski@txdot.gov
File

THE STATE OF TEXAS §

COUNTY OF FORT BEND §

**RESOLUTION TO SPONSOR A PROJECT FOR A PUBLIC ROAD CONNECTION
FOR TRILLIUM BEND LANE AT FM 1464 ON BEHALF OF
TPHTM 1464 LLC., AND FBC MUD 255**

On this 22nd day of February, 2022, the Commissioners Court, sitting as the governing body of Fort Bend County, Texas, at a regular meeting, upon motion of Commissioner Meyers, seconded by Commissioner DeMerchant, duly put and carried;

WHEREAS, the proposed sponsorship project includes the installation of a public road connection at FM 1464 for Trillium Bend Lane.

WHEREAS, the funding for such sponsorship of the project is to be provided through sources other than Fort Bend County.

NOW, THEREFORE, BE IT RESOLVED that Fort Bend County expresses its support and sponsorship of such project with the Texas Department of Transportation to cause such improvements to be made at FM 1464 for Trillium Bend Lane.

FORT BEND COUNTY

By: 
County Judge KP George
KP George, County Judge

ATTEST:

Laura Richard, County Clerk

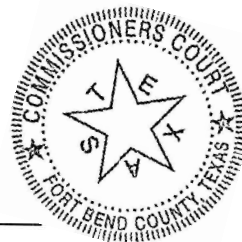



February 14, 2022 (Revised)

Honorable Judge KP George
Fort Bend County Judge
301 Jackson Street, Suite 719
Richmond, Texas 77469

Email: Maggie.Dalton@fortbendcountytexas.gov
Development@fortbendcountytexas.gov

Re: Fort Bend County Municipal Utility District No. 255
Request for Sponsorship Letter
Proposed Street Tie-In at FM 1464 for Trillium Development
Fort Bend County, Texas
C.I. Job No. 2021-006-TIA

Dear Honorable Judge KP George:

We respectfully request that Fort Bend County consider sponsoring the project referenced above. The Texas Department of Transportation ("TxDOT") will only consider a permit for the street tie-in of *Trillium Bend Lane* at FM 1464 if you agree to sponsor the work on behalf of Fort Bend County Municipal Utility District No. 255 (the "District"). This will provide the primary point of access for the Trillium development.

We are preparing the street connection permit application to submit to TxDOT for the proposed *Trillium Bend Lane* Street Tie-in to FM 1464. TPHTM 1464, LLC, the developer, will fund the cost of the construction. There will be no expense to Fort Bend County. The attached construction plan drawings were prepared in accordance with TxDOT's street tie-in permit requirements.

Please contact me if you need further information or have any questions.

Sincerely,
Costello, Inc.

A handwritten signature in blue ink that reads "Keith R. Billé".

Keith R. Billé, P.E.
Project Manager

W:\2021\2021006 Bono 438 Acre Tract\TXDOT Driveway Permit\Request for Sponsorship Letter_2-14-2022.docx

P:\TRILLIUM\2021006-601 TRILLIUM BEND LANE\EXHIBITS\TrilliumBendLn_FM1464 Exhibit.dgn
1/25/2022 2:58:21 PM

MATCHLINE

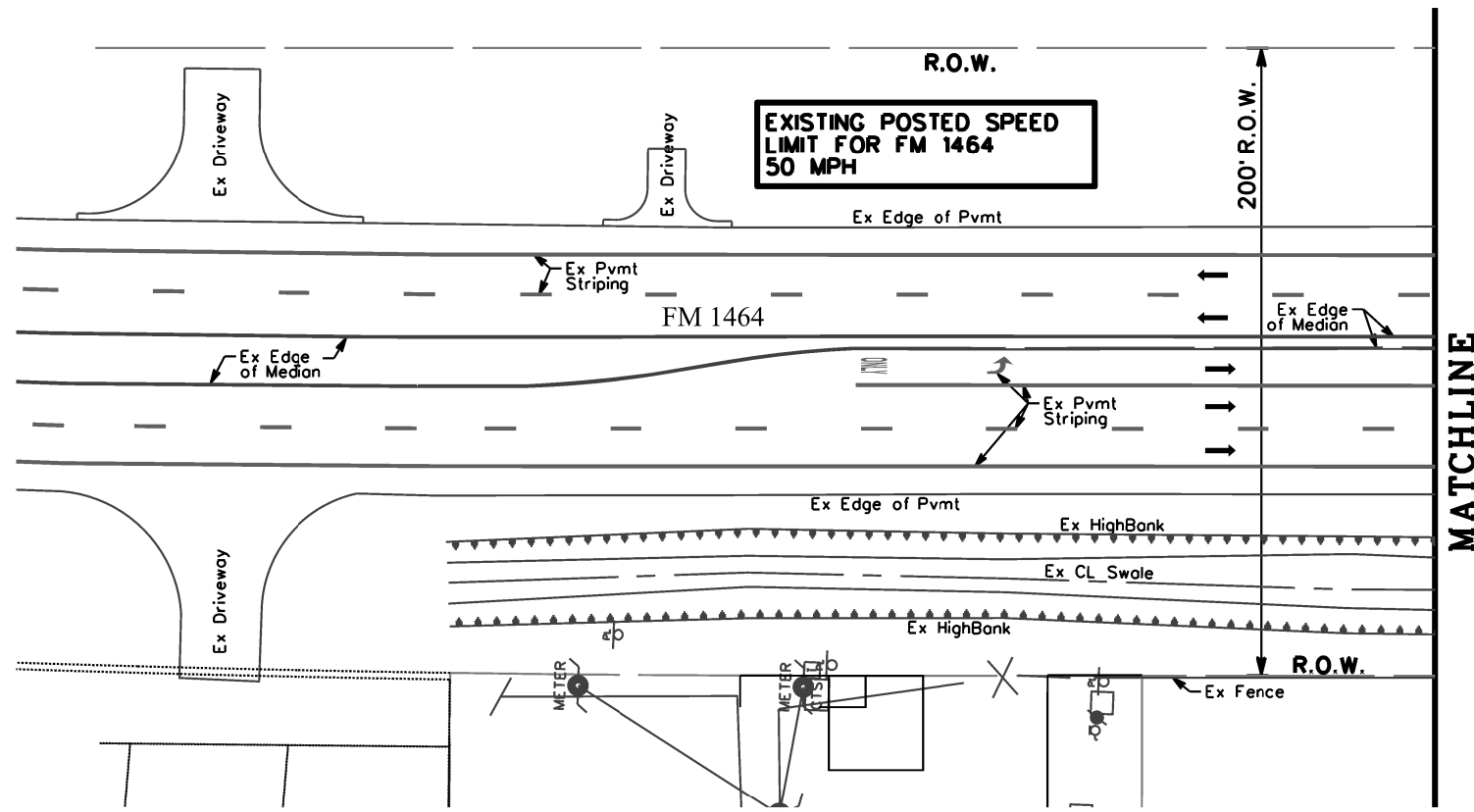
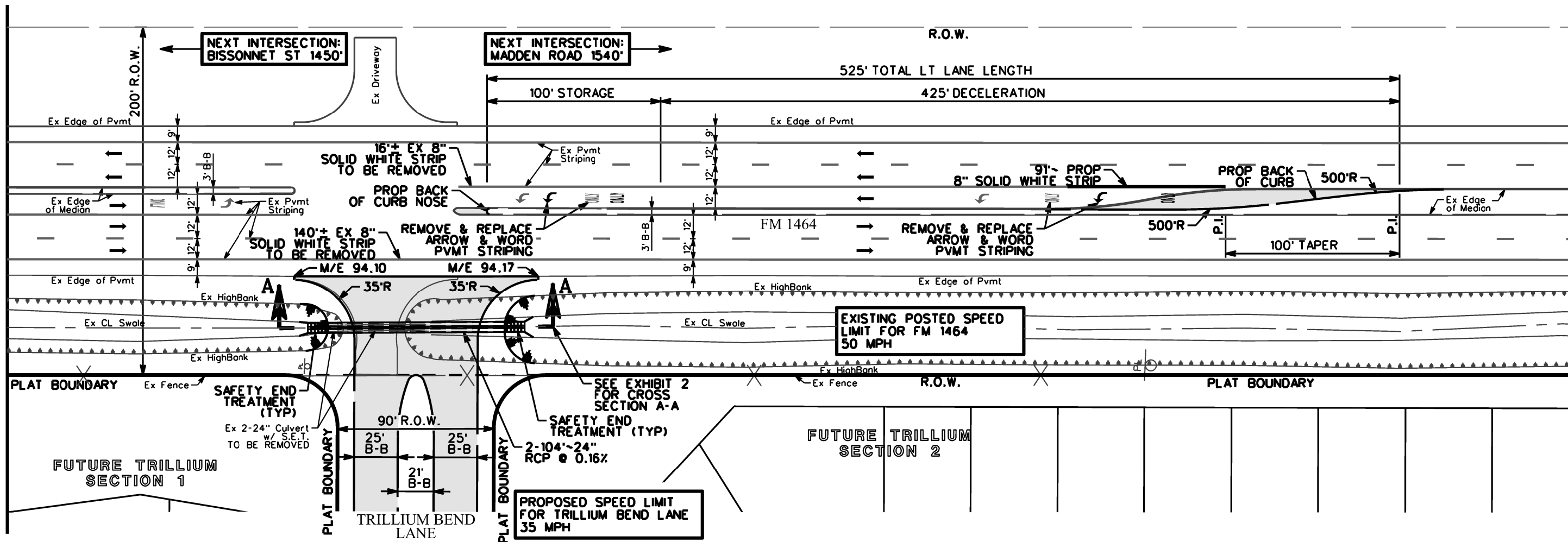

MATCHLINE

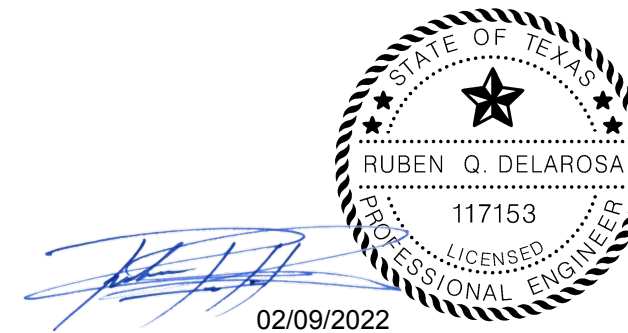

Engineering and Surveying
2107 CityWest Blvd., 3rd Floor
Houston, Texas 77042
(713) 783-7788 (713) 783-3580, Fax
TBPE FIRM REG. No. 280
TBPLS FIRM REG. No. 100486

TRILLIUM
EXHIBIT FOR PROPOSED
TRILLIUM BEND LANE / FM 1464
TIE-IN



JOB NO. : 2021006

DATE: 01/17/2022

EXHIBIT NO. : 1 OF 2

P:\TRILLIUM\2021006-601 TRILLIUM BEND LANE\EXHIBITS\TrilliumBend.n_fm1464 Profile Exhibit.dgn
1/25/2022 2:59:16 PM

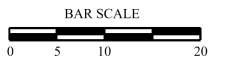
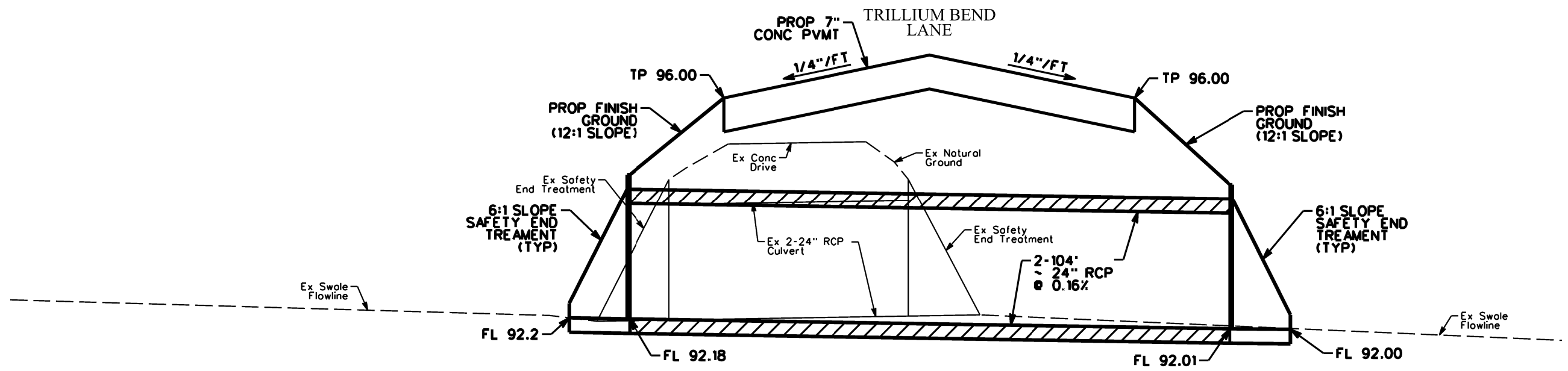

[Signature]
02/09/2022

STATE OF TEXAS
RUBEN Q. DELAROSA
117153
LICENSED PROFESSIONAL ENGINEER

	Engineering and Surveying 2107 CityWest Blvd., 3rd Floor Houston, Texas 77042 (713) 783-7788 (713) 783-3580, Fax	
	TBPE FIRM REG. No. 280 TBPLS FIRM REG. No. 100486	
TRILLIUM EXHIBIT FOR PROPOSED TRILLIUM BEND LANE / FM 1464 TIE-IN CROSS SECTION A-A		
JOB NO. : 2021006	DATE: 01/24/2022	EXHIBIT NO. : 2 OF 2

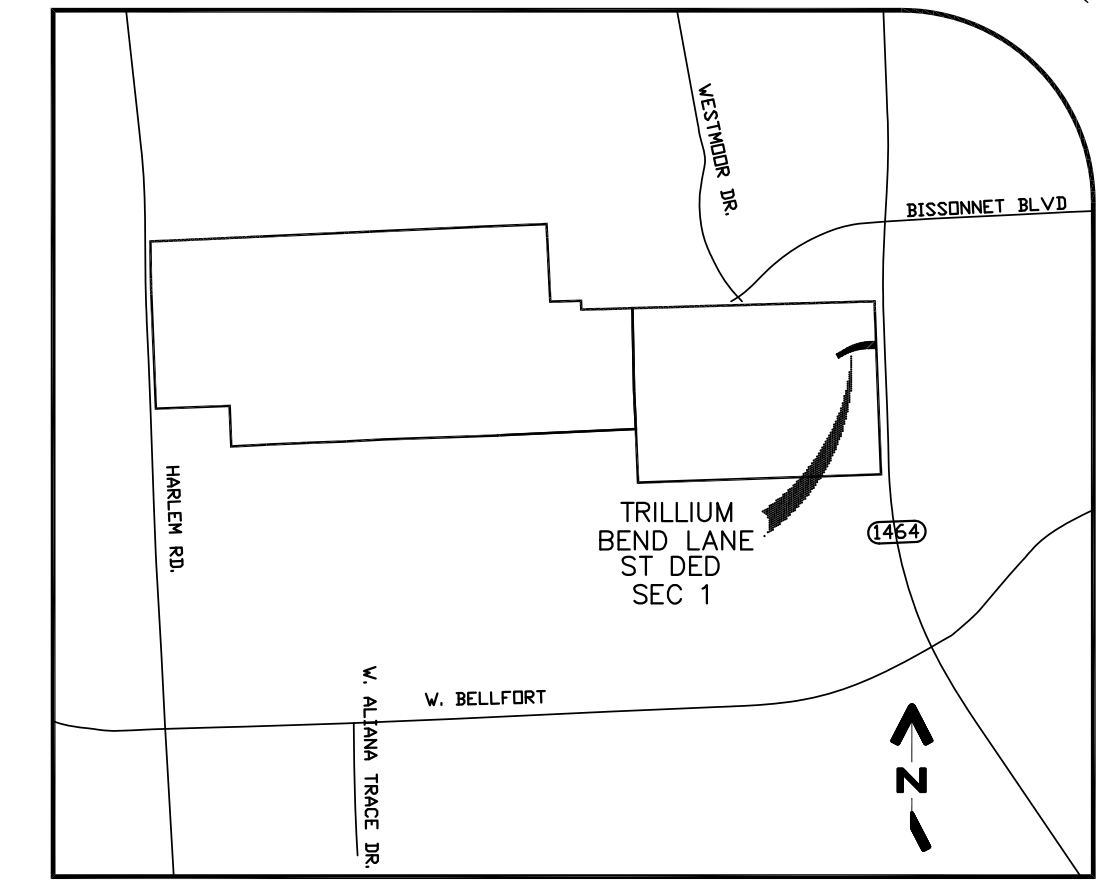

Vicinity Map

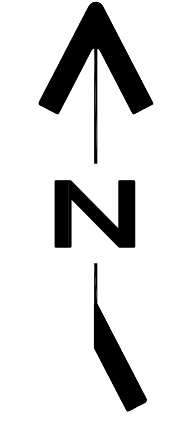

30' Permenet Easement
North Fort Bend Water Authority
C.F. No. 2012070924
O.P.R.F.B.C. (10P)

FM 1464
WIDTH VARIES
C.F. No. 2007087576
O.P.R.F.B.C.

Future
Development

Future
Development

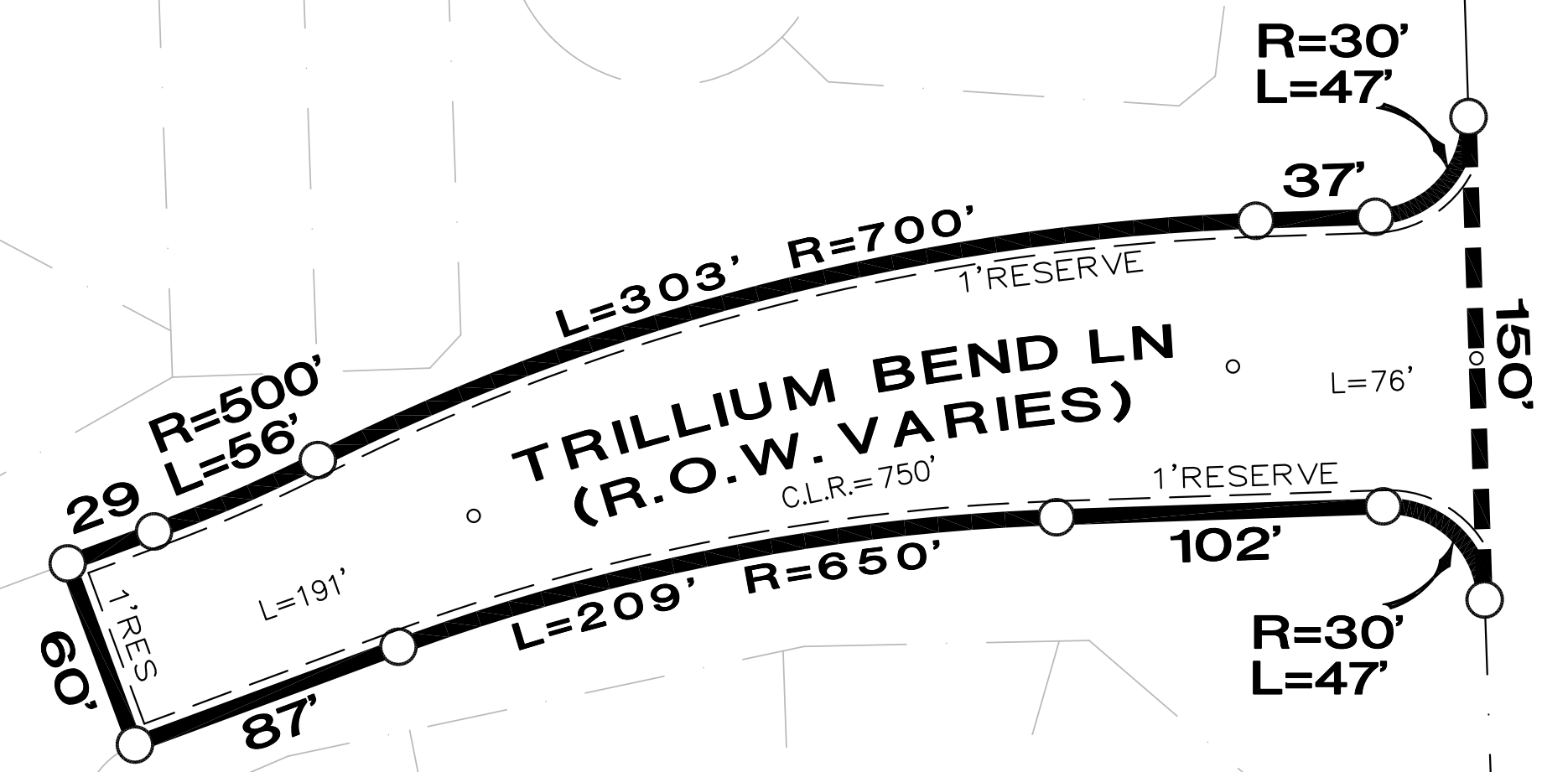

- GENERAL NOTE:
1. "1' RES." INDICATES ONE FOOT RESERVE.
dedicated to the public in fee as a buffer separation between the side or end of streets where such streets abut adjacent acreage tracts, the condition of such dedication being that when the adjacent property is subdivided in a recorded plat, the one foot reserve shall thereupon become vested in the public for street right-of-way purposes and the fee title thereto shall revert to and vest in the dedicatior, his heirs ossigns, or successors.
 2. ABSENT WRITTEN AUTHORIZATION BY THE AFFECTED UTILITIES, ALL UTILITY AND AERIAL EASEMENTS MUST BE KEPT UNOBSSTRUCTED FROM ANY NON-UTILITY IMPROVEMENTS OR OBSTRUCTIONS BY THE PROPERTY OWNER. ANY UNAUTHORIZED IMPROVEMENTS OR OBSTRUCTIONS MAY BE REMOVED BY ANY PUBLIC UTILITY AT THE PROPERTY OWNER'S EXPENSE. WHILE WOODEN POSTS AND paneled wooden fences along the perimeter and back to back easements and alongside rear lot lines ARE PERMITTED, THEY TOO MAY BE REMOVED BY PUBLIC UTILITIES AT THE PROPERTY OWNER'S EXPENSE SHOULD THEY BE AN OBSTRUCTION. PUBLIC UTILITIES MAY PUT SAID WOODEN POSTS AND paneled wooden fences back up, BUT GENERALLY WILL NOT REPLACE WITH NEW FENCING.
 3. THE COORDINATES SHOWN HEREON ARE TEXAS SOUTH CENTRAL ZONE NO.4204 STATE PLANE GRID COORDINATES (NAD83) AND MAY BE BROUGHT TO SURFACE BY APPLYING THE FOLLOWING COMBINED SCALE _____
 4. ALL PROPERTY LINE DIMENSIONS ARE APPROXIMATE.

A PRELIMINARY PLAT OF
TRILLIUM BEND LANE
STREET DEDICATION SEC 1
BEING 0.78± ACRES OF LAND

OUT OF THE
A.M. CLOPPER SURVEY, A-152
FORT BEND COUNTY, TEXAS

OWNER:
TPHTM 1464 LLC
PLANNER:



24275 KATY FREEWAY, SUITE 200
KATY, TEXAS 77494
Tel: 281-810-1422

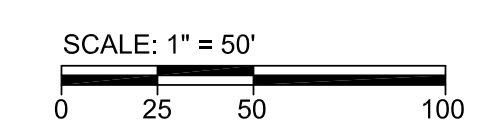

DECEMBER 06, 2021
MTA# 54003

DISCLAIMER AND LIMITED WARRANTY

THIS PRELIMINARY SUBDIVISION PLAT HAS BEEN PREPARED IN ACCORDANCE WITH THE PROVISIONS OF THE CITY OF HOUSTON ORDINANCE NO. 1998-262 IN EFFECT AT THE TIME THIS PLAT WAS PREPARED ALONG WITH ANY VARIANCE OR VARIANCES TO THE PROVISIONS OF THE AFOREMENTIONED ORDINANCE WHICH ARE SUBSEQUENTLY GRANTED BY THE CITY OF HOUSTON PLANNING COMMISSION. THIS PRELIMINARY PLAT WAS PREPARED FOR THE LIMITED PURPOSE OF GUIDANCE IN THE PREPARATION OF ACTUAL ENGINEERING AND DEVELOPMENT PLANS. THIS LIMITED WARRANTY IS MADE IN LIEU OF ALL OTHER WARRANTIES, EXPRESS OR IMPLIED, AND NEITHER META PLANNING + DESIGN LLC NOR ANY OF ITS OFFICERS, OR DIRECTORS, OR EMPLOYEES MAKE ANY OTHER WARRANTIES OR REPRESENTATIONS, EXPRESS OR IMPLIED CONCERNING THE DESIGN, LOCATION, QUALITY, CHARACTER OF ACTUAL UTILITIES OR OTHER FACILITIES IN, ON, OVER, OR UNDER THE PREMISES INDICATED IN THE PRELIMINARY SUBDIVISION PLAT.