

Fort Bend County Tabulation
BID 21-048
Term Contract for Purchase of Traffic Signs, Posts and Supplies

Term: April 1, 2021 through March 31, 2022

Recommendation: Lowest Bidder per Section

Vendor	Core Products LLC, Covington, LA	Custom Products Corporation, Jackson, MS	Dobie Supply, LLC., Austin, TX	Newman Signs Inc, Jamestown, ND	Osburn Associates Logan, OH	Trantex Transportation Products of Texas Inc., Houston, TX	Vulcan Signs, Foley, AL	Xcessories Squared Development & Mfg, Auburn, IL
Section 1: Complete Signs	No Bid	No Bid	\$ 13,480.00	\$ 12,500.00	No Bid	No Bid	\$ 13,467.00	No Bid
Section 2: Blanks	No Bid	No Bid	No Bid	\$217,036.25	\$224,579.30	No Bid	\$316,277.65	No Bid
Section 3: Posts & Accessories- Telespar Sign Support System	No Bid	No Bid	\$311,925.00	No Bid	No Bid	\$ 260,855.00	\$226,340.00	\$277,895.00
Section 4: Construction Supplies	No Bid	No Bid	\$229,630.00	No Bid	No Bid	\$ 236,800.00	No Bid	No Bid
Section 5: Carsonite Products	No Bid	No Bid	No Bid	No Bid	\$ 39,750.00	\$ 17,925.00	No Bid	No Bid
Section 6: 3M Products	No Bid	Disqualified: Did not bid all items in Section as required.	\$622,701.55	\$518,897.53	No Bid	No Bid	\$556,798.74	No Bid
Section 7: Avery Dennison Products	No Bid	No Bid	No Bid	No Bid	Disqualified: Did not bid all items in Section as required.	No Bid	\$320,491.34	No Bid
Section 8: Cutting Knives	No Bid	No Bid	No Bid	No Bid	\$ 11,525.00	No Bid	No Bid	No Bid
Section 9: Banding Materials	\$ 285.75	No Bid	No Bid	\$ 316.35	\$ 429.00	No Bid	No Bid	No Bid
Section 10: Safety Vests	No Bid	No Bid	\$ 9,240.00	No Bid	No Bid	\$ 10,290.00	No Bid	No Bid
Section 11: Stop/Slow Paddles	No Bid	No Bid	\$ 1,064.50	\$ 1,185.00	\$ 1,672.10	\$ 1,057.50	No Bid	No Bid
Section 12: Miscellaneous	No Bid	No Bid	\$ 95,150.00	No Bid	No Bid	\$ 70,415.00	No Bid	No Bid

**Fort Bend County Tabulation
 BID 21-048
 Term Contract for Traffic Signs, Posts and Supplies**

Term: April 1, 2021 through March 31, 2022

Recommendation: Lowest Bidder per Section

Section 1: Complete Signs Finished traffic signs must be .080 aluminum with faces, diamond grade, VIP, reflective sheeting. Add 3M protective overlay film (series 1160) to each sign.	Lawson Number	Newman Signs
		Bid Price per Each
All way, 18 x 6, red white VIP diamond Grade (MUTCD R1-4)	1794	\$ 5.00
Watch for ice on bridge, 36 x 36, hinged with closure hook, fluorescent yellow, diamond grade material	1795	\$ 85.00
Type III, 12x36, fluorescent yellow, DG3, (MUTCD OM-3R)	10400	\$ 20.00
Type III, 12x36, fluorescent yellow, DG3, (MUTCD OM-3L)	10401	\$ 20.00

Section 2: Blanks Blanks must be .080 aluminum	Lawson Number	Newman Signs
		Bid Price per Each
Blanks, rounded corners, diamond punch 18 x 18	1704	\$ 5.56
Blanks, rounded corners, diamond punch 24 x 24	1797	\$ 9.89
Blanks, rounded corners, diamond punch 30 x 30	1703	\$ 15.45
Blanks, rounded corners, diamond punch 36 x 36	1798	\$ 22.25
Blanks, octagon 30 x 30	1705	\$ 15.45
Blanks, octagon 36 x 36	10402	\$ 22.25
Blanks, pentagon 30 x 30	1799	\$ 15.45
Blanks, pentagon 36 x 36	1706	\$ 22.25
Blanks, rounded corners, rectangle 24 x 8	12539	\$ 3.30
Blanks, rounded corners, rectangle 24 x 10	12540	\$ 4.12
Blanks, rounded corners, rectangle 24 x 12	12541	\$ 4.94
Blanks, rounded corners, rectangle 12 x 18	1707	\$ 3.71
Blanks, rounded corners, rectangle 18 x 24	1709	\$ 7.42
Blanks, rounded corners, rectangle 24 x 30	1710	\$ 12.36
Blanks, rounded corners, rectangle 24 x 36	1803	\$ 14.83
Blanks, rounded corners, rectangle 30 x 36	1802	\$ 18.54
Blanks, rounded corners, rectangle 24 x 48	1711	\$ 19.78
Blanks, rounded corners, rectangle 30 x 48	1804	\$ 24.72
Blanks, rounded corners, rectangle 36 x 18	1800	\$ 11.12
Blanks, rounded corners, square 18 x 18	1712	\$ 5.56
Blanks, rounded corners, square 24 x 24	1805	\$ 9.89
Blanks, rounded corners, street sign, flat, 9 x 30	1713	\$ 4.63
Blanks, rounded corners, street sign, flat, 9 x 36	1714	\$ 5.56
Blanks, rounded corners, street sign, flat, 9 x 42	1715	\$ 6.49
Blanks, rounded corners, street sign, flat, 9 x 48	1716	\$ 7.42
Blanks, round, 36" diameter	1806	\$ 22.25
Blanks, rounded corners, rectangle, 10 x 30	1787	\$ 5.15
Blanks, rounded corners, rectangle, 12 x 30	1788	\$ 6.18
Blanks, rounded corners, triangle, 30	12542	\$ 7.72
Blanks, rounded corners, triangle, 36	14116	\$ 11.12
Blanks, extruded, 9 x 30	12543	\$ 7.46
Blanks, extruded, 9 x 36	12544	\$ 8.81
Blanks, extruded, 9 x 42	12545	\$ 10.15
Blanks, extruded, 9 x 48	12546	\$ 11.50
Blanks, extruded, 9 x 54	12547	\$ 13.50

Section 3: Posts and Accessories-Telespar Sign Support System	Lawson Number	Vulcan
		Bid Price per Each
12' Round 2.375 16 gauge galvanized post	14085	\$ 26.44
14' 1-3/4"x1-3/4" square 12 gauge galvanized sign post	14086	\$ 42.48
12" round post cap flat blade for 2.375" round post	14087	\$ 8.73
12" round post cap extruded for 2.375" round post	14088	\$ 8.73
74-5606 TRF RD RW 2.375 16 gauge Post, 12'	12548	\$ 26.44
75-4892 TRF RD Taper 2.875 Poz Loc Sockets	12549	\$ 19.38
76-6050 6603 RD Post Shim W/9/16" Hole Wedges	12550	\$ 3.50
Square sign post, 12 ft., 12 gauge, galvanized steel, pre-punched, 1-3/4" x 1-3/4"	8801	\$ 37.18
U channel galvanized steel post 7 ft. 1.12 lbs.	1752	\$ 8.91
Square post caps, 5-1/2" blade, flat with set screws	1753	\$ 3.37
Square post caps, 5-1/2" blade, extruded with set screws	1754	\$ 3.37
Round post caps for flat with set screws, 2-3/8" post OD for 5-1/2" blade	1790	\$ 3.37
Round post caps for extruded with set screws, 2-3/8" post	1791	\$ 3.37
Small corner bolts	1755	\$ 0.45
Flanged nuts	1756	\$ 0.10
Anchors: 1-7/8" x 1-7/8" x 36"	1757	
Drive Rivets, 3/8" aluminum	1758	\$ 0.45
Cross brackets for street signs, 5-1/2" blade holder with set screws for flat	1718	\$ 3.37
Cross brackets for street signs, 5-1/2" blade holder with set screws for extruded	1717	\$ 3.37
Cross brackets for street signs, 12" blade holder with set screws for flat	1792	\$ 8.72
Cross brackets for street signs, 12" blade holder with set screws for extruded	1793	\$ 8.72
2-7/8" OD, rounded, for flat blades, 5-1/2" blade holder with set screws	1807	\$ 3.37
2-3/8" OD, round 12" post caps for flat blade with set screws	7698	\$ 8.72
2-3/8" OD, round 12" post caps for extruded with set screws	7699	\$ 8.72
12" blade for flat street signs, square post cap, 1-3/4"	10403	\$ 8.72
12" blade for extruded street signs, square post cap, 1-3/4"	7700	\$ 8.72
2-3/8" post clamp with fasteners included with each clamp, aluminum	10404	\$ 1.97

Section 4: Construction Supplies	Lawson Number	Dobie Supply
		Bid Price per Each
Barricade, portable type I standard 36" plastic with reflective DG3 diamond grade sheeting with aluminum legs	1719	\$ 62.50
Barricade, Type III collapsible, diamond grade reflective sheeting, no-maintenance plastic boards, 8 foot, double sided sheeting right and left with Telespar tubing for upright support and legs, 1" thick x 8" tall board	1808	\$ 210.00
Barricade, Type III collapsible, diamond grade reflective sheeting, no-maintenance plastic boards, 10 foot, double sided sheeting right and left with Telespar tubing for upright support and legs, 1" thick x 8" tall board	1809	\$ 285.00
Barricade, Type III collapsible, diamond grade reflective sheeting, no-maintenance plastic boards, 12 foot, double sided sheeting right and left with Telespar tubing for upright support and legs, 1" thick x 8" tall board	1810	\$ 345.00
End of Road barricade boards, Type III with DG3 diamond grade sheeting on no-maintenance plastic boards, 10', red and white, 1" thick x 8" tall board, 3 right boards	9676	\$ 158.00
End of Road barricade boards, Type III with DG3 diamond grade sheeting on no-maintenance plastic boards, 10', red and white, 1" thick x 8" tall board, 3 left boards	11472	\$ 158.00
Barricade, two (2) "A" frames with two (2) 10' diamond grade sheeted I-beams, molded no-maintenance plastic boards, orange and white, right on one side and left on other side	11473	\$ 232.50
Safety cones, 28", orange, 12# weight, 4" upper reflective collars, with white diamond grade VIP reflective sheeting, 14-3/4" x 14-3/4" base	10405	\$ 24.00
Safety cones, 28", orange, 12# weight, 6" upper reflective collars, with white diamond grade VIP reflective sheeting, 14-3/4" x 14-3/4" base	10406	\$ 24.00
Safety cones, 36", orange, 12# weight, 4" upper reflective collars, with white diamond grade VIP reflective sheeting, 14-3/4" x 14-3/4" base	10407	\$ 25.00
Safety cones, 36", orange, 12# weight, 6" upper reflective collars, with white diamond grade VIP reflective sheeting, 14-3/4" x 14-3/4" base	10408	\$ 25.00

Section 4: Construction Supplies (cont'd)	Lawson Number	Dobie Supply
		Bid Price per each
Vertical Panel with 20" x 28" black rubber rectangular base, reflective panel 8" x 36", orange and white diagonal sheeting, double sided, diamond grade reflective sheeting,	1730	\$ 47.75
Warning light, Colt RS-600, 6 volt type A	1731	\$ 18.00
Warning light spring battery, general purpose 6 volt type A	1732	\$ 5.00
Delineator reflectors, 4" x 4", white aluminum with diamond grade sheeting	1812	\$ 2.24
Delineator reflectors, 4" x 4", fluorescent yellow aluminum with diamond grade sheeting	1733	\$ 2.24
Standard roll up construction signs, 48 x 48 reflective, vinyl, plastic corner pockets with ribs with overlays, fluorescent orange. All construction signs in the Texas Manual on Uniform Traffic Control with carrying bags	1782	\$ 152.50
Standard roll up construction signs, 36 x 36 reflective, vinyl, plastic corner pockets with ribs with overlays, fluorescent orange. All construction signs in the Texas Manual on Uniform Traffic Control with carrying bags	14089	\$ 124.00
DF3000W 12" Screwlock Roll-Up Sign Stand	14090	\$ 130.00
DF3003W 12" Screwlock Roll-Up Sign Stand	14091	\$ 130.00
DF3000S 12" Stablock Fold & Roll Sign Stand	14092	\$ 162.50
DF3003S 12" Stablock Fold & Roll Sign Stand	14093	\$ 162.50
DF4503 5" RUB3315 Roll-Up Sign Stand	14094	\$ 198.00
DF4700TX 7" RUB3315 Roll-Up Sign Stand	14095	\$ 220.00
Chip seal markers, white with cover, two sided		\$ 0.41
Chip seal markers, yellow with cover, two sided		\$ 0.41

Section 5: Carsonite Products or equal (See Section 1.18 Name Brands)	Lawson Number	Trantex
		Bid Price per Each
Road markers, white, Carsonite CRM-375., flexible 3.75" width x 62" length, with 3" x 12" fluorescent yellow reflective diamond grade VIP installed	5457	\$ 11.95

Section 6: 3M Products	Lawson Number	Newman
		Bid Price per Each
Rolls, 30", red, reflective series DG3 cubed, pressure sensitive	14096	\$ 787.50
Rolls, 30" x 50 yd., white, engineer grade, pressure sensitive, #3200T	1846	\$ 354.38
Rolls, 36" x 50 yd., white, engineer grade, pressure sensitive, #3200T	1847	\$ 425.25
Rolls, 9", white, reflective, series DG3 cubed, pressure sensitive	1759	\$ 236.25
Rolls, 24", white, reflective, series DG3 cubed, pressure sensitive	1760	\$ 630.00
Rolls, 30", white, reflective series DG3 cubed, pressure sensitive	1761	\$ 787.50
Rolls, 36", white, reflective series DG3 cubed, pressure sensitive	11474	\$ 945.00
Rolls, 9", yellow, reflective, engineer grade, pressure sensitive, #3200T	1849	\$ 106.31
Rolls, 9", yellow, reflective, series DG3 cubed, pressure sensitive	1848	\$ 236.25
Rolls, 18", yellow, reflective, series DG3 cubed, pressure sensitive	1850	\$ 472.50
Rolls, 24", yellow, reflective, series DG3 cubed, pressure sensitive	1851	\$ 630.00
Rolls, 30", yellow, reflective, series DG3 cubed, pressure sensitive	1852	\$ 787.50
Rolls, 36", yellow, reflective, series DG3 cubed, pressure sensitive	1853	\$ 945.00
Rolls, 9", fluorescent yellow, reflective, series DG3 cubed, pressure sensitive	10409	\$ 236.25
Rolls, 18", fluorescent yellow, reflective, series DG3 cubed, pressure sensitive	1762	\$ 472.50
Rolls, 24", fluorescent yellow, reflective, series DG3 cubed, pressure sensitive	1763	\$ 630.00
Rolls, 30", fluorescent yellow, reflective, series DG3 cubed, pressure sensitive	1764	\$ 787.50
Rolls, 36", fluorescent yellow, reflective, series DG3 cubed, pressure sensitive	1854	\$ 945.00
Rolls, 24", fluorescent yellow green, reflective, series DG3 cubed, pressure sensitive	1765	\$ 630.00
Rolls, 30", fluorescent yellow green, reflective, series DG3 cubed, pressure sensitive	1766	\$ 787.50

Section 6: 3M Products (cont'd)	Lawson Number	Newman
		Bid Price per Each
Rolls, 18", fluorescent orange, reflective, series DG3 cubed, pressure sensitive	1855	\$ 472.50
Rolls, 30", fluorescent orange, reflective, series DG3 cubed, pressure sensitive	1768	\$ 787.50
Rolls, 36", fluorescent orange, reflective, series DG3 cubed, pressure sensitive	1767	\$ 945.00
Rolls, 18", black, non-reflective, vinyl, clear synthetic liner	1834	\$ 141.75
Rolls, 24", black, non-reflective, vinyl, clear synthetic liner	1835	\$ 189.00
Rolls, 30", black, non-reflective, vinyl, clear synthetic liner	1836	\$ 236.25
Rolls, 36", black, non-reflective, vinyl, clear synthetic liner	1734	\$ 283.50
Rolls, 30", white, non-reflective, vinyl, clear synthetic liner	10410	\$ 236.25
Rolls, 9", transfer tape, clear	1735	\$ 29.53
Rolls, 12", transfer tape, clear	1736	\$ 39.38
Rolls, 24", transfer tape, clear TPM5 transfer prepositioned	12551	\$ 78.75
Rolls, 30", transfer tape, clear TPM5	12552	\$ 98.44
Rolls, 36", transfer tape, clear TPM5	12553	\$ 118.13
24", E C film, brown, clear synthetic liner	1740	\$ 252.00
30", E C film, brown, clear synthetic liner	1741	\$ 315.00
24", E C film, green, clear synthetic liner	1742	\$ 252.00
30", E C film, green, clear synthetic liner	1743	\$ 315.00
24", E C film, blue, clear synthetic liner	1840	\$ 252.00
30", E C film, blue, clear synthetic liner	1841	\$ 315.00
24", E C film, red, clear synthetic liner	1744	\$ 252.00
30", E C film, red, clear synthetic liner	1745	\$ 315.00
36", E C film, red, clear synthetic liner	1839	\$ 378.00
2" roll, red/white, conspicuity marking, series DG3 cubed, pressure sensitive, red/white block, 6" x 6", 983-32	1746	\$ 70.88

Section 6: 3M Products (cont'd) Faces (Faces only NOT complete signs, Does Not include blank) Faces must be pressure sensitive, series DG3 cubed, reflective sheeting and packaged with slip sheeting. Must be packaged with plastic washers.	Lawson Number	Newman Bid Price per Each
Faces: Stop ahead (symbol), 30" fluorescent yellow, series DG3 cubed, material Symbol MUTCD W3-1A	1701	\$ 18.75
Faces: Stop sign, 30 x 30, series DG3 cubed, pre-cut corners	1702	\$ 18.75
Faces: Stop sign, 36 x 36, series DG3 cubed, pre-cut corners	10411	\$ 18.75
Faces: Yield, 30 x 30	1796	\$ 18.75
Faces: Signals ahead, 30 x 30 fluorescent yellow, series DG3 cubed, Symbol MUTCD W3-3	1843	\$ 18.75
Faces: White body raised pavement markings, one-way white lens, 100 per carton	1856	\$ 18.75
Faces: White body raised pavement markings, two-way white lens, 100 per carton	1857	\$ 18.75
Faces: White body raised pavement markings, two-way white/red lens, 100 per carton	1770	\$ 18.75
Faces: Yellow body raised pavement markings, one-way yellow lens, 100 per carton	1860	\$ 18.75
Faces: Yellow body raised pavement markings, two-way yellow lens, 100 per carton	1862	\$ 18.75
Faces: One way pressure sensitive adhesive raised pavement markers white lens, 100 per carton	1773	\$ 18.75
Faces: One way pressure sensitive adhesive raised pavement markers yellow lens, 100 per carton	1858	\$ 18.75
Faces: One way pressure sensitive adhesive raised pavement markers red lens, 100 per carton	1771	\$ 18.75
Faces: Two way pressure sensitive adhesive raised pavement markers white lens, 100 per carton	1861	\$ 18.75
Faces: Two way pressure sensitive adhesive raised pavement markers yellow lens, 100 per carton	1859	\$ 18.75
3M protective overlay film (series 1160), 30" x 50 yards per roll	11475	\$ 18.75
3M protective overlay film (series 1160), 36" x 50 yards per roll	11476	\$ 18.75
3M citrus base cleaner (aerosol)	Item Removed	

Section 6: 3M Products (cont'd) Faces (Faces only NOT complete signs, Does Not include blank) Faces must be pressure sensitive, series DG3 cubed, reflective sheeting and packaged with slip sheeting. Must be packaged with plastic washers. Add 3M protective overlay film (series 1160) to each sign face.	Lawson Number	Newman
		Bid Price per Each
Faces: Stop ahead (symbol), 30" fluorescent yellow, series DG3 cubed, material Symbol MUTCD W3-1A	12558	\$ 33.09
Faces: Stop ahead (symbol), 36" fluorescent yellow, series DG3 cubed, material Symbol MUTCD W3-1A	12558	\$ 47.66
Faces: Stop sign, 30 x 30, series DG3 cubed, pre-cut corners	12559	\$ 33.09
Faces: Stop sign, 36 x 36, series DG3 cubed, pre-cut corners	12560	\$ 47.66
Faces: Yield, 30 x 30	12561	\$ 16.55
Faces: Yield, 36 x 36	14097	\$ 23.83
Faces: Signals ahead, 30 x 30 fluorescent yellow, series DG3 cubed, Symbol MUTCD W3-3	12562	\$ 33.09
Faces: White body raised pavement markings, one-way white lens, 100 per carton	12563	\$ 130.28
Faces: White body raised pavement markings, two-way white lens, 100 per carton	12564	\$ 130.28
Faces: White body raised pavement markings, two-way white/red lens, 100 per carton	12565	\$ 130.28
Faces: Yellow body raised pavement markings, one-way yellow lens, 100 per carton	12566	\$ 130.28
Faces: Yellow body raised pavement markings, two-way yellow lens, 100 per carton	12567	\$ 130.28
Faces: One way pressure sensitive adhesive raised pavement markers white lens, 100 per carton	12568	\$ 333.04
Faces: One way pressure sensitive adhesive raised pavement markers yellow lens, 100 per carton	12569	\$ 333.04
Faces: One way pressure sensitive adhesive raised pavement markers red lens, 100 per carton	12570	\$ 333.04
Faces: Two way pressure sensitive adhesive raised pavement markers white lens, 100 per carton	12571	\$ 333.04
Faces: Two way pressure sensitive adhesive raised pavement markers yellow lens, 100 per carton	12572	\$ 333.04

Section 7: Avery Denison	Lawson Number	Vulcan
		Bid Price per Each
Rolls, 30" x 50 yd., white, engineer grade, pressure sensitive, #3200T	13543	\$ 292.50
Rolls, 36" x 50 yd., white, engineer grade, pressure sensitive, #3200T	13544	\$ 351.00
Rolls, 9", white, reflective, series DG3 cubed, pressure sensitive	13545	\$ 316.13
Rolls, 24", white, reflective, series DG3 cubed, pressure sensitive	13546	\$ 843.00
Rolls, 30", white, reflective, series DG3 cubed, pressure sensitive	13547	\$ 1,053.75
Rolls, 36", white, reflective, series DG3 cubed, pressure sensitive	13548	\$ 1,264.50
Rolls, 9", yellow, reflective, engineer grade, pressure sensitive, #3200T	13549	\$ 87.75
Rolls, 9", yellow, reflective, series DG3 cubed, pressure sensitive	13550	\$ 316.13
Rolls, 18", yellow, reflective, series DG3 cubed, pressure Sensitive	13551	\$ 632.25
Rolls, 24", yellow, reflective, series DG3 cubed, pressure Sensitive	13552	\$ 843.00
Rolls, 30", yellow, reflective, series DG3 cubed, pressure Sensitive	13553	\$ 1,053.75
Rolls, 36", yellow, reflective, series DG3 cubed, pressure Sensitive	13554	\$ 1,264.50
Rolls, 9", fluorescent yellow, reflective, series DG3 cubed, pressure sensitive	13555	\$ 316.13
Rolls, 18", fluorescent yellow, reflective, series DG3 cubed, pressure sensitive	13556	\$ 632.25
Rolls, 24", fluorescent yellow, reflective, series DG3 cubed, pressure sensitive	13557	\$ 843.00
Rolls, 30", fluorescent yellow, reflective, series DG3 cubed, pressure sensitive	13558	\$ 1,053.75
Rolls, 36", fluorescent yellow, reflective, series DG3 cubed, pressure sensitive	13559	\$ 1,264.50
Rolls, 24", fluorescent yellow green, reflective, series DG3 cubed, pressure sensitive	13560	\$ 843.00
Rolls, 30", fluorescent yellow green, reflective, series DG3 cubed, pressure sensitive	13561	\$ 1,053.75
Rolls, 18", fluorescent orange, reflective, series DG3 cubed, pressure sensitive	13562	\$ 632.25
Rolls, 30", fluorescent orange, reflective, series DG3 cubed, pressure sensitive	13563	\$ 1,053.75

Section 7: Avery Denison (cont'd)	Lawson Number	Vulcan
		Bid Price per Each
Rolls, 36", fluorescent orange, reflective, series DG3 cubed, pressure sensitive	13564	\$1,264.50
Rolls, 24", black, non-reflective, vinyl, clear synthetic liner	13566	\$ 318.57
Rolls, 30", black, non-reflective, vinyl, clear synthetic liner	13567	\$ 398.20
Rolls, 36", black, non-reflective, vinyl, clear synthetic liner	13568	\$ 477.85
Rolls, 30", white, non-reflective, vinyl, clear synthetic liner	13569	\$ 398.20
Rolls, 9", transfer tape, clear	13570	\$ 65.25
Rolls, 12", transfer tape, clear	13571	\$ 87.00
24", E C film, brown, clear synthetic liner	13572	\$ 276.00
30", E C film, brown, clear synthetic liner	13573	\$ 345.00
24", E C film, green, clear synthetic liner	13574	\$ 276.00
30", E C film, green, clear synthetic liner	13575	\$ 345.00
24", E C film, blue, clear synthetic liner	13576	\$ 276.00
30", E C film, blue, clear synthetic liner	13577	\$ 345.00
24", E C film, red, clear synthetic liner	13578	\$ 276.00
30", E C film, red, clear synthetic liner	13579	\$ 345.00
36", E C film, red, clear synthetic liner	13580	\$ 414.00
2" roll, red/white, conspicuity marking, series DG3 cubed, pressure sensitive, red/white block, 6" x 6", 983-32	13581	\$ 113.89

Section 7: Avery Denison (cont'd) Faces (Faces only NOT complete signs, Does Not include blank) Faces must be pressure sensitive, series DG3 cubed, reflective sheeting and packaged with slip sheeting. Must be packaged with plastic washers.	Lawson Number	Vulcan Bid Price per Each
Faces: Stop ahead (symbol), 30" fluorescent yellow, series DG3 cubed, material Symbol MUTCD W3-1A	13582	\$ 18.98
Faces: Stop sign, 30 x 30, series DG3 cubed, pre-cut corners	13583	\$ 17.94
Faces: Stop sign, 36 x 36, series DG3 cubed, pre-cut corners	13584	\$ 25.83
Faces: Yield, 30 x 30	13585	\$ 9.13
Faces: Signals ahead, 30 x 30 fluorescent yellow, series DG3 cubed, Symbol MUTCD W3-3	13586	\$ 19.48
Faces: White body raised pavement markings, one-way white lens, 100 per carton	13587	\$ 205.00
Faces: White body raised pavement markings, two-way white lens, 100 per carton	13588	\$ 205.00
Faces: White body raised pavement markings, two-way white/red lens, 100 per carton	13589	\$ 205.00
Faces: Yellow body raised pavement markings, one-way yellow lens, 100 per carton	13590	\$ 205.00
Faces: Yellow body raised pavement markings, two-way yellow lens, 100 per carton	13591	\$ 205.00
Faces: One way pressure sensitive adhesive raised pavement markers white lens, 100 per carton	13592	\$ 205.00
Faces: One way pressure sensitive adhesive raised pavement markers yellow lens, 100 per carton	13593	\$ 205.00
Faces: One way pressure sensitive adhesive raised pavement markers red lens, 100 per carton	13594	\$ 205.00
Faces: Two way pressure sensitive adhesive raised pavement markers white lens, 100 per carton	13595	\$ 205.00
Faces: Two way pressure sensitive adhesive raised pavement markers yellow lens, 100 per carton	13596	\$ 205.00
Protective overlay film (series 1160), 30" x 50 yards	13597	\$ 517.50
Protective overlay film (series 1160), 36" x 50 yards	13598	\$ 621.00

Section 8: Cutting Knives	Lawson Number	Osburn
		Bid Price per Each
CB09UA-5 cutting knives for Western Graphtec cutting pro 300-100	1783	\$ 230.50
CB15U-5 cutting knives for Western Graphtec cutting pro 300-100	1864	\$ 230.50

Section 9: Banding Materials	Lawson Number	Core Products
		Bid Price per Each
Stainless steel, 3/4" x 100' x .030 coil in dispensing box, type 201 universal		\$ 41.25
3/4" wide stainless steel top split wing seal		\$ 0.22
Flared leg stainless sign bracket with bolt & washer		\$ 1.40

Section 10: Safety Vests	Lawson Number	Dobie Supply
		Bid Price per Each
Safetey vests, ML Kishigo Ultra-Cool mesh, contrasting #1056 (or equal), ANSI/ISEA 107 2010 Class 2 compliant, zipper front closure, 2" wide reflective material with 4.5" contrasting color, inside left chest 2-tier 4-division pencil pocket, lower right inside patch pocket, with Mic Tab on front left chest, with Road and Bridge imprinted on back, Size: M	10412	\$ 12.90
Safetey vests, ML Kishigo Ultra-Cool mesh, contrasting #1056 (or equal), ANSI/ISEA 107 2010 Class 2 compliant, zipper front closure, 2" wide reflective material with 4.5" contrasting color, inside left chest 2-tier 4-division pencil pocket, lower right inside patch pocket, with Mic Tab on front left chest, with Road and Bridge imprinted on back, Size: L	10413	\$ 12.90
Safetey vests, ML Kishigo Ultra-Cool mesh, contrasting #1056 (or equal), ANSI/ISEA 107 2010 Class 2 compliant, zipper front closure, 2" wide reflective material with 4.5" contrasting color, inside left chest 2-tier 4-division pencil pocket, lower right inside patch pocket, with Mic Tab on front left chest, with Road and Bridge imprinted on back, Size: XL	10414	\$ 12.90

Section 10: Safety Vests (cont'd)	Lawson Number	Dobie Supply
		Bid Price per Each
Safetey vests, ML Kishigo Ultra-Cool mesh, contrasting #1056 (or equal), ANSI/ISEA 107 2010 Class 2 compliant, zipper front closure, 2" wide reflective material with 4.5" contrasting color, inside left chest 2-tier 4-division pencil pocket, lower right inside patch pocket, with Mic Tab on front left chest, with Road and Bridge imprinted on back, Size: XXL	10415	\$ 12.90
Safetey vests, ML Kishigo Ultra-Cool mesh, contrasting #1056 (or equal), ANSI/ISEA 107 2010 Class 2 compliant, zipper front closure, 2" wide reflective material with 4.5" contrasting color, inside left chest 2-tier 4-division pencil pocket, lower right inside patch pocket, with Mic Tab on front left chest, with Road and Bridge imprinted on back, Size: XXXL	10416	\$ 12.90
Safetey vests, ML Kishigo Ultra-Cool mesh, contrasting #1056 (or equal), ANSI/ISEA 107 2010 Class 2 compliant, zipper front closure, 2" wide reflective material with 4.5" contrasting color, inside left chest 2-tier 4-division pencil pocket, lower right inside patch pocket, with Mic Tab on front left chest, with Road and Bridge imprinted on back, Size: 4XL	12554	\$ 14.00
Safetey vests, ML Kishigo Ultra-Cool mesh, contrasting #1056 (or equal), ANSI/ISEA 107 2010 Class 2 compliant, zipper front closure, 2" wide reflective material with 4.5" contrasting color, inside left chest 2-tier 4-division pencil pocket, lower right inside patch pocket, with Mic Tab on front left chest, with Road and Bridge imprinted on back, Size: 5XL	12555	\$ 14.00

Section 11: Stop/Slow Paddles	Lawson Number	Trantex
		Bid Price per Each
Stop/slow paddles, 24" aluminum, Diamond Grade reflective with 12" handle	10417	\$ 89.00
Extension handles, telescopic with 2 height settings for 6' and 7' height	10418	\$ 16.75

Section 12: Miscellaneous	Lawson Number	Trantex
		Bid Price per Each
Yellow water base traffic paint for stripping roads in	1775	\$14.55
White water base traffic paint for stripping roads in gallons	1776	\$14.35
Blue water base traffic paint for stripping roads in gallons	1777	\$10.50
Red water base traffic paint for stripping roads in gallons	1778	\$11.95
Black water base traffic paint for stripping roads in gallons	1779	\$10.10
Glass beads, in pounds, 50 pounds per bag	1780	\$0.82
Bitumem adhesive for raised pavement markings in pounds	1772	\$0.40



COUNTY PURCHASING AGENT
Fort Bend County, Texas

Vendor Information

Jaime Kovar
County Purchasing Agent

Office (281) 341-8640

Legal Company Name (top line of W9)	Core Products LLC		
Business Name (if different from legal name)			
Federal ID # or S.S. #	47-5152316	DUNS #	878512771
Type of Business	<input checked="" type="checkbox"/> Corporation/LLC <input type="checkbox"/> Sole Proprietor/Individual	<input type="checkbox"/> Partnership <input type="checkbox"/> Tax Exempt Organization	Age in Business? 6 Yrs
Publicly Traded Business	<input checked="" type="checkbox"/> No <input type="checkbox"/> Yes Ticker Symbol _____		
Remittance Address	PO Box 5137		
City/State/Zip	Covington, LA 70434		
Physical Address	74525 Oil Row		
City/State/Zip	Covington, LA 70435		
Phone/Fax Number	Phone: 877-578-0588	Fax: 877-489-2545	
Contact Person	Chris McDonald		
E-mail	Sales@Coreproductsusa.com		
Check all that apply to the company listed above and provide certification number.	DBE-Disadvantaged Business Enterprise _____	Certification # _____	
	SBE-Small Business Enterprise _____	Certification # _____	
	HUB -Texas Historically Underutilized Business _____	Certification # _____	
	WBE-Women's Business Enterprise _____	Certification # _____	
Company's gross annual receipts	<\$500,000 _____	\$500,000-\$4,999,999 <input checked="" type="checkbox"/>	
	\$5,000,000-\$16,999,999 _____	\$17,000,000-\$22,399,999 _____	
	>\$22,400,000 _____		
NAICs codes (Please enter all that apply)	332999		
Signature of Authorized Representative			
Printed Name	Chris McDonald		
Title	Sales Manager		
Date	1/13/2021		

THIS FORM MUST BE SUBMITTED WITH THE SOLICITATION RESPONSE

*Fort Bend County, Texas
Invitation for Bid*



*Term Contract for the Purchase of Traffic Signs, Posts and Supplies
BID 21-048*

SUBMIT BIDS TO:

Fort Bend County
Purchasing Department
Travis Annex
301 Jackson, Suite 201
Richmond, TX 77469

Note: All correspondence must include the term "Purchasing Department" in address to assist in proper delivery.

SUBMIT NO LATER THAN:

Tuesday, January 19, 2021
2:00 PM (Central)

LABEL ENVELOPE:

BID 21-048
TRAFFIC SIGNS, POSTS, SUPPLIES

ALL BIDS MUST BE RECEIVED IN AND TIME/DATE STAMPED BY THE PURCHASING OFFICE OF FORT BEND COUNTY BEFORE THE SPECIFIED TIME/DATE STATED ABOVE.

BIDS RECEIVED AS REQUIRED WILL THEN BE OPENED AND PUBLICLY READ.

BIDS RECEIVED AFTER THE SPECIFIED TIME, WILL BE RETURNED UNOPENED.

Results will not be given by phone.
Results will be provided to bidder in writing
after the Commissioners Court awards.

Requests for information must be in
writing and directed to:
Cheryl Krejci, CPPB
Senior Buyer
cheryl.krejci@fortbendcountytexas.gov

Vendor Responsibilities:

- Download and complete any addendums. (Addendums will be posted on the Fort Bend County website no later than 48 hours prior to bid opening)
- Submit response in accordance with requirements stated on the cover of this document.
- DO NOT submit responses via email or fax.

1.0 GENERAL REQUIREMENTS:

- 1.1 Read this entire document carefully. Follow all instructions. You are responsible for fulfilling all requirements and specifications. Be sure you understand them.
- 1.2 General Requirements apply to all advertised bids, however, these may be superseded, whole or in part, by the scope, special requirements, specifications, special specifications or other data contained herein.
- 1.3 Governing Law: Bidder is advised that these requirements shall be fully governed by the laws of the State of Texas and that Fort Bend County may request and rely on advice, decisions and opinions of the Attorney General of Texas and the County Attorney concerning any portion of these requirements.
- 1.4 Bid Document Completion: Fill out, initial each page, sign, and return ONE (1) complete bid document to the Fort Bend County Purchasing Department. An authorized representative of the bidder must sign the Contract Sheet. Do not complete the date at the top of the contract sheet. The bid document must be in a sealed envelope marked with the appropriate bid number and title. The contract will be binding only when signed by the County Judge, Fort Bend County and a purchase order authorizing the item(s) desired has been issued. The use of correction fluid is not acceptable and may result in the disqualification of bid. If an error is made, the bidder must draw a line through error and initial each change. All response, typed or written, information must be clear and legible.

If a pricing form in Excel is included and posted on the County's website amongst this bid document, the Vendor must download, complete and save the Excel (not a PDF of the Excel file) file of the pricing form on a CD or flash drive. The Excel file on the CD or flash drive must be downloadable by the Purchasing Department in order to copy and paste the vendor's pricing to the County's tabulation. The CD or flash drive must be labeled and included in the same sealed envelope with the respondent's completed bid document along with a printed copy of the pricing form completed by the vendor.

- 1.5 Bid Returns: Bidders must return completed bid document to the Fort Bend County Purchasing Department at 301 Jackson, Suite 201, Richmond, Texas no later than 2:00 P.M. on the date specified. Late bids will not be accepted. Bids must be submitted in a sealed envelope, addressed as follows: Fort Bend County Purchasing Agent, Travis Annex, 301 Jackson, Suite 201, Richmond, Texas 77469.
- 1.6 Governing Document: In the event of any conflict between the terms and provisions of these requirements and the specifications, the specifications shall govern. In the event of any conflict of interpretation of any part of this overall document, Fort Bend County's interpretation shall govern.

Initials of Bidder: _____



- 1.7 Addenda: No interpretation of the meaning of the drawings, specifications or other bid documents will be made to any bidder orally. All requests for such interpretations must be made in writing addressed to Ms. Cheryl Krejci, Senior Buyer, 301 Jackson, Suite 201, Richmond, Texas 77469, e-mail: cheryl.krejci@fortbendcountytexas.gov. Any and all interpretations and any supplemental instructions will be in the form of written addenda to the contract documents which will be posted on Fort Bend County's website. Addenda will **ONLY** be issued by the Fort Bend County Purchasing Agent. It is the sole responsibility of each bidder to insure receipt of any and all addenda. All addenda issued will become part of the contract documents. Bidders must sign and include addendum in the returned bid package. Deadline for submission of questions and/or clarification is **Tuesday, January 12, 2021 at 9:00 a.m. (CST)**. Requests received after the deadline will not be responded to due to the time constraints of this bid process.
- 1.8 Hold Harmless Agreement: Contractor shall indemnify and hold Fort Bend County harmless from all claims for personal injury, death and/or property damage arising from any cause whatsoever, resulting directly or indirectly from contractor's performance. Contractor shall procure and maintain, with respect to the subject matter of this bid, appropriate insurance coverage including, as a minimum, public liability and property damage with adequate limits to cover contractor's liability as may arise directly or indirectly from work performed under terms of this bid. Certification of such coverage must be provided to the County upon request.
- 1.9 Waiver of Subrogation: Bidder and bidder's insurance carrier waive any and all rights whatsoever with regard to subrogation against Fort Bend County as an indirect party to any suit arising out of personal or property damages resulting from bidder's performance under this agreement.
- 1.10 Severability: If any section, subsection, paragraph, sentence, clause, phrase or word of these requirements or the specifications shall be held invalid, such holding shall not affect the remaining portions of these requirements and the specifications and it is hereby declared that such remaining portions would have been included in these requirements and the specifications as though the invalid portion had been omitted.
- 1.11 Bonds: If this bid requires submission of bid guarantee and performance bond, there will be a separate page explaining those requirements. Bids submitted without the required bid bond or cashier's checks are not acceptable. Bond/s or cashier's check must be complete with all required signatures.
- 1.12 Taxes: Fort Bend County is exempt from all federal excise, state and local taxes unless otherwise stated in this document. Fort Bend County claims exemption from all sales and/or use taxes under Chapter 20, Title 122a, Vernon's Texas Civil Statutes, as amended. Texas Limited Sales Tax Exemption Certificates will be furnished upon written request to the Fort Bend County Purchasing Department.

Initials of Bidder: _____

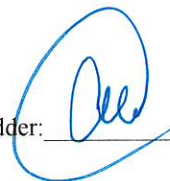

- 1.13 Fiscal Funding: A multi-year lease or lease/purchase arrangement (if requested by the specifications), or any contract continuing as a result of an extension option, must include fiscal funding out. If, for any reason, funds are not appropriated to continue the lease or contract, said lease or contract shall become null and void. After expiration of the lease, leased equipment shall be removed by the bidder from the using department without penalty of any kind or form to Fort Bend County. All charges and physical activity related to delivery, installation, removal and redelivery shall be the responsibility of the bidder.
- 1.14 Pricing: Prices for all goods and/or services shall be firm for the duration of this contract and shall be stated in the bid spreadsheet. Prices shall be all inclusive. No price changes, additions, or subsequent qualifications will be honored during the course of the contract. All prices must be written in ink or typewritten. Pricing on all transportation, freight, and other charges are to be prepaid by the contractor and included in the bid prices. If there are any additional charges of any kind, other than those mentioned above, specified or unspecified, bidder MUST indicate the items required and attendant costs or forfeit the right to payment for such items.
- 1.15 Silence of Specifications: The apparent silence of specifications as to any detail, or the apparent omission from it of a detailed description concerning any point, shall be regarded as meaning that only the best commercial practice is to prevail and that only material and workmanship of the finest quality are to be used. All interpretations of specifications shall be made on the basis of this statement. The items furnished under this contract shall be new, unused of the latest product in production to commercial trade and shall be of the highest quality as to materials used and workmanship. Manufacturer furnishing these items shall be experienced in design and construction of such items and shall be an established supplier of the item bid.
- 1.16 Supplemental Materials: Bidders are responsible for including all pertinent product data in the returned bid package. Literature, brochures, data sheets, specification information, completed forms requested as part of the bid package and any other facts which may affect the evaluation and subsequent contract award should be included. Materials such as legal documents and contractual agreements, which the bidder wishes to include as a condition of the bid, must also be in the returned bid package. Failure to include all necessary and proper supplemental materials may be cause to reject the entire bid.
- 1.17 Material Safety Data Sheets: Under the "Hazardous Communication Act", commonly known as the "Texas Right To Know Act", a bidder must provide to County and using departments, with each delivery, material safety data sheets, which are, applicable to hazardous substances defined in the Act. Bidders are obligated to maintain a current, updated file in the Fort Bend County Purchasing Department. Failure of the bidder to maintain such a file will be cause to reject any bid applying thereto.

Initials of Bidder:



- 1.18 Name Brands: Specifications may reference name brands and model numbers. It is not the intent of Fort Bend County to restrict these bids in such cases, but to establish a desired quality level of merchandise or to meet a pre-established standard due to like existing items. Bidders may offer items of equal stature and the burden of proof of such stature rests with them. Fort Bend County shall act as sole judge in determining equality and acceptability of products offered.
- 1.19 Color Selection: Determination of colors of materials is a right reserved by the using department unless otherwise specified in the bid. Unspecified colors shall be quoted as standard colors, not colors, which require up charges or special handling. Unspecified fabrics or vinyl should be construed as medium grade. If bidder fails to get color/material approvals prior to delivery of merchandise, the using department may refuse to accept the items and demand correct shipment without penalty, subject to other legal remedies.
- 1.20 Evaluation: Evaluation shall be used as a determinant as to which bid items or services are the most efficient and/or most economical for the County. It shall be based on all factors, which have a bearing on price and performance of the items in the user environment. All bids are subject to tabulation by the Fort Bend County Purchasing Department and recommendation to Fort Bend County Commissioners Court. Compliance with all bid requirements, delivery and needs of the using department are considerations in evaluating bids. Pricing is NOT the only criteria for making a recommendation. The Fort Bend County Purchasing Department reserves the right to contact any bidder, at any time, to clarify, verify or request information with regard to any bid.
- 1.21 Inspections: Fort Bend County reserves the right to inspect any item(s) or service location for compliance with specifications and requirements and needs of the using department. If a bidder cannot furnish a sample of a bid item, where applicable, for review, or fails to satisfactorily show an ability to perform, the County can reject the bid as inadequate.
- 1.22 Testing: Fort Bend County reserves the right to test equipment, supplies, material and goods bid for quality, compliance with specifications and ability to meet the needs of the user. Demonstration units must be available for review. Should the goods or services fail to meet requirements and/or be unavailable for evaluation, the bid is subject to rejection.
- 1.23 Disqualification of Bidder: Upon signing this bid document, a bidder offering to sell supplies, materials, services, or equipment to Fort Bend County certifies that the bidder has not violated the antitrust laws of this state codified in section 15.01, et seq., Business & Commerce Code, or the federal antitrust laws, and has not communicated directly or indirectly the bid made to any competitor or any other person engaged in such line of business. Any or all bids may be rejected if the County believes that collusion exists among the bidders. Bids in which the prices are

Initials of Bidder: _____



obviously unbalanced may be rejected. If multiple bids are submitted by a bidder and after the bids are opened, one of the bids is withdrawn, the result will be that all of the bids submitted by that bidder will be withdrawn; however, nothing herein prohibits a vendor from submitting multiple bids for different products or services.

- 1.24 Awards: Fort Bend County reserves the right to award this contract on the basis of lowest and best bid in accordance with the laws of the State of Texas, to waive any formality or irregularity, to make awards to more than one bidder, to reject any or all bids. In the event the lowest dollar bidder meeting specifications is not awarded a contract, the bidder may appear before the Commissioners Court and present evidence concerning his responsibility. An award is final only upon formal execution by the Fort Bend County Commissioners Court or the Fort Bend County Purchasing Agent. Fort Bend County reserves the right to withdraw any award until execution by the proper authority.
- 1.25 Assignment: The successful vendor may not assign, sell or otherwise transfer this contract without written permission of Fort Bend County Commissioners Court.
- 1.26 Term Contracts: If the contract is intended to cover a specific time period, said time will be given in the specifications under scope.
- 1.27 Maintenance: Maintenance required for equipment bid should be available in Fort Bend County by a manufacturer authorized maintenance facility. Costs for this service shall be shown on the bid sheet as requested or on a separate sheet, as required. If Fort Bend County opts to include maintenance, it shall be so stated in the purchase order and said cost will be included. Service will commence only upon expiration of applicable warranties and should be priced accordingly.
- 1.28 Contract Obligation: Fort Bend County Commissioners Court must award the contract and the County Judge or other person authorized by the Fort Bend County Commissioners Court must sign the contract before it becomes binding on Fort Bend County or the bidders. Department heads are not authorized to sign agreements for Fort Bend County. Binding agreements shall remain in effect until all products and/or services covered by this purchase have been satisfactorily delivered and accepted.
- 1.29 Title Transfer: Title and Risk of Loss of goods shall not pass to Fort Bend County until Fort Bend County actually receives and takes possession of the goods at the point or points of delivery. Receiving times may vary with the using department. Generally, deliveries may be made between 8:30 a.m. and 4:00 p.m., Monday through Friday. Bidders are advised to consult the using department for instructions. The place of delivery shall be shown under the "Special Requirement" section of this bid document and/or on the Purchase Order as a "Ship To:" address.
- 1.30 Purchase Order and Delivery: The successful bidder shall not deliver products or

Initials of Bidder:



provide services without a Fort Bend County Purchase Order, signed by an authorized agent of the Fort Bend County Purchasing Department. The fastest, most reasonable delivery time shall be indicated by the bidder in the proper place on the bid sheet. Any special information concerning delivery should also be included, on a separate sheet, if necessary. All items shall be shipped F.O.B. inside delivery unless otherwise stated in the specifications. This shall be understood to include bringing merchandise to the appropriate room or place designated by the using department. Every tender or delivery of goods must fully comply with all provisions of these requirements and the specifications including time, delivery and quality. Nonconformance shall constitute a breach, which must be rectified prior to expiration of the time for performance. Failure to rectify within the performance period will be considered cause to reject future deliveries and cancellation of the contract by Fort Bend County without prejudice to other remedies provided by law. Where delivery times are critical, Fort Bend County reserves the right to award accordingly.

- 1.31 Contract Extension: Extensions may be made only by written agreement between Fort Bend County and the bidder. Any price escalations are limited to those stated by the bidder in the original bid.
- 1.32 Termination: Fort Bend County reserves the right to terminate the contract for default if Seller breaches any of the terms therein, including warranties of bidder or if the bidder becomes insolvent or commits acts of bankruptcy. Such right of termination is in addition to and not in lieu of any other remedies, which Fort Bend County may have in law or equity. Default may be construed as, but not limited to, failure to deliver the proper goods and/or services within the proper amount of time, and/or to properly perform any and all services required to Fort Bend County's satisfaction and/or to meet all other obligations and requirements. Contracts may be terminated without cause upon thirty (30) days written notice to either party unless otherwise specified.
- 1.33 Recycled Materials: Fort Bend County encourages the use of products made of recycled materials and shall give preference in purchasing to products made of recycled materials if the products meet applicable specifications as to quantity and quality. Fort Bend County will be the sole judge in determining product preference application.
- 1.34 Interlocal Participation: Additional governmental entities may purchase from this bid. Vendor agrees to accept purchase orders from those participating entities and to invoice each entity separately.
- 1.35 Escalation Clause: Successful bidder may apply for a price increase to the Fort Bend County Purchasing Agent. The County Purchasing Agent will review, and, if increase is deemed warranted, place the request on Fort Bend County's Commissioners Court agenda for their action of approval or disapproval. Approval by the County's Commissioner's Court is required. Any proposed price increase will

Initials of Bidder: _____



only be the amount increased to the vendor from his/her supplier. The price increase request must be stated on the vendor's letterhead with the bid number and name in the subject including, in columns, for each item: item description, original bid price, percent of increase, and the total cost of the original bid price including the increased dollar amount. Written documentation from the vendor's supplier of the increase notice must be provided to the Purchasing Agent at time of increase request. No application for a price increase may be submitted within the first six (6) months of this contract. Increase requests of more than 25% of the original bid price will not be considered.

- 1.36 Modifications: This instrument contains the entire Contract between the parties relating to the rights herein granted and obligations herein assumed. Any oral or written representations or modifications concerning this instrument shall be of no force and effect excepting a subsequent written modification signed by both parties hereto.

2.0 TERMS & CONDITIONS:

- 2.1 Seller to Package Goods: Seller will package goods in accordance with good commercial practice. Each delivery container shall be clearly and permanently marked as follows (a) Seller's name and address; (b) Consignee's name, address and purchase order number and the bid number if applicable; (c) Container number and total number of containers (e.g. box 1 of 4 boxes); and (d) the number of the container bearing the packing slip. Seller shall bear cost of packaging unless otherwise provided. Goods shall be suitably packed to secure lowest transportation costs and to conform to requirements of common carriers and any applicable specifications. Fort Bend County's count or weight shall be final and conclusive on shipments not accompanied by packing list.
- 2.2 Shipment Under Reservation Prohibited: Seller is not authorized to ship goods under reservation and no tender of a bill of lading will operate as a tender of goods.
- 2.3 Title and Risk of Loss: The title and risk of loss of the goods shall not pass to the County until a County employee actually receives and takes possession of the goods at the point or points of delivery.
- 2.4 Delivery Terms: F.O.B. Destination Freight Prepaid, Inside Delivery, unless delivery terms are specified otherwise on Purchase Order.
- 2.5 No Replacement of Defective Tender: Every tender or delivery of goods must fully comply with all provisions of the Purchase Order as to time of delivery, quality and the like. If a tender is made which does not fully conform, this shall constitute a breach and Seller shall not have the right to substitute a conforming tender.
- 2.6 Place of Delivery: The place of delivery shall be that set forth in the block of the

Initials of Bidder: 

purchase order entitled "Ship To". Any change thereto shall be effective by modification as provided for in Clause number 2.20 "Modifications", hereof. The terms of this agreement are "no arrival, no sale", at the discretion of Fort Bend County.

2.7 Invoices and Payments:

2.7.1 Seller shall submit separate invoices, in duplicate. Invoices shall indicate the purchase order number and the bid number if applicable. Invoices shall be itemized and transportation charges, if any, shall be listed separately. A copy of the bill of lading, and the freight waybill when applicable should be attached to the invoice.

2.7.2 Fort Bend County's obligation is payable only and solely from funds available for the purpose of this purchase. Lack of funds shall render the order null and void to the extent funds are not available and any delivered but unpaid goods will be returned to Seller by the county.

2.7.3 Do not include Federal Excise, State, or City Sales Tax. Fort Bend County is a tax-exempt governmental entity.

2.8 Gratuities: Fort Bend County may, by written notice to the Seller, cancel any order without liability, if it is determined by the County that gratuities, in the form of entertainment, gifts, or otherwise were offered or given by the Seller, or any agent or representative of the Seller to any officer or employee of Fort Bend County with a view toward securing an order. In the event an order is canceled by the County pursuant to this provision, the County shall be entitled, in addition to any other rights and remedies, to recover or withhold the amount of the cost incurred by Seller in providing such gratuities.

2.9 Special Tools and Test Equipment: If the price stated on the face of an order includes the cost of any special tooling or special test equipment fabricated or required by Seller for the purpose of filing this order, such special tooling equipment and any process sheets related thereto shall become the property of the County and to the extent feasible shall be identified by the Seller as such.

2.10 Warranty/Price:

2.10.1 The price to be paid by the County shall be that contained in Seller's bid which Seller warrants to be no higher than Seller's current prices on orders by others for products of the kind and specification covered by an order for similar quantities under similar or like conditions and methods of purchase. In the event Seller breaches this warranty the prices of the items shall be reduced to the Seller's current prices on orders by others. Fort Bend County may cancel this contract without liability.

Initials of Bidder: 

- 2.10.2 The Seller warrants that no person or selling agency has been employed or retained to solicit or secure any County order based upon any agreement or understanding for commission, percentage, brokerage, or contingent fee excepting bona fide employees of bona fide established commercial or selling agencies maintained by the Seller for the purpose of securing business. A breach or violation of this warranty gives the County the right, in addition to any other right or rights, to cancel this contract without liability.
- 2.11 Warranty Product: Seller shall not limit or exclude any implied warranties and any attempt to do so shall render an order voidable at the option of the County. Seller warrants that the goods furnished will conform to the specifications, drawings, and description listed in the bid invitation and purchase order as applicable, and to the sample(s) furnished by Seller if any. In the event of a conflict between the specifications, drawings, and descriptions, the specifications shall govern.
- 2.12 Safety Warranty: Seller warrants that the product sold to Fort Bend County shall conform to the standards promulgated by the U.S. Department of Labor under the Occupational Safety and Health Act of 1970. In the event the product does not conform to OSHA standards, the County may return the product for correction or replacement at the Seller's expense. In the event Seller fails to make the appropriate correction within 10 days, correction made by the County will be at Seller's expense.
- 2.13 No Warranty by Fort Bend County Against Infringements: As part of a contract for sale Seller agrees to ascertain whether goods manufactured in accordance with the specifications will give rise to the rightful claim of any third person by way of infringement. Fort Bend County makes no warranty that the production of goods according to the specification will not give rise to such a claim and in no event shall Fort Bend County be liable to Seller for indemnification in the event the Seller is sued on the grounds of infringement or the like. If Seller is of the opinion that an infringement will result, he will notify Fort Bend County to this effect in writing within two days after the receiving Purchase Order. If the County does not receive notice and is subsequently held liable for the infringement, Seller will defend and save the County harmless. If Seller in good faith ascertains that production of the goods in accordance with the specifications will result in infringement, this contract shall be null and void except that the County will pay Seller the reasonable cost of his search as to infringements.
- 2.14 Right of Inspection: The County shall have the right to inspect the goods at delivery before accepting them.
- 2.15 Cancellation: Fort Bend County shall have the right to cancel for default all or any part of the undelivered portion of an order if Seller breaches any of the terms hereof including warranties of Seller, or if the Seller becomes insolvent or files for protection under the bankruptcy laws. Such rights of cancellation are in addition to and not in lieu of any other remedies, which Fort Bend County may have in law or



equity.

- 2.16 Termination: The performance of work under a Purchase Order may be terminated in whole or in part by the County in accordance with this provision. Termination of work there under shall be effected by the delivery to the Seller of a "Notice of Termination" specifying the extent to which performance of work under the order is terminated and the date upon which such termination becomes effective. Such right of termination is in addition to and not in lieu of rights of Fort Bend County set forth in Clause 15 herein.
- 2.17 Force Majeure: Force Majeure means a delay encountered by a party in the performance of its obligations under this Agreement, which is caused by an event beyond the reasonable control of that party. Without limiting the generality of the foregoing, "Force Majeure" shall include but not be restricted to the following types of events: acts of God or public enemy; acts of governmental or regulatory authorities; fires, floods, epidemics or serious accidents; unusually severe weather conditions; strikes, lockouts, or other labor disputes; and defaults by subcontractors.
- In the event of a Force Majeure, the affected party shall not be deemed to have violated its obligations under this Agreement, and the time for performance of any obligations of that party shall be extended by a period of time necessary to overcome the effects of the Force Majeure, provided that the foregoing shall not prevent this Agreement from terminating in accordance with the termination provisions. If any event constituting a Force Majeure occurs, the affected party shall notify the other parties in writing, within twenty-four (24) hours, and disclose the estimated length of delay, and cause of the delay.
- 2.18 Assignment-Delegation: No right or interest in an order shall be assigned or delegation of any obligation made by Seller without the written permission of Fort Bend County. Any attempted assignment or delegation by Seller shall be wholly void and totally ineffective for all purposes unless made in conformity with this paragraph.
- 2.19 Waiver: No claim or right arising out of a breach of any contract can be discharged in whole or in part by a waiver or renunciation of the claim or right unless the waived or renunciation is supported by consideration and is in writing signed by the aggrieved party.
- 2.20 Modification: A Purchase Order can be modified or rescinded only by a writing signed by both of the parties or their duly authorized agents.
- 2.21 Parol Evidence: This writing is intended by the parties as a final expression of their agreement and is intended also as a complete and exclusive statement of the terms of this agreement. No course of prior dealings between the parties and no usage of the trade shall be relevant to supplement or explain any terms rendered under this agreement and shall not be relevant to determine the meaning of this agreement even

Initials of Bidder:



though the accepting or acquiescing party has knowledge of the performance and opportunity for objection. Whenever a term defined by the Uniform Commercial Code is used in this agreement, the definition contained in the Code is to control.

- 2.22 Applicable Law: This agreement shall be governed by the Uniform Commercial Code. Whenever the term "Uniform Commercial Code" is used it shall be construed as meaning the Uniform Commercial Code as adopted in the State of Texas and in effective on the date of the purchase order.
- 2.23 Advertising: Seller shall not advertise or publish, without the County's prior consent the fact that Fort Bend County has entered into any contract, except to the extent necessary to comply with proper requests for information from an authorized representative of the federal, state, or local government.
- 2.24 Right to Assurance: Whenever the County in good faith has reason to question the other party's intent to perform. The County may demand that the other party give written assurance of his intent to perform. In the event that a demand is made and no assurance is given within five (5) days, the County may treat this failure as an anticipatory repudiation of the contract.
- 2.25 Venue: Both parties agree that venue for any litigation arising from this contract shall lie in Richmond, Fort Bend County, Texas.
- 2.26 Prohibition Against Personal Interest in Contracts: No officer or employee of the County shall have a financial interest, direct or indirect, in any contract with the County, or shall be financially interested, directly or indirectly, in the sale to the County of any land, materials, supplies, or service, except on behalf of the County as an officer or employee. Any willful violation of this section shall constitute malfeasance in office, and any officer or employee guilty thereof shall be subject to disciplinary action under applicable laws, statutes and codes of the State of Texas. Any violation of this section, with the knowledge, expressed or implied of the person or corporation contracting with the County shall render the contract involved voidable by the County Commissioners Court.

3.0 SCOPE:

It is the intent of Fort Bend County to contract with one (1) or more vendors to provide traffic signs, posts and supplies for Fort Bend County as specified herein.

4.0 TERM OF CONTRACT:

The term of this contract is **April 1, 2021 through March 31, 2022**, renewable annually for four (4) years (through 31 March 2026) under the same terms and conditions if mutually agreeable by both parties. Either party for any reason may terminate this contract by giving thirty (30) days written notice of the intent to terminate.



5.0 TEXAS ETHICS COMMISSION FORM 1295:

- 5.1 Effective January 1, 2016 all contracts executed by Commissioners Court, regardless of the dollar amount, will require completion of Form 1295 "Certificate of Interested Parties", per the new Government Code Statute §2252.908. All vendors submitting a response to a formal Bid, RFP, SOQ or any contracts, contract amendments, renewals or change orders are required to complete the Form 1295 online through the State of Texas Ethics Commission website. Please visit: https://www.ethics.state.tx.us/whatsnew/elf_info_form1295.htm.
- 5.2 On-line instructions:
 - 5.2.1 Name of governmental entity is to read: Fort Bend County.
 - 5.2.2 Identification number used by the governmental entity is: B21-048.
 - 5.2.3 Description is the title of the solicitation: Traffic Signs, Posts, Supplies.
- 5.3 Apparent low bidder(s) will be required to provide the Form 1295 within three (3) calendar days from notification; however, if your company is publicly traded you are not required to complete this form.

6.0 STATE LAW REQUIREMENTS FOR CONTRACTS:

The contents of this section are required by Texas Law and are included by County regardless of content.

- 6.1 Agreement to Not Boycott Israel Chapter 2270 Texas Government Code: By signature on vendor form, Contractor verifies Contractor does not boycott Israel and will not boycott Israel during the term of this Contract.
- 6.2 Texas Government Code Section 2251.152 Acknowledgment: By signature on vendor form, Contractor represents pursuant to Section 2252.152 of the Texas Government Code, that Contractor is not listed on the website of the Comptroller of the State of Texas concerning the listing of companies that are identified under Section 806.051, Section 807.051 or Section 2253.153.

7.0 HUMAN TRAFFICKING:

By acceptance of this contract, Contractor acknowledges that Fort Bend County is opposed to human trafficking and that no County funds will be used in support of services or activities that violate human trafficking laws.



8.0 ASSIGNMENT:

Contractor shall not sell, assign, transfer or convey these services, in whole or in part, without the prior written consent of Fort Bend County and as a condition of such consent, contractor shall remain liable for completion of the services in the event of default by the successor contractor or assignee.

9.0 AWARD:

This contract will be awarded to the lowest and best bidder per section.

10.0 GENERAL:

- 10.1 Quantities listed are estimates only. Fort Bend County does not guarantee the quantities stated will be purchased.
- 10.2 No minimum orders, by quantity or dollar amount.
- 10.3 Bidders may be required to submit samples for inspection and evaluation after bid opening to determine acceptability.

11.0 DELIVERY:

- 11.1 Vendor must complete delivery within thirty (30) working days after receipt of purchase order.
- 11.2 The successful bidder shall not deliver products without a Purchase Order issued by the Fort Bend County Purchasing Agent.
- 11.3 The successful bidder shall not deliver products or services in excess of those authorized and under no circumstances will Fort Bend County be liable for payment of products or services, which exceed the amounts authorized by the purchase order.
- 11.4 All orders must be delivered between 8:00 AM and 3:00 PM, Monday through Friday to the address indicated on purchase order.

12.0 SPECIFICATIONS and BID PRICING:

Specifications are located in the Excel pricing form downloadable from Fort Bend County's website. Provide bid prices in the electronic Excel file and return as stated in Section 1.4 and 1.5.

13.0 QUALITY CONTROL:

Fort Bend County reserves the right to sample and test products at time of delivery for specification compliance in the presence of the driver or vendor's representative. Costs for tests shall be borne by the Contractor in the event product fails to meet specifications. Products not in their original

Initials of Bidder:



package will not be accepted.

14.0 REQUIRED FORMS:

All vendors submitting are required to complete and provide with submission:

- 14.1 Electronic Excel file of Pricing Form on CD or flash drive and printed hard copy
- 14.2 Vendor Form
- 14.3 W9 Form
- 14.4 Tax Form/Debt/Residence Certification

Initials of Bidder: _____



Contract Sheet
Bid 21-048

THE STATE OF TEXAS
COUNTY OF FORT BEND



This memorandum of agreement made and entered into on the 23rd day of March, 2021,
by and between Fort Bend County in the State of Texas (hereinafter designated County), acting herein by
County Judge KP George, by virtue of an order of Fort Bend County Commissioners Court, and
Core Products LLC (hereinafter designated Contractor).
(company name)

WITNESSETH:

The Contractor and the County agree that the bid and specifications for the **Purchase of Oil and Lubricants** which are hereto attached and made a part hereof, together with this instrument and the bond (when required) shall constitute the full agreement and contract between parties and for furnishing the items set out and described; the County agrees to pay the prices stipulated in the accepted bid.

It is further agreed that this contract shall not become binding or effective until signed by the parties hereto and a purchase order authorizing the items desired has been issued.

Executed at Richmond, Texas this 23 day of March 2021.

County Judge KP George
Fort Bend County, Texas
By: _____
County Judge, KP George
By: 
Signature of Contractor
By: Chris McDonald - Sales Manager
Printed Name and Title

COUNTY PURCHASING AGENT

Fort Bend County, Texas



Jaime Kovar
County Purchasing Agent

(281) 341-8640
Fax (281) 341-8645

January 4, 2021

TO: All Prospective Bidders

RE: Addendum No. 1 – Fort Bend County Bid 21-048 – Traffic Signs, Posts & Supplies

Addendum 1:

Attached is addendum 1. Vendors are to use Addendum 1 document while preparing their solicitation response. Contract name updated on Contract Sheet, page 17.

Immediately upon your receipt of this addendum, please fill out the following information and email this page to Jessica Carabajal at jessica.carabajal@fortbendcountytexas.gov

Core Products LLC

Company Name

[Signature] 1/13/2021

Signature of person receiving addendum Date

If you have any questions, please contact this office.

Sincerely,

[Signature]

Cheryl Krejci
Senior Buyer

Request for Taxpayer Identification Number and Certification

**Give Form to the
requester. Do not
send to the IRS.**

▶ Go to www.irs.gov/FormW9 for instructions and the latest information.

Print or type. See Specific Instructions on page 3.	1 Name (as shown on your income tax return). Name is required on this line; do not leave this line blank. Core Products, LLC		
	2 Business name/disregarded entity name, if different from above		
	3 Check appropriate box for federal tax classification of the person whose name is entered on line 1. Check only one of the following seven boxes.		4 Exemptions (codes apply only to certain entities, not individuals; see instructions on page 3): Exempt payee code (if any) _____ Exemption from FATCA reporting code (if any) _____ <i>(Applies to accounts maintained outside the U.S.)</i>
	<input type="checkbox"/> Individual/sole proprietor or single-member LLC <input type="checkbox"/> C Corporation <input type="checkbox"/> S Corporation <input type="checkbox"/> Partnership <input type="checkbox"/> Trust/estate <input checked="" type="checkbox"/> Limited liability company. Enter the tax classification (C=C corporation, S=S corporation, P=Partnership) ▶ <u> S </u> Note: Check the appropriate box in the line above for the tax classification of the single-member owner. Do not check LLC if the LLC is classified as a single-member LLC that is disregarded from the owner unless the owner of the LLC is another LLC that is not disregarded from the owner for U.S. federal tax purposes. Otherwise, a single-member LLC that is disregarded from the owner should check the appropriate box for the tax classification of its owner. <input type="checkbox"/> Other (see instructions) ▶		
	5 Address (number, street, and apt. or suite no.) See instructions. PO Box 5137		Requester's name and address (optional)
	6 City, state, and ZIP code Covington, LA 70434		
	7 List account number(s) here (optional)		

Part I Taxpayer Identification Number (TIN)

Enter your TIN in the appropriate box. The TIN provided must match the name given on line 1 to avoid backup withholding. For individuals, this is generally your social security number (SSN). However, for a resident alien, sole proprietor, or disregarded entity, see the instructions for Part I, later. For other entities, it is your employer identification number (EIN). If you do not have a number, see *How to get a TIN*, later.

Note: If the account is in more than one name, see the instructions for line 1. Also see *What Name and Number To Give the Requester* for guidelines on whose number to enter.

Social security number									
				-			-		
or									
Employer identification number									
4	7	-	5	1	5	2	3	1	6

Part II Certification

Under penalties of perjury, I certify that:

- The number shown on this form is my correct taxpayer identification number (or I am waiting for a number to be issued to me); and
- I am not subject to backup withholding because: (a) I am exempt from backup withholding, or (b) I have not been notified by the Internal Revenue Service (IRS) that I am subject to backup withholding as a result of a failure to report all interest or dividends, or (c) the IRS has notified me that I am no longer subject to backup withholding; and
- I am a U.S. citizen or other U.S. person (defined below); and
- The FATCA code(s) entered on this form (if any) indicating that I am exempt from FATCA reporting is correct.

Certification instructions. You must cross out item 2 above if you have been notified by the IRS that you are currently subject to backup withholding because you have failed to report all interest and dividends on your tax return. For real estate transactions, item 2 does not apply. For mortgage interest paid, acquisition or abandonment of secured property, cancellation of debt, contributions to an individual retirement arrangement (IRA), and generally, payments other than interest and dividends, you are not required to sign the certification, but you must provide your correct TIN. See the instructions for Part II, later.

Sign Here	Signature of U.S. person ▶ <i>Cathy Warren</i>	Date ▶ <i>1/4/2021</i>
------------------	--	------------------------

General Instructions

Section references are to the Internal Revenue Code unless otherwise noted.

Future developments. For the latest information about developments related to Form W-9 and its instructions, such as legislation enacted after they were published, go to www.irs.gov/FormW9.

Purpose of Form

An individual or entity (Form W-9 requester) who is required to file an information return with the IRS must obtain your correct taxpayer identification number (TIN) which may be your social security number (SSN), individual taxpayer identification number (ITIN), adoption taxpayer identification number (ATIN), or employer identification number (EIN), to report on an information return the amount paid to you, or other amount reportable on an information return. Examples of information returns include, but are not limited to, the following.

- Form 1099-INT (interest earned or paid)

- Form 1099-DIV (dividends, including those from stocks or mutual funds)
- Form 1099-MISC (various types of income, prizes, awards, or gross proceeds)
- Form 1099-B (stock or mutual fund sales and certain other transactions by brokers)
- Form 1099-S (proceeds from real estate transactions)
- Form 1099-K (merchant card and third party network transactions)
- Form 1098 (home mortgage interest), 1098-E (student loan interest), 1098-T (tuition)
- Form 1099-C (canceled debt)
- Form 1099-A (acquisition or abandonment of secured property)

Use Form W-9 only if you are a U.S. person (including a resident alien), to provide your correct TIN.

If you do not return Form W-9 to the requester with a TIN, you might be subject to backup withholding. See What is backup withholding, later.

Job No.: Bid #21-048

TAX FORM/DEBT/ RESIDENCE CERTIFICATION
(for Advertised Projects)

Taxpayer Identification Number (T.I.N.): 47-5152316

Company Name submitting Bid/Proposal: Core Products LLC

Mailing Address: PO Box 5137, Covington, LA 70434

Are you registered to do business in the State of Texas? Yes No

If you are an individual, list the names and addresses of any partnership of which you are a general partner or any assumed name(s) under which you operate your business

I. **Property:** List all taxable property in Fort Bend County owned by you or above partnerships as well as any d/b/a names. Include real and personal property as well as mineral interest accounts. (Use a second sheet of paper if necessary.)

Fort Bend County Tax Acct. No.*	Property address or location**
_____	_____
_____	_____
_____	_____
_____	_____

* This is the property account identification number assigned by the Fort Bend County Appraisal District.

** For real property, specify the property address or legal description. For business personal property, specify the address where the property is located. For example, office equipment will normally be at your office, but inventory may be stored at a warehouse or other location.

II. **Fort Bend County Debt** - Do you owe any debts to Fort Bend County (taxes on properties listed in I above, tickets, fines, tolls, court judgments, etc.)?

Yes No If yes, attach a separate page explaining the debt.

III. **Residence Certification** - Pursuant to Texas Government Code §2252.001 *et seq.*, as amended, Fort Bend County requests Residence Certification. §2252.001 *et seq.* of the Government Code provides some restrictions on the awarding of governmental contracts; pertinent provisions of §2252.001 are stated below:

(3) "Nonresident bidder" refers to a person who is not a resident.

(4) "Resident bidder" refers to a person whose principal place of business is in this state, including a contractor whose ultimate parent company or majority owner has its principal place of business in this state.

I certify that _____ is a Resident Bidder of Texas as defined in Government Code §2252.001.
[Company Name]

I certify that Core Products LLC is a Nonresident Bidder as defined in Government Code §2252.001 and our principal place of business is Covington, LA 70434.
[Company Name] [City and State]

Fort Bend County Pricing Form
BID 21-048
Term Contract for Traffic Signs, Posts and Supplies

Vendor Name: Core Products, LLC

Section 1: Complete Signs Finished traffic signs must be .080 aluminum with faces, diamond grade, VIP, reflective sheeting. Add 3M protective overlay film (series 1160) to each sign.	Estimated Annual Quantity	Bid Price per Each	Extended Cost
All way, 18 x 6, red white VIP diamond Grade (MUTCD R1-4)	400		\$ -
Watch for ice on bridge, 36 x 36, hinged with closure hook, fluorescent yellow, diamond grade material	100		\$ -
Type III, 12x36, fluorescent yellow, DG3, (MUTCD OM-3R)	50		\$ -
Type III, 12x36, fluorescent yellow, DG3, (MUTCD OM-3L)	50		\$ -
Total Section 1:			\$ -

Vendor Name: Core Products, LLC

Section 2: Blanks Blanks must be .080 aluminum	Estimated Annual Quantity	Bid Price per Each	Extended Cost
Blanks, rounded corners, diamond punch 18 x 18	1000		\$ -
Blanks, rounded corners, diamond punch 24 x 24	1000		\$ -
Blanks, rounded corners, diamond punch 30 x 30	1000		\$ -
Blanks, rounded corners, diamond punch 36 x 36	500		\$ -
Blanks, octagon 30 x 30	1000		\$ -
Blanks, octagon 36 x 36	300		\$ -
Blanks, pentagon 30 x 30	300		\$ -
Blanks, pentagon 36 x 36	65		\$ -
Blanks, rounded corners, rectangle 24 x 8	400		\$ -
Blanks, rounded corners, rectangle 24 x 10	400		\$ -
Blanks, rounded corners, rectangle 24 x 12	400		\$ -
Blanks, rounded corners, rectangle 12 x 18	400		\$ -
Blanks, rounded corners, rectangle 18 x 24	400		\$ -
Blanks, rounded corners, rectangle 24 x 30	1000		\$ -
Blanks, rounded corners, rectangle 24 x 36	300		\$ -
Blanks, rounded corners, rectangle 30 x 36	100		\$ -
Blanks, rounded corners, rectangle 24 x 48	500		\$ -
Blanks, rounded corners, rectangle 30 x 48	100		\$ -
Blanks, rounded corners, rectangle 36 x 18	500		\$ -
Blanks, rounded corners, square 18 x 18	1000		\$ -
Blanks, rounded corners, square 24 x 24	1000		\$ -
Blanks, rounded corners, street sign, flat, 9 x 30	600		\$ -
Blanks, rounded corners, street sign, flat, 9 x 36	600		\$ -
Blanks, rounded corners, street sign, flat, 9 x 42	600		\$ -
Blanks, rounded corners, street sign, flat, 9 x 48	600		\$ -
Blanks, round, 36" diameter	300		\$ -
Blanks, rounded corners, rectangle, 10 x 30	300		\$ -
Blanks, rounded corners, rectangle, 12 x 30	300		\$ -
Blanks, rounded corners, triangle, 30	500		\$ -
Blanks, rounded corners, triangle, 36	500		\$ -
Blanks, extruded, 9 x 30	1000		\$ -
Blanks, extruded, 9 x 36	1000		\$ -
Blanks, extruded, 9 x 42	1000		\$ -
Blanks, extruded, 9 x 48	1000		\$ -
Blanks, extruded, 9 x 54	1000		\$ -
Total Section 2:			\$ -

Vendor Name: Core Products, LLC

Section 3: Posts and Accessories-Telespar Sign Support System	Estimated Annual Quantity	Bid Price per Each	Extended Cost
12' Round 2.375 16 gauge galvanized post	500		\$ -
14' 1-3/4"x1-3/4" square 12 gauge galvanized sign post	500		\$ -
12" round post cap flat blade for 2.375" round post	500		\$ -
12" round post cap extruded for 2.375" round post	500		\$ -
**74-5606 TRF RD RW 2.375 16 gauge Post, 12'	500		\$ -
75-4892 TRF RD Taper 2.875 Poz Loc Sockets	500		\$ -
76-6050 6603 RD Post Shim W/9/16" Hole Wedges	500		\$ -
Square sign post, 12 ft., 12 gauge, galvanized steel, pre-punched, 1-3/4" x 1-3/4"	1500		\$ -
U channel galvanized steel post 7 ft. 1.12 lbs.	1500		\$ -
Square post caps, 5-1/2" blade, flat with set screws	1500		\$ -
Square post caps, 5-1/2" blade, extruded with set screws	1500		\$ -
Round post caps for flat with set screws, 2-3/8" post OD for 5-1/2" blade	500		\$ -
Round post caps for extruded with set screws, 2-3/8" post OD for 5-1/2" blade	500		\$ -
Small corner bolts	4500		\$ -
Flanged nuts	4500		\$ -
Anchors: 1-7/8" x 1-7/8" x 36"	5000		\$ -
Drive Rivets, 3/8" aluminum	20000		\$ -
Cross brackets for street signs, 5-1/2" blade holder with set screws for flat	1000		\$ -
Cross brackets for street signs, 5-1/2" blade holder with set screws for extruded	1000		\$ -
Cross brackets for street signs, 12" blade holder with set screws for flat	1000		\$ -
Cross brackets for street signs, 12" blade holder with set screws for extruded	1000		\$ -
2-7/8" OD, rounded, for flat blades, 5-1/2" blade holder with set screws	1000		\$ -
2-3/8" OD, round 12" post caps for flat blade with set screws	1000		\$ -
2-3/8" OD, round 12" post caps for extruded with set screws	1000		\$ -
12" blade for flat street signs, square post cap, 1-3/4"	1000		\$ -
12" blade for extruded street signs, square post cap, 1-3/4"	1000		\$ -
2-3/8" post clamp with fasteners included with each clamp, aluminum	1000		\$ -
Total Section 3:			\$ -

Vendor Name: Core Products, LLC

Section 4: Construction Supplies	Estimated Annual Quantity	Bid Price per Each	Extended Cost
Barricade, portable type I standard 36" plastic with reflective DG3 diamond grade sheeting with aluminum	200		\$ -
Barricade, Type III collapsible, diamond grade reflective sheeting, no-maintenance plastic boards, 8 foot, double sided sheeting right and left with Telespar tubing for upright support and legs, 1" thick x 8" tall board	100		\$ -
Barricade, Type III collapsible, diamond grade reflective sheeting, no-maintenance plastic boards, 10 foot, double sided sheeting right and left with Telespar tubing for upright support and legs, 1" thick x 8" tall board	100		\$ -
Barricade, Type III collapsible, diamond grade reflective sheeting, no-maintenance plastic boards, 12 foot, double sided sheeting right and left with Telespar tubing for upright support and legs, 1" thick x 8" tall board	100		\$ -
End of Road barricade boards, Type III with DG3 diamond grade sheeting on no-maintenance plastic boards, 10', red and white, 1" thick x 8" tall board, 3 right boards	100		\$ -
End of Road barricade boards, Type III with DG3 diamond grade sheeting on no-maintenance plastic boards, 10', red and white, 1" thick x 8" tall board, 3 left boards	100		\$ -
Barricade, two (2) "A" frames with two (2) 10' diamond grade sheeted I-beams, molded no-maintenance plastic boards, orange and white, right on one side and left on other side	100		\$ -
Safety cones, 28", orange, 12# weight, 4" upper reflective collars, with white diamond grade VIP reflective sheeting, 14-3/4" x 14-3/4" base	100		\$ -
Safety cones, 28", orange, 12# weight, 6" upper reflective collars, with white diamond grade VIP reflective sheeting, 14-3/4" x 14-3/4" base	100		\$ -
Safety cones, 36", orange, 12# weight, 4" upper reflective collars, with white diamond grade VIP reflective sheeting, 14-3/4" x 14-3/4" base	100		\$ -
Safety cones, 36", orange, 12# weight, 6" upper reflective collars, with white diamond grade VIP reflective sheeting, 14-3/4" x 14-3/4" base	100		\$ -

Vendor Name: Core Products, LLC

Section 4: Construction Supplies (cont'd)	Estimated Annual Quantity	Bid Price per each	Extended Cost
Vertical Panel with 20" x 28" black rubber rectangular base, reflective panel 8" x 36", orange and white diagonal sheeting, double sided, diamond grade reflective sheeting,	300		\$ -
Warning light, Colt RS-600, 6 volt type A	200		\$ -
Warning light spring battery, general purpose 6 volt type	200		\$ -
Delineator reflectors, 4" x 4", white aluminum with diamond grade sheeting	2000		\$ -
Delineator reflectors, 4" x 4", fluorescent yellow aluminum with diamond grade sheeting	2000		\$ -
Standard roll up construction signs, 48 x 48 reflective, vinyl, plastic corner pockets with ribs with overlays, fluorescent orange. All construction signs in the Texas Manual on Uniform Traffic Control with carrying bags	100		\$ -
Standard roll up construction signs, 36 x 36 reflective, vinyl, plastic corner pockets with ribs with overlays, fluorescent orange. All construction signs in the Texas Manual on Uniform Traffic Control with carrying bags	50		\$ -
DF3000W 12" Screwlock Roll-Up Sign Stand	15		\$ -
DF3003W 12" Screwlock Roll-Up Sign Stand	15		\$ -
DF3000S 12" Stablock Fold & Roll Sign Stand	15		\$ -
DF3003S 12" Stablock Fold & Roll Sign Stand	15		\$ -
DF4503 5" RUB3315 Roll-Up Sign Stand	15		\$ -
DF4700TX 7" RUB3315 Roll-Up Sign Stand	15		\$ -
Chip seal markers, white with cover, two sided	5000		\$ -
Chip seal markers, yellow with cover, two sided	5000		\$ -
Total Section 4:			\$ -

Section 5: Carsonite Products or equal (See Section 1.18 Name Brands)	Estimated Annual Quantity	Bid Price per Each	Extended Cost
Road markers, white, Carsonite CRM-375., flexible 3.75" width x 62" length, with 3" x 12" fluorescent yellow reflective diamond grade VIP installed	1500		\$ -
Total Section 5:			\$ -

Vendor Name: Core Products, LLC

Section 6: 3M Products	Estimated Annual Quantity	Bid Price per Each	Extended Cost
Rolls, 30", red, reflective series DG3 cubed, pressure sensitive	20		\$ -
Rolls, 30" x 50 yd., white, engineer grade, pressure sensitive, #3200T	10		\$ -
Rolls, 36" x 50 yd., white, engineer grade, pressure sensitive, #3200T	10		\$ -
Rolls, 9", white, reflective, series DG3 cubed, pressure sensitive	20		\$ -
Rolls, 24", white, reflective, series DG3 cubed, pressure sensitive	20		\$ -
Rolls, 30", white, reflective series DG3 cubed, pressure sensitive	20		\$ -
Rolls, 36", white, reflective series DG3 cubed, pressure sensitive	20		\$ -
Rolls, 9", yellow, reflective, engineer grade, pressure sensitive, #3200T	5		\$ -
Rolls, 9", yellow, reflective, series DG3 cubed, pressure sensitive	5		\$ -
Rolls, 18", yellow, reflective, series DG3 cubed, pressure sensitive	10		\$ -
Rolls, 24", yellow, reflective, series DG3 cubed, pressure sensitive	10		\$ -
Rolls, 30", yellow, reflective, series DG3 cubed, pressure sensitive	10		\$ -
Rolls, 36", yellow, reflective, series DG3 cubed, pressure sensitive	5		\$ -
Rolls, 9", fluorescent yellow, reflective, series DG3 cubed, pressure sensitive	5		\$ -
Rolls, 18", fluorescent yellow, reflective, series DG3 cubed, pressure sensitive	5		\$ -
Rolls, 24", fluorescent yellow, reflective, series DG3 cubed, pressure sensitive	5		\$ -
Rolls, 30", fluorescent yellow, reflective, series DG3 cubed, pressure sensitive	5		\$ -
Rolls, 36", fluorescent yellow, reflective, series DG3 cubed, pressure sensitive	5		\$ -
Rolls, 24", fluorescent yellow green, reflective, series DG3 cubed, pressure sensitive	5		\$ -
Rolls, 30", fluorescent yellow green, reflective, series DG3 cubed, pressure sensitive	5		\$ -

Vendor Name: Core Products, LLC

Section 6: 3M Products (cont'd)	Estimated Annual Quantity	Bid Price per Each	Extended Cost
Rolls, 18", fluorescent orange, reflective, series DG3 cubed, pressure sensitive	6		\$ -
Rolls, 30", fluorescent orange, reflective, series DG3 cubed, pressure sensitive	6		\$ -
Rolls, 36", fluorescent orange, reflective, series DG3 cubed, pressure sensitive	6		\$ -
Rolls, 18", black, non-reflective, vinyl, clear synthetic	5		\$ -
Rolls, 24", black, non-reflective, vinyl, clear synthetic	5		\$ -
Rolls, 30", black, non-reflective, vinyl, clear synthetic	5		\$ -
Rolls, 36", black, non-reflective, vinyl, clear synthetic	5		\$ -
Rolls, 30", white, non-reflective, vinyl, clear synthetic	10		\$ -
Rolls, 9", transfer tape, clear	60		\$ -
Rolls, 12", transfer tape, clear	60		\$ -
Rolls, 24", transfer tape, clear TPM5 transfer	50		\$ -
Rolls, 30", transfer tape, clear TPM5	50		\$ -
Rolls, 36", transfer tape, clear TPM5	50		\$ -
24", E C film, brown, clear synthetic liner	6		\$ -
30", E C film, brown, clear synthetic liner	6		\$ -
24", E C film, green, clear synthetic liner	20		\$ -
30", E C film, green, clear synthetic liner	6		\$ -
24", E C film, blue, clear synthetic liner	6		\$ -
30", E C film, blue, clear synthetic liner	6		\$ -
24", E C film, red, clear synthetic liner	6		\$ -
30", E C film, red, clear synthetic liner	6		\$ -
36", E C film, red, clear synthetic liner	6		\$ -
2" roll, red/white, conspicuity marking, series DG3 cubed, pressure sensitive, red/white block, 6" x 6", 983-32	6		\$ -

Vendor Name: Core Products, LLC

Section 6: 3M Products (cont'd)	Estimated Annual Quantity	Bid Price per Each	Extended Cost
Faces (Faces only NOT complete signs, Does Not include blank) Faces must be pressure sensitive, series DG3 cubed, reflective sheeting and packaged with slip sheeting. Must be packaged with plastic washers.			
Faces: Stop ahead (symbol), 30" fluorescent yellow, series DG3 cubed, material Symbol MUTCD W3-1A	300		\$ -
Faces: Stop ahead (symbol), 36" fluorescent yellow, series DG3 cubed, material Symbol MUTCD W3-1A	300		\$ -
Faces: Stop sign, 30 x 30, series DG3 cubed, pre-cut corners	1000		\$ -
Faces: Stop sign, 36 x 36, series DG3 cubed, pre-cut corners	300		\$ -
Faces: Yield, 30 x 30	300		\$ -
Faces: Signals ahead, 30 x 30 fluorescent yellow, series DG3 cubed, Symbol MUTCD W3-3	300		\$ -
Faces: White body raised pavement markings, one-way white lens, 100 per carton	10		\$ -
Faces: White body raised pavement markings, two-way white lens, 100 per carton	10		\$ -
Faces: White body raised pavement markings, two-way white/red lens, 100 per carton	10		\$ -
Faces: Yellow body raised pavement markings, one-way yellow lens, 100 per carton	10		\$ -
Faces: Yellow body raised pavement markings, two-way yellow lens, 100 per carton	10		\$ -
Faces: One way pressure sensitive adhesive raised pavement markers white lens, 100 per carton	10		\$ -
Faces: One way pressure sensitive adhesive raised pavement markers yellow lens, 100 per carton	10		\$ -
Faces: One way pressure sensitive adhesive raised pavement markers red lens, 100 per carton	10		\$ -
Faces: Two way pressure sensitive adhesive raised pavement markers white lens, 100 per carton	10		\$ -
Faces: Two way pressure sensitive adhesive raised pavement markers yellow lens, 100 per carton	10		\$ -
3M protective overlay film (series 1160), 30" x 50 yards per roll	10		\$ -
3M protective overlay film (series 1160), 36" x 50 yards per roll	10		\$ -
3M citrus base cleaner (aerosol)	100		\$ -

Vendor Name: Core Products, LLC

Section 6: 3M Products (cont'd)	Estimated Annual Quantity	Bid Price per Each	Extended Cost
Faces (Faces only NOT complete signs, Does Not include blank) Faces must be pressure sensitive, series DG3 cubed, reflective sheeting and packaged with slip sheeting. Must be packaged with plastic washers. Add 3M protective overlay film (series 1160) to each sign face.			
Faces: Stop ahead (symbol), 30" fluorescent yellow, series DG3 cubed, material Symbol MUTCD W3-1A	1000		\$ -
Faces: Stop ahead (symbol), 36" fluorescent yellow, series DG3 cubed, material Symbol MUTCD W3-1A	1000		\$ -
Faces: Stop sign, 30 x 30, series DG3 cubed, pre-cut corners	1000		\$ -
Faces: Stop sign, 36 x 36, series DG3 cubed, pre-cut corners	1000		\$ -
Faces: Yield, 30 x 30	1000		\$ -
Faces: Yield, 36 x 36	500		\$ -
Faces: Signals ahead, 30 x 30 fluorescent yellow, series DG3 cubed, Symbol MUTCD W3-3	1000		\$ -
Faces: White body raised pavement markings, one-way white lens, 100 per carton	10		\$ -
Faces: White body raised pavement markings, two-way white lens, 100 per carton	10		\$ -
Faces: White body raised pavement markings, two-way white/red lens, 100 per carton	10		\$ -
Faces: Yellow body raised pavement markings, one-way yellow lens, 100 per carton	10		\$ -
Faces: Yellow body raised pavement markings, two-way yellow lens, 100 per carton	10		\$ -
Faces: One way pressure sensitive adhesive raised pavement markers white lens, 100 per carton	10		\$ -
Faces: One way pressure sensitive adhesive raised pavement markers yellow lens, 100 per carton	10		\$ -
Faces: One way pressure sensitive adhesive raised pavement markers red lens, 100 per carton	10		\$ -
Faces: Two way pressure sensitive adhesive raised pavement markers white lens, 100 per carton	10		\$ -
Faces: Two way pressure sensitive adhesive raised pavement markers yellow lens, 100 per carton	10		\$ -
Total Section 6:			\$ -

Vendor Name: Core Products, LLC

Section 7: Avery Denison	Estimated Annual Quantity	Bid Price per Each	Extended Cost
Rolls, 30" x 50 yd., white, engineer grade, pressure sensitive, #3200T	10		\$ -
Rolls, 36" x 50 yd., white, engineer grade, pressure sensitive, #3200T	10		\$ -
Rolls, 9", white, reflective, series DG3 cubed, pressure sensitive	20		\$ -
Rolls, 24", white, reflective, series DG3 cubed, pressure sensitive	20		\$ -
Rolls, 30", white, reflective, series DG3 cubed, pressure sensitive	20		\$ -
Rolls, 36", white, reflective, series DG3 cubed, pressure sensitive	20		\$ -
Rolls, 9", yellow, reflective, engineer grade, pressure sensitive, #3200T	5		\$ -
Rolls, 9", yellow, reflective, series DG3 cubed, pressure sensitive	5		\$ -
Rolls, 18", yellow, reflective, series DG3 cubed, pressure Sensitive	10		\$ -
Rolls, 24", yellow, reflective, series DG3 cubed, pressure Sensitive	10		\$ -
Rolls, 30", yellow, reflective, series DG3 cubed, pressure Sensitive	10		\$ -
Rolls, 36", yellow, reflective, series DG3 cubed, pressure Sensitive	10		\$ -
Rolls, 9", fluorescent yellow, reflective, series DG3 cubed, pressure sensitive	10		\$ -
Rolls, 18", fluorescent yellow, reflective, series DG3 cubed, pressure sensitive	10		\$ -
Rolls, 24", fluorescent yellow, reflective, series DG3 cubed, pressure sensitive	10		\$ -
Rolls, 30", fluorescent yellow, reflective, series DG3 cubed, pressure sensitive	10		\$ -
Rolls, 36", fluorescent yellow, reflective, series DG3 cubed, pressure sensitive	10		\$ -
Rolls, 24", fluorescent yellow green, reflective, series DG3 cubed, pressure sensitive	10		\$ -
Rolls, 30", fluorescent yellow green, reflective, series DG3 cubed, pressure sensitive	10		\$ -
Rolls, 18", fluorescent orange, reflective, series DG3 cubed, pressure sensitive	10		\$ -
Rolls, 30", fluorescent orange, reflective, series DG3 cubed, pressure sensitive	10		\$ -

Vendor Name: Core Products, LLC

Section 7: Avery Denison (cont'd)	Estimated Annual Quantity	Bid Price per Each	Extended Cost
Rolls, 36", fluorescent orange, reflective, series DG3 cubed, pressure sensitive	10		\$ -
Rolls, 18", black, non-reflective, vinyl, clear synthetic	10		\$ -
Rolls, 24", black, non-reflective, vinyl, clear synthetic	10		\$ -
Rolls, 30", black, non-reflective, vinyl, clear synthetic	10		\$ -
Rolls, 36", black, non-reflective, vinyl, clear synthetic	10		\$ -
Rolls, 30", white, non-reflective, vinyl, clear synthetic	10		\$ -
Rolls, 9", transfer tape, clear	60		\$ -
Rolls, 12", transfer tape, clear	60		\$ -
24", E C film, brown, clear synthetic liner	6		\$ -
30", E C film, brown, clear synthetic liner	6		\$ -
24", E C film, green, clear synthetic liner	6		\$ -
30", E C film, green, clear synthetic liner	6		\$ -
24", E C film, blue, clear synthetic liner	6		\$ -
30", E C film, blue, clear synthetic liner	6		\$ -
24", E C film, red, clear synthetic liner	6		\$ -
30", E C film, red, clear synthetic liner	6		\$ -
36", E C film, red, clear synthetic liner	6		\$ -
2" roll, red/white, conspicuity marking, series DG3 cubed, pressure sensitive, red/white block, 6" x 6", 983-32	6		\$ -

Vendor Name: Core Products, LLC

Section 7: Avery Denison (cont'd)	Estimated Annual Quantity	Bid Price per Each	Extended Cost
Faces (Faces only NOT complete signs, Does Not include blank) Faces must be pressure sensitive, series DG3 cubed, reflective sheeting and packaged with slip sheeting. Must be packaged with plastic washers.			
Faces: Stop ahead (symbol), 30" fluorescent yellow, series DG3 cubed, material Symbol MUTCD W3-1A	300		\$ -
Faces: Stop sign, 30 x 30, series DG3 cubed, pre-cut corners	1000		\$ -
Faces: Stop sign, 36 x 36, series DG3 cubed, pre-cut corners	300		\$ -
Faces: Yield, 30 x 30	300		\$ -
Faces: Signals ahead, 30 x 30 fluorescent yellow, series DG3 cubed, Symbol MUTCD W3-3	300		\$ -
Faces: White body raised pavement markings, one-way white lens, 100 per carton	10		\$ -
Faces: White body raised pavement markings, two-way white lens, 100 per carton	10		\$ -
Faces: White body raised pavement markings, two-way white/red lens, 100 per carton	10		\$ -
Faces: Yellow body raised pavement markings, one-way yellow lens, 100 per carton	10		\$ -
Faces: Yellow body raised pavement markings, two-way yellow lens, 100 per carton	10		\$ -
Faces: One way pressure sensitive adhesive raised pavement markers white lens, 100 per carton	10		\$ -
Faces: One way pressure sensitive adhesive raised pavement markers yellow lens, 100 per carton	10		\$ -
Faces: One way pressure sensitive adhesive raised pavement markers red lens, 100 per carton	10		\$ -
Faces: Two way pressure sensitive adhesive raised pavement markers white lens, 100 per carton	10		\$ -
Faces: Two way pressure sensitive adhesive raised pavement markers yellow lens, 100 per carton	10		\$ -
Protective overlay film (series 1160), 30" x 50 yards	10		\$ -
Protective overlay film (series 1160), 36" x 50 yards	10		\$ -
Total Section 7:			\$ -

Vendor Name: Core Products, LLC

Section 8: Cutting Knives	Estimated Annual Quantity	Bid Price per Each	Extended Cost
CB09UA-5 cutting knives for Western Graphtec cutting pro 300-100	25		\$ -
CB15U-5 cutting knives for Western Graphtec cutting pro 300-100	25		\$ -
Total Section 8:			\$ -

Section 9: Banding Materials	Estimated Annual Quantity	Bid Price per Each	Extended Cost
Stainless steel, 3/4" x 100' x .030 coil in dispensing box, type 201 universal	3	\$41.25	\$ 123.75
3/4" wide stainless steel top split wing seal	100	\$0.22	\$ 22.00
Flared leg stainless sign bracket with bolt & washer	100	\$1.40	\$ 140.00
Total Section 9:			\$ 285.75

Vendor Name: Core Products, LLC

Section 10: Safety Vests	Estimated Annual Quantity	Bid Price per Each	Extended Cost
Safetey vests, ML Kishigo Ultra-Cool mesh, contrasting #1056 (or equal), ANSI/ISEA 107 2010 Class 2 compliant, zipper front closure, 2" wide reflective material with 4.5" contrasting color, inside left chest 2-tier 4-division pencil pocket, lower right inside patch pocket, with Mic Tab on front left chest, with Road and Bridge imprinted on back, Size: M	100		\$ -
Safetey vests, ML Kishigo Ultra-Cool mesh, contrasting #1056 (or equal), ANSI/ISEA 107 2010 Class 2 compliant, zipper front closure, 2" wide reflective material with 4.5" contrasting color, inside left chest 2-tier 4-division pencil pocket, lower right inside patch pocket, with Mic Tab on front left chest, with Road and Bridge imprinted on back, Size: L	100		\$ -
Safetey vests, ML Kishigo Ultra-Cool mesh, contrasting #1056 (or equal), ANSI/ISEA 107 2010 Class 2 compliant, zipper front closure, 2" wide reflective material with 4.5" contrasting color, inside left chest 2-tier 4-division pencil pocket, lower right inside patch pocket, with Mic Tab on front left chest, with Road and Bridge imprinted on back, Size: XL	100		\$ -
Safetey vests, ML Kishigo Ultra-Cool mesh, contrasting #1056 (or equal), ANSI/ISEA 107 2010 Class 2 compliant, zipper front closure, 2" wide reflective material with 4.5" contrasting color, inside left chest 2-tier 4-division pencil pocket, lower right inside patch pocket, with Mic Tab on front left chest, with Road and Bridge imprinted on back, Size: XXL	100		\$ -
Safetey vests, ML Kishigo Ultra-Cool mesh, contrasting #1056 (or equal), ANSI/ISEA 107 2010 Class 2 compliant, zipper front closure, 2" wide reflective material with 4.5" contrasting color, inside left chest 2-tier 4-division pencil pocket, lower right inside patch pocket, with Mic Tab on front left chest, with Road and Bridge imprinted on back, Size: XXXL	100		\$ -

Vendor Name: Core Products, LLC

Section 10: Safety Vests (cont'd)	Estimated Annual Quantity	Bid Price per Each	Extended Cost
Safetey vests, ML Kishigo Ultra-Cool mesh, contrasting #1056 (or equal), ANSI/ISEA 107 2010 Class 2 compliant, zipper front closure, 2" wide reflective material with 4.5" contrasting color, inside left chest 2-tier 4-division pencil pocket, lower right inside patch pocket, with Mic Tab on front left chest, with Road and Bridge imprinted on back, Size: 4XL	100		\$ -
Safetey vests, ML Kishigo Ultra-Cool mesh, contrasting #1056 (or equal), ANSI/ISEA 107 2010 Class 2 compliant, zipper front closure, 2" wide reflective material with 4.5" contrasting color, inside left chest 2-tier 4-division pencil pocket, lower right inside patch pocket, with Mic Tab on front left chest, with Road and Bridge imprinted on back, Size: 5XL	100		\$ -
Total Section 10:			\$ -

Vendor Name: Core Products, LLC

Section 11: Stop/Slow Paddles	Estimated Annual Quantity	Bid Price per Each	Extended Cost
Stop/slow paddles, 24" aluminum, Diamond Grade reflective with 12" handle	10		\$ -
Extension handles, telescopic with 2 height settings for 6' and 7' height	10		\$ -
Total Section 11:			\$ -

Section 12: Miscellaneous	Estimated Annual Quantity	Bid Price per Each	Extended Cost
Yellow water base traffic paint for stripping roads in	1100		\$ -
White water base traffic paint for stripping roads in	1100		\$ -
Blue water base traffic paint for stripping roads in gallons	1100		\$ -
Red water base traffic paint for stripping roads in gallons	1100		\$ -
Black water base traffic paint for stripping roads in gallons	1100		\$ -
Glass beads, in pounds, 50 pounds per bag	1000		\$ -
Bitumem adhesive for raised pavement markings in	5000		\$ -
Total Section 12:			\$ -



It Straps On, Inc.

74525 Oil Row • Covington, LA 70435
Office: (985) 875-0080 Fax: (985) 875-0088
www.itstrapson.com

Specification Sheet for BA206

We test all our Type 201 stainless steel band to ensure that it meets the ASTM-A666 standards, including but not limited to those on chemical composition requirements of carbon, manganese, phosphorus, sulfur, silicon, chromium, nickel, tensile and break strength. Our BA206 is fully annealed.

Our Type 201 stainless steel band is produced and manufactured in the **U.S.A.**

✿ ✿ TYPE 201 MADE IN THE USA ## 6521 ## ✿ ✿

Unique quality control: Referencing the test results, a 4-digit code is printed every 12 inches on the band. This code proves the steel's authenticity and compliance with ASTM standards while serving as a handy measuring point. This process is unique to ISO.

BA206 can be further described as:

Edging: Skived

Finish: Stainless matte

Thickness: .030"

Width: 3/4"

Length: 100'

Break Strength: 2,200 Lbs. Minimum

Tensile Strength: 95,000 PSI Minimum

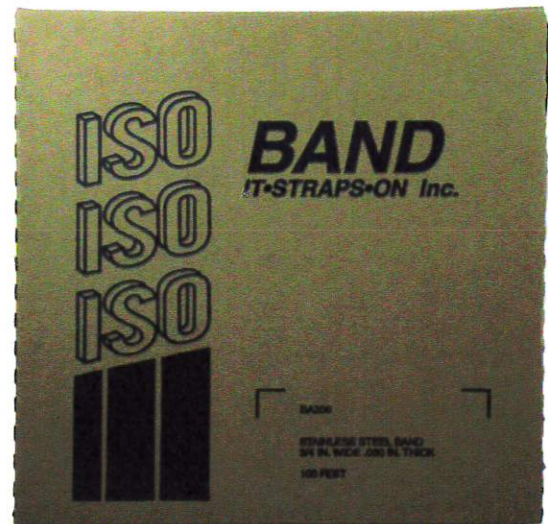



It Straps On® Inc.

74525 Oil Row

Covington, LA 70435

Office: (985) 875-0080 Fax: (985) 875-0088

www.itstrapson.com

Specification Sheet for SB021

We test all our Bull's Eye® stainless steel flared leg sign bracket material to warrant that it meets ASTM-A240 standards, including, but not limited to those on chemical composition requirements of carbon, manganese, phosphorus, sulfur, silicon, chromium, nickel and tensile strength.

Our Bull's Eye® stainless steel flared leg sign brackets are produced and manufactured in the ***U.S.A.***

Our SB021 Bull's Eye® stainless steel flared leg sign brackets are fully annealed and come with a stainless steel bolt (5/16", 18 thread, hex head) and washer.

SB021 can be further described as:

Finish: Stainless bright or matte
Thickness: .070"
Pieces per box: 50
Tensile Strength: 55,000 PSI Minimum

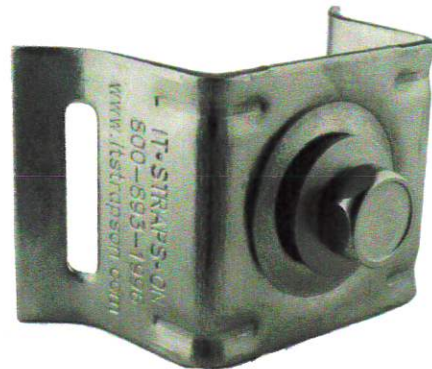



It Straps On, Inc.

74525 Oil Row

Covington, LA 70435

Office: (985) 875-0080 Fax: (985) 875-0088

www.itstrapson.com

Specification Sheet for WS156

We test all our Type 201 stainless steel wing seal material to ensure that it meets ASTM-A666 standards, including, but not limited to those on chemical composition requirements of carbon, manganese, phosphorus, sulfur, silicon, chromium, nickel and tensile strength.

Our stainless steel wing seals are produced and manufactured in the ***U.S.A.***

Our Type 201 WS156 stainless steel wing seals are fully annealed.

WS156 can be further described as:

Finish: Stainless bright or matte

Thickness: .044"

Pieces per box: 100

Width: 3/4"

Tensile Strength: 95,000 PSI Minimum

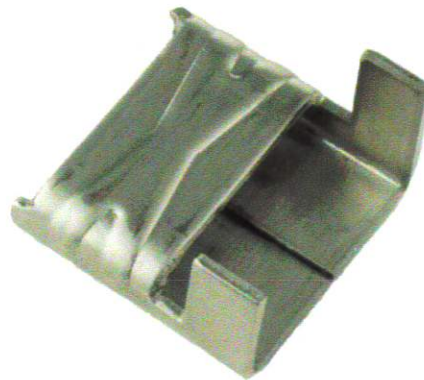



COUNTY PURCHASING AGENT
Fort Bend County, Texas

Vendor Information

Jaime Kovar
County Purchasing Agent

Office (281) 341-8640

Legal Company Name (top line of W9)	Dobie Supply, LLC.		
Business Name (if different from legal name)			
Federal ID # or S.S. #	45-5485450	DUNS #	015845455
Type of Business	<input checked="" type="checkbox"/> Corporation/LLC <input type="checkbox"/> Sole Proprietor/Individual	<input type="checkbox"/> Partnership <input type="checkbox"/> Tax Exempt Organization	Age in Business? 9 years
Publicly Traded Business	<input checked="" type="checkbox"/> No <input type="checkbox"/> Yes Ticker Symbol _____		
Remittance Address	3809 S. 2nd St. #D200		
City/State/Zip	Austin, TX. 78704		
Physical Address	601 Commercial Dr.		
City/State/Zip	Buda, TX. 78610		
Phone/Fax Number	Phone: 512-437-6499 Fax: 512-444-0796		
Contact Person	Valera Byrd		
E-mail	Val@dobieSupply.com		
Check all that apply to the company listed above and provide certification number.	DBE-Disadvantaged Business Enterprise _____	Certification # _____	
	SBE-Small Business Enterprise _____	Certification # _____	
	HUB -Texas Historically Underutilized Business _____	Certification # _____	
	WBE-Women's Business Enterprise _____	Certification # _____	
Company's gross annual receipts	<\$500,000 _____	\$500,000-\$4,999,999 _____	
	\$5,000,000-\$16,999,999 <input checked="" type="checkbox"/>	\$17,000,000-\$22,399,999 _____	
	>\$22,400,000 _____		
NAICs codes (Please enter all that apply)			
Signature of Authorized Representative			
Printed Name	Valera Byrd		
Title	Director of Sales		
Date	1-14-21		

THIS FORM MUST BE SUBMITTED WITH THE SOLICITATION RESPONSE

*Fort Bend County, Texas
Invitation for Bid*

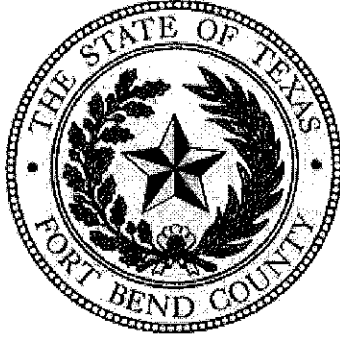

*Term Contract for the Purchase of Traffic Signs, Posts and Supplies
BID 21-048*

SUBMIT BIDS TO:

Fort Bend County
Purchasing Department
Travis Annex
301 Jackson, Suite 201
Richmond, TX 77469

Note: All correspondence must include the term
"Purchasing Department" in address to assist in
proper delivery.

SUBMIT NO LATER THAN:

Tuesday, January 19, 2021
2:00 PM (Central)

LABEL ENVELOPE:

BID 21-048
TRAFFIC SIGNS, POSTS, SUPPLIES

*ALL BIDS MUST BE RECEIVED IN AND TIME/DATE STAMPED BY THE PURCHASING OFFICE
OF FORT BEND COUNTY BEFORE THE SPECIFIED TIME/DATE STATED ABOVE.*

BIDS RECEIVED AS REQUIRED WILL THEN BE OPENED AND PUBLICLY READ.

BIDS RECEIVED AFTER THE SPECIFIED TIME, WILL BE RETURNED UNOPENED.

Results will not be given by phone.
Results will be provided to bidder in writing
after the Commissioners Court awards.

Requests for information must be in
writing and directed to:
Cheryl Krejci, CPPB
Senior Buyer
cheryl.krejci@fortbendcountytexas.gov

Vendor Responsibilities:

- Download and complete any addendums. (Addendums will be posted on the Fort Bend County website no
Later than 48 hours prior to bid opening)
- Submit response in accordance with requirements stated on the cover of this document.
- DO NOT submit responses via email or fax.

1.0 GENERAL REQUIREMENTS:

- 1.1 Read this entire document carefully. Follow all instructions. You are responsible for fulfilling all requirements and specifications. Be sure you understand them.
- 1.2 General Requirements apply to all advertised bids, however, these may be superseded, whole or in part, by the scope, special requirements, specifications, special specifications or other data contained herein.
- 1.3 Governing Law: Bidder is advised that these requirements shall be fully governed by the laws of the State of Texas and that Fort Bend County may request and rely on advice, decisions and opinions of the Attorney General of Texas and the County Attorney concerning any portion of these requirements.
- 1.4 Bid Document Completion: Fill out, initial each page, sign, and return ONE (1) complete bid document to the Fort Bend County Purchasing Department. An authorized representative of the bidder must sign the Contract Sheet. Do not complete the date at the top of the contract sheet. The bid document must be in a sealed envelope marked with the appropriate bid number and title. The contract will be binding only when signed by the County Judge, Fort Bend County and a purchase order authorizing the item(s) desired has been issued. The use of correction fluid is not acceptable and may result in the disqualification of bid. If an error is made, the bidder must draw a line through error and initial each change. All response, typed or written, information must be clear and legible.

If a pricing form in Excel is included and posted on the County's website amongst this bid document, the Vendor must download, complete and save the Excel (not a PDF of the Excel file) file of the pricing form on a CD or flash drive. The Excel file on the CD or flash drive must be downloadable by the Purchasing Department in order to copy and paste the vendor's pricing to the County's tabulation. The CD or flash drive must be labeled and included in the same sealed envelope with the respondent's completed bid document along with a printed copy of the pricing form completed by the vendor.

- 1.5 Bid Returns: Bidders must return completed bid document to the Fort Bend County Purchasing Department at 301 Jackson, Suite 201, Richmond, Texas no later than 2:00 P.M. on the date specified. Late bids will not be accepted. Bids must be submitted in a sealed envelope, addressed as follows: Fort Bend County Purchasing Agent, Travis Annex, 301 Jackson, Suite 201, Richmond, Texas 77469.
- 1.6 Governing Document: In the event of any conflict between the terms and provisions of these requirements and the specifications, the specifications shall govern. In the event of any conflict of interpretation of any part of this overall document, Fort Bend County's interpretation shall govern.

Initials of Bidder: VB

- 1.7 Addenda: No interpretation of the meaning of the drawings, specifications or other bid documents will be made to any bidder orally. All requests for such interpretations must be made in writing addressed to Ms. Cheryl Krejci, Senior Buyer, 301 Jackson, Suite 201, Richmond, Texas 77469, e-mail: cheryl.krejci@fortbendcountytexas.gov. Any and all interpretations and any supplemental instructions will be in the form of written addenda to the contract documents which will be posted on Fort Bend County's website. Addenda will **ONLY** be issued by the Fort Bend County Purchasing Agent. It is the sole responsibility of each bidder to insure receipt of any and all addenda. All addenda issued will become part of the contract documents. Bidders must sign and include addendum in the returned bid package. Deadline for submission of questions and/or clarification is **Tuesday, January 12, 2021 at 9:00 a.m. (CST)**. Requests received after the deadline will not be responded to due to the time constraints of this bid process.
- 1.8 Hold Harmless Agreement: Contractor shall indemnify and hold Fort Bend County harmless from all claims for personal injury, death and/or property damage arising from any cause whatsoever, resulting directly or indirectly from contractor's performance. Contractor shall procure and maintain, with respect to the subject matter of this bid, appropriate insurance coverage including, as a minimum, public liability and property damage with adequate limits to cover contractor's liability as may arise directly or indirectly from work performed under terms of this bid. Certification of such coverage must be provided to the County upon request.
- 1.9 Waiver of Subrogation: Bidder and bidder's insurance carrier waive any and all rights whatsoever with regard to subrogation against Fort Bend County as an indirect party to any suit arising out of personal or property damages resulting from bidder's performance under this agreement.
- 1.10 Severability: If any section, subsection, paragraph, sentence, clause, phrase or word of these requirements or the specifications shall be held invalid, such holding shall not affect the remaining portions of these requirements and the specifications and it is hereby declared that such remaining portions would have been included in these requirements and the specifications as though the invalid portion had been omitted.
- 1.11 Bonds: If this bid requires submission of bid guarantee and performance bond, there will be a separate page explaining those requirements. Bids submitted without the required bid bond or cashier's checks are not acceptable. Bond/s or cashier's check must be complete with all required signatures.
- 1.12 Taxes: Fort Bend County is exempt from all federal excise, state and local taxes unless otherwise stated in this document. Fort Bend County claims exemption from all sales and/or use taxes under Chapter 20, Title 122a, Vernon's Texas Civil Statutes, as amended. Texas Limited Sales Tax Exemption Certificates will be furnished upon written request to the Fort Bend County Purchasing Department.

Initials of Bidder: MB

- 1.13 Fiscal Funding: A multi-year lease or lease/purchase arrangement (if requested by the specifications), or any contract continuing as a result of an extension option, must include fiscal funding out. If, for any reason, funds are not appropriated to continue the lease or contract, said lease or contract shall become null and void. After expiration of the lease, leased equipment shall be removed by the bidder from the using department without penalty of any kind or form to Fort Bend County. All charges and physical activity related to delivery, installation, removal and redelivery shall be the responsibility of the bidder.
- 1.14 Pricing: Prices for all goods and/or services shall be firm for the duration of this contract and shall be stated in the bid spreadsheet. Prices shall be all inclusive. No price changes, additions, or subsequent qualifications will be honored during the course of the contract. All prices must be written in ink or typewritten. Pricing on all transportation, freight, and other charges are to be prepaid by the contractor and included in the bid prices. If there are any additional charges of any kind, other than those mentioned above, specified or unspecified, bidder MUST indicate the items required and attendant costs or forfeit the right to payment for such items.
- 1.15 Silence of Specifications: The apparent silence of specifications as to any detail, or the apparent omission from it of a detailed description concerning any point, shall be regarded as meaning that only the best commercial practice is to prevail and that only material and workmanship of the finest quality are to be used. All interpretations of specifications shall be made on the basis of this statement. The items furnished under this contract shall be new, unused of the latest product in production to commercial trade and shall be of the highest quality as to materials used and workmanship. Manufacturer furnishing these items shall be experienced in design and construction of such items and shall be an established supplier of the item bid.
- 1.16 Supplemental Materials: Bidders are responsible for including all pertinent product data in the returned bid package. Literature, brochures, data sheets, specification information, completed forms requested as part of the bid package and any other facts which may affect the evaluation and subsequent contract award should be included. Materials such as legal documents and contractual agreements, which the bidder wishes to include as a condition of the bid, must also be in the returned bid package. Failure to include all necessary and proper supplemental materials may be cause to reject the entire bid.
- 1.17 Material Safety Data Sheets: Under the "Hazardous Communication Act", commonly known as the "Texas Right To Know Act", a bidder must provide to County and using departments, with each delivery, material safety data sheets, which are, applicable to hazardous substances defined in the Act. Bidders are obligated to maintain a current, updated file in the Fort Bend County Purchasing Department. Failure of the bidder to maintain such a file will be cause to reject any bid applying thereto.

Initials of Bidder: WB

- 1.18 Name Brands: Specifications may reference name brands and model numbers. It is not the intent of Fort Bend County to restrict these bids in such cases, but to establish a desired quality level of merchandise or to meet a pre-established standard due to like existing items. Bidders may offer items of equal stature and the burden of proof of such stature rests with them. Fort Bend County shall act as sole judge in determining equality and acceptability of products offered.
- 1.19 Color Selection: Determination of colors of materials is a right reserved by the using department unless otherwise specified in the bid. Unspecified colors shall be quoted as standard colors, not colors, which require up charges or special handling. Unspecified fabrics or vinyl should be construed as medium grade. If bidder fails to get color/material approvals prior to delivery of merchandise, the using department may refuse to accept the items and demand correct shipment without penalty, subject to other legal remedies.
- 1.20 Evaluation: Evaluation shall be used as a determinant as to which bid items or services are the most efficient and/or most economical for the County. It shall be based on all factors, which have a bearing on price and performance of the items in the user environment. All bids are subject to tabulation by the Fort Bend County Purchasing Department and recommendation to Fort Bend County Commissioners Court. Compliance with all bid requirements, delivery and needs of the using department are considerations in evaluating bids. Pricing is NOT the only criteria for making a recommendation. The Fort Bend County Purchasing Department reserves the right to contact any bidder, at any time, to clarify, verify or request information with regard to any bid.
- 1.21 Inspections: Fort Bend County reserves the right to inspect any item(s) or service location for compliance with specifications and requirements and needs of the using department. If a bidder cannot furnish a sample of a bid item, where applicable, for review, or fails to satisfactorily show an ability to perform, the County can reject the bid as inadequate.
- 1.22 Testing: Fort Bend County reserves the right to test equipment, supplies, material and goods bid for quality, compliance with specifications and ability to meet the needs of the user. Demonstration units must be available for review. Should the goods or services fail to meet requirements and/or be unavailable for evaluation, the bid is subject to rejection.
- 1.23 Disqualification of Bidder: Upon signing this bid document, a bidder offering to sell supplies, materials, services, or equipment to Fort Bend County certifies that the bidder has not violated the antitrust laws of this state codified in section 15.01, et seq., Business & Commerce Code, or the federal antitrust laws, and has not communicated directly or indirectly the bid made to any competitor or any other person engaged in such line of business. Any or all bids may be rejected if the County believes that collusion exists among the bidders. Bids in which the prices are

Initials of Bidder: WS

obviously unbalanced may be rejected. If multiple bids are submitted by a bidder and after the bids are opened, one of the bids is withdrawn, the result will be that all of the bids submitted by that bidder will be withdrawn; however, nothing herein prohibits a vendor from submitting multiple bids for different products or services.

- 1.24 Awards: Fort Bend County reserves the right to award this contract on the basis of lowest and best bid in accordance with the laws of the State of Texas, to waive any formality or irregularity, to make awards to more than one bidder, to reject any or all bids. In the event the lowest dollar bidder meeting specifications is not awarded a contract, the bidder may appear before the Commissioners Court and present evidence concerning his responsibility. An award is final only upon formal execution by the Fort Bend County Commissioners Court or the Fort Bend County Purchasing Agent. Fort Bend County reserves the right to withdraw any award until execution by the proper authority.
- 1.25 Assignment: The successful vendor may not assign, sell or otherwise transfer this contract without written permission of Fort Bend County Commissioners Court.
- 1.26 Term Contracts: If the contract is intended to cover a specific time period, said time will be given in the specifications under scope.
- 1.27 Maintenance: Maintenance required for equipment bid should be available in Fort Bend County by a manufacturer authorized maintenance facility. Costs for this service shall be shown on the bid sheet as requested or on a separate sheet, as required. If Fort Bend County opts to include maintenance, it shall be so stated in the purchase order and said cost will be included. Service will commence only upon expiration of applicable warranties and should be priced accordingly.
- 1.28 Contract Obligation: Fort Bend County Commissioners Court must award the contract and the County Judge or other person authorized by the Fort Bend County Commissioners Court must sign the contract before it becomes binding on Fort Bend County or the bidders. Department heads are not authorized to sign agreements for Fort Bend County. Binding agreements shall remain in effect until all products and/or services covered by this purchase have been satisfactorily delivered and accepted.
- 1.29 Title Transfer: Title and Risk of Loss of goods shall not pass to Fort Bend County until Fort Bend County actually receives and takes possession of the goods at the point or points of delivery. Receiving times may vary with the using department. Generally, deliveries may be made between 8:30 a.m. and 4:00 p.m., Monday through Friday. Bidders are advised to consult the using department for instructions. The place of delivery shall be shown under the "Special Requirement" section of this bid document and/or on the Purchase Order as a "Ship To:" address.
- 1.30 Purchase Order and Delivery: The successful bidder shall not deliver products or

Initials of Bidder: WB

provide services without a Fort Bend County Purchase Order, signed by an authorized agent of the Fort Bend County Purchasing Department. The fastest, most reasonable delivery time shall be indicated by the bidder in the proper place on the bid sheet. Any special information concerning delivery should also be included, on a separate sheet, if necessary. All items shall be shipped F.O.B. inside delivery unless otherwise stated in the specifications. This shall be understood to include bringing merchandise to the appropriate room or place designated by the using department. Every tender or delivery of goods must fully comply with all provisions of these requirements and the specifications including time, delivery and quality. Nonconformance shall constitute a breach, which must be rectified prior to expiration of the time for performance. Failure to rectify within the performance period will be considered cause to reject future deliveries and cancellation of the contract by Fort Bend County without prejudice to other remedies provided by law. Where delivery times are critical, Fort Bend County reserves the right to award accordingly.

- 1.31 Contract Extension: Extensions may be made only by written agreement between Fort Bend County and the bidder. Any price escalations are limited to those stated by the bidder in the original bid.
- 1.32 Termination: Fort Bend County reserves the right to terminate the contract for default if Seller breaches any of the terms therein, including warranties of bidder or if the bidder becomes insolvent or commits acts of bankruptcy. Such right of termination is in addition to and not in lieu of any other remedies, which Fort Bend County may have in law or equity. Default may be construed as, but not limited to, failure to deliver the proper goods and/or services within the proper amount of time, and/or to properly perform any and all services required to Fort Bend County's satisfaction and/or to meet all other obligations and requirements. Contracts may be terminated without cause upon thirty (30) days written notice to either party unless otherwise specified.
- 1.33 Recycled Materials: Fort Bend County encourages the use of products made of recycled materials and shall give preference in purchasing to products made of recycled materials if the products meet applicable specifications as to quantity and quality. Fort Bend County will be the sole judge in determining product preference application.
- 1.34 Interlocal Participation: Additional governmental entities may purchase from this bid. Vendor agrees to accept purchase orders from those participating entities and to invoice each entity separately.
- 1.35 Escalation Clause: Successful bidder may apply for a price increase to the Fort Bend County Purchasing Agent. The County Purchasing Agent will review, and, if increase is deemed warranted, place the request on Fort Bend County's Commissioners Court agenda for their action of approval or disapproval. Approval by the County's Commissioner's Court is required. Any proposed price increase will

Initials of Bidder: MB

only be the amount increased to the vendor from his/her supplier. The price increase request must be stated on the vendor's letterhead with the bid number and name in the subject including, in columns, for each item: item description, original bid price, percent of increase, and the total cost of the original bid price including the increased dollar amount. Written documentation from the vendor's supplier of the increase notice must be provided to the Purchasing Agent at time of increase request. No application for a price increase may be submitted within the first six (6) months of this contract. Increase requests of more than 25% of the original bid price will not be considered.

- 1.36 Modifications: This instrument contains the entire Contract between the parties relating to the rights herein granted and obligations herein assumed. Any oral or written representations or modifications concerning this instrument shall be of no force and effect excepting a subsequent written modification signed by both parties hereto.

2.0 TERMS & CONDITIONS:

- 2.1 Seller to Package Goods: Seller will package goods in accordance with good commercial practice. Each delivery container shall be clearly and permanently marked as follows (a) Seller's name and address; (b) Consignee's name, address and purchase order number and the bid number if applicable; (c) Container number and total number of containers (e.g. box 1 of 4 boxes); and (d) the number of the container bearing the packing slip. Seller shall bear cost of packaging unless otherwise provided. Goods shall be suitably packed to secure lowest transportation costs and to conform to requirements of common carriers and any applicable specifications. Fort Bend County's count or weight shall be final and conclusive on shipments not accompanied by packing list.
- 2.2 Shipment Under Reservation Prohibited: Seller is not authorized to ship goods under reservation and no tender of a bill of lading will operate as a tender of goods.
- 2.3 Title and Risk of Loss: The title and risk of loss of the goods shall not pass to the County until a County employee actually receives and takes possession of the goods at the point or points of delivery.
- 2.4 Delivery Terms: F.O.B. Destination Freight Prepaid, Inside Delivery, unless delivery terms are specified otherwise on Purchase Order.
- 2.5 No Replacement of Defective Tender: Every tender or delivery of goods must fully comply with all provisions of the Purchase Order as to time of delivery, quality and the like. If a tender is made which does not fully conform, this shall constitute a breach and Seller shall not have the right to substitute a conforming tender.
- 2.6 Place of Delivery: The place of delivery shall be that set forth in the block of the

Initials of Bidder: VB

purchase order entitled "Ship To". Any change thereto shall be effective by modification as provided for in Clause number 2.20 "Modifications", hereof. The terms of this agreement are "no arrival, no sale", at the discretion of Fort Bend County.

2.7 Invoices and Payments:

2.7.1 Seller shall submit separate invoices, in duplicate. Invoices shall indicate the purchase order number and the bid number if applicable. Invoices shall be itemized and transportation charges, if any, shall be listed separately. A copy of the bill of lading, and the freight waybill when applicable should be attached to the invoice.

2.7.2 Fort Bend County's obligation is payable only and solely from funds available for the purpose of this purchase. Lack of funds shall render the order null and void to the extent funds are not available and any delivered but unpaid goods will be returned to Seller by the county.

2.7.3 Do not include Federal Excise, State, or City Sales Tax. Fort Bend County is a tax-exempt governmental entity.

2.8 Gratuities: Fort Bend County may, by written notice to the Seller, cancel any order without liability, if it is determined by the County that gratuities, in the form of entertainment, gifts, or otherwise were offered or given by the Seller, or any agent or representative of the Seller to any officer or employee of Fort Bend County with a view toward securing an order. In the event an order is canceled by the County pursuant to this provision, the County shall be entitled, in addition to any other rights and remedies, to recover or withhold the amount of the cost incurred by Seller in providing such gratuities.

2.9 Special Tools and Test Equipment: If the price stated on the face of an order includes the cost of any special tooling or special test equipment fabricated or required by Seller for the purpose of filing this order, such special tooling equipment and any process sheets related thereto shall become the property of the County and to the extent feasible shall be identified by the Seller as such.

2.10 Warranty/Price:

2.10.1 The price to be paid by the County shall be that contained in Seller's bid which Seller warrants to be no higher than Seller's current prices on orders by others for products of the kind and specification covered by an order for similar quantities under similar or like conditions and methods of purchase. In the event Seller breaches this warranty the prices of the items shall be reduced to the Seller's current prices on orders by others. Fort Bend County may cancel this contract without liability.

Initials of Bidder: Mo

- 2.10.2 The Seller warrants that no person or selling agency has been employed or retained to solicit or secure any County order based upon any agreement or understanding for commission, percentage, brokerage, or contingent fee excepting bona fide employees of bona fide established commercial or selling agencies maintained by the Seller for the purpose of securing business. A breach or violation of this warranty gives the County the right, in addition to any other right or rights, to cancel this contract without liability.
- 2.11 Warranty Product: Seller shall not limit or exclude any implied warranties and any attempt to do so shall render an order voidable at the option of the County. Seller warrants that the goods furnished will conform to the specifications, drawings, and description listed in the bid invitation and purchase order as applicable, and to the sample(s) furnished by Seller if any. In the event of a conflict between the specifications, drawings, and descriptions, the specifications shall govern.
- 2.12 Safety Warranty: Seller warrants that the product sold to Fort Bend County shall conform to the standards promulgated by the U.S. Department of Labor under the Occupational Safety and Health Act of 1970. In the event the product does not conform to OSHA standards, the County may return the product for correction or replacement at the Seller's expense. In the event Seller fails to make the appropriate correction within 10 days, correction made by the County will be at Seller's expense.
- 2.13 No Warranty by Fort Bend County Against Infringements: As part of a contract for sale Seller agrees to ascertain whether goods manufactured in accordance with the specifications will give rise to the rightful claim of any third person by way of infringement. Fort Bend County makes no warranty that the production of goods according to the specification will not give rise to such a claim and in no event shall Fort Bend County be liable to Seller for indemnification in the event the Seller is sued on the grounds of infringement or the like. If Seller is of the opinion that an infringement will result, he will notify Fort Bend County to this effect in writing within two days after the receiving Purchase Order. If the County does not receive notice and is subsequently held liable for the infringement, Seller will defend and save the County harmless. If Seller in good faith ascertains that production of the goods in accordance with the specifications will result in infringement, this contract shall be null and void except that the County will pay Seller the reasonable cost of his search as to infringements.
- 2.14 Right of Inspection: The County shall have the right to inspect the goods at delivery before accepting them.
- 2.15 Cancellation: Fort Bend County shall have the right to cancel for default all or any part of the undelivered portion of an order if Seller breaches any of the terms hereof including warranties of Seller, or if the Seller becomes insolvent or files for protection under the bankruptcy laws. Such rights of cancellation are in addition to and not in lieu of any other remedies, which Fort Bend County may have in law or

Initials of Bidder: AKS

equity.

- 2.16 Termination: The performance of work under a Purchase Order may be terminated in whole or in part by the County in accordance with this provision. Termination of work there under shall be effected by the delivery to the Seller of a "Notice of Termination" specifying the extent to which performance of work under the order is terminated and the date upon which such termination becomes effective. Such right of termination is in addition to and not in lieu of rights of Fort Bend County set forth in Clause 15 herein.
- 2.17 Force Majeure: Force Majeure means a delay encountered by a party in the performance of its obligations under this Agreement, which is caused by an event beyond the reasonable control of that party. Without limiting the generality of the foregoing, "Force Majeure" shall include but not be restricted to the following types of events: acts of God or public enemy; acts of governmental or regulatory authorities; fires, floods, epidemics or serious accidents; unusually severe weather conditions; strikes, lockouts, or other labor disputes; and defaults by subcontractors.
- In the event of a Force Majeure, the affected party shall not be deemed to have violated its obligations under this Agreement, and the time for performance of any obligations of that party shall be extended by a period of time necessary to overcome the effects of the Force Majeure, provided that the foregoing shall not prevent this Agreement from terminating in accordance with the termination provisions. If any event constituting a Force Majeure occurs, the affected party shall notify the other parties in writing, within twenty-four (24) hours, and disclose the estimated length of delay, and cause of the delay.
- 2.18 Assignment-Delegation: No right or interest in an order shall be assigned or delegation of any obligation made by Seller without the written permission of Fort Bend County. Any attempted assignment or delegation by Seller shall be wholly void and totally ineffective for all purposes unless made in conformity with this paragraph.
- 2.19 Waiver: No claim or right arising out of a breach of any contract can be discharged in whole or in part by a waiver or renunciation of the claim or right unless the waived or renunciation is supported by consideration and is in writing signed by the aggrieved party.
- 2.20 Modification: A Purchase Order can be modified or rescinded only by a writing signed by both of the parties or their duly authorized agents.
- 2.21 Parol Evidence: This writing is intended by the parties as a final expression of their agreement and is intended also as a complete and exclusive statement of the terms of this agreement. No course of prior dealings between the parties and no usage of the trade shall be relevant to supplement or explain any terms rendered under this agreement and shall not be relevant to determine the meaning of this agreement even

Initials of Bidder: VB

though the accepting or acquiescing party has knowledge of the performance and opportunity for objection. Whenever a term defined by the Uniform Commercial Code is used in this agreement, the definition contained in the Code is to control.

- 2.22 **Applicable Law:** This agreement shall be governed by the Uniform Commercial Code. Whenever the term "Uniform Commercial Code" is used it shall be construed as meaning the Uniform Commercial Code as adopted in the State of Texas and in effective on the date of the purchase order.
- 2.23 **Advertising:** Seller shall not advertise or publish, without the County's prior consent the fact that Fort Bend County has entered into any contract, except to the extent necessary to comply with proper requests for information from an authorized representative of the federal, state, or local government.
- 2.24 **Right to Assurance:** Whenever the County in good faith has reason to question the other party's intent to perform. The County may demand that the other party give written assurance of his intent to perform. In the event that a demand is made and no assurance is given within five (5) days, the County may treat this failure as an anticipatory repudiation of the contract.
- 2.25 **Venue:** Both parties agree that venue for any litigation arising from this contract shall lie in Richmond, Fort Bend County, Texas.
- 2.26 **Prohibition Against Personal Interest in Contracts:** No officer or employee of the County shall have a financial interest, direct or indirect, in any contract with the County, or shall be financially interested, directly or indirectly, in the sale to the County of any land, materials, supplies, or service, except on behalf of the County as an officer or employee. Any willful violation of this section shall constitute malfeasance in office, and any officer or employee guilty thereof shall be subject to disciplinary action under applicable laws, statutes and codes of the State of Texas. Any violation of this section, with the knowledge, expressed or implied of the person or corporation contracting with the County shall render the contract involved voidable by the County Commissioners Court.

3.0 SCOPE:

It is the intent of Fort Bend County to contract with one (1) or more vendors to provide traffic signs, posts and supplies for Fort Bend County as specified herein.

4.0 TERM OF CONTRACT:

The term of this contract is **April 1, 2021 through March 31, 2022**, renewable annually for four (4) years (through 31 March 2026) under the same terms and conditions if mutually agreeable by both parties. Either party for any reason may terminate this contract by giving thirty (30) days written notice of the intent to terminate.

Initials of Bidder: VB

5.0 TEXAS ETHICS COMMISSION FORM 1295:

- 5.1 Effective January 1, 2016 all contracts executed by Commissioners Court, regardless of the dollar amount, will require completion of Form 1295 "Certificate of Interested Parties", per the new Government Code Statute §2252.908. All vendors submitting a response to a formal Bid, RFP, SOQ or any contracts, contract amendments, renewals or change orders are required to complete the Form 1295 online through the State of Texas Ethics Commission website. Please visit: https://www.ethics.state.tx.us/whatsnew/elf_info_form1295.htm.
- 5.2 On-line instructions:
 - 5.2.1 Name of governmental entity is to read: Fort Bend County.
 - 5.2.2 Identification number used by the governmental entity is: B21-048.
 - 5.2.3 Description is the title of the solicitation: Traffic Signs, Posts, Supplies.
- 5.3 Apparent low bidder(s) will be required to provide the Form 1295 within three (3) calendar days from notification; however, if your company is publicly traded you are not required to complete this form.

6.0 STATE LAW REQUIREMENTS FOR CONTRACTS:

The contents of this section are required by Texas Law and are included by County regardless of content.

- 6.1 Agreement to Not Boycott Israel Chapter 2270 Texas Government Code: By signature on vendor form, Contractor verifies Contractor does not boycott Israel and will not boycott Israel during the term of this Contract.
- 6.2 Texas Government Code Section 2251.152 Acknowledgment: By signature on vendor form, Contractor represents pursuant to Section 2252.152 of the Texas Government Code, that Contractor is not listed on the website of the Comptroller of the State of Texas concerning the listing of companies that are identified under Section 806.051, Section 807.051 or Section 2253.153.

7.0 HUMAN TRAFFICKING:

By acceptance of this contract, Contractor acknowledges that Fort Bend County is opposed to human trafficking and that no County funds will be used in support of services or activities that violate human trafficking laws.

Initials of Bidder: MS

8.0 ASSIGNMENT:

Contractor shall not sell, assign, transfer or convey these services, in whole or in part, without the prior written consent of Fort Bend County and as a condition of such consent, contractor shall remain liable for completion of the services in the event of default by the successor contractor or assignee.

9.0 AWARD:

This contract will be awarded to the lowest and best bidder per section.

10.0 GENERAL:

- 10.1 Quantities listed are estimates only. Fort Bend County does not guarantee the quantities stated will be purchased.
- 10.2 No minimum orders, by quantity or dollar amount.
- 10.3 Bidders may be required to submit samples for inspection and evaluation after bid opening to determine acceptability.

11.0 DELIVERY:

- 11.1 Vendor must complete delivery within thirty (30) working days after receipt of purchase order.
- 11.2 The successful bidder shall not deliver products without a Purchase Order issued by the Fort Bend County Purchasing Agent.
- 11.3 The successful bidder shall not deliver products or services in excess of those authorized and under no circumstances will Fort Bend County be liable for payment of products or services, which exceed the amounts authorized by the purchase order.
- 11.4 All orders must be delivered between 8:00 AM and 3:00 PM, Monday through Friday to the address indicated on purchase order.

12.0 SPECIFICATIONS and BID PRICING:

Specifications are located in the Excel pricing form downloadable from Fort Bend County's website. Provide bid prices in the electronic Excel file and return as stated in Section 1.4 and 1.5.

13.0 QUALITY CONTROL:

Fort Bend County reserves the right to sample and test products at time of delivery for specification compliance in the presence of the driver or vendor's representative. Costs for tests shall be borne by the Contractor in the event product fails to meet specifications. Products not in their original

Initials of Bidder: VB

package will not be accepted.

14.0 REQUIRED FORMS:

All vendors submitting are required to complete and provide with submission:

- 14.1 Electronic Excel file of Pricing Form on CD or flash drive and printed hard copy
- 14.2 Vendor Form
- 14.3 W9 Form
- 14.4 Tax Form/Debt/Residence Certification

Initials of Bidder: VB

**Contract Sheet
Bid 21-048**

**THE STATE OF TEXAS
COUNTY OF FORT BEND**

This memorandum of agreement made and entered into on the 23rd day of March, 2021,
by and between Fort Bend County in the State of Texas (hereinafter designated County), acting herein by
County Judge KP George, by virtue of an order of Fort Bend County Commissioners Court, and
Dobie Supply (hereinafter designated Contractor).
(company name)

WITNESSETH:

The Contractor and the County agree that the bid and specifications for the **Purchase of Traffic Signs, Posts and Supplies** which are hereto attached and made a part hereof, together with this instrument and the bond (when required) shall constitute the full agreement and contract between parties and for furnishing the items set out and described; the County agrees to pay the prices stipulated in the accepted bid.

It is further agreed that this contract shall not become binding or effective until signed by the parties hereto and a purchase order authorizing the items desired has been issued.

Executed at Richmond, Texas this 23 day of March 2021.

KP George **Fort Bend County, Texas**
By: County Judge KP George
County Judge, KP George

[Signature]
By: Signature of Contractor
Signature of Contractor

By: Valera Byrd Sales Manager
Printed Name and Title

COUNTY PURCHASING AGENT

Fort Bend County, Texas

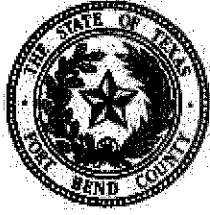

Jaime Kovar
County Purchasing Agent

(281) 341-8640
Fax (281) 341-8645

January 4, 2021

TO: All Prospective Bidders

RE: Addendum No. 1 – Fort Bend County Bid 21-048 – Traffic Signs, Posts & Supplies

Addendum 1:

Attached is addendum 1. Vendors are to use Addendum 1 document while preparing their solicitation response. Contract name updated on Contract Sheet, page 17.

Immediately upon your receipt of this addendum, please fill out the following information and email this page to Jessica Carabajal at jessica.carabajal@fortbendcountytexas.gov

Dobie Supply
Company Name

[Signature]
Signature of person receiving addendum

1-14-21
Date

If you have any questions, please contact this office.

Sincerely,

[Signature]

Cheryl Krejci
Senior Buyer

**Request for Taxpayer
 Identification Number and Certification**

**Give Form to the
 requester. Do not
 send to the IRS.**

1 Name (as shown on your income tax return). Name is required on this line; do not leave this line blank.
Dobie Supply LLC

2 Business name/disregarded entity name, if different from above

3 Check appropriate box for federal tax classification; check only one of the following seven boxes:
 Individual/sole proprietor or single-member LLC
 Limited liability company. Enter the tax classification (C=C corporation, S=S corporation, P=partnership) ▶ _____
 C Corporation
 S Corporation
 Partnership
 Trust/estate
 Other (see instructions) ▶ _____
Note. For a single-member LLC that is disregarded, do not check LLC; check the appropriate box in the line above for the tax classification of the single-member owner.

4 Exemptions (codes apply only to certain entities, not individuals; see instructions on page 3):
 Exempt payee code (if any) _____
 Exemption from FATCA reporting code (if any) _____
(Applies to accounts maintained outside the U.S.)

5 Address (number, street, and apt. or suite no.)
3809 S. 2nd St. #D200

6 City, state, and ZIP code
Austin, TX. 78704

7 List account number(s) here (optional)

Requester's name and address (optional)

Part I Taxpayer Identification Number (TIN)

Enter your TIN in the appropriate box. The TIN provided must match the name given on line 1 to avoid backup withholding. For individuals, this is generally your social security number (SSN). However, for a resident alien, sole proprietor, or disregarded entity, see the Part I instructions on page 3. For other entities, it is your employer identification number (EIN). If you do not have a number, see *How to get a TIN* on page 3.

Note. If the account is in more than one name, see the instructions for line 1 and the chart on page 4 for guidelines on whose number to enter.

Social security number	
or	
Employer identification number	
45	5485450

Part II Certification

Under penalties of perjury, I certify that:

- The number shown on this form is my correct taxpayer identification number (or I am waiting for a number to be issued to me); and
- I am not subject to backup withholding because: (a) I am exempt from backup withholding, or (b) I have not been notified by the Internal Revenue Service (IRS) that I am subject to backup withholding as a result of a failure to report all interest or dividends, or (c) the IRS has notified me that I am no longer subject to backup withholding; and
- I am a U.S. citizen or other U.S. person (defined below); and
- The FATCA code(s) entered on this form (if any) indicating that I am exempt from FATCA reporting is correct.

Certification instructions. You must cross out item 2 above if you have been notified by the IRS that you are currently subject to backup withholding because you have failed to report all interest and dividends on your tax return. For real estate transactions, item 2 does not apply. For mortgage interest paid, acquisition or abandonment of secured property, cancellation of debt, contributions to an individual retirement arrangement (IRA), and generally, payments other than interest and dividends, you are not required to sign the certification, but you must provide your correct TIN. See the instructions on page 3.

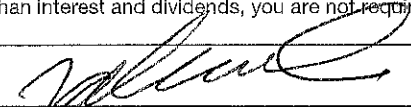
Sign Here Signature of U.S. person ▶  Date ▶ **1/17/21**

General Instructions

Section references are to the Internal Revenue Code unless otherwise noted.

Future developments. Information about developments affecting Form W-9 (such as legislation enacted after we release it) is at www.irs.gov/fw9.

Purpose of Form

An individual or entity (Form W-9 requester) who is required to file an information return with the IRS must obtain your correct taxpayer identification number (TIN) which may be your social security number (SSN), individual taxpayer identification number (ITIN), adoption taxpayer identification number (ATIN), or employer identification number (EIN), to report on an information return the amount paid to you, or other amount reportable on an information return. Examples of information returns include, but are not limited to, the following:

- Form 1099-INT (interest earned or paid)
- Form 1099-DIV (dividends, including those from stocks or mutual funds)
- Form 1099-MISC (various types of income, prizes, awards, or gross proceeds)
- Form 1099-B (stock or mutual fund sales and certain other transactions by brokers)
- Form 1099-S (proceeds from real estate transactions)
- Form 1099-K (merchant card and third party network transactions)

- Form 1098 (home mortgage interest), 1098-E (student loan interest), 1098-T (tuition)
 - Form 1099-C (canceled debt)
 - Form 1099-A (acquisition or abandonment of secured property)
- Use Form W-9 only if you are a U.S. person (including a resident alien), to provide your correct TIN.
- If you do not return Form W-9 to the requester with a TIN, you might be subject to backup withholding. See What is backup withholding? on page 2.*
- By signing the filled-out form, you:
- Certify that the TIN you are giving is correct (or you are waiting for a number to be issued),
 - Certify that you are not subject to backup withholding, or
 - Claim exemption from backup withholding if you are a U.S. exempt payee. If applicable, you are also certifying that as a U.S. person, your allocable share of any partnership income from a U.S. trade or business is not subject to the withholding tax on foreign partners' share of effectively connected income, and
 - Certify that FATCA code(s) entered on this form (if any) indicating that you are exempt from the FATCA reporting, is correct. See *What is FATCA reporting?* on page 2 for further information.

Note. If you are a U.S. person and a requester gives you a form other than Form W-9 to request your TIN, you must use the requester's form if it is substantially similar to this Form W-9.

Definition of a U.S. person. For federal tax purposes, you are considered a U.S. person if you are:

- An individual who is a U.S. citizen or U.S. resident alien;
- A partnership, corporation, company, or association created or organized in the United States or under the laws of the United States;
- An estate (other than a foreign estate); or
- A domestic trust (as defined in Regulations section 301.7701-7).

Special rules for partnerships. Partnerships that conduct a trade or business in the United States are generally required to pay a withholding tax under section 1446 on any foreign partners' share of effectively connected taxable income from such business. Further, in certain cases where a Form W-9 has not been received, the rules under section 1446 require a partnership to presume that a partner is a foreign person, and pay the section 1446 withholding tax. Therefore, if you are a U.S. person that is a partner in a partnership conducting a trade or business in the United States, provide Form W-9 to the partnership to establish your U.S. status and avoid section 1446 withholding on your share of partnership income.

In the cases below, the following person must give Form W-9 to the partnership for purposes of establishing its U.S. status and avoiding withholding on its allocable share of net income from the partnership conducting a trade or business in the United States:

- In the case of a disregarded entity with a U.S. owner, the U.S. owner of the disregarded entity and not the entity;
- In the case of a grantor trust with a U.S. grantor or other U.S. owner, generally, the U.S. grantor or other U.S. owner of the grantor trust and not the trust; and
- In the case of a U.S. trust (other than a grantor trust), the U.S. trust (other than a grantor trust) and not the beneficiaries of the trust.

Foreign person. If you are a foreign person or the U.S. branch of a foreign bank that has elected to be treated as a U.S. person, do not use Form W-9. Instead, use the appropriate Form W-8 or Form 8233 (see Publication 515, Withholding of Tax on Nonresident Aliens and Foreign Entities).

Nonresident alien who becomes a resident alien. Generally, only a nonresident alien individual may use the terms of a tax treaty to reduce or eliminate U.S. tax on certain types of income. However, most tax treaties contain a provision known as a "saving clause." Exceptions specified in the saving clause may permit an exemption from tax to continue for certain types of income even after the payee has otherwise become a U.S. resident alien for tax purposes.

If you are a U.S. resident alien who is relying on an exception contained in the saving clause of a tax treaty to claim an exemption from U.S. tax on certain types of income, you must attach a statement to Form W-9 that specifies the following five items:

1. The treaty country. Generally, this must be the same treaty under which you claimed exemption from tax as a nonresident alien.
2. The treaty article addressing the income.
3. The article number (or location) in the tax treaty that contains the saving clause and its exceptions.
4. The type and amount of income that qualifies for the exemption from tax.
5. Sufficient facts to justify the exemption from tax under the terms of the treaty article.

Example. Article 20 of the U.S.-China income tax treaty allows an exemption from tax for scholarship income received by a Chinese student temporarily present in the United States. Under U.S. law, this student will become a resident alien for tax purposes if his or her stay in the United States exceeds 5 calendar years. However, paragraph 2 of the first Protocol to the U.S.-China treaty (dated April 30, 1984) allows the provisions of Article 20 to continue to apply even after the Chinese student becomes a resident alien of the United States. A Chinese student who qualifies for this exception (under paragraph 2 of the first protocol) and is relying on this exception to claim an exemption from tax on his or her scholarship or fellowship income would attach to Form W-9 a statement that includes the information described above to support that exemption.

If you are a nonresident alien or a foreign entity, give the requester the appropriate completed Form W-8 or Form 8233.

Backup Withholding

What is backup withholding? Persons making certain payments to you must under certain conditions withhold and pay to the IRS 28% of such payments. This is called "backup withholding." Payments that may be subject to backup withholding include interest, tax-exempt interest, dividends, broker and barter exchange transactions, rents, royalties, nonemployee pay, payments made in settlement of payment card and third party network transactions, and certain payments from fishing boat operators. Real estate transactions are not subject to backup withholding.

You will not be subject to backup withholding on payments you receive if you give the requester your correct TIN, make the proper certifications, and report all your taxable interest and dividends on your tax return.

Payments you receive will be subject to backup withholding if:

1. You do not furnish your TIN to the requester,
2. You do not certify your TIN when required (see the Part II instructions on page 3 for details),

3. The IRS tells the requester that you furnished an incorrect TIN,

4. The IRS tells you that you are subject to backup withholding because you did not report all your interest and dividends on your tax return (for reportable interest and dividends only), or

5. You do not certify to the requester that you are not subject to backup withholding under 4 above (for reportable interest and dividend accounts opened after 1983 only).

Certain payees and payments are exempt from backup withholding. See *Exempt payee code* on page 3 and the separate instructions for the Requester of Form W-9 for more information.

Also see *Special rules for partnerships* above.

What is FATCA reporting?

The Foreign Account Tax Compliance Act (FATCA) requires a participating foreign financial institution to report all United States account holders that are specified United States persons. Certain payees are exempt from FATCA reporting. See *Exemption from FATCA reporting code* on page 3 and the instructions for the Requester of Form W-9 for more information.

Updating Your Information

You must provide updated information to any person to whom you claimed to be an exempt payee if you are no longer an exempt payee and anticipate receiving reportable payments in the future from this person. For example, you may need to provide updated information if you are a C corporation that elects to be an S corporation, or if you no longer are tax exempt. In addition, you must furnish a new Form W-9 if the name or TIN changes for the account; for example, if the grantor of a grantor trust dies.

Penalties

Failure to furnish TIN. If you fail to furnish your correct TIN to a requester, you are subject to a penalty of \$50 for each such failure unless your failure is due to reasonable cause and not to willful neglect.

Civil penalty for false information with respect to withholding. If you make a false statement with no reasonable basis that results in no backup withholding, you are subject to a \$500 penalty.

Criminal penalty for falsifying information. Willfully falsifying certifications or affirmations may subject you to criminal penalties including fines and/or imprisonment.

Misuse of TINs. If the requester discloses or uses TINs in violation of federal law, the requester may be subject to civil and criminal penalties.

Specific Instructions

Line 1

You must enter one of the following on this line; do not leave this line blank. The name should match the name on your tax return.

If this Form W-9 is for a joint account, list first, and then circle, the name of the person or entity whose number you entered in Part I of Form W-9.

a. Individual. Generally, enter the name shown on your tax return. If you have changed your last name without informing the Social Security Administration (SSA) of the name change, enter your first name, the last name as shown on your social security card, and your new last name.

Note. ITIN applicant: Enter your individual name as it was entered on your Form W-7 application, line 1a. This should also be the same as the name you entered on the Form 1040/1040A/1040EZ you filed with your application.

b. Sole proprietor or single-member LLC. Enter your individual name as shown on your 1040/1040A/1040EZ on line 1. You may enter your business, trade, or "doing business as" (DBA) name on line 2.

c. Partnership, LLC that is not a single-member LLC, C Corporation, or S Corporation. Enter the entity's name as shown on the entity's tax return on line 1 and any business, trade, or DBA name on line 2.

d. Other entities. Enter your name as shown on required U.S. federal tax documents on line 1. This name should match the name shown on the charter or other legal document creating the entity. You may enter any business, trade, or DBA name on line 2.

e. Disregarded entity. For U.S. federal tax purposes, an entity that is disregarded as an entity separate from its owner is treated as a "disregarded entity." See Regulations section 301.7701-2(c)(2)(iii). Enter the owner's name on line 1. The name of the entity entered on line 1 should never be a disregarded entity. The name on line 1 should be the name shown on the income tax return on which the income should be reported. For example, if a foreign LLC that is treated as a disregarded entity for U.S. federal tax purposes has a single owner that is a U.S. person, the U.S. owner's name is required to be provided on line 1. If the direct owner of the entity is also a disregarded entity, enter the first owner that is not disregarded for federal tax purposes. Enter the disregarded entity's name on line 2, "Business name/disregarded entity name." If the owner of the disregarded entity is a foreign person, the owner must complete an appropriate Form W-8. Instead of a Form W-9. This is the case even if the foreign person has a U.S. TIN.

Line 2

If you have a business name, trade name, DBA name, or disregarded entity name, you may enter it on line 2.

Line 3

Check the appropriate box in line 3 for the U.S. federal tax classification of the person whose name is entered on line 1. Check only one box in line 3.

Limited Liability Company (LLC). If the name on line 1 is an LLC treated as a partnership for U.S. federal tax purposes, check the "Limited Liability Company" box and enter "P" in the space provided. If the LLC has filed Form 8832 or 2553 to be taxed as a corporation, check the "Limited Liability Company" box and in the space provided enter "C" for C corporation or "S" for S corporation. If it is a single-member LLC that is a disregarded entity, do not check the "Limited Liability Company" box; instead check the first box in line 3 "Individual/sole proprietor or single-member LLC."

Line 4, Exemptions

If you are exempt from backup withholding and/or FATCA reporting, enter in the appropriate space in line 4 any code(s) that may apply to you.

Exempt payee code.

- Generally, individuals (including sole proprietors) are not exempt from backup withholding.
- Except as provided below, corporations are exempt from backup withholding for certain payments, including interest and dividends.
- Corporations are not exempt from backup withholding for payments made in settlement of payment card or third party network transactions.
- Corporations are not exempt from backup withholding with respect to attorneys' fees or gross proceeds paid to attorneys, and corporations that provide medical or health care services are not exempt with respect to payments reportable on Form 1099-MISC.

The following codes identify payees that are exempt from backup withholding. Enter the appropriate code in the space in line 4.

- 1—An organization exempt from tax under section 501(a), any IRA, or a custodial account under section 403(b)(7) if the account satisfies the requirements of section 401(f)(2)
- 2—The United States or any of its agencies or instrumentalities
- 3—A state, the District of Columbia, a U.S. commonwealth or possession, or any of their political subdivisions or instrumentalities
- 4—A foreign government or any of its political subdivisions, agencies, or instrumentalities
- 5—A corporation
- 6—A dealer in securities or commodities required to register in the United States, the District of Columbia, or a U.S. commonwealth or possession
- 7—A futures commission merchant registered with the Commodity Futures Trading Commission
- 8—A real estate investment trust
- 9—An entity registered at all times during the tax year under the Investment Company Act of 1940
- 10—A common trust fund operated by a bank under section 584(a)
- 11—A financial institution
- 12—A middleman known in the investment community as a nominee or custodian
- 13—A trust exempt from tax under section 664 or described in section 4947

The following chart shows types of payments that may be exempt from backup withholding. The chart applies to the exempt payees listed above, 1 through 13.

IF the payment is for . . .	THEN the payment is exempt for . . .
Interest and dividend payments	All exempt payees except for 7
Broker transactions	Exempt payees 1 through 4 and 6 through 11 and all C corporations. S corporations must not enter an exempt payee code because they are exempt only for sales of noncovered securities acquired prior to 2012.
Barter exchange transactions and patronage dividends	Exempt payees 1 through 4
Payments over \$600 required to be reported and direct sales over \$5,000 ¹	Generally, exempt payees 1 through 5 ²
Payments made in settlement of payment card or third party network transactions	Exempt payees 1 through 4

¹ See Form 1099-MISC, Miscellaneous Income, and its instructions.

² However, the following payments made to a corporation and reportable on Form 1099-MISC are not exempt from backup withholding: medical and health care payments, attorneys' fees, gross proceeds paid to an attorney reportable under section 6045(f), and payments for services paid by a federal executive agency.

Exemption from FATCA reporting code. The following codes identify payees that are exempt from reporting under FATCA. These codes apply to persons submitting this form for accounts maintained outside of the United States by certain foreign financial institutions. Therefore, if you are only submitting this form for an account you hold in the United States, you may leave this field blank. Consult with the person requesting this form if you are uncertain if the financial institution is subject to these requirements. A requester may indicate that a code is not required by providing you with a Form W-9 with "Not Applicable" (or any similar indication) written or printed on the line for a FATCA exemption code.

- A—An organization exempt from tax under section 501(a) or any individual retirement plan as defined in section 7701(a)(37)
- B—The United States or any of its agencies or instrumentalities
- C—A state, the District of Columbia, a U.S. commonwealth or possession, or any of their political subdivisions or instrumentalities
- D—A corporation the stock of which is regularly traded on one or more established securities markets, as described in Regulations section 1.1472-1(c)(1)(i)
- E—A corporation that is a member of the same expanded affiliated group as a corporation described in Regulations section 1.1472-1(c)(1)(i)
- F—A dealer in securities, commodities, or derivative financial instruments (including notional principal contracts, futures, forwards, and options) that is registered as such under the laws of the United States or any state
- G—A real estate investment trust
- H—A regulated investment company as defined in section 851 or an entity registered at all times during the tax year under the Investment Company Act of 1940
- I—A common trust fund as defined in section 584(a)
- J—A bank as defined in section 581
- K—A broker
- L—A trust exempt from tax under section 664 or described in section 4947(a)(1)
- M—A tax exempt trust under a section 403(b) plan or section 457(g) plan

Note. You may wish to consult with the financial institution requesting this form to determine whether the FATCA code and/or exempt payee code should be completed.

Line 5

Enter your address (number, street, and apartment or suite number). This is where the requester of this Form W-9 will mail your information returns.

Line 6

Enter your city, state, and ZIP code.

Part I. Taxpayer Identification Number (TIN)

Enter your TIN in the appropriate box. If you are a resident alien and you do not have and are not eligible to get an SSN, your TIN is your IRS individual taxpayer identification number (ITIN). Enter it in the social security number box. If you do not have an ITIN, see *How to get a TIN* below.

If you are a sole proprietor and you have an EIN, you may enter either your SSN or EIN. However, the IRS prefers that you use your SSN.

If you are a single-member LLC that is disregarded as an entity separate from its owner (see *Limited Liability Company (LLC)* on this page), enter the owner's SSN (or EIN, if the owner has one). Do not enter the disregarded entity's EIN. If the LLC is classified as a corporation or partnership, enter the entity's EIN.

Note. See the chart on page 4 for further clarification of name and TIN combinations.

How to get a TIN. If you do not have a TIN, apply for one immediately. To apply for an SSN, get Form SS-5, Application for a Social Security Card, from your local SSA office or get this form online at www.ssa.gov. You may also get this form by calling 1-800-772-1213. Use Form W-7, Application for IRS Individual Taxpayer Identification Number, to apply for an ITIN, or Form SS-4, Application for Employer Identification Number, to apply for an EIN. You can apply for an EIN online by accessing the IRS website at www.irs.gov/businesses and clicking on Employer Identification Number (EIN) under Starting a Business. You can get Forms W-7 and SS-4 from the IRS by visiting IRS.gov or by calling 1-800-TAX-FORM (1-800-829-3676).

If you are asked to complete Form W-9 but do not have a TIN, apply for a TIN and write "Applied For" in the space for the TIN, sign and date the form, and give it to the requester. For interest and dividend payments, and certain payments made with respect to readily tradable instruments, generally you will have 60 days to get a TIN and give it to the requester before you are subject to backup withholding on payments. The 60-day rule does not apply to other types of payments. You will be subject to backup withholding on all such payments until you provide your TIN to the requester.

Note. Entering "Applied For" means that you have already applied for a TIN or that you intend to apply for one soon.

Caution: A disregarded U.S. entity that has a foreign owner must use the appropriate Form W-8.

Part II. Certification

To establish to the withholding agent that you are a U.S. person, or resident alien, sign Form W-9. You may be requested to sign by the withholding agent even if items 1, 4, or 5 below indicate otherwise.

For a joint account, only the person whose TIN is shown in Part I should sign (when required). In the case of a disregarded entity, the person identified on line 1 must sign. Exempt payees, see *Exempt payee code* earlier.

Signature requirements. Complete the certification as indicated in items 1 through 5 below.

1. **Interest, dividend, and barter exchange accounts opened before 1984 and broker accounts considered active during 1983.** You must give your correct TIN, but you do not have to sign the certification.
2. **Interest, dividend, broker, and barter exchange accounts opened after 1983 and broker accounts considered inactive during 1983.** You must sign the certification or backup withholding will apply. If you are subject to backup withholding and you are merely providing your correct TIN to the requester, you must cross out item 2 in the certification before signing the form.
3. **Real estate transactions.** You must sign the certification. You may cross out item 2 of the certification.
4. **Other payments.** You must give your correct TIN, but you do not have to sign the certification unless you have been notified that you have previously given an incorrect TIN. "Other payments" include payments made in the course of the requester's trade or business for rents, royalties, goods (other than bills for merchandise), medical and health care services (including payments to corporations), payments to a nonemployee for services, payments made in settlement of payment card and third party network transactions, payments to certain fishing boat crew members and fishermen, and gross proceeds paid to attorneys (including payments to corporations).
5. **Mortgage interest paid by you, acquisition or abandonment of secured property, cancellation of debt, qualified tuition program payments (under section 529), IRA, Coverdell ESA, Archer MSA or HSA contributions or distributions, and pension distributions.** You must give your correct TIN, but you do not have to sign the certification.

What Name and Number To Give the Requester

For this type of account:	Give name and SSN of:
1. Individual	The individual
2. Two or more individuals (joint account)	The actual owner of the account or, if combined funds, the first individual on the account ¹
3. Custodian account of a minor (Uniform Gift to Minors Act)	The minor ²
4. a. The usual revocable savings trust (grantor is also trustee) b. So-called trust account that is not a legal or valid trust under state law	The grantor-trustee ¹ The actual owner ¹
5. Sole proprietorship or disregarded entity owned by an individual	The owner ³
6. Grantor trust filing under Optional Form 1099 Filing Method 1 (see Regulations section 1.671-4(b)(2)(i)(A))	The grantor ⁴
For this type of account:	Give name and EIN of:
7. Disregarded entity not owned by an individual	The owner
8. A valid trust, estate, or pension trust	Legal entity ⁴
9. Corporation or LLC electing corporate status on Form 8832 or Form 2553	The corporation
10. Association, club, religious, charitable, educational, or other tax-exempt organization	The organization
11. Partnership or multi-member LLC	The partnership
12. A broker or registered nominee	The broker or nominee
13. Account with the Department of Agriculture in the name of a public entity (such as a state or local government, school district, or prison) that receives agricultural program payments	The public entity
14. Grantor trust filing under the Form 1041 Filing Method or the Optional Form 1099 Filing Method 2 (see Regulations section 1.671-4(b)(2)(i)(B))	The trust

¹ List first and circle the name of the person whose number you furnish. If only one person on a joint account has an SSN, that person's number must be furnished.
² Circle the minor's name and furnish the minor's SSN.

³ You must show your individual name and you may also enter your business or DBA name on the "Business name/disregarded entity" name line. You may use either your SSN or EIN (if you have one), but the IRS encourages you to use your SSN.
⁴ List first and circle the name of the trust, estate, or pension trust. (Do not furnish the TIN of the personal representative or trustee unless the legal entity itself is not designated in the account title.) Also see *Special rules for partnerships* on page 2.
^{*}Note. Grantor also must provide a Form W-9 to trustee of trust.

Note. If no name is circled when more than one name is listed, the number will be considered to be that of the first name listed.

Secure Your Tax Records from Identity Theft

Identity theft occurs when someone uses your personal information such as your name, SSN, or other identifying information, without your permission, to commit fraud or other crimes. An identity thief may use your SSN to get a job or may file a tax return using your SSN to receive a refund.

- To reduce your risk:
- Protect your SSN,
 - Ensure your employer is protecting your SSN, and
 - Be careful when choosing a tax preparer.

If your tax records are affected by identity theft and you receive a notice from the IRS, respond right away to the name and phone number printed on the IRS notice or letter.

If your tax records are not currently affected by identity theft but you think you are at risk due to a lost or stolen purse or wallet, questionable credit card activity or credit report, contact the IRS Identity Theft Hotline at 1-800-908-4490 or submit Form 14039.

For more information, see Publication 4535, Identity Theft Prevention and Victim Assistance.

Victims of identity theft who are experiencing economic harm or a system problem, or are seeking help in resolving tax problems that have not been resolved through normal channels, may be eligible for Taxpayer Advocate Service (TAS) assistance. You can reach TAS by calling the TAS toll-free case intake line at 1-877-777-4778 or TTY/TDD 1-800-829-4059.

Protect yourself from suspicious emails or phishing schemes. Phishing is the creation and use of email and websites designed to mimic legitimate business emails and websites. The most common act is sending an email to a user falsely claiming to be an established legitimate enterprise in an attempt to scam the user into surrendering private information that will be used for identity theft.

The IRS does not initiate contacts with taxpayers via emails. Also, the IRS does not request personal detailed information through email or ask taxpayers for the PIN numbers, passwords, or similar secret access information for their credit card, bank, or other financial accounts.

If you receive an unsolicited email claiming to be from the IRS, forward this message to phishing@irs.gov. You may also report misuse of the IRS name, logo, or other IRS property to the Treasury Inspector General for Tax Administration (TIGTA) at 1-800-368-4484. You can forward suspicious emails to the Federal Trade Commission at: spam@ftc.gov or contact them at www.ftc.gov/idtheft or 1-877-IDTHEFT (1-877-438-4338).

Visit IRS.gov to learn more about identity theft and how to reduce your risk.

Privacy Act Notice

Section 6109 of the Internal Revenue Code requires you to provide your correct TIN to persons (including federal agencies) who are required to file information returns with the IRS to report interest, dividends, or certain other income paid to you; mortgage interest you paid; the acquisition or abandonment of secured property; the cancellation of debt; or contributions you made to an IRA, Archer MSA, or HSA. The person collecting this form uses the information on the form to file information returns with the IRS, reporting the above information. Routine uses of this information include giving it to the Department of Justice for civil and criminal litigation and to cities, states, the District of Columbia, and U.S. commonwealths and possessions for use in administering their laws. The information also may be disclosed to other countries under a treaty, to federal and state agencies to enforce civil and criminal laws, or to federal law enforcement and intelligence agencies to combat terrorism. You must provide your TIN whether or not you are required to file a tax return. Under section 3406, payers must generally withhold a percentage of taxable interest, dividend, and certain other payments to a payee who does not give a TIN to the payer. Certain penalties may also apply for providing false or fraudulent information.

Job No.: _____

TAX FORM/DEBT/ RESIDENCE CERTIFICATION
(for Advertised Projects)

Taxpayer Identification Number (T.I.N.): _____

Company Name submitting Bid/Proposal: Dobie Supply, LLC.

Mailing Address: 3809 S. 2nd St. # D200, Austin TX 78704

Are you registered to do business in the State of Texas? Yes No

If you are an individual, list the names and addresses of any partnership of which you are a general partner or any assumed name(s) under which you operate your business

I. **Property:** List all taxable property in Fort Bend County owned by you or above partnerships as well as any d/b/a names. Include real and personal property as well as mineral interest accounts. (Use a second sheet of paper if necessary.)

<u>Fort Bend County Tax Acct. No.*</u>	<u>Property address or location**</u>
_____	_____
_____	_____
_____	_____
_____	_____

* This is the property account identification number assigned by the Fort Bend County Appraisal District.
 ** For real property, specify the property address or legal description. For business personal property, specify the address where the property is located. For example, office equipment will normally be at your office, but inventory may be stored at a warehouse or other location.

II. **Fort Bend County Debt** - Do you owe any debts to Fort Bend County (taxes on properties listed in I above, tickets, fines, tolls, court judgments, etc.)?
 Yes No If yes, attach a separate page explaining the debt.

III. **Residence Certification** - Pursuant to Texas Government Code §2252.001 *et seq.*, as amended, Fort Bend County requests Residence Certification. §2252.001 *et seq.* of the Government Code provides some restrictions on the awarding of governmental contracts; pertinent provisions of §2252.001 are stated below:

- (3) "Nonresident bidder" refers to a person who is not a resident.
- (4) "Resident bidder" refers to a person whose principal place of business is in this state, including a contractor whose ultimate parent company or majority owner has its principal place of business in this state.

I certify that Dobie Supply is a Resident Bidder of Texas as defined in Government Code §2252.001.
 [Company Name]

I certify that _____ is a Nonresident Bidder as defined in Government Code §2252.001 and our principal place of business is _____.
 [Company Name] [City and State]

**Fort Bend County Pricing Form
 BID 21-048
 Term Contract for Traffic Signs, Posts and Supplies**

Vendor Name:

Section 1: Complete Signs Finished traffic signs must be .080 aluminum with faces, diamond grade, VIP, reflective sheeting. Add 3M protective overlay film (series 1160) to each sign.	Estimated Annual Quantity	Bid Price per Each	Extended Cost
All way, 18 x 6, red white VIP diamond Grade (MUTCD R1-4)	400	\$5.45	\$ 2,180.00
Watch for ice on bridge, 36 x 36, hinged with closure hook, fluorescent yellow, diamond grade material	100	\$90.00	\$ 9,000.00
Type III, 12x36, fluorescent yellow, DG3, (MUTCD OM-3R)	50	\$23.00	\$ 1,150.00
Type III, 12x36, fluorescent yellow, DG3, (MUTCD OM-3L)	50	\$23.00	\$ 1,150.00
Total Section 1:			\$ 13,480.00

Vendor Name:

Section 2: Blanks Blanks must be .080 aluminum	Estimated Annual Quantity	Bid Price per Each	Extended Cost
Blanks, rounded corners, diamond punch 18 x 18	1000	NO BID	#VALUE!
Blanks, rounded corners, diamond punch 24 x 24	1000	NO BID	#VALUE!
Blanks, rounded corners, diamond punch 30 x 30	1000	NO BID	#REF!
Blanks, rounded corners, diamond punch 36 x 36	500	NO BID	#VALUE!
Blanks, octagon 30 x 30	1000	NO BID	#VALUE!
Blanks, octagon 36 x 36	300	NO BID	#VALUE!
Blanks, pentagon 30 x 30	300	NO BID	#VALUE!
Blanks, pentagon 36 x 36	65	NO BID	#VALUE!
Blanks, rounded corners, rectangle 24 x 8	400	NO BID	#VALUE!
Blanks, rounded corners, rectangle 24 x 10	400	NO BID	#VALUE!
Blanks, rounded corners, rectangle 24 x 12	400	NO BID	#VALUE!
Blanks, rounded corners, rectangle 12 x 18	400	NO BID	#VALUE!
Blanks, rounded corners, rectangle 18 x 24	400	NO BID	#VALUE!
Blanks, rounded corners, rectangle 24 x 30	1000	NO BID	#VALUE!
Blanks, rounded corners, rectangle 24 x 36	300	NO BID	#VALUE!
Blanks, rounded corners, rectangle 30 x 36	100	NO BID	#VALUE!
Blanks, rounded corners, rectangle 24 x 48	500	NO BID	#VALUE!
Blanks, rounded corners, rectangle 30 x 48	100	NO BID	#VALUE!
Blanks, rounded corners, rectangle 36 x 18	500	NO BID	#VALUE!
Blanks, rounded corners, square 18 x 18	1000	NO BID	#VALUE!
Blanks, rounded corners, square 24 x 24	1000	NO BID	#VALUE!
Blanks, rounded corners, street sign, flat, 9 x 30	600	NO BID	#VALUE!
Blanks, rounded corners, street sign, flat, 9 x 36	600	NO BID	#VALUE!
Blanks, rounded corners, street sign, flat, 9 x 42	600	NO BID	#VALUE!
Blanks, rounded corners, street sign, flat, 9 x 48	600	NO BID	#VALUE!
Blanks, round, 36" diameter	300	NO BID	#VALUE!
Blanks, rounded corners, rectangle, 10 x 30	300	NO BID	#VALUE!
Blanks, rounded corners, rectangle, 12 x 30	300	NO BID	#VALUE!
Blanks, rounded corners, triangle, 30	500	NO BID	#VALUE!
Blanks, rounded corners, triangle, 36	500	NO BID	#VALUE!
Blanks, extruded, 9 x 30	1000	NO BID	#VALUE!
Blanks, extruded, 9 x 36	1000	NO BID	#VALUE!
Blanks, extruded, 9 x 42	1000	NO BID	#VALUE!
Blanks, extruded, 9 x 48	1000	NO BID	#VALUE!
Blanks, extruded, 9 x 54	1000	NO BID	#VALUE!
Total Section 2:			#VALUE!

Vendor Name:

Section 3: Posts and Accessories- Telespar Sign Support System	Estimated Annual Quantity	Bid Price per Each	Extended Cost
12' Round 2.375 16 gauge galvanized post	500	23.00	\$ 11,500.00
14' 1-3/4"x1-3/4" square 12 gauge galvanized sign post	500	46.25	\$ 23,125.00
12" round post cap flat blade for 2.375" round post	500	9.15	\$ 4,575.00
12" round post cap extruded for 2.375" round post	500	9.15	\$ 4,575.00
**74-5606 TRF RD RW 2.375 16 gauge Post, 12'	500	\$23.00	\$ 11,500.00
75-4892 TRF RD Taper 2.875 Poz Loc Sockets	500	\$15.25	\$ 7,625.00
76-6050 6603 RD Post Shim W/9/16" Hole Wedges	500	\$4.15	\$ 2,075.00
Square sign post, 12 ft., 12 gauge, galvanized steel, pre-punched, 1-3/4" x 1-3/4"	1500	\$39.00	\$ 58,500.00
U channel galvanized steel post 7 ft. 1.12 lbs.	1500	\$10.95	\$ 16,425.00
Square post caps, 5-1/2" blade, flat with set screws	1500	\$4.00	\$ 6,000.00
Square post caps, 5-1/2" blade, extruded with set screws	1500	\$4.00	\$ 6,000.00
Round post caps for flat with set screws, 2-3/8" post OD for 5-1/2" blade	500	\$4.00	\$ 2,000.00
Round post caps for extruded with set screws, 2-3/8" post OD for 5-1/2" blade	500	\$4.00	\$ 2,000.00
Small corner bolts	4500	\$0.46	\$ 2,070.00
Flanged nuts	4500	\$0.09	\$ 405.00
Anchors: 1-7/8" x 1-7/8" x 36"	5000	\$14.25	\$ 71,250.00
Drive Rivets, 3/8" aluminum	20000	\$0.55	\$ 11,000.00
Cross brackets for street signs, 5-1/2" blade holder with set screws for flat	1000	\$4.00	\$ 4,000.00
Cross brackets for street signs, 5-1/2" blade holder with set screws for extruded	1000	\$4.00	\$ 4,000.00
Cross brackets for street signs, 12" blade holder with set screws for flat	1000	\$9.15	\$ 9,150.00
Cross brackets for street signs, 12" blade holder with set screws for extruded	1000	\$9.15	\$ 9,150.00
2-7/8" OD, rounded, for flat blades, 5-1/2" blade holder with set screws	1000	\$5.50	\$ 5,500.00
2-3/8" OD, round 12" post caps for flat blade with set screws	1000	\$9.15	\$ 9,150.00
2-3/8" OD, round 12" post caps for extruded with set screws	1000	\$9.15	\$ 9,150.00
12" blade for flat street signs, square post cap, 1-3/4"	1000	\$9.15	\$ 9,150.00
12" blade for extruded street signs, square post cap, 1-3/4"	1000	\$9.15	\$ 9,150.00
2-3/8" post clamp with fasteners included with each clamp, aluminum	1000	\$2.90	\$ 2,900.00
Total Section 3:			\$ 311,925.00

Vendor Name:

Section 4: Construction Supplies	Estimated Annual Quantity	Bid Price per Each	Extended Cost
Barricade, portable type I standard 36" plastic with reflective DG3 diamond grade sheeting with aluminum	200	\$62.50	\$ 12,500.00
Barricade, Type III collapsible, diamond grade reflective sheeting, no-maintenance plastic boards, 8 foot, double sided sheeting right and left with Telespar tubing for upright support and legs, 1" thick x 8" tall board	100	\$210.00	\$ 21,000.00
Barricade, Type III collapsible, diamond grade reflective sheeting, no-maintenance plastic boards, 10 foot, double sided sheeting right and left with Telespar tubing for upright support and legs, 1" thick x 8" tall board	100	\$285.00	\$ 28,500.00
Barricade, Type III collapsible, diamond grade reflective sheeting, no-maintenance plastic boards, 12 foot, double sided sheeting right and left with Telespar tubing for upright support and legs, 1" thick x 8" tall board	100	\$345.00	\$ 34,500.00
End of Road barricade boards, Type III with DG3 diamond grade sheeting on no-maintenance plastic boards, 10', red and white, 1" thick x 8" tall board, 3 right boards	100	\$158.00	\$ 15,800.00
End of Road barricade boards, Type III with DG3 diamond grade sheeting on no-maintenance plastic boards, 10', red and white, 1" thick x 8" tall board, 3 left boards	100	\$158.00	\$ 15,800.00
Barricade, two (2) "A" frames with two (2) 10' diamond grade sheeted I-beams, molded no-maintenance plastic boards, orange and white, right on one side and left on other side	100	\$232.50	\$ 23,250.00
Safety cones, 28", orange, 12# weight, 4" upper reflective collars, with white diamond grade VIP reflective sheeting, 14-3/4" x 14-3/4" base	100	\$24.00	\$ 2,400.00
Safety cones, 28", orange, 12# weight, 6" upper reflective collars, with white diamond grade VIP reflective sheeting, 14-3/4" x 14-3/4" base	100	\$24.00	\$ 2,400.00
Safety cones, 36", orange, 12# weight, 4" upper reflective collars, with white diamond grade VIP reflective sheeting, 14-3/4" x 14-3/4" base	100	\$25.00	\$ 2,500.00
Safety cones, 36", orange, 12# weight, 6" upper reflective collars, with white diamond grade VIP reflective sheeting, 14-3/4" x 14-3/4" base	100	\$25.00	\$ 2,500.00

Vendor Name:

Section 4: Construction Supplies (cont'd)	Estimated Annual Quantity	Bid Price per each	Extended Cost
Vertical Panel with 20" x 28" black rubber rectangular base, reflective panel 8" x 36", orange and white diagonal sheeting, double sided, diamond grade reflective sheeting,	300	\$47.75	\$ 14,325.00
Warning light, Colt RS-600, 6 volt type A	200	\$18.00	\$ 3,600.00
Warning light spring battery, general purpose 6 volt type	200	\$5.00	\$ 1,000.00
Delineator reflectors, 4" x 4", white aluminum with diamond grade sheeting	2000	\$2.24	\$ 4,480.00
Delineator reflectors, 4" x 4", fluorescent yellow aluminum with diamond grade sheeting	2000	\$2.24	\$ 4,480.00
Standard roll up construction signs, 48 x 48 reflective, vinyl, plastic corner pockets with ribs with overlays, fluorescent orange. All construction signs in the Texas Manual on Uniform Traffic Control with carrying bags	100	\$152.50	\$ 15,250.00
Standard roll up construction signs, 36 x 36 reflective, vinyl, plastic corner pockets with ribs with overlays, fluorescent orange. All construction signs in the Texas Manual on Uniform Traffic Control with carrying bags	50	\$124.00	\$ 6,200.00
DF3000W 12" Screwlock Roll-Up Sign Stand	15	\$130.00	\$ 1,950.00
DF3003W 12" Screwlock Roll-Up Sign Stand	15	\$130.00	\$ 1,950.00
DF3000S 12" Stablock Fold & Roll Sign Stand	15	\$162.50	\$ 2,437.50
DF3003S 12" Stablock Fold & Roll Sign Stand	15	\$162.50	\$ 2,437.50
DF4503 5" RUB3315 Roll-Up Sign Stand	15	\$198.00	\$ 2,970.00
DF4700TX 7" RUB3315 Roll-Up Sign Stand	15	\$220.00	\$ 3,300.00
Chip seal markers, white with cover, two sided	5000	\$0.41	\$ 2,050.00
Chip seal markers, yellow with cover, two sided	5000	\$0.41	\$ 2,050.00
Total Section 4:			\$ 229,630.00

Section 5: Carsonite Products or equal (See Section 1.18 Name Brands)	Estimated Annual Quantity	Bid Price per Each	Extended Cost
Road markers, white, Carsonite CRM-375., flexible 3.75" width x 62" length, with 3" x 12" fluorescent yellow reflective diamond grade VIP installed	1500	No Bid	#VALUE!
Total Section 5:			#VALUE!

Vendor Name:

Section 6: 3M Products	Estimated Annual Quantity	Bid Price per Each	Extended Cost
Rolls, 30", red, reflective series DG3 cubed, pressure sensitive	20	\$1,165.00	\$ 23,300.00
Rolls, 30" x 50 yd., white, engineer grade, pressure sensitive, #3200T	10	\$687.58	\$ 6,875.80
Rolls, 36" x 50 yd., white, engineer grade, pressure sensitive, #3200T	10	\$823.50	\$ 8,235.00
Rolls, 9", white, reflective, series DG3 cubed, pressure sensitive	20	\$349.50	\$ 6,990.00
Rolls, 24", white, reflective, series DG3 cubed, pressure sensitive	20	\$935.00	\$ 18,700.00
Rolls, 30", white, reflective series DG3 cubed, pressure sensitive	20	\$1,165.00	\$ 23,300.00
Rolls, 36", white, reflective series DG3 cubed, pressure sensitive	20	\$1,395.00	\$ 27,900.00
Rolls, 9", yellow, reflective, engineer grade, pressure sensitive, #3200T	5	\$205.95	\$ 1,029.75
Rolls, 9", yellow, reflective, series DG3 cubed, pressure sensitive	5	\$349.50	\$ 1,747.50
Rolls, 18", yellow, reflective, series DG3 cubed, pressure sensitive	10	\$695.00	\$ 6,950.00
Rolls, 24", yellow, reflective, series DG3 cubed, pressure sensitive	10	\$935.00	\$ 9,350.00
Rolls, 30", yellow, reflective, series DG3 cubed, pressure sensitive	10	\$1,165.00	\$ 11,650.00
Rolls, 36", yellow, reflective, series DG3 cubed, pressure sensitive	5	\$1,395.00	\$ 6,975.00
Rolls, 9", fluorescent yellow, reflective, series DG3 cubed, pressure sensitive	5	\$349.50	\$ 1,747.50
Rolls, 18", fluorescent yellow, reflective, series DG3 cubed, pressure sensitive	5	\$710.00	\$ 3,550.00
Rolls, 24", fluorescent yellow, reflective, series DG3 cubed, pressure sensitive	5	\$950.00	\$ 4,750.00
Rolls, 30", fluorescent yellow, reflective, series DG3 cubed, pressure sensitive	5	\$1,189.00	\$ 5,945.00
Rolls, 36", fluorescent yellow, reflective, series DG3 cubed, pressure sensitive	5	\$1,425.00	\$ 7,125.00
Rolls, 24", fluorescent yellow green, reflective, series DG3 cubed, pressure sensitive	5	\$950.00	\$ 4,750.00
Rolls, 30", fluorescent yellow green, reflective, series DG3 cubed, pressure sensitive	5	\$1,189.00	\$ 5,945.00

Vendor Name:

Section 6: 3M Products (cont'd)	Estimated Annual Quantity	Bid Price per Each	Extended Cost
Rolls, 18", fluorescent orange, reflective, series DG3 cubed, pressure sensitive	6	\$517.50	\$ 3,105.00
Rolls, 30", fluorescent orange, reflective, series DG3 cubed, pressure sensitive	6	\$862.50	\$ 5,175.00
Rolls, 36", fluorescent orange, reflective, series DG3 cubed, pressure sensitive	6	\$1,035.00	\$ 6,210.00
Rolls, 18", black, non-reflective, vinyl, clear synthetic	5	\$310.00	\$ 1,550.00
Rolls, 24", black, non-reflective, vinyl, clear synthetic	5	\$350.00	\$ 1,750.00
Rolls, 30", black, non-reflective, vinyl, clear synthetic	5	\$420.00	\$ 2,100.00
Rolls, 36", black, non-reflective, vinyl, clear synthetic	5	\$475.00	\$ 2,375.00
Rolls, 30", white, non-reflective, vinyl, clear synthetic	10	\$420.00	\$ 4,200.00
Rolls, 9", transfer tape, clear	60	\$81.50	\$ 4,890.00
Rolls, 12", transfer tape, clear	60	\$105.00	\$ 6,300.00
Rolls, 24", transfer tape, clear TPM5 transfer	50	\$210.00	\$ 10,500.00
Rolls, 30", transfer tape, clear TPM5	50	\$270.00	\$ 13,500.00
Rolls, 36", transfer tape, clear TPM5	50	\$320.00	\$ 16,000.00
24", E C film, brown, clear synthetic liner	6	\$380.00	\$ 2,280.00
30", E C film, brown, clear synthetic liner	6	\$475.00	\$ 2,850.00
24", E C film, green, clear synthetic liner	20	\$375.00	\$ 7,500.00
30", E C film, green, clear synthetic liner	6	\$475.00	\$ 2,850.00
24", E C film, blue, clear synthetic liner	6	\$380.00	\$ 2,280.00
30", E C film, blue, clear synthetic liner	6	\$475.00	\$ 2,850.00
24", E C film, red, clear synthetic liner	6	\$380.00	\$ 2,280.00
30", E C film, red, clear synthetic liner	6	\$475.00	\$ 2,850.00
36", E C film, red, clear synthetic liner	6	\$569.00	\$ 3,414.00
2" roll, red/white, conspicuity marking, series DG3 cubed, pressure sensitive, red/white block, 6" x 6", 983-32	6	\$99.50	\$ 597.00

Vendor Name:

Section 6: 3M Products (cont'd)	Estimated Annual Quantity	Bid Price per Each	Extended Cost
Faces (Faces only NOT complete signs, Does Not include blank) Faces must be pressure sensitive, series DG3 cubed, reflective sheeting and packaged with slip sheeting. Must be packaged with plastic washers.			
Faces: Stop ahead (symbol), 30" fluorescent yellow, series DG3 cubed, material Symbol MUTCD W3-1A	300	\$20.50	\$ 6,150.00
Faces: Stop ahead (symbol), 36" fluorescent yellow, series DG3 cubed, material Symbol MUTCD W3-1A	300	\$20.50	\$ 6,150.00
Faces: Stop sign, 30 x 30, series DG3 cubed, pre-cut corners	1000	\$29.50	\$ 29,500.00
Faces: Stop sign, 36 x 36, series DG3 cubed, pre-cut corners	300	\$18.00	\$ 5,400.00
Faces: Yield, 30 x 30	300	\$20.50	\$ 6,150.00
Faces: Signals ahead, 30 x 30 fluorescent yellow, series DG3 cubed, Symbol MUTCD W3-3	300	\$102.00	\$ 30,600.00
Faces: White body raised pavement markings, one-way white lens, 100 per carton	10	\$102.00	\$ 1,020.00
Faces: White body raised pavement markings, two-way white lens, 100 per carton	10	\$102.00	\$ 1,020.00
Faces: White body raised pavement markings, two-way white/red lens, 100 per carton	10	\$102.00	\$ 1,020.00
Faces: Yellow body raised pavement markings, one-way yellow lens, 100 per carton	10	\$102.00	\$ 1,020.00
Faces: Yellow body raised pavement markings, two-way yellow lens, 100 per carton	10	\$285.00	\$ 2,850.00
Faces: One way pressure sensitive adhesive raised pavement markers white lens, 100 per carton	10	\$285.00	\$ 2,850.00
Faces: One way pressure sensitive adhesive raised pavement markers yellow lens, 100 per carton	10	\$285.00	\$ 2,850.00
Faces: One way pressure sensitive adhesive raised pavement markers red lens, 100 per carton	10	\$285.00	\$ 2,850.00
Faces: Two way pressure sensitive adhesive raised pavement markers white lens, 100 per carton	10	\$285.00	\$ 2,850.00
Faces: Two way pressure sensitive adhesive raised pavement markers yellow lens, 100 per carton	10	\$285.00	\$ 2,850.00
3M protective overlay film (series 1160), 30" x 50 yards per roll	10	\$750.00	\$ 7,500.00
3M protective overlay film (series 1160), 36" x 50 yards per roll	10	\$800.00	\$ 8,000.00
3M citrus base cleaner (aerosol)	100	\$48.00	\$ 4,800.00

Vendor Name:

Section 6: 3M Products (cont'd)	Estimated Annual Quantity	Bid Price per Each	Extended Cost
Faces (Faces only NOT complete signs, Does Not include blank) Faces must be pressure sensitive, series DG3 cubed, reflective sheeting and packaged with slip sheeting. Must be packaged with plastic washers. Add 3M protective overlay film (series 1160) to each sign face.			
Faces: Stop ahead (symbol), 30" fluorescent yellow, series DG3 cubed, material Symbol MUTCD W3-1A	1000	\$28.00	\$ 28,000.00
Faces: Stop ahead (symbol), 36" fluorescent yellow, series DG3 cubed, material Symbol MUTCD W3-1A	1000	\$36.50	\$ 36,500.00
Faces: Stop sign, 30 x 30, series DG3 cubed, pre-cut corners	1000	\$26.00	\$ 26,000.00
Faces: Stop sign, 36 x 36, series DG3 cubed, pre-cut corners	1000	\$33.00	\$ 33,000.00
Faces: Yield, 30 x 30	1000	\$23.00	\$ 23,000.00
Faces: Yield, 36 x 36	500	\$28.00	\$ 14,000.00
Faces: Signals ahead, 30 x 30 fluorescent yellow, series DG3 cubed, Symbol MUTCD W3-3	1000	\$28.00	\$ 28,000.00
Faces: White body raised pavement markings, one-way white lens, 100 per carton	10	\$102.00	\$ 1,020.00
Faces: White body raised pavement markings, two-way white lens, 100 per carton	10	\$102.00	\$ 1,020.00
Faces: White body raised pavement markings, two-way white/red lens, 100 per carton	10	\$102.00	\$ 1,020.00
Faces: Yellow body raised pavement markings, one-way yellow lens, 100 per carton	10	\$102.00	\$ 1,020.00
Faces: Yellow body raised pavement markings, two-way yellow lens, 100 per carton	10	\$102.00	\$ 1,020.00
Faces: One way pressure sensitive adhesive raised pavement markers white lens, 100 per carton	10	\$285.00	\$ 2,850.00
Faces: One way pressure sensitive adhesive raised pavement markers yellow lens, 100 per carton	10	\$285.00	\$ 2,850.00
Faces: One way pressure sensitive adhesive raised pavement markers red lens, 100 per carton	10	\$285.00	\$ 2,850.00
Faces: Two way pressure sensitive adhesive raised pavement markers white lens, 100 per carton	10	\$285.00	\$ 2,850.00
Faces: Two way pressure sensitive adhesive raised pavement markers yellow lens, 100 per carton	10	\$285.00	\$ 2,850.00
Total Section 6:			\$ 627,501.55

Vendor Name:

Section 7: Avery-Denison	Estimated Annual Quantity	Bid Price per Each	Extended Cost
Rolls, 30" x 50 yd., white, engineer grade, pressure sensitive, #3200T	10	NO BID	#VALUE!
Rolls, 36" x 50 yd., white, engineer grade, pressure sensitive, #3200T	10	NO BID	#VALUE!
Rolls, 9", white, reflective, series DG3 cubed, pressure sensitive	20	NO BID	#VALUE!
Rolls, 24", white, reflective, series DG3 cubed, pressure sensitive	20	NO BID	#REF!
Rolls, 30", white, reflective, series DG3 cubed, pressure sensitive	20	NO BID	#VALUE!
Rolls, 36", white, reflective, series DG3 cubed, pressure sensitive	20	NO BID	#VALUE!
Rolls, 9", yellow, reflective, engineer grade, pressure sensitive, #3200T	5	NO BID	#VALUE!
Rolls, 9", yellow, reflective, series DG3 cubed, pressure sensitive	5	NO BID	#VALUE!
Rolls, 18", yellow, reflective, series DG3 cubed, pressure Sensitive	10	NO BID	#VALUE!
Rolls, 24", yellow, reflective, series DG3 cubed, pressure Sensitive	10	NO BID	#VALUE!
Rolls, 30", yellow, reflective, series DG3 cubed, pressure Sensitive	10	NO BID	#VALUE!
Rolls, 36", yellow, reflective, series DG3 cubed, pressure Sensitive	10	NO BID	#VALUE!
Rolls, 9", fluorescent yellow, reflective, series DG3 cubed, pressure sensitive	10	NO BID	#VALUE!
Rolls, 18", fluorescent yellow, reflective, series DG3 cubed, pressure sensitive	10	NO BID	#VALUE!
Rolls, 24", fluorescent yellow, reflective, series DG3 cubed, pressure sensitive	10	NO BID	#VALUE!
Rolls, 30", fluorescent yellow, reflective, series DG3 cubed, pressure sensitive	10	NO BID	#VALUE!
Rolls, 36", fluorescent yellow, reflective, series DG3 cubed, pressure sensitive	10	NO BID	#VALUE!
Rolls, 24", fluorescent yellow green, reflective, series DG3 cubed, pressure sensitive	10	NO BID	#VALUE!
Rolls, 30", fluorescent yellow green, reflective, series DG3 cubed, pressure sensitive	10	NO BID	#VALUE!
Rolls, 18", fluorescent orange, reflective, series DG3 cubed, pressure sensitive	10	NO BID	#VALUE!
Rolls, 30", fluorescent orange, reflective, series DG3 cubed, pressure sensitive	10	NO BID	#VALUE!

Vendor Name:

Section 7: Avery-Denison (cont'd)	Estimated Annual Quantity	Bid Price per Each	Extended Cost
Rolls, 36", fluorescent orange, reflective, series DG3 cubed, pressure sensitive	10	NO BID	#VALUE!
Rolls, 18", black, non-reflective, vinyl, clear synthetic	10	NO BID	#VALUE!
Rolls, 24", black, non-reflective, vinyl, clear synthetic	10	NO BID	#VALUE!
Rolls, 30", black, non-reflective, vinyl, clear synthetic	10	NO BID	#VALUE!
Rolls, 36", black, non-reflective, vinyl, clear synthetic	10	NO BID	#VALUE!
Rolls, 30", white, non-reflective, vinyl, clear synthetic	10	NO BID	#VALUE!
Rolls, 9", transfer tape, clear	60	NO BID	#VALUE!
Rolls, 12", transfer tape, clear	60	NO BID	#VALUE!
24", E C film, brown, clear synthetic liner	6	NO BID	#VALUE!
30", E C film, brown, clear synthetic liner	6	NO BID	#VALUE!
24", E C film, green, clear synthetic liner	6	NO BID	#VALUE!
30", E C film, green, clear synthetic liner	6	NO BID	#VALUE!
24", E C film, blue, clear synthetic liner	6	NO BID	#VALUE!
30", E C film, blue, clear synthetic liner	6	NO BID	#VALUE!
24", E C film, red, clear synthetic liner	6	NO BID	#VALUE!
30", E C film, red, clear synthetic liner	6	NO BID	#VALUE!
36", E C film, red, clear synthetic liner	6	NO BID	#VALUE!
2" roll, red/white, conspicuity marking, series DG3 cubed, pressure sensitive, red/white block, 6" x 6", 983-32	6	NO BID	#VALUE!

Vendor Name:

Section 7: Avery Demson (cont'd)	Estimated Annual Quantity	Bid Price per Each	Extended Cost
Faces (Faces only NOT complete signs, Does Not include blank) Faces must be pressure sensitive, series DG3 cubed, reflective sheeting and packaged with slip sheeting. Must be packaged with plastic washers.			
Faces: Stop ahead (symbol), 30" fluorescent yellow, series DG3 cubed, material Symbol MUTCD W3-1A	300	NO BID	#VALUE!
Faces: Stop sign, 30 x 30, series DG3 cubed, pre-cut corners	1000	NO BID	#VALUE!
Faces: Stop sign, 36 x 36, series DG3 cubed, pre-cut corners	300	NO BID	#VALUE!
Faces: Yield, 30 x 30	300	NO BID	#VALUE!
Faces: Signals ahead, 30 x 30 fluorescent yellow, series DG3 cubed, Symbol MUTCD W3-3	300	NO BID	#VALUE!
Faces: White body raised pavement markings, one-way white lens, 100 per carton	10	NO BID	#VALUE!
Faces: White body raised pavement markings, two-way white lens, 100 per carton	10	NO BID	#VALUE!
Faces: White body raised pavement markings, two-way white/red lens, 100 per carton	10	NO BID	#VALUE!
Faces: Yellow body raised pavement markings, one-way yellow lens, 100 per carton	10	NO BID	#VALUE!
Faces: Yellow body raised pavement markings, two-way yellow lens, 100 per carton	10	NO BID	#VALUE!
Faces: One way pressure sensitive adhesive raised pavement markers white lens, 100 per carton	10	NO BID	#VALUE!
Faces: One way pressure sensitive adhesive raised pavement markers yellow lens, 100 per carton	10	NO BID	#VALUE!
Faces: One way pressure sensitive adhesive raised pavement markers red lens, 100 per carton	10	NO BID	#VALUE!
Faces: Two way pressure sensitive adhesive raised pavement markers white lens, 100 per carton	10	NO BID	#VALUE!
Faces: Two way pressure sensitive adhesive raised pavement markers yellow lens, 100 per carton	10	NO BID	#VALUE!
Protective overlay film (series 1160), 30" x 50 yards	10	NO BID	#VALUE!
Protective overlay film (series 1160), 36" x 50 yards	10	NO BID	#VALUE!
Total Section 7:			#VALUE!

Vendor Name:

Section 8: Cutting Knives	Estimated Annual Quantity	Bid Price per Each	Extended Cost
CB09UA-5 cutting knives for Western Graphtec cutting pro 300-100	25	NO BID	#VALUE!
CB15U-5 cutting knives for Western Graphtec cutting pro 300-100	25	NO BID	#VALUE!
Total Section 8:			#VALUE!

Section 9: Banding Materials	Estimated Annual Quantity	Bid Price per Each	Extended Cost
Stainless steel, 3/4" x 100' x .030 coil in dispensing box, type 201 universal	3	NO BID	#VALUE!
3/4" wide stainless steel top split wing seal	100	NO BID	#VALUE!
Flared leg stainless sign bracket with bolt & washer	100	NO BID	#VALUE!
Total Section 9:			#VALUE!

Vendor Name:

Section 10: Safety Vests	Estimated Annual Quantity	Bid Price per Each	Extended Cost
Safetey vests, ML Kishigo Ultra-Cool mesh, contrasting #1056 (or equal), ANSI/ISEA 107 2010 Class 2 compliant, zipper front closure, 2" wide reflective material with 4.5" contrasting color, inside left chest 2-tier 4-division pencil pocket, lower right inside patch pocket, with Mic Tab on front left chest, with Road and Bridge imprinted on back, Size: M	100	\$12.90	\$ 1,290.00
Safetey vests, ML Kishigo Ultra-Cool mesh, contrasting #1056 (or equal), ANSI/ISEA 107 2010 Class 2 compliant, zipper front closure, 2" wide reflective material with 4.5" contrasting color, inside left chest 2-tier 4-division pencil pocket, lower right inside patch pocket, with Mic Tab on front left chest, with Road and Bridge imprinted on back, Size: L	100	\$12.90	\$ 1,290.00
Safetey vests, ML Kishigo Ultra-Cool mesh, contrasting #1056 (or equal), ANSI/ISEA 107 2010 Class 2 compliant, zipper front closure, 2" wide reflective material with 4.5" contrasting color, inside left chest 2-tier 4-division pencil pocket, lower right inside patch pocket, with Mic Tab on front left chest, with Road and Bridge imprinted on back, Size: XL	100	\$12.90	\$ 1,290.00
Safetey vests, ML Kishigo Ultra-Cool mesh, contrasting #1056 (or equal), ANSI/ISEA 107 2010 Class 2 compliant, zipper front closure, 2" wide reflective material with 4.5" contrasting color, inside left chest 2-tier 4-division pencil pocket, lower right inside patch pocket, with Mic Tab on front left chest, with Road and Bridge imprinted on back, Size: XXL	100	\$12.90	\$ 1,290.00
Safetey vests, ML Kishigo Ultra-Cool mesh, contrasting #1056 (or equal), ANSI/ISEA 107 2010 Class 2 compliant, zipper front closure, 2" wide reflective material with 4.5" contrasting color, inside left chest 2-tier 4-division pencil pocket, lower right inside patch pocket, with Mic Tab on front left chest, with Road and Bridge imprinted on back, Size: XXXL	100	\$12.90	\$ 1,290.00

Vendor Name:

Section 10: Safety Vests (cont'd)	Estimated Annual Quantity	Bid Price per Each	Extended Cost
Safetey vests, ML Kishigo Ultra-Cool mesh, contrasting #1056 (or equal), ANSI/ISEA 107 2010 Class 2 compliant, zipper front closure, 2" wide reflective material with 4.5" contrasting color, inside left chest 2-tier 4-division pencil pocket, lower right inside patch pocket, with Mic Tab on front left chest, with Road and Bridge imprinted on back, Size: 4XL	100	\$13.95	\$ 1,395.00
Safetey vests, ML Kishigo Ultra-Cool mesh, contrasting #1056 (or equal), ANSI/ISEA 107 2010 Class 2 compliant, zipper front closure, 2" wide reflective material with 4.5" contrasting color, inside left chest 2-tier 4-division pencil pocket, lower right inside patch pocket, with Mic Tab on front left chest, with Road and Bridge imprinted on back, Size: 5XL	100	\$13.95	\$ 1,395.00
Total Section 10:			\$ 9,240.00

Vendor Name:

Section 11: Stop/Slow Paddles	Estimated Annual Quantity	Bid Price per Each	Extended Cost
Stop/slow paddles, 24" aluminum, Diamond Grade reflective with 12" handle	10	\$88.75	\$ 887.50
Extension handles, telescopic with 2 height settings for 6' and 7' height	10	\$17.70	\$ 177.00
Total Section 11:			\$ 1,064.50

Section 12: Miscellaneous	Estimated Annual Quantity	Bid Price per Each	Extended Cost
Yellow water base traffic paint for stripping roads in	1100	\$17.25	\$ 18,975.00
White water base traffic paint for stripping roads in	1100	\$17.25	\$ 18,975.00
Blue water base traffic paint for stripping roads in gallons	1100	\$16.50	\$ 18,150.00
Red water base traffic paint for stripping roads in gallons	1100	\$16.50	\$ 18,150.00
Black water base traffic paint for stripping roads in gallons	1100	\$16.50	\$ 18,150.00
Glass beads, in pounds, 50 pounds per bag	1000	\$0.45	\$ 450.00
Bitumem adhesive for raised pavement markings in	5000	\$0.46	\$ 2,300.00
Total Section 12:			\$ 95,150.00



COUNTY PURCHASING AGENT
Fort Bend County, Texas

Vendor Information

Office (281) 341-8640

Jaime Kovar
County Purchasing Agent

Legal Company Name (top line of W9)	Newman Signs, Inc.		
Business Name (if different from legal name)	Newman Signs		
Federal ID # or S.S. #	45-0276348	DUNS #	
Type of Business	<input checked="" type="checkbox"/> Corporation/LLC <input type="checkbox"/> Sole Proprietor/Individual	<input type="checkbox"/> Partnership <input type="checkbox"/> Tax Exempt Organization	Age in Business? 61 yrs
Publicly Traded Business	<input checked="" type="checkbox"/> No <input type="checkbox"/> Yes Ticker Symbol _____		
Remittance Address	16066 th Ave SW		
City/State/Zip	Jamestown, NO 58401		
Physical Address	1606 6 th Ave SW		
City/State/Zip	Jamestown, NO 58401		
Phone/Fax Number	Phone: 800-437-9770	Fax: 701-252-9213	
Contact Person	marina Nowak		
E-mail	sales6@newmansigns.com		
Check all that apply to the company listed above and provide certification number.	DBE-Disadvantaged Business Enterprise _____	Certification # _____	
	SBE-Small Business Enterprise _____	Certification # _____	
	HUB -Texas Historically Underutilized Business _____	Certification # _____	
	WBE-Women's Business Enterprise _____	Certification # _____	
Company's gross annual receipts	<\$500,000 _____	\$500,000-\$4,999,999 <input checked="" type="checkbox"/> _____	
	\$5,000,000-\$16,999,999 _____	\$17,000,000-\$22,399,999 _____	
	>\$22,400,000 _____		
NAICs codes (Please enter all that apply)	339950		
Signature of Authorized Representative	Jennifer Schultes		
Printed Name	Jennifer Schultes		
Title	Quotation Specialist		
Date	11/15/21		

THIS FORM MUST BE SUBMITTED WITH THE SOLICITATION RESPONSE

Fort Bend County, Texas
Invitation for Bid



Term Contract for the Purchase of Traffic Signs, Posts and Supplies
BID 21-048

SUBMIT BIDS TO:

Fort Bend County
Purchasing Department
Travis Annex
301 Jackson, Suite 201
Richmond, TX 77469

Note: All correspondence must include the term
"Purchasing Department" in address to assist in
proper delivery.

SUBMIT NO LATER THAN:

Tuesday, January 19, 2021
2:00 PM (Central)

LABEL ENVELOPE:

BID 21-048
TRAFFIC SIGNS, POSTS, SUPPLIES

***ALL BIDS MUST BE RECEIVED IN AND TIME/DATE STAMPED BY THE PURCHASING OFFICE
OF FORT BEND COUNTY BEFORE THE SPECIFIED TIME/DATE STATED ABOVE.***

BIDS RECEIVED AS REQUIRED WILL THEN BE OPENED AND PUBLICLY READ.

BIDS RECEIVED AFTER THE SPECIFIED TIME, WILL BE RETURNED UNOPENED.

Results will not be given by phone.
Results will be provided to bidder in writing
after the Commissioners Court awards.

Requests for information must be in
writing and directed to:
Cheryl Krejci, CPPB
Senior Buyer
cheryl.krejci@fortbendcountytexas.gov

Vendor Responsibilities:

- Download and complete any addendums. (Addendums will be posted on the Fort Bend County website no
Later than 48 hours prior to bid opening)
- Submit response in accordance with requirements stated on the cover of this document.
- DO NOT submit responses via email or fax.

1.0 GENERAL REQUIREMENTS:

- 1.1 Read this entire document carefully. Follow all instructions. You are responsible for fulfilling all requirements and specifications. Be sure you understand them.
- 1.2 General Requirements apply to all advertised bids, however, these may be superseded, whole or in part, by the scope, special requirements, specifications, special specifications or other data contained herein.
- 1.3 Governing Law: Bidder is advised that these requirements shall be fully governed by the laws of the State of Texas and that Fort Bend County may request and rely on advice, decisions and opinions of the Attorney General of Texas and the County Attorney concerning any portion of these requirements.
- 1.4 Bid Document Completion: Fill out, initial each page, sign, and return ONE (1) complete bid document to the Fort Bend County Purchasing Department. An authorized representative of the bidder must sign the Contract Sheet. Do not complete the date at the top of the contract sheet. The bid document must be in a sealed envelope marked with the appropriate bid number and title. The contract will be binding only when signed by the County Judge, Fort Bend County and a purchase order authorizing the item(s) desired has been issued. The use of correction fluid is not acceptable and may result in the disqualification of bid. If an error is made, the bidder must draw a line through error and initial each change. All response, typed or written, information must be clear and legible.

If a pricing form in Excel is included and posted on the County's website amongst this bid document, the Vendor must download, complete and save the Excel (not a PDF of the Excel file) file of the pricing form on a CD or flash drive. The Excel file on the CD or flash drive must be downloadable by the Purchasing Department in order to copy and paste the vendor's pricing to the County's tabulation. The CD or flash drive must be labeled and included in the same sealed envelope with the respondent's completed bid document along with a printed copy of the pricing form completed by the vendor.

- 1.5 Bid Returns: Bidders must return completed bid document to the Fort Bend County Purchasing Department at 301 Jackson, Suite 201, Richmond, Texas no later than 2:00 P.M. on the date specified. Late bids will not be accepted. Bids must be submitted in a sealed envelope, addressed as follows: Fort Bend County Purchasing Agent, Travis Annex, 301 Jackson, Suite 201, Richmond, Texas 77469.
- 1.6 Governing Document: In the event of any conflict between the terms and provisions of these requirements and the specifications, the specifications shall govern. In the event of any conflict of interpretation of any part of this overall document, Fort Bend County's interpretation shall govern.

Initials of Bidder: JS

- 1.7 Addenda: No interpretation of the meaning of the drawings, specifications or other bid documents will be made to any bidder orally. All requests for such interpretations must be made in writing addressed to Ms. Cheryl Krejci, Senior Buyer, 301 Jackson, Suite 201, Richmond, Texas 77469, e-mail: cheryl.krejci@fortbendcountytexas.gov. Any and all interpretations and any supplemental instructions will be in the form of written addenda to the contract documents which will be posted on Fort Bend County's website. Addenda will **ONLY** be issued by the Fort Bend County Purchasing Agent. It is the sole responsibility of each bidder to insure receipt of any and all addenda. All addenda issued will become part of the contract documents. Bidders must sign and include addendum in the returned bid package. Deadline for submission of questions and/or clarification is **Tuesday, January 12, 2021 at 9:00 a.m. (CST)**. Requests received after the deadline will not be responded to due to the time constraints of this bid process.
- 1.8 Hold Harmless Agreement: Contractor shall indemnify and hold Fort Bend County harmless from all claims for personal injury, death and/or property damage arising from any cause whatsoever, resulting directly or indirectly from contractor's performance. Contractor shall procure and maintain, with respect to the subject matter of this bid, appropriate insurance coverage including, as a minimum, public liability and property damage with adequate limits to cover contractor's liability as may arise directly or indirectly from work performed under terms of this bid. Certification of such coverage must be provided to the County upon request.
- 1.9 Waiver of Subrogation: Bidder and bidder's insurance carrier waive any and all rights whatsoever with regard to subrogation against Fort Bend County as an indirect party to any suit arising out of personal or property damages resulting from bidder's performance under this agreement.
- 1.10 Severability: If any section, subsection, paragraph, sentence, clause, phrase or word of these requirements or the specifications shall be held invalid, such holding shall not affect the remaining portions of these requirements and the specifications and it is hereby declared that such remaining portions would have been included in these requirements and the specifications as though the invalid portion had been omitted.
- 1.11 Bonds: If this bid requires submission of bid guarantee and performance bond, there will be a separate page explaining those requirements. Bids submitted without the required bid bond or cashier's checks are not acceptable. Bond/s or cashier's check must be complete with all required signatures.
- 1.12 Taxes: Fort Bend County is exempt from all federal excise, state and local taxes unless otherwise stated in this document. Fort Bend County claims exemption from all sales and/or use taxes under Chapter 20, Title 122a, Vernon's Texas Civil Statutes, as amended. Texas Limited Sales Tax Exemption Certificates will be furnished upon written request to the Fort Bend County Purchasing Department.

Initials of Bidder: JS

- 1.13 Fiscal Funding: A multi-year lease or lease/purchase arrangement (if requested by the specifications), or any contract continuing as a result of an extension option, must include fiscal funding out. If, for any reason, funds are not appropriated to continue the lease or contract, said lease or contract shall become null and void. After expiration of the lease, leased equipment shall be removed by the bidder from the using department without penalty of any kind or form to Fort Bend County. All charges and physical activity related to delivery, installation, removal and redelivery shall be the responsibility of the bidder.
- 1.14 Pricing: Prices for all goods and/or services shall be firm for the duration of this contract and shall be stated in the bid spreadsheet. Prices shall be all inclusive. No price changes, additions, or subsequent qualifications will be honored during the course of the contract. All prices must be written in ink or typewritten. Pricing on all transportation, freight, and other charges are to be prepaid by the contractor and included in the bid prices. If there are any additional charges of any kind, other than those mentioned above, specified or unspecified, bidder MUST indicate the items required and attendant costs or forfeit the right to payment for such items.
- 1.15 Silence of Specifications: The apparent silence of specifications as to any detail, or the apparent omission from it of a detailed description concerning any point, shall be regarded as meaning that only the best commercial practice is to prevail and that only material and workmanship of the finest quality are to be used. All interpretations of specifications shall be made on the basis of this statement. The items furnished under this contract shall be new, unused of the latest product in production to commercial trade and shall be of the highest quality as to materials used and workmanship. Manufacturer furnishing these items shall be experienced in design and construction of such items and shall be an established supplier of the item bid.
- 1.16 Supplemental Materials: Bidders are responsible for including all pertinent product data in the returned bid package. Literature, brochures, data sheets, specification information, completed forms requested as part of the bid package and any other facts which may affect the evaluation and subsequent contract award should be included. Materials such as legal documents and contractual agreements, which the bidder wishes to include as a condition of the bid, must also be in the returned bid package. Failure to include all necessary and proper supplemental materials may be cause to reject the entire bid.
- 1.17 Material Safety Data Sheets: Under the "Hazardous Communication Act", commonly known as the "Texas Right To Know Act", a bidder must provide to County and using departments, with each delivery, material safety data sheets, which are, applicable to hazardous substances defined in the Act. Bidders are obligated to maintain a current, updated file in the Fort Bend County Purchasing Department. Failure of the bidder to maintain such a file will be cause to reject any bid applying thereto.

Initials of Bidder: JS

- 1.18 Name Brands: Specifications may reference name brands and model numbers. It is not the intent of Fort Bend County to restrict these bids in such cases, but to establish a desired quality level of merchandise or to meet a pre-established standard due to like existing items. Bidders may offer items of equal stature and the burden of proof of such stature rests with them. Fort Bend County shall act as sole judge in determining equality and acceptability of products offered.
- 1.19 Color Selection: Determination of colors of materials is a right reserved by the using department unless otherwise specified in the bid. Unspecified colors shall be quoted as standard colors, not colors, which require up charges or special handling. Unspecified fabrics or vinyl should be construed as medium grade. If bidder fails to get color/material approvals prior to delivery of merchandise, the using department may refuse to accept the items and demand correct shipment without penalty, subject to other legal remedies.
- 1.20 Evaluation: Evaluation shall be used as a determinant as to which bid items or services are the most efficient and/or most economical for the County. It shall be based on all factors, which have a bearing on price and performance of the items in the user environment. All bids are subject to tabulation by the Fort Bend County Purchasing Department and recommendation to Fort Bend County Commissioners Court. Compliance with all bid requirements, delivery and needs of the using department are considerations in evaluating bids. Pricing is NOT the only criteria for making a recommendation. The Fort Bend County Purchasing Department reserves the right to contact any bidder, at any time, to clarify, verify or request information with regard to any bid.
- 1.21 Inspections: Fort Bend County reserves the right to inspect any item(s) or service location for compliance with specifications and requirements and needs of the using department. If a bidder cannot furnish a sample of a bid item, where applicable, for review, or fails to satisfactorily show an ability to perform, the County can reject the bid as inadequate.
- 1.22 Testing: Fort Bend County reserves the right to test equipment, supplies, material and goods bid for quality, compliance with specifications and ability to meet the needs of the user. Demonstration units must be available for review. Should the goods or services fail to meet requirements and/or be unavailable for evaluation, the bid is subject to rejection.
- 1.23 Disqualification of Bidder: Upon signing this bid document, a bidder offering to sell supplies, materials, services, or equipment to Fort Bend County certifies that the bidder has not violated the antitrust laws of this state codified in section 15.01, et seq., Business & Commerce Code, or the federal antitrust laws, and has not communicated directly or indirectly the bid made to any competitor or any other person engaged in such line of business. Any or all bids may be rejected if the County believes that collusion exists among the bidders. Bids in which the prices are

Initials of Bidder: JS

obviously unbalanced may be rejected. If multiple bids are submitted by a bidder and after the bids are opened, one of the bids is withdrawn, the result will be that all of the bids submitted by that bidder will be withdrawn; however, nothing herein prohibits a vendor from submitting multiple bids for different products or services.

- 1.24 Awards: Fort Bend County reserves the right to award this contract on the basis of lowest and best bid in accordance with the laws of the State of Texas, to waive any formality or irregularity, to make awards to more than one bidder, to reject any or all bids. In the event the lowest dollar bidder meeting specifications is not awarded a contract, the bidder may appear before the Commissioners Court and present evidence concerning his responsibility. An award is final only upon formal execution by the Fort Bend County Commissioners Court or the Fort Bend County Purchasing Agent. Fort Bend County reserves the right to withdraw any award until execution by the proper authority.
- 1.25 Assignment: The successful vendor may not assign, sell or otherwise transfer this contract without written permission of Fort Bend County Commissioners Court.
- 1.26 Term Contracts: If the contract is intended to cover a specific time period, said time will be given in the specifications under scope.
- 1.27 Maintenance: Maintenance required for equipment bid should be available in Fort Bend County by a manufacturer authorized maintenance facility. Costs for this service shall be shown on the bid sheet as requested or on a separate sheet, as required. If Fort Bend County opts to include maintenance, it shall be so stated in the purchase order and said cost will be included. Service will commence only upon expiration of applicable warranties and should be priced accordingly.
- 1.28 Contract Obligation: Fort Bend County Commissioners Court must award the contract and the County Judge or other person authorized by the Fort Bend County Commissioners Court must sign the contract before it becomes binding on Fort Bend County or the bidders. Department heads are not authorized to sign agreements for Fort Bend County. Binding agreements shall remain in effect until all products and/or services covered by this purchase have been satisfactorily delivered and accepted.
- 1.29 Title Transfer: Title and Risk of Loss of goods shall not pass to Fort Bend County until Fort Bend County actually receives and takes possession of the goods at the point or points of delivery. Receiving times may vary with the using department. Generally, deliveries may be made between 8:30 a.m. and 4:00 p.m., Monday through Friday. Bidders are advised to consult the using department for instructions. The place of delivery shall be shown under the "Special Requirement" section of this bid document and/or on the Purchase Order as a "Ship To:" address.
- 1.30 Purchase Order and Delivery: The successful bidder shall not deliver products or

Initials of Bidder: SS

provide services without a Fort Bend County Purchase Order, signed by an authorized agent of the Fort Bend County Purchasing Department. The fastest, most reasonable delivery time shall be indicated by the bidder in the proper place on the bid sheet. Any special information concerning delivery should also be included, on a separate sheet, if necessary. All items shall be shipped F.O.B. inside delivery unless otherwise stated in the specifications. This shall be understood to include bringing merchandise to the appropriate room or place designated by the using department. Every tender or delivery of goods must fully comply with all provisions of these requirements and the specifications including time, delivery and quality. Nonconformance shall constitute a breach, which must be rectified prior to expiration of the time for performance. Failure to rectify within the performance period will be considered cause to reject future deliveries and cancellation of the contract by Fort Bend County without prejudice to other remedies provided by law. Where delivery times are critical, Fort Bend County reserves the right to award accordingly.

- 1.31 Contract Extension: Extensions may be made only by written agreement between Fort Bend County and the bidder. Any price escalations are limited to those stated by the bidder in the original bid.
- 1.32 Termination: Fort Bend County reserves the right to terminate the contract for default if Seller breaches any of the terms therein, including warranties of bidder or if the bidder becomes insolvent or commits acts of bankruptcy. Such right of termination is in addition to and not in lieu of any other remedies, which Fort Bend County may have in law or equity. Default may be construed as, but not limited to, failure to deliver the proper goods and/or services within the proper amount of time, and/or to properly perform any and all services required to Fort Bend County's satisfaction and/or to meet all other obligations and requirements. Contracts may be terminated without cause upon thirty (30) days written notice to either party unless otherwise specified.
- 1.33 Recycled Materials: Fort Bend County encourages the use of products made of recycled materials and shall give preference in purchasing to products made of recycled materials if the products meet applicable specifications as to quantity and quality. Fort Bend County will be the sole judge in determining product preference application.
- 1.34 Interlocal Participation: Additional governmental entities may purchase from this bid. Vendor agrees to accept purchase orders from those participating entities and to invoice each entity separately.
- 1.35 Escalation Clause: Successful bidder may apply for a price increase to the Fort Bend County Purchasing Agent. The County Purchasing Agent will review, and, if increase is deemed warranted, place the request on Fort Bend County's Commissioners Court agenda for their action of approval or disapproval. Approval by the County's Commissioner's Court is required. Any proposed price increase will

Initials of Bidder: JS

only be the amount increased to the vendor from his/her supplier. The price increase request must be stated on the vendor's letterhead with the bid number and name in the subject including, in columns, for each item: item description, original bid price, percent of increase, and the total cost of the original bid price including the increased dollar amount. Written documentation from the vendor's supplier of the increase notice must be provided to the Purchasing Agent at time of increase request. No application for a price increase may be submitted within the first six (6) months of this contract. Increase requests of more than 25% of the original bid price will not be considered.

- 1.36 Modifications: This instrument contains the entire Contract between the parties relating to the rights herein granted and obligations herein assumed. Any oral or written representations or modifications concerning this instrument shall be of no force and effect excepting a subsequent written modification signed by both parties hereto.

2.0 TERMS & CONDITIONS:

- 2.1 Seller to Package Goods: Seller will package goods in accordance with good commercial practice. Each delivery container shall be clearly and permanently marked as follows (a) Seller's name and address; (b) Consignee's name, address and purchase order number and the bid number if applicable; (c) Container number and total number of containers (e.g. box 1 of 4 boxes); and (d) the number of the container bearing the packing slip. Seller shall bear cost of packaging unless otherwise provided. Goods shall be suitably packed to secure lowest transportation costs and to conform to requirements of common carriers and any applicable specifications. Fort Bend County's count or weight shall be final and conclusive on shipments not accompanied by packing list.
- 2.2 Shipment Under Reservation Prohibited: Seller is not authorized to ship goods under reservation and no tender of a bill of lading will operate as a tender of goods.
- 2.3 Title and Risk of Loss: The title and risk of loss of the goods shall not pass to the County until a County employee actually receives and takes possession of the goods at the point or points of delivery.
- 2.4 Delivery Terms: F.O.B. Destination Freight Prepaid, Inside Delivery, unless delivery terms are specified otherwise on Purchase Order.
- 2.5 No Replacement of Defective Tender: Every tender or delivery of goods must fully comply with all provisions of the Purchase Order as to time of delivery, quality and the like. If a tender is made which does not fully conform, this shall constitute a breach and Seller shall not have the right to substitute a conforming tender.
- 2.6 Place of Delivery: The place of delivery shall be that set forth in the block of the

Initials of Bidder: JS

purchase order entitled "Ship To". Any change thereto shall be effective by modification as provided for in Clause number 2.20 "Modifications", hereof. The terms of this agreement are "no arrival, no sale", at the discretion of Fort Bend County.

2.7 Invoices and Payments:

2.7.1 Seller shall submit separate invoices, in duplicate. Invoices shall indicate the purchase order number and the bid number if applicable. Invoices shall be itemized and transportation charges, if any, shall be listed separately. A copy of the bill of lading, and the freight waybill when applicable should be attached to the invoice.

2.7.2 Fort Bend County's obligation is payable only and solely from funds available for the purpose of this purchase. Lack of funds shall render the order null and void to the extent funds are not available and any delivered but unpaid goods will be returned to Seller by the county.

2.7.3 Do not include Federal Excise, State, or City Sales Tax. Fort Bend County is a tax-exempt governmental entity.

2.8 Gratuities: Fort Bend County may, by written notice to the Seller, cancel any order without liability, if it is determined by the County that gratuities, in the form of entertainment, gifts, or otherwise were offered or given by the Seller, or any agent or representative of the Seller to any officer or employee of Fort Bend County with a view toward securing an order. In the event an order is canceled by the County pursuant to this provision, the County shall be entitled, in addition to any other rights and remedies, to recover or withhold the amount of the cost incurred by Seller in providing such gratuities.

2.9 Special Tools and Test Equipment: If the price stated on the face of an order includes the cost of any special tooling or special test equipment fabricated or required by Seller for the purpose of filing this order, such special tooling equipment and any process sheets related thereto shall become the property of the County and to the extent feasible shall be identified by the Seller as such.

2.10 Warranty/Price:

2.10.1 The price to be paid by the County shall be that contained in Seller's bid which Seller warrants to be no higher than Seller's current prices on orders by others for products of the kind and specification covered by an order for similar quantities under similar or like conditions and methods of purchase. In the event Seller breaches this warranty the prices of the items shall be reduced to the Seller's current prices on orders by others. Fort Bend County may cancel this contract without liability.

Initials of Bidder: SS

- 2.10.2 The Seller warrants that no person or selling agency has been employed or retained to solicit or secure any County order based upon any agreement or understanding for commission, percentage, brokerage, or contingent fee excepting bona fide employees of bona fide established commercial or selling agencies maintained by the Seller for the purpose of securing business. A breach or violation of this warranty gives the County the right, in addition to any other right or rights, to cancel this contract without liability.
- 2.11 Warranty Product: Seller shall not limit or exclude any implied warranties and any attempt to do so shall render an order voidable at the option of the County. Seller warrants that the goods furnished will conform to the specifications, drawings, and description listed in the bid invitation and purchase order as applicable, and to the sample(s) furnished by Seller if any. In the event of a conflict between the specifications, drawings, and descriptions, the specifications shall govern.
- 2.12 Safety Warranty: Seller warrants that the product sold to Fort Bend County shall conform to the standards promulgated by the U.S. Department of Labor under the Occupational Safety and Health Act of 1970. In the event the product does not conform to OSHA standards, the County may return the product for correction or replacement at the Seller's expense. In the event Seller fails to make the appropriate correction within 10 days, correction made by the County will be at Seller's expense.
- 2.13 No Warranty by Fort Bend County Against Infringements: As part of a contract for sale Seller agrees to ascertain whether goods manufactured in accordance with the specifications will give rise to the rightful claim of any third person by way of infringement. Fort Bend County makes no warranty that the production of goods according to the specification will not give rise to such a claim and in no event shall Fort Bend County be liable to Seller for indemnification in the event the Seller is sued on the grounds of infringement or the like. If Seller is of the opinion that an infringement will result, he will notify Fort Bend County to this effect in writing within two days after the receiving Purchase Order. If the County does not receive notice and is subsequently held liable for the infringement, Seller will defend and save the County harmless. If Seller in good faith ascertains that production of the goods in accordance with the specifications will result in infringement, this contract shall be null and void except that the County will pay Seller the reasonable cost of his search as to infringements.
- 2.14 Right of Inspection: The County shall have the right to inspect the goods at delivery before accepting them.
- 2.15 Cancellation: Fort Bend County shall have the right to cancel for default all or any part of the undelivered portion of an order if Seller breaches any of the terms hereof including warranties of Seller, or if the Seller becomes insolvent or files for protection under the bankruptcy laws. Such rights of cancellation are in addition to and not in lieu of any other remedies, which Fort Bend County may have in law or

Initials of Bidder: JS

equity.

2.16 Termination: The performance of work under a Purchase Order may be terminated in whole or in part by the County in accordance with this provision. Termination of work there under shall be effected by the delivery to the Seller of a "Notice of Termination" specifying the extent to which performance of work under the order is terminated and the date upon which such termination becomes effective. Such right of termination is in addition to and not in lieu of rights of Fort Bend County set forth in Clause 15 herein.

2.17 Force Majeure: Force Majeure means a delay encountered by a party in the performance of its obligations under this Agreement, which is caused by an event beyond the reasonable control of that party. Without limiting the generality of the foregoing, "Force Majeure" shall include but not be restricted to the following types of events: acts of God or public enemy; acts of governmental or regulatory authorities; fires, floods, epidemics or serious accidents; unusually severe weather conditions; strikes, lockouts, or other labor disputes; and defaults by subcontractors.

In the event of a Force Majeure, the affected party shall not be deemed to have violated its obligations under this Agreement, and the time for performance of any obligations of that party shall be extended by a period of time necessary to overcome the effects of the Force Majeure, provided that the foregoing shall not prevent this Agreement from terminating in accordance with the termination provisions. If any event constituting a Force Majeure occurs, the affected party shall notify the other parties in writing, within twenty-four (24) hours, and disclose the estimated length of delay, and cause of the delay.

2.18 Assignment-Delegation: No right or interest in an order shall be assigned or delegation of any obligation made by Seller without the written permission of Fort Bend County. Any attempted assignment or delegation by Seller shall be wholly void and totally ineffective for all purposes unless made in conformity with this paragraph.

2.19 Waiver: No claim or right arising out of a breach of any contract can be discharged in whole or in part by a waiver or renunciation of the claim or right unless the waived or renunciation is supported by consideration and is in writing signed by the aggrieved party.

2.20 Modification: A Purchase Order can be modified or rescinded only by a writing signed by both of the parties or their duly authorized agents.

2.21 Parol Evidence: This writing is intended by the parties as a final expression of their agreement and is intended also as a complete and exclusive statement of the terms of this agreement. No course of prior dealings between the parties and no usage of the trade shall be relevant to supplement or explain any terms rendered under this agreement and shall not be relevant to determine the meaning of this agreement even

Initials of Bidder: JS

though the accepting or acquiescing party has knowledge of the performance and opportunity for objection. Whenever a term defined by the Uniform Commercial Code is used in this agreement, the definition contained in the Code is to control.

- 2.22 **Applicable Law:** This agreement shall be governed by the Uniform Commercial Code. Whenever the term "Uniform Commercial Code" is used it shall be construed as meaning the Uniform Commercial Code as adopted in the State of Texas and in effective on the date of the purchase order.
- 2.23 **Advertising:** Seller shall not advertise or publish, without the County's prior consent the fact that Fort Bend County has entered into any contract, except to the extent necessary to comply with proper requests for information from an authorized representative of the federal, state, or local government.
- 2.24 **Right to Assurance:** Whenever the County in good faith has reason to question the other party's intent to perform. The County may demand that the other party give written assurance of his intent to perform. In the event that a demand is made and no assurance is given within five (5) days, the County may treat this failure as an anticipatory repudiation of the contract.
- 2.25 **Venue:** Both parties agree that venue for any litigation arising from this contract shall lie in Richmond, Fort Bend County, Texas.
- 2.26 **Prohibition Against Personal Interest in Contracts:** No officer or employee of the County shall have a financial interest, direct or indirect, in any contract with the County, or shall be financially interested, directly or indirectly, in the sale to the County of any land, materials, supplies, or service, except on behalf of the County as an officer or employee. Any willful violation of this section shall constitute malfeasance in office, and any officer or employee guilty thereof shall be subject to disciplinary action under applicable laws, statutes and codes of the State of Texas. Any violation of this section, with the knowledge, expressed or implied of the person or corporation contracting with the County shall render the contract involved voidable by the County Commissioners Court.

3.0 SCOPE:

It is the intent of Fort Bend County to contract with one (1) or more vendors to provide traffic signs, posts and supplies for Fort Bend County as specified herein.

4.0 TERM OF CONTRACT:

The term of this contract is **April 1, 2021 through March 31, 2022**, renewable annually for four (4) years (through 31 March 2026) under the same terms and conditions if mutually agreeable by both parties. Either party for any reason may terminate this contract by giving thirty (30) days written notice of the intent to terminate.

Initials of Bidder: JS

5.0 TEXAS ETHICS COMMISSION FORM 1295:

- 5.1 Effective January 1, 2016 all contracts executed by Commissioners Court, regardless of the dollar amount, will require completion of Form 1295 "Certificate of Interested Parties", per the new Government Code Statute §2252.908. All vendors submitting a response to a formal Bid, RFP, SOQ or any contracts, contract amendments, renewals or change orders are required to complete the Form 1295 online through the State of Texas Ethics Commission website. Please visit: https://www.ethics.state.tx.us/whatsnew/elf_info_form1295.htm.
- 5.2 On-line instructions:
 - 5.2.1 Name of governmental entity is to read: Fort Bend County.
 - 5.2.2 Identification number used by the governmental entity is: B21-048.
 - 5.2.3 Description is the title of the solicitation: Traffic Signs, Posts, Supplies.
- 5.3 Apparent low bidder(s) will be required to provide the Form 1295 within three (3) calendar days from notification; however, if your company is publicly traded you are not required to complete this form.

6.0 STATE LAW REQUIREMENTS FOR CONTRACTS:

The contents of this section are required by Texas Law and are included by County regardless of content.

- 6.1 Agreement to Not Boycott Israel Chapter 2270 Texas Government Code: By signature on vendor form, Contractor verifies Contractor does not boycott Israel and will not boycott Israel during the term of this Contract.
- 6.2 Texas Government Code Section 2251.152 Acknowledgment: By signature on vendor form, Contractor represents pursuant to Section 2252.152 of the Texas Government Code, that Contractor is not listed on the website of the Comptroller of the State of Texas concerning the listing of companies that are identified under Section 806.051, Section 807.051 or Section 2253.153.

7.0 HUMAN TRAFFICKING:

By acceptance of this contract, Contractor acknowledges that Fort Bend County is opposed to human trafficking and that no County funds will be used in support of services or activities that violate human trafficking laws.

Initials of Bidder: JS

8.0 ASSIGNMENT:

Contractor shall not sell, assign, transfer or convey these services, in whole or in part, without the prior written consent of Fort Bend County and as a condition of such consent, contractor shall remain liable for completion of the services in the event of default by the successor contractor or assignee.

9.0 AWARD:

This contract will be awarded to the lowest and best bidder per section.

10.0 GENERAL:

- 10.1 Quantities listed are estimates only. Fort Bend County does not guarantee the quantities stated will be purchased.
- 10.2 No minimum orders, by quantity or dollar amount.
- 10.3 Bidders may be required to submit samples for inspection and evaluation after bid opening to determine acceptability.

11.0 DELIVERY:

- 11.1 Vendor must complete delivery within thirty (30) working days after receipt of purchase order.
- 11.2 The successful bidder shall not deliver products without a Purchase Order issued by the Fort Bend County Purchasing Agent.
- 11.3 The successful bidder shall not deliver products or services in excess of those authorized and under no circumstances will Fort Bend County be liable for payment of products or services, which exceed the amounts authorized by the purchase order.
- 11.4 All orders must be delivered between 8:00 AM and 3:00 PM, Monday through Friday to the address indicated on purchase order.

12.0 SPECIFICATIONS and BID PRICING:

Specifications are located in the Excel pricing form downloadable from Fort Bend County's website. Provide bid prices in the electronic Excel file and return as stated in Section 1.4 and 1.5.

13.0 QUALITY CONTROL:

Fort Bend County reserves the right to sample and test products at time of delivery for specification compliance in the presence of the driver or vendor's representative. Costs for tests shall be borne by the Contractor in the event product fails to meet specifications. Products not in their original

Initials of Bidder: JS

Fort Bend County Bid 21-048

package will not be accepted.

14.0 REQUIRED FORMS:

All vendors submitting are required to complete and provide with submission:

- 14.1 Electronic Excel file of Pricing Form on CD or flash drive and printed hard copy
- 14.2 Vendor Form
- 14.3 W9 Form
- 14.4 Tax Form/Debt/Residence Certification

Initials of Bidder: JS

Contract Sheet
Bid 21-048

THE STATE OF TEXAS
COUNTY OF FORT BEND

This memorandum of agreement made and entered into on the 23rd day of March, 2021,
by and between Fort Bend County in the State of Texas (hereinafter designated County), acting herein by
County Judge KP George, by virtue of an order of Fort Bend County Commissioners Court, and
Newman Signs Inc. (hereinafter designated Contractor),
(company name)

WITNESSETH:

The Contractor and the County agree that the bid and specifications for the **Purchase of Traffic Signs, Posts and Supplies** which are hereto attached and made a part hereof, together with this instrument and the bond (when required) shall constitute the full agreement and contract between parties and for furnishing the items set out and described; the County agrees to pay the prices stipulated in the accepted bid.

It is further agreed that this contract shall not become binding or effective until signed by the parties hereto and a purchase order authorizing the items desired has been issued.

Executed at Richmond, Texas this 23 day of March 2021.

KP George

Fort Bend County, Texas

By: _____
County Judge KP George

County Judge, KP George

By: John Shafer
Signature of Contractor

Signature of Contractor

By: John Shafer Traffic Sales Manager
Printed Name and Title

Printed Name and Title

Request for Taxpayer Identification Number and Certification

Give Form to the
 requester. Do not
 send to the IRS.

Print or type See Specific Instructions on page 2.	1 Name (as shown on your income tax return). Name is required on this line; do not leave this line blank. Newman Signs, Inc	
	2 Business name/disregarded entity name, if different from above	
	3 Check appropriate box for federal tax classification. Check only one of the following seven boxes: <input type="checkbox"/> Individual/sole proprietor or single-member LLC <input type="checkbox"/> Limited liability company. Enter the tax classification (C=C corporation, S=S corporation, P=partnership) P- _____ Note. For a single-member LLC that is disregarded, do not check LLC; check the appropriate box in the line above for the tax classification of the single-member owner. <input type="checkbox"/> Other (see instructions) ▶	
	4 Exemptions (codes apply only to certain entities, not individuals; see instructions on page 3): Exempt payee code (if any) <u>5</u> Exemption from FATCA reporting code (if any) _____ (Applies to accounts maintained outside the US)	
	5 Address (number, street, and apt. or suite no.) 1606 6th Ave SW	Requester's name and address (optional)
	6 City, state, and ZIP code Jamestown, ND 58401	
	7 List account number(s) here (optional)	

Part I Taxpayer Identification Number (TIN)

Enter your TIN in the appropriate box. The TIN provided must match the name given on line 1 to avoid backup withholding. For individuals, this is generally your social security number (SSN). However, for a resident alien, sole proprietor, or disregarded entity, see the Part I instructions on page 3. For other entities, it is your employer identification number (EIN). If you do not have a number, see *How to get a TIN* on page 3.

Note. If the account is in more than one name, see the instructions for line 1 and the chart on page 4 for guidelines on whose number to enter.

Social security number								
OR								
Employer identification number								
4	5	-	0	2	7	6	3	4

Part II Certification

Under penalties of perjury, I certify that:

- The number shown on this form is my correct taxpayer identification number (or I am waiting for a number to be issued to me); and
- I am not subject to backup withholding because: (a) I am exempt from backup withholding, or (b) I have not been notified by the Internal Revenue Service (IRS) that I am subject to backup withholding as a result of a failure to report all interest or dividends, or (c) the IRS has notified me that I am no longer subject to backup withholding; and
- I am a U.S. citizen or other U.S. person (defined below); and
- The FATCA code(s) entered on this form (if any) indicating that I am exempt from FATCA reporting is correct.

Certification instructions. You must cross out item 2 above if you have been notified by the IRS that you are currently subject to backup withholding because you have failed to report all interest and dividends on your tax return. For real estate transactions, item 2 does not apply. For mortgage interest paid, acquisition or abandonment of secured property, cancellation of debt, contributions to an individual retirement arrangement (IRA), and generally, payments other than interest and dividends, you are not required to sign the certification, but you must provide your correct TIN. See the instructions on page 3.

Sign Here	Signature of U.S. person ▶ <i>Maria Jensen</i>	Date ▶ <i>1/22/20</i>
-----------	--	-----------------------

General Instructions

Section references are to the Internal Revenue Code unless otherwise noted.

Future developments. Information about developments affecting Form W-9 (such as legislation enacted after we release it) is at www.irs.gov/ir9.

Purpose of Form

An individual or entity (Form W-9 requester) who is required to file an information return with the IRS must obtain your correct taxpayer identification number (TIN) which may be your social security number (SSN), individual taxpayer identification number (ITIN), adoption taxpayer identification number (ATIN), or employer identification number (EIN), to report on an information return the amount paid to you, or other amount reportable on an information return. Examples of information returns include, but are not limited to, the following:

- Form 1099-INT (interest earned or paid)
- Form 1099-DIV (dividends, including those from stocks or mutual funds)
- Form 1099-MISC (various types of income, prizes, awards, or gross proceeds)
- Form 1099-B (stock or mutual fund sales and certain other transactions by brokers)
- Form 1099-S (proceeds from real estate transactions)
- Form 1099-K (merchant card and third party network transactions)

• Form 1098 (home mortgage interest), 1098-E (student loan interest), 1098-1 (tuition)

• Form 1099-C (canceled debt)

• Form 1099-A (acquisition or abandonment of secured property)

Use Form W-9 only if you are a U.S. person (including a resident alien), to provide your correct TIN.

If you do not return Form W-9 to the requester with a TIN, you might be subject to backup withholding. See *What is backup withholding?* on page 2.

By signing the filled-out form, you:

- Certify that the TIN you are giving is correct (or you are waiting for a number to be issued).
- Certify that you are not subject to backup withholding or
- Claim exemption from backup withholding if you are a U.S. exempt payee. If applicable, you are also certifying that as a U.S. person, your allocable share of any partnership income from a U.S. trade or business is not subject to the withholding tax on foreign partners' share of effectively connected income, and
- Certify that FATCA code(s) entered on this form (if any) indicating that you are exempt from the FATCA reporting, is correct. See *What is FATCA reporting?* on page 2 for further information.

Job No.: 21-048

TAX FORM/DEBT/ RESIDENCE CERTIFICATION
(for Advertised Projects)

Taxpayer Identification Number (T.I.N.): 45-0276348

Company Name submitting Bid/Proposal: Newman Signs, Inc.

Mailing Address: 1606 6th Ave SW, Jamestown, NO 58401

Are you registered to do business in the State of Texas? Yes No

If you are an individual, list the names and addresses of any partnership of which you are a general partner or any assumed name(s) under which you operate your business

N/A

I. **Property:** List all taxable property in Fort Bend County owned by you or above partnerships as well as any d/b/a names. Include real and personal property as well as mineral interest accounts. (Use a second sheet of paper if necessary.)

<u>Fort Bend County Tax Acct. No.*</u>	<u>Property address or location**</u>
<u>N/A</u>	

* This is the property account identification number assigned by the Fort Bend County Appraisal District.
** For real property, specify the property address or legal description. For business personal property, specify the address where the property is located. For example, office equipment will normally be at your office, but inventory may be stored at a warehouse or other location.

II. **Fort Bend County Debt** - Do you owe any debts to Fort Bend County (taxes on properties listed in I above, tickets, fines, tolls, court judgments, etc.)?
Yes No If yes, attach a separate page explaining the debt.

III. **Residence Certification** - Pursuant to Texas Government Code §2252.001 *et seq.*, as amended, Fort Bend County requests Residence Certification. §2252.001 *et seq.* of the Government Code provides some restrictions on the awarding of governmental contracts; pertinent provisions of §2252.001 are stated below:

- (3) "Nonresident bidder" refers to a person who is not a resident.
- (4) "Resident bidder" refers to a person whose principal place of business is in this state, including a contractor whose ultimate parent company or majority owner has its principal place of business in this state.

I certify that _____ is a Resident Bidder of Texas as defined in Government Code §2252.001.
[Company Name]

I certify that Newman Signs is a Nonresident Bidder as defined in Government Code §2252.001 and our principal place of business is Jamestown, NO.
[Company Name] [City and State]

**LEGAL NOTICE
INVITATION TO BIDDERS**

Sealed Bids will be received in the Office of Jaime Kovar, County Purchasing Agent, Fort Bend County, Travis Annex, 301 Jackson, Suite 201, Richmond, TX 77469 for the following until **TUESDAY, JANUARY 19, 2021 at 2:00 P.M. (CST)**. All bids will then be publicly opened and read in the Office of the Purchasing Agent, Travis Annex, 301 Jackson, Suite 201, Richmond, TX 77469. Bids received after the specified time will be returned unopened. All addendums will be posted on Purchasing Agent's website located at www.fortbendcountytexas.gov.

- 1. BID 21-046 – PURCHASE OF AMMUNITION**
- 2. BID 21-047 – PURCHASE OF OIL AND LUBRICANTS**
- 3. BID 21-048 – PURCHASE OF TRAFFIC SIGNS, POSTS AND SUPPLIES**
- 4. BID 21-049 – PURCHASE OF WEED, BRUSH AND INSECT CONTROL CHEMICALS**

Unit pricing required; payment will be by check. Bonds are not required. Fort Bend County reserves the right to reject any or all bids.

Signed:
Jaime Kovar, Purchasing Agent
Fort Bend County, Richmond, Texas
281-341-8640

**Fort Bend County Pricing Form
 BID 21-048
 Term Contract for Traffic Signs, Posts and Supplies**

Vendor Name: Newman Signs, Inc.

Section 1: Complete Signs Finished traffic signs must be .080 aluminum with faces, diamond grade, VIP, reflective sheeting. Add 3M protective overlay film (series 1160) to each sign.	Estimated Annual Quantity	Bid Price per Each	Extended Cost
All way, 18 x 6, red white VIP diamond Grade (MUTCD R1-4)	400	\$5.00	\$ 2,000.00
Watch for ice on bridge, 36 x 36, hinged with closure hook, fluorescent yellow, diamond grade material	100	\$85.00	\$ 8,500.00
Type III, 12x36, fluorescent yellow, DG3, (MUTCD OM-3R)	50	\$20.00	\$ 1,000.00
Type III, 12x36, fluorescent yellow, DG3, (MUTCD OM-3L)	50	\$20.00	\$ 1,000.00
Total Section 1:			\$ 12,500.00

Vendor Name: Newman Signs, Inc.

Section 2: Blanks Blanks must be .080 aluminum	Estimated Annual Quantity	Bid Price per Each	Extended Cost
Blanks, rounded corners, diamond punch 18 x 18	1000	\$5.56	\$ 5,560.00
Blanks, rounded corners, diamond punch 24 x 24	1000	\$9.89	\$ 9,890.00
Blanks, rounded corners, diamond punch 30 x 30	1000	\$15.45	\$ 15,450.00
Blanks, rounded corners, diamond punch 36 x 36	500	\$22.25	\$ 11,125.00
Blanks, octagon 30 x 30	1000	\$15.45	\$ 15,450.00
Blanks, octagon 36 x 36	300	\$22.25	\$ 6,675.00
Blanks, pentagon 30 x 30	300	\$15.45	\$ 4,635.00
Blanks, pentagon 36 x 36	65	\$22.25	\$ 1,446.25
Blanks, rounded corners, rectangle 24 x 8	400	\$3.30	\$ 1,320.00
Blanks, rounded corners, rectangle 24 x 10	400	\$4.12	\$ 1,648.00
Blanks, rounded corners, rectangle 24 x 12	400	\$4.94	\$ 1,976.00
Blanks, rounded corners, rectangle 12 x 18	400	\$3.71	\$ 1,484.00
Blanks, rounded corners, rectangle 18 x 24	400	\$7.42	\$ 2,968.00
Blanks, rounded corners, rectangle 24 x 30	1000	\$12.36	\$ 12,360.00
Blanks, rounded corners, rectangle 24 x 36	300	\$14.83	\$ 4,449.00
Blanks, rounded corners, rectangle 30 x 36	100	\$18.54	\$ 1,854.00
Blanks, rounded corners, rectangle 24 x 48	500	\$19.78	\$ 9,890.00
Blanks, rounded corners, rectangle 30 x 48	100	\$24.72	\$ 2,472.00
Blanks, rounded corners, rectangle 36 x 18	500	\$11.12	\$ 5,560.00
Blanks, rounded corners, square 18 x 18	1000	\$5.56	\$ 5,560.00
Blanks, rounded corners, square 24 x 24	1000	\$9.89	\$ 9,890.00
Blanks, rounded corners, street sign, flat, 9 x 30	600	\$4.63	\$ 2,778.00
Blanks, rounded corners, street sign, flat, 9 x 36	600	\$5.56	\$ 3,336.00
Blanks, rounded corners, street sign, flat, 9 x 42	600	\$6.49	\$ 3,894.00
Blanks, rounded corners, street sign, flat, 9 x 48	600	\$7.42	\$ 4,452.00
Blanks, round, 36" diameter	300	\$22.25	\$ 6,675.00
Blanks, rounded corners, rectangle, 10 x 30	300	\$5.15	\$ 1,545.00
Blanks, rounded corners, rectangle, 12 x 30	300	\$6.18	\$ 1,854.00
Blanks, rounded corners, triangle, 30	500	\$7.72	\$ 3,860.00
Blanks, rounded corners, triangle, 36	500	\$11.12	\$ 5,560.00
Blanks, extruded, 9 x 30	1000	\$7.46	\$ 7,460.00
Blanks, extruded, 9 x 36	1000	\$8.81	\$ 8,810.00
Blanks, extruded, 9 x 42	1000	\$10.15	\$ 10,150.00
Blanks, extruded, 9 x 48	1000	\$11.50	\$ 11,500.00
Blanks, extruded, 9 x 54	1000	\$13.50	\$ 13,500.00
Total Section 2:			\$ 217,036.25

Vendor Name: Newman Signs, Inc.

Section 3: Posts and Accessories-Telespar Sign Support System	Estimated Annual Quantity	Bid Price per Each	Extended Cost
12' Round 2.375 16 gauge galvanized post	500	NO BID	#VALUE!
14' 1-3/4"x1-3/4" square 12 gauge galvanized sign post	500	NO BID	#VALUE!
12" round post cap flat blade for 2.375" round post	500	NO BID	#VALUE!
12" round post cap extruded for 2.375" round post	500	NO BID	#VALUE!
**74-5606 TRF RD RW 2.375 16 gauge Post, 12'	500	NO BID	#VALUE!
75-4892 TRF RD Taper 2.875 Poz Loc Sockets	500	NO BID	#VALUE!
76-6050 6603 RD Post Shim W/9/16" Hole Wedges	500	NO BID	#VALUE!
Square sign post, 12 ft., 12 gauge, galvanized steel, pre-punched, 1-3/4" x 1-3/4"	1500	NO BID	#VALUE!
U channel galvanized steel post 7 ft. 1.12 lbs.	1500	NO BID	#VALUE!
Square post caps, 5-1/2" blade, flat with set screws	1500	NO BID	#VALUE!
Square post caps, 5-1/2" blade, extruded with set screws	1500	NO BID	#VALUE!
Round post caps for flat with set screws, 2-3/8" post OD for 5-1/2" blade	500	NO BID	#VALUE!
Round post caps for extruded with set screws, 2-3/8" post OD for 5-1/2" blade	500	NO BID	#VALUE!
Small corner bolts	4500	NO BID	#VALUE!
Flanged nuts	4500	NO BID	#VALUE!
Anchors: 1-7/8" x 1-7/8" x 36"	5000	NO BID	#VALUE!
Drive Rivets, 3/8" aluminum	20000	NO BID	#VALUE!
Cross brackets for street signs, 5-1/2" blade holder with set screws for flat	1000	NO BID	#VALUE!
Cross brackets for street signs, 5-1/2" blade holder with set screws for extruded	1000	NO BID	#VALUE!
Cross brackets for street signs, 12" blade holder with set screws for flat	1000	NO BID	#VALUE!
Cross brackets for street signs, 12" blade holder with set screws for extruded	1000	NO BID	#VALUE!
2-7/8" OD, rounded, for flat blades, 5-1/2" blade holder with set screws	1000	NO BID	#VALUE!
2-3/8" OD, round 12" post caps for flat blade with set screws	1000	NO BID	#VALUE!
2-3/8" OD, round 12" post caps for extruded with set screws	1000	NO BID	#VALUE!
12" blade for flat street signs, square post cap, 1-3/4"	1000	NO BID	#VALUE!
12" blade for extruded street signs, square post cap, 1-3/4"	1000	NO BID	#VALUE!
2-3/8" post clamp with fasteners included with each clamp, aluminum	1000	NO BID	#VALUE!
Total Section 3:			#VALUE!

Vendor Name: Newman Signs, Inc.

Section 4: Construction Supplies	Estimated Annual Quantity	Bid Price per Each	Extended Cost
Barricade, portable type I standard 36" plastic with reflective DG3 diamond grade sheeting with aluminum legs	200	NO BID	#VALUE!
Barricade, Type III collapsible, diamond grade reflective sheeting, no-maintenance plastic boards, 8 foot, double sided sheeting right and left with Telespar tubing for upright support and legs, 1" thick x 8" tall board	100	NO BID	#VALUE!
Barricade, Type III collapsible, diamond grade reflective sheeting, no-maintenance plastic boards, 10 foot, double sided sheeting right and left with Telespar tubing for upright support and legs, 1" thick x 8" tall board	100	NO BID	#VALUE!
Barricade, Type III collapsible, diamond grade reflective sheeting, no-maintenance plastic boards, 12 foot, double sided sheeting right and left with Telespar tubing for upright support and legs, 1" thick x 8" tall board	100	NO BID	#VALUE!
End of Road barricade boards, Type III with DG3 diamond grade sheeting on no-maintenance plastic boards, 10', red and white, 1" thick x 8" tall board, 3 right boards	100	NO BID	#VALUE!
End of Road barricade boards, Type III with DG3 diamond grade sheeting on no-maintenance plastic boards, 10', red and white, 1" thick x 8" tall board, 3 left boards	100	NO BID	#VALUE!
Barricade, two (2) "A" frames with two (2) 10' diamond grade sheeted I-beams, molded no-maintenance plastic boards, orange and white, right on one side and left on other side	100	NO BID	#VALUE!
Safety cones, 28", orange, 12# weight, 4" upper reflective collars, with white diamond grade VIP reflective sheeting, 14-3/4" x 14-3/4" base	100	NO BID	#VALUE!
Safety cones, 28", orange, 12# weight, 6" upper reflective collars, with white diamond grade VIP reflective sheeting, 14-3/4" x 14-3/4" base	100	NO BID	#VALUE!
Safety cones, 36", orange, 12# weight, 4" upper reflective collars, with white diamond grade VIP reflective sheeting, 14-3/4" x 14-3/4" base	100	NO BID	#VALUE!
Safety cones, 36", orange, 12# weight, 6" upper reflective collars, with white diamond grade VIP reflective sheeting, 14-3/4" x 14-3/4" base	100	NO BID	#VALUE!

Vendor Name: Newman Signs, Inc.

Section 4: Construction Supplies (cont'd)	Estimated Annual Quantity	Bid Price per each	Extended Cost
Vertical Panel with 20" x 28" black rubber rectangular base, reflective panel 8" x 36", orange and white diagonal sheeting, double sided, diamond grade reflective sheeting,	300	NO BID	#VALUE!
Warning light, Colt RS-600, 6 volt type A	200	NO BID	#VALUE!
Warning light spring battery, general purpose 6 volt type A	200	NO BID	#VALUE!
Delineator reflectors, 4" x 4", white aluminum with diamond grade sheeting	2000	NO BID	#VALUE!
Delineator reflectors, 4" x 4", fluorescent yellow aluminum with diamond grade sheeting	2000	NO BID	#VALUE!
Standard roll up construction signs, 48 x 48 reflective, vinyl, plastic corner pockets with ribs with overlays, fluorescent orange. All construction signs in the Texas Manual on Uniform Traffic Control with carrying bags	100	NO BID	#VALUE!
Standard roll up construction signs, 36 x 36 reflective, vinyl, plastic corner pockets with ribs with overlays, fluorescent orange. All construction signs in the Texas Manual on Uniform Traffic Control with carrying bags	50	NO BID	#VALUE!
DF3000W 12" Screwlock Roll-Up Sign Stand	15	NO BID	#VALUE!
DF3003W 12" Screwlock Roll-Up Sign Stand	15	NO BID	#VALUE!
DF3000S 12" Stablock Fold & Roll Sign Stand	15	NO BID	#VALUE!
DF3003S 12" Stablock Fold & Roll Sign Stand	15	NO BID	#VALUE!
DF4503 5" RUB3315 Roll-Up Sign Stand	15	NO BID	#VALUE!
DF4700TX 7" RUB3315 Roll-Up Sign Stand	15	NO BID	#VALUE!
Chip seal markers, white with cover, two sided	5000	NO BID	#VALUE!
Chip seal markers, yellow with cover, two sided	5000	NO BID	#VALUE!
Total Section 4:			#VALUE!

Section 5: Carsonite Products or equal (See Section 1.18 Name Brands)	Estimated Annual Quantity	Bid Price per Each	Extended Cost
Road markers, white, Carsonite CRM-375., flexible 3.75" width x 62" length, with 3" x 12" fluorescent yellow reflective diamond grade VIP installed	1500	NO BID	#VALUE!
Total Section 5:			#VALUE!

Vendor Name: Newman Signs, Inc.

Section 6: 3M Products	Estimated Annual Quantity	Bid Price per Each	Extended Cost
Rolls, 30", red, reflective series DG3 cubed, pressure sensitive	20	\$787.50	\$ 15,750.00
Rolls, 30" x 50 yd., white, engineer grade, pressure sensitive, #3200T	10	\$354.38	\$ 3,543.75
Rolls, 36" x 50 yd., white, engineer grade, pressure sensitive, #3200T	10	\$425.25	\$ 4,252.50
Rolls, 9", white, reflective, series DG3 cubed, pressure sensitive	20	\$236.25	\$ 4,725.00
Rolls, 24", white, reflective, series DG3 cubed, pressure sensitive	20	\$630.00	\$ 12,600.00
Rolls, 30", white, reflective series DG3 cubed, pressure sensitive	20	\$787.50	\$ 15,750.00
Rolls, 36", white, reflective series DG3 cubed, pressure sensitive	20	\$945.00	\$ 18,900.00
Rolls, 9", yellow, reflective, engineer grade, pressure sensitive, #3200T	5	\$106.31	\$ 531.56
Rolls, 9", yellow, reflective, series DG3 cubed, pressure sensitive	5	\$236.25	\$ 1,181.25
Rolls, 18", yellow, reflective, series DG3 cubed, pressure sensitive	10	\$472.50	\$ 4,725.00
Rolls, 24", yellow, reflective, series DG3 cubed, pressure sensitive	10	\$630.00	\$ 6,300.00
Rolls, 30", yellow, reflective, series DG3 cubed, pressure sensitive	10	\$787.50	\$ 7,875.00
Rolls, 36", yellow, reflective, series DG3 cubed, pressure sensitive	5	\$945.00	\$ 4,725.00
Rolls, 9", fluorescent yellow, reflective, series DG3 cubed, pressure sensitive	5	\$236.25	\$ 1,181.25
Rolls, 18", fluorescent yellow, reflective, series DG3 cubed, pressure sensitive	5	\$472.50	\$ 2,362.50
Rolls, 24", fluorescent yellow, reflective, series DG3 cubed, pressure sensitive	5	\$630.00	\$ 3,150.00
Rolls, 30", fluorescent yellow, reflective, series DG3 cubed, pressure sensitive	5	\$787.50	\$ 3,937.50
Rolls, 36", fluorescent yellow, reflective, series DG3 cubed, pressure sensitive	5	\$945.00	\$ 4,725.00
Rolls, 24", fluorescent yellow green, reflective, series DG3 cubed, pressure sensitive	5	\$630.00	\$ 3,150.00
Rolls, 30", fluorescent yellow green, reflective, series DG3 cubed, pressure sensitive	5	\$787.50	\$ 3,937.50

Vendor Name: Newman Signs, Inc.

Section 6: 3M Products (cont'd)	Estimated Annual Quantity	Bid Price per Each	Extended Cost
Rolls, 18", fluorescent orange, reflective, series DG3 cubed, pressure sensitive	6	\$472.50	\$ 2,835.00
Rolls, 30", fluorescent orange, reflective, series DG3 cubed, pressure sensitive	6	\$787.50	\$ 4,725.00
Rolls, 36", fluorescent orange, reflective, series DG3 cubed, pressure sensitive	6	\$945.00	\$ 5,670.00
Rolls, 18", black, non-reflective, vinyl, clear synthetic liner	5	\$141.75	\$ 708.75
Rolls, 24", black, non-reflective, vinyl, clear synthetic liner	5	\$189.00	\$ 945.00
Rolls, 30", black, non-reflective, vinyl, clear synthetic liner	5	\$236.25	\$ 1,181.25
Rolls, 36", black, non-reflective, vinyl, clear synthetic liner	5	\$283.50	\$ 1,417.50
Rolls, 30", white, non-reflective, vinyl, clear synthetic liner	10	\$236.25	\$ 2,362.50
Rolls, 9", transfer tape, clear	60	\$29.53	\$ 1,771.88
Rolls, 12", transfer tape, clear	60	\$39.38	\$ 2,362.50
Rolls, 24", transfer tape, clear TPM5 transfer	50	\$78.75	\$ 3,937.50
Rolls, 30", transfer tape, clear TPM5	50	\$98.44	\$ 4,921.88
Rolls, 36", transfer tape, clear TPM5	50	\$118.13	\$ 5,906.25
24", E C film, brown, clear synthetic liner	6	\$252.00	\$ 1,512.00
30", E C film, brown, clear synthetic liner	6	\$315.00	\$ 1,890.00
24", E C film, green, clear synthetic liner	20	\$252.00	\$ 5,040.00
30", E C film, green, clear synthetic liner	6	\$315.00	\$ 1,890.00
24", E C film, blue, clear synthetic liner	6	\$252.00	\$ 1,512.00
30", E C film, blue, clear synthetic liner	6	\$315.00	\$ 1,890.00
24", E C film, red, clear synthetic liner	6	\$252.00	\$ 1,512.00
30", E C film, red, clear synthetic liner	6	\$315.00	\$ 1,890.00
36", E C film, red, clear synthetic liner	6	\$378.00	\$ 2,268.00
2" roll, red/white, conspicuity marking, series DG3 cubed, pressure sensitive, red/white block, 6" x 6", 983-32	6	\$70.88	\$ 425.28

Vendor Name: Newman Signs, Inc.

Section 6: 3M Products (cont'd)	Estimated Annual Quantity	Bid Price per Each	Extended Cost
Faces (Faces only NOT complete signs, Does Not include blank) Faces must be pressure sensitive, series DG3 cubed, reflective sheeting and packaged with slip sheeting. Must be packaged with plastic washers.			
Faces: Stop ahead (symbol), 30" fluorescent yellow, series DG3 cubed, material Symbol MUTCD W3-1A	300	\$24.00	\$ 7,200.00
Faces: Stop ahead (symbol), 36" fluorescent yellow, series DG3 cubed, material Symbol MUTCD W3-1A	300	\$32.00	\$ 9,600.00
Faces: Stop sign, 30 x 30, series DG3 cubed, pre-cut corners	1000	\$18.75	\$ 18,750.00
Faces: Stop sign, 36 x 36, series DG3 cubed, pre-cut corners	300	\$27.00	\$ 8,100.00
Faces: Yield, 30 x 30	300	\$9.38	\$ 2,814.00
Faces: Signals ahead, 30 x 30 fluorescent yellow, series DG3 cubed, Symbol MUTCD W3-3	300	\$18.75	\$ 5,625.00
Faces: White body raised pavement markings, one-way white lens, 100 per carton	10	\$130.28	\$ 1,302.80
Faces: White body raised pavement markings, two-way white lens, 100 per carton	10	\$130.28	\$ 1,302.80
Faces: White body raised pavement markings, two-way white/red lens, 100 per carton	10	\$130.28	\$ 1,302.80
Faces: Yellow body raised pavement markings, one-way yellow lens, 100 per carton	10	\$130.28	\$ 1,302.80
Faces: Yellow body raised pavement markings, two-way yellow lens, 100 per carton	10	\$130.28	\$ 1,302.80
Faces: One way pressure sensitive adhesive raised pavement markers white lens, 100 per carton	10	\$333.04	\$ 3,330.38
Faces: One way pressure sensitive adhesive raised pavement markers yellow lens, 100 per carton	10	\$333.04	\$ 3,330.38
Faces: One way pressure sensitive adhesive raised pavement markers red lens, 100 per carton	10	\$333.04	\$ 3,330.38
Faces: Two way pressure sensitive adhesive raised pavement markers white lens, 100 per carton	10	\$333.04	\$ 3,330.38
Faces: Two way pressure sensitive adhesive raised pavement markers yellow lens, 100 per carton	10	\$333.04	\$ 3,330.38
3M protective overlay film (series 1160), 30" x 50 yards per roll	10	\$693.75	\$ 6,937.50
3M protective overlay film (series 1160), 36" x 50 yards per roll	10	\$860.63	\$ 8,606.25
3M citrus base cleaner (aerosol)	100	\$34.00	\$ 3,400.00

Vendor Name: Newman Signs, Inc.

Section 6: 3M Products (cont'd)	Estimated Annual Quantity	Bid Price per Each	Extended Cost
Faces (Faces only NOT complete signs, Does Not include blank) Faces must be pressure sensitive, series DG3 cubed, reflective sheeting and packaged with slip sheeting. Must be packaged with plastic washers. Add 3M protective overlay film (series 1160) to each sign face.			
Faces: Stop ahead (symbol), 30" fluorescent yellow, series DG3 cubed, material Symbol MUTCD W3-1A	1000	\$33.09	\$ 33,090.00
Faces: Stop ahead (symbol), 36" fluorescent yellow, series DG3 cubed, material Symbol MUTCD W3-1A	1000	\$47.66	\$ 47,660.00
Faces: Stop sign, 30 x 30, series DG3 cubed, pre-cut corners	1000	\$33.09	\$ 33,090.00
Faces: Stop sign, 36 x 36, series DG3 cubed, pre-cut corners	1000	\$47.66	\$ 47,660.00
Faces: Yield, 30 x 30	1000	\$16.55	\$ 16,550.00
Faces: Yield, 36 x 36	500	\$23.83	\$ 11,915.00
Faces: Signals ahead, 30 x 30 fluorescent yellow, series DG3 cubed, Symbol MUTCD W3-3	1000	\$33.09	\$ 33,090.00
Faces: White body raised pavement markings, one-way white lens, 100 per carton	10	\$130.28	\$ 1,302.75
Faces: White body raised pavement markings, two-way white lens, 100 per carton	10	\$130.28	\$ 1,302.75
Faces: White body raised pavement markings, two-way white/red lens, 100 per carton	10	\$130.28	\$ 1,302.75
Faces: Yellow body raised pavement markings, one-way yellow lens, 100 per carton	10	\$130.28	\$ 1,302.75
Faces: Yellow body raised pavement markings, two-way yellow lens, 100 per carton	10	\$130.28	\$ 1,302.75
Faces: One way pressure sensitive adhesive raised pavement markers white lens, 100 per carton	10	\$333.04	\$ 3,330.38
Faces: One way pressure sensitive adhesive raised pavement markers yellow lens, 100 per carton	10	\$333.04	\$ 3,330.38
Faces: One way pressure sensitive adhesive raised pavement markers red lens, 100 per carton	10	\$333.04	\$ 3,330.38
Faces: Two way pressure sensitive adhesive raised pavement markers white lens, 100 per carton	10	\$333.04	\$ 3,330.38
Faces: Two way pressure sensitive adhesive raised pavement markers yellow lens, 100 per carton	10	\$333.04	\$ 3,330.38
Total Section 6:			\$ 522,296.34

Vendor Name: Newman Signs, Inc.

Section 7: Avery Denison	Estimated Annual Quantity	Bid Price per Each	Extended Cost
Rolls, 30" x 50 yd., white, engineer grade, pressure sensitive, #3200T	10	NO BID	#VALUE!
Rolls, 36" x 50 yd., white, engineer grade, pressure sensitive, #3200T	10	NO BID	#VALUE!
Rolls, 9", white, reflective, series DG3 cubed, pressure sensitive	20	NO BID	#VALUE!
Rolls, 24", white, reflective, series DG3 cubed, pressure sensitive	20	NO BID	#VALUE!
Rolls, 30", white, reflective, series DG3 cubed, pressure sensitive	20	NO BID	#VALUE!
Rolls, 36", white, reflective, series DG3 cubed, pressure sensitive	20	NO BID	#VALUE!
Rolls, 9", yellow, reflective, engineer grade, pressure sensitive, #3200T	5	NO BID	#VALUE!
Rolls, 9", yellow, reflective, series DG3 cubed, pressure sensitive	5	NO BID	#VALUE!
Rolls, 18", yellow, reflective, series DG3 cubed, pressure Sensitive	10	NO BID	#VALUE!
Rolls, 24", yellow, reflective, series DG3 cubed, pressure Sensitive	10	NO BID	#VALUE!
Rolls, 30", yellow, reflective, series DG3 cubed, pressure Sensitive	10	NO BID	#VALUE!
Rolls, 36", yellow, reflective, series DG3 cubed, pressure Sensitive	10	NO BID	#VALUE!
Rolls, 9", fluorescent yellow, reflective, series DG3 cubed, pressure sensitive	10	NO BID	#VALUE!
Rolls, 18", fluorescent yellow, reflective, series DG3 cubed, pressure sensitive	10	NO BID	#VALUE!
Rolls, 24", fluorescent yellow, reflective, series DG3 cubed, pressure sensitive	10	NO BID	#VALUE!
Rolls, 30", fluorescent yellow, reflective, series DG3 cubed, pressure sensitive	10	NO BID	#VALUE!
Rolls, 36", fluorescent yellow, reflective, series DG3 cubed, pressure sensitive	10	NO BID	#VALUE!
Rolls, 24", fluorescent yellow green, reflective, series DG3 cubed, pressure sensitive	10	NO BID	#VALUE!
Rolls, 30", fluorescent yellow green, reflective, series DG3 cubed, pressure sensitive	10	NO BID	#VALUE!
Rolls, 18", fluorescent orange, reflective, series DG3 cubed, pressure sensitive	10	NO BID	#VALUE!
Rolls, 30", fluorescent orange, reflective, series DG3 cubed, pressure sensitive	10	NO BID	#VALUE!

Vendor Name: Newman Signs, Inc.

Section 7: Avery Denison (cont'd)	Estimated Annual Quantity	Bid Price per Each	Extended Cost
Rolls, 36", fluorescent orange, reflective, series DG3 cubed, pressure sensitive	10	NO BID	#VALUE!
Rolls, 18", black, non-reflective, vinyl, clear synthetic liner	10	NO BID	#VALUE!
Rolls, 24", black, non-reflective, vinyl, clear synthetic liner	10	NO BID	#VALUE!
Rolls, 30", black, non-reflective, vinyl, clear synthetic liner	10	NO BID	#VALUE!
Rolls, 36", black, non-reflective, vinyl, clear synthetic liner	10	NO BID	#VALUE!
Rolls, 30", white, non-reflective, vinyl, clear synthetic liner	10	NO BID	#VALUE!
Rolls, 9", transfer tape, clear	60	NO BID	#VALUE!
Rolls, 12", transfer tape, clear	60	NO BID	#VALUE!
24", E C film, brown, clear synthetic liner	6	NO BID	#VALUE!
30", E C film, brown, clear synthetic liner	6	NO BID	#VALUE!
24", E C film, green, clear synthetic liner	6	NO BID	#VALUE!
30", E C film, green, clear synthetic liner	6	NO BID	#VALUE!
24", E C film, blue, clear synthetic liner	6	NO BID	#VALUE!
30", E C film, blue, clear synthetic liner	6	NO BID	#VALUE!
24", E C film, red, clear synthetic liner	6	NO BID	#VALUE!
30", E C film, red, clear synthetic liner	6	NO BID	#VALUE!
36", E C film, red, clear synthetic liner	6	NO BID	#VALUE!
2" roll, red/white, conspicuity marking, series DG3 cubed, pressure sensitive, red/white block, 6" x 6", 983-32	6	NO BID	#VALUE!

Vendor Name: Newman Signs, Inc.

Section 7: Avery Denison (cont'd)	Estimated Annual Quantity	Bid Price per Each	Extended Cost
Faces (Faces only NOT complete signs, Does Not include blank) Faces must be pressure sensitive, series DG3 cubed, reflective sheeting and packaged with slip sheeting. Must be packaged with plastic washers.			
Faces: Stop ahead (symbol), 30" fluorescent yellow, series DG3 cubed, material Symbol MUTCD W3-1A	300	NO BID	#VALUE!
Faces: Stop sign, 30 x 30, series DG3 cubed, pre-cut corners	1000	NO BID	#VALUE!
Faces: Stop sign, 36 x 36, series DG3 cubed, pre-cut corners	300	NO BID	#VALUE!
Faces: Yield, 30 x 30	300	NO BID	#VALUE!
Faces: Signals ahead, 30 x 30 fluorescent yellow, series DG3 cubed, Symbol MUTCD W3-3	300	NO BID	#VALUE!
Faces: White body raised pavement markings, one-way white lens, 100 per carton	10	NO BID	#VALUE!
Faces: White body raised pavement markings, two-way white lens, 100 per carton	10	NO BID	#VALUE!
Faces: White body raised pavement markings, two-way white/red lens, 100 per carton	10	NO BID	#VALUE!
Faces: Yellow body raised pavement markings, one-way yellow lens, 100 per carton	10	NO BID	#VALUE!
Faces: Yellow body raised pavement markings, two-way yellow lens, 100 per carton	10	NO BID	#VALUE!
Faces: One way pressure sensitive adhesive raised pavement markers white lens, 100 per carton	10	NO BID	#VALUE!
Faces: One way pressure sensitive adhesive raised pavement markers yellow lens, 100 per carton	10	NO BID	#VALUE!
Faces: One way pressure sensitive adhesive raised pavement markers red lens, 100 per carton	10	NO BID	#VALUE!
Faces: Two way pressure sensitive adhesive raised pavement markers white lens, 100 per carton	10	NO BID	#VALUE!
Faces: Two way pressure sensitive adhesive raised pavement markers yellow lens, 100 per carton	10	NO BID	#VALUE!
Protective overlay film (series 1160), 30" x 50 yards	10	NO BID	#VALUE!
Protective overlay film (series 1160), 36" x 50 yards	10	NO BID	#VALUE!
Total Section 7:			#VALUE!

Vendor Name: Newman Signs, Inc.

Section 8: Cutting Knives	Estimated Annual Quantity	Bid Price per Each	Extended Cost
CB09UA-5 cutting knives for Western Graphtec cutting pro 300-100	25	NO BID	#VALUE!
CB15U-5 cutting knives for Western Graphtec cutting pro 300-100	25	NO BID	#VALUE!
Total Section 8:			#VALUE!

Section 9: Banding Materials	Estimated Annual Quantity	Bid Price per Each	Extended Cost
Stainless steel, 3/4" x 100' x .030 coil in dispensing box, type 201 universal	3	\$46.45	\$ 139.35
3/4" wide stainless steel top split wing seal	100	\$0.29	\$ 29.00
Flared leg stainless sign bracket with bolt & washer	100	\$1.48	\$ 148.00
Total Section 9:			\$ 316.35

Vendor Name: Newman Signs, Inc.

Section 10: Safety Vests	Estimated Annual Quantity	Bid Price per Each	Extended Cost
Safetey vests, ML Kishigo Ultra-Cool mesh, contrasting #1056 (or equal), ANSI/ISEA 107 2010 Class 2 compliant, zipper front closure, 2" wide reflective material with 4.5" contrasting color, inside left chest 2-tier 4-division pencil pocket, lower right inside patch pocket, with Mic Tab on front left chest, with Road and Bridge imprinted on back, Size: M	100	NO BID	#VALUE!
Safetey vests, ML Kishigo Ultra-Cool mesh, contrasting #1056 (or equal), ANSI/ISEA 107 2010 Class 2 compliant, zipper front closure, 2" wide reflective material with 4.5" contrasting color, inside left chest 2-tier 4-division pencil pocket, lower right inside patch pocket, with Mic Tab on front left chest, with Road and Bridge imprinted on back, Size: L	100	NO BID	#VALUE!
Safetey vests, ML Kishigo Ultra-Cool mesh, contrasting #1056 (or equal), ANSI/ISEA 107 2010 Class 2 compliant, zipper front closure, 2" wide reflective material with 4.5" contrasting color, inside left chest 2-tier 4-division pencil pocket, lower right inside patch pocket, with Mic Tab on front left chest, with Road and Bridge imprinted on back, Size: XL	100	NO BID	#VALUE!
Safetey vests, ML Kishigo Ultra-Cool mesh, contrasting #1056 (or equal), ANSI/ISEA 107 2010 Class 2 compliant, zipper front closure, 2" wide reflective material with 4.5" contrasting color, inside left chest 2-tier 4-division pencil pocket, lower right inside patch pocket, with Mic Tab on front left chest, with Road and Bridge imprinted on back, Size: XXL	100	NO BID	#VALUE!
Safetey vests, ML Kishigo Ultra-Cool mesh, contrasting #1056 (or equal), ANSI/ISEA 107 2010 Class 2 compliant, zipper front closure, 2" wide reflective material with 4.5" contrasting color, inside left chest 2-tier 4-division pencil pocket, lower right inside patch pocket, with Mic Tab on front left chest, with Road and Bridge imprinted on back, Size: XXXL	100	NO BID	#VALUE!

Vendor Name: Newman Signs, Inc.

Section 10: Safety Vests (cont'd)	Estimated Annual Quantity	Bid Price per Each	Extended Cost
Safetey vests, ML Kishigo Ultra-Cool mesh, contrasting #1056 (or equal), ANSI/ISEA 107 2010 Class 2 compliant, zipper front closure, 2" wide reflective material with 4.5" contrasting color, inside left chest 2-tier 4-division pencil pocket, lower right inside patch pocket, with Mic Tab on front left chest, with Road and Bridge imprinted on back, Size: 4XL	100	NO BID	#VALUE!
Safetey vests, ML Kishigo Ultra-Cool mesh, contrasting #1056 (or equal), ANSI/ISEA 107 2010 Class 2 compliant, zipper front closure, 2" wide reflective material with 4.5" contrasting color, inside left chest 2-tier 4-division pencil pocket, lower right inside patch pocket, with Mic Tab on front left chest, with Road and Bridge imprinted on back, Size: 5XL	100	NO BID	#VALUE!
Total Section 10:			#VALUE!

Vendor Name: Newman Signs, Inc.

Section 11: Stop/Slow Paddles	Estimated Annual Quantity	Bid Price per Each	Extended Cost
Stop/slow paddles, 24" aluminum, Diamond Grade reflective with 12" handle	10	\$106.25	\$ 1,062.50
Extension handles, telescopic with 2 height settings for 6' and 7' height	10	\$12.31	\$ 123.10
Total Section 11:			\$ 1,185.60

Section 12: Miscellaneous	Estimated Annual Quantity	Bid Price per Each	Extended Cost
Yellow water base traffic paint for stripping roads in	1100	NO BID	#VALUE!
White water base traffic paint for stripping roads in gallons	1100	NO BID	#VALUE!
Blue water base traffic paint for stripping roads in gallons	1100	NO BID	#VALUE!
Red water base traffic paint for stripping roads in gallons	1100	NO BID	#VALUE!
Black water base traffic paint for stripping roads in gallons	1100	NO BID	#VALUE!
Glass beads, in pounds, 50 pounds per bag	1000	NO BID	#VALUE!
Bitumem adhesive for raised pavement markings in pounds	5000	NO BID	#VALUE!
Total Section 12:			#VALUE!



COUNTY PURCHASING AGENT
Fort Bend County, Texas

Vendor Information

Jaime Kovar
County Purchasing Agent

Office (281) 341-8640

Legal Company Name (top line of W9)	<i>Osburn Associates, Inc.</i>		
Business Name (if different from legal name)			
Federal ID # or S.S. #	<i>31-1041388</i>	DUNS #	
Type of Business	<input checked="" type="checkbox"/> Corporation/LLC <input type="checkbox"/> Sole Proprietor/Individual	<input type="checkbox"/> Partnership <input type="checkbox"/> Tax Exempt Organization	Age in Business?
Publicly Traded Business	<input checked="" type="checkbox"/> No <input type="checkbox"/> Yes Ticker Symbol _____		
Remittance Address	<i>P.O. Box 912</i>		
City/State/Zip	<i>Logan, OH 43138</i>		
Physical Address	<i>11931 SR 93 N.</i>		
City/State/Zip	<i>Logan, OH 43138</i>		
Phone/Fax Number	Phone: <i>(800) 523-8917</i>	Fax: <i>(740) 885-8016</i>	
Contact Person	<i>Jennifer Treadway</i>		
E-mail	<i>jennifer.t@osburns.com</i>		
Check all that apply to the company listed above and provide certification number.	DBE-Disadvantaged Business Enterprise _____	Certification # _____	
	SBE-Small Business Enterprise _____	Certification # _____	
	HUB -Texas Historically Underutilized Business _____	Certification # _____	
	WBE-Women's Business Enterprise _____	Certification # _____	
Company's gross annual receipts	<\$500,000 _____	\$500,000-\$4,999,999 _____	
	\$5,000,000-\$16,999,999 <input checked="" type="checkbox"/>	\$17,000,000-\$22,399,999 _____	
	>\$22,400,000 _____		
NAICs codes (Please enter all that apply)			
Signature of Authorized Representative			
Printed Name	<i>Jennifer Treadway</i>		
Title	<i>Bidding Agent</i>		
Date	<i>1/14/2021</i>		

THIS FORM MUST BE SUBMITTED WITH THE SOLICITATION RESPONSE

*Fort Bend County, Texas
Invitation for Bid*



*Term Contract for the Purchase of Traffic Signs, Posts and Supplies
BID 21-048*

SUBMIT BIDS TO:

Fort Bend County
Purchasing Department
Travis Annex
301 Jackson, Suite 201
Richmond, TX 77469

Note: All correspondence must include the term
"Purchasing Department" in address to assist in
proper delivery.

SUBMIT NO LATER THAN:

Tuesday, January 19, 2021
2:00 PM (Central)

LABEL ENVELOPE:

BID 21-048
TRAFFIC SIGNS, POSTS, SUPPLIES

*ALL BIDS MUST BE RECEIVED IN AND TIME/DATE STAMPED BY THE PURCHASING OFFICE
OF FORT BEND COUNTY BEFORE THE SPECIFIED TIME/DATE STATED ABOVE.*

BIDS RECEIVED AS REQUIRED WILL THEN BE OPENED AND PUBLICLY READ.

BIDS RECEIVED AFTER THE SPECIFIED TIME, WILL BE RETURNED UNOPENED.

Results will not be given by phone.
Results will be provided to bidder in writing
after the Commissioners Court awards.

Requests for information must be in
writing and directed to:
Cheryl Krejci, CPPB
Senior Buyer
cheryl.krejci@fortbendcountytexas.gov

Vendor Responsibilities:

- Download and complete any addendums. (Addendums will be posted on the Fort Bend County website no
Later than 48 hours prior to bid opening)
- Submit response in accordance with requirements stated on the cover of this document.
- DO NOT submit responses via email or fax.

1.0 GENERAL REQUIREMENTS:

- 1.1 Read this entire document carefully. Follow all instructions. You are responsible for fulfilling all requirements and specifications. Be sure you understand them.
- 1.2 General Requirements apply to all advertised bids, however, these may be superseded, whole or in part, by the scope, special requirements, specifications, special specifications or other data contained herein.
- 1.3 Governing Law: Bidder is advised that these requirements shall be fully governed by the laws of the State of Texas and that Fort Bend County may request and rely on advice, decisions and opinions of the Attorney General of Texas and the County Attorney concerning any portion of these requirements.
- 1.4 Bid Document Completion: Fill out, initial each page, sign, and return ONE (1) complete bid document to the Fort Bend County Purchasing Department. An authorized representative of the bidder must sign the Contract Sheet. Do not complete the date at the top of the contract sheet. The bid document must be in a sealed envelope marked with the appropriate bid number and title. The contract will be binding only when signed by the County Judge, Fort Bend County and a purchase order authorizing the item(s) desired has been issued. The use of correction fluid is not acceptable and may result in the disqualification of bid. If an error is made, the bidder must draw a line through error and initial each change. All response, typed or written, information must be clear and legible.

If a pricing form in Excel is included and posted on the County's website amongst this bid document, the Vendor must download, complete and save the Excel (not a PDF of the Excel file) file of the pricing form on a CD or flash drive. The Excel file on the CD or flash drive must be downloadable by the Purchasing Department in order to copy and paste the vendor's pricing to the County's tabulation. The CD or flash drive must be labeled and included in the same sealed envelope with the respondent's completed bid document along with a printed copy of the pricing form completed by the vendor.

- 1.5 Bid Returns: Bidders must return completed bid document to the Fort Bend County Purchasing Department at 301 Jackson, Suite 201, Richmond, Texas no later than 2:00 P.M. on the date specified. Late bids will not be accepted. Bids must be submitted in a sealed envelope, addressed as follows: Fort Bend County Purchasing Agent, Travis Annex, 301 Jackson, Suite 201, Richmond, Texas 77469.
- 1.6 Governing Document: In the event of any conflict between the terms and provisions of these requirements and the specifications, the specifications shall govern. In the event of any conflict of interpretation of any part of this overall document, Fort Bend County's interpretation shall govern.

Initials of Bidder: JT

- 1.7 Addenda: No interpretation of the meaning of the drawings, specifications or other bid documents will be made to any bidder orally. All requests for such interpretations must be made in writing addressed to Ms. Cheryl Krejci, Senior Buyer, 301 Jackson, Suite 201, Richmond, Texas 77469, e-mail: cheryl.krejci@fortbendcountytexas.gov. Any and all interpretations and any supplemental instructions will be in the form of written addenda to the contract documents which will be posted on Fort Bend County's website. Addenda will **ONLY** be issued by the Fort Bend County Purchasing Agent. It is the sole responsibility of each bidder to insure receipt of any and all addenda. All addenda issued will become part of the contract documents. Bidders must sign and include addendum in the returned bid package. Deadline for submission of questions and/or clarification is **Tuesday, January 12, 2021 at 9:00 a.m. (CST)**. Requests received after the deadline will not be responded to due to the time constraints of this bid process.
- 1.8 Hold Harmless Agreement: Contractor shall indemnify and hold Fort Bend County harmless from all claims for personal injury, death and/or property damage arising from any cause whatsoever, resulting directly or indirectly from contractor's performance. Contractor shall procure and maintain, with respect to the subject matter of this bid, appropriate insurance coverage including, as a minimum, public liability and property damage with adequate limits to cover contractor's liability as may arise directly or indirectly from work performed under terms of this bid. Certification of such coverage must be provided to the County upon request.
- 1.9 Waiver of Subrogation: Bidder and bidder's insurance carrier waive any and all rights whatsoever with regard to subrogation against Fort Bend County as an indirect party to any suit arising out of personal or property damages resulting from bidder's performance under this agreement.
- 1.10 Severability: If any section, subsection, paragraph, sentence, clause, phrase or word of these requirements or the specifications shall be held invalid, such holding shall not affect the remaining portions of these requirements and the specifications and it is hereby declared that such remaining portions would have been included in these requirements and the specifications as though the invalid portion had been omitted.
- 1.11 Bonds: If this bid requires submission of bid guarantee and performance bond, there will be a separate page explaining those requirements. Bids submitted without the required bid bond or cashier's checks are not acceptable. Bond/s or cashier's check must be complete with all required signatures.
- 1.12 Taxes: Fort Bend County is exempt from all federal excise, state and local taxes unless otherwise stated in this document. Fort Bend County claims exemption from all sales and/or use taxes under Chapter 20, Title 122a, Vernon's Texas Civil Statutes, as amended. Texas Limited Sales Tax Exemption Certificates will be furnished upon written request to the Fort Bend County Purchasing Department.

Initials of Bidder: JT

- 1.13 Fiscal Funding: A multi-year lease or lease/purchase arrangement (if requested by the specifications), or any contract continuing as a result of an extension option, must include fiscal funding out. If, for any reason, funds are not appropriated to continue the lease or contract, said lease or contract shall become null and void. After expiration of the lease, leased equipment shall be removed by the bidder from the using department without penalty of any kind or form to Fort Bend County. All charges and physical activity related to delivery, installation, removal and redelivery shall be the responsibility of the bidder.
- 1.14 Pricing: Prices for all goods and/or services shall be firm for the duration of this contract and shall be stated in the bid spreadsheet. Prices shall be all inclusive. No price changes, additions, or subsequent qualifications will be honored during the course of the contract. All prices must be written in ink or typewritten. Pricing on all transportation, freight, and other charges are to be prepaid by the contractor and included in the bid prices. If there are any additional charges of any kind, other than those mentioned above, specified or unspecified, bidder MUST indicate the items required and attendant costs or forfeit the right to payment for such items.
- 1.15 Silence of Specifications: The apparent silence of specifications as to any detail, or the apparent omission from it of a detailed description concerning any point, shall be regarded as meaning that only the best commercial practice is to prevail and that only material and workmanship of the finest quality are to be used. All interpretations of specifications shall be made on the basis of this statement. The items furnished under this contract shall be new, unused of the latest product in production to commercial trade and shall be of the highest quality as to materials used and workmanship. Manufacturer furnishing these items shall be experienced in design and construction of such items and shall be an established supplier of the item bid.
- 1.16 Supplemental Materials: Bidders are responsible for including all pertinent product data in the returned bid package. Literature, brochures, data sheets, specification information, completed forms requested as part of the bid package and any other facts which may affect the evaluation and subsequent contract award should be included. Materials such as legal documents and contractual agreements, which the bidder wishes to include as a condition of the bid, must also be in the returned bid package. Failure to include all necessary and proper supplemental materials may be cause to reject the entire bid.
- 1.17 Material Safety Data Sheets: Under the "Hazardous Communication Act", commonly known as the "Texas Right To Know Act", a bidder must provide to County and using departments, with each delivery, material safety data sheets, which are, applicable to hazardous substances defined in the Act. Bidders are obligated to maintain a current, updated file in the Fort Bend County Purchasing Department. Failure of the bidder to maintain such a file will be cause to reject any bid applying thereto.

Initials of Bidder: JT

- 1.18 Name Brands: Specifications may reference name brands and model numbers. It is not the intent of Fort Bend County to restrict these bids in such cases, but to establish a desired quality level of merchandise or to meet a pre-established standard due to like existing items. Bidders may offer items of equal stature and the burden of proof of such stature rests with them. Fort Bend County shall act as sole judge in determining equality and acceptability of products offered.
- 1.19 Color Selection: Determination of colors of materials is a right reserved by the using department unless otherwise specified in the bid. Unspecified colors shall be quoted as standard colors, not colors, which require up charges or special handling. Unspecified fabrics or vinyl should be construed as medium grade. If bidder fails to get color/material approvals prior to delivery of merchandise, the using department may refuse to accept the items and demand correct shipment without penalty, subject to other legal remedies.
- 1.20 Evaluation: Evaluation shall be used as a determinant as to which bid items or services are the most efficient and/or most economical for the County. It shall be based on all factors, which have a bearing on price and performance of the items in the user environment. All bids are subject to tabulation by the Fort Bend County Purchasing Department and recommendation to Fort Bend County Commissioners Court. Compliance with all bid requirements, delivery and needs of the using department are considerations in evaluating bids. Pricing is NOT the only criteria for making a recommendation. The Fort Bend County Purchasing Department reserves the right to contact any bidder, at any time, to clarify, verify or request information with regard to any bid.
- 1.21 Inspections: Fort Bend County reserves the right to inspect any item(s) or service location for compliance with specifications and requirements and needs of the using department. If a bidder cannot furnish a sample of a bid item, where applicable, for review, or fails to satisfactorily show an ability to perform, the County can reject the bid as inadequate.
- 1.22 Testing: Fort Bend County reserves the right to test equipment, supplies, material and goods bid for quality, compliance with specifications and ability to meet the needs of the user. Demonstration units must be available for review. Should the goods or services fail to meet requirements and/or be unavailable for evaluation, the bid is subject to rejection.
- 1.23 Disqualification of Bidder: Upon signing this bid document, a bidder offering to sell supplies, materials, services, or equipment to Fort Bend County certifies that the bidder has not violated the antitrust laws of this state codified in section 15.01, et seq., Business & Commerce Code, or the federal antitrust laws, and has not communicated directly or indirectly the bid made to any competitor or any other person engaged in such line of business. Any or all bids may be rejected if the County believes that collusion exists among the bidders. Bids in which the prices are

Initials of Bidder: JT

obviously unbalanced may be rejected. If multiple bids are submitted by a bidder and after the bids are opened, one of the bids is withdrawn, the result will be that all of the bids submitted by that bidder will be withdrawn; however, nothing herein prohibits a vendor from submitting multiple bids for different products or services.

- 1.24 Awards: Fort Bend County reserves the right to award this contract on the basis of lowest and best bid in accordance with the laws of the State of Texas, to waive any formality or irregularity, to make awards to more than one bidder, to reject any or all bids. In the event the lowest dollar bidder meeting specifications is not awarded a contract, the bidder may appear before the Commissioners Court and present evidence concerning his responsibility. An award is final only upon formal execution by the Fort Bend County Commissioners Court or the Fort Bend County Purchasing Agent. Fort Bend County reserves the right to withdraw any award until execution by the proper authority.
- 1.25 Assignment: The successful vendor may not assign, sell or otherwise transfer this contract without written permission of Fort Bend County Commissioners Court.
- 1.26 Term Contracts: If the contract is intended to cover a specific time period, said time will be given in the specifications under scope.
- 1.27 Maintenance: Maintenance required for equipment bid should be available in Fort Bend County by a manufacturer authorized maintenance facility. Costs for this service shall be shown on the bid sheet as requested or on a separate sheet, as required. If Fort Bend County opts to include maintenance, it shall be so stated in the purchase order and said cost will be included. Service will commence only upon expiration of applicable warranties and should be priced accordingly.
- 1.28 Contract Obligation: Fort Bend County Commissioners Court must award the contract and the County Judge or other person authorized by the Fort Bend County Commissioners Court must sign the contract before it becomes binding on Fort Bend County or the bidders. Department heads are not authorized to sign agreements for Fort Bend County. Binding agreements shall remain in effect until all products and/or services covered by this purchase have been satisfactorily delivered and accepted.
- 1.29 Title Transfer: Title and Risk of Loss of goods shall not pass to Fort Bend County until Fort Bend County actually receives and takes possession of the goods at the point or points of delivery. Receiving times may vary with the using department. Generally, deliveries may be made between 8:30 a.m. and 4:00 p.m., Monday through Friday. Bidders are advised to consult the using department for instructions. The place of delivery shall be shown under the "Special Requirement" section of this bid document and/or on the Purchase Order as a "Ship To:" address.
- 1.30 Purchase Order and Delivery: The successful bidder shall not deliver products or

Initials of Bidder: JT

provide services without a Fort Bend County Purchase Order, signed by an authorized agent of the Fort Bend County Purchasing Department. The fastest, most reasonable delivery time shall be indicated by the bidder in the proper place on the bid sheet. Any special information concerning delivery should also be included, on a separate sheet, if necessary. All items shall be shipped F.O.B. inside delivery unless otherwise stated in the specifications. This shall be understood to include bringing merchandise to the appropriate room or place designated by the using department. Every tender or delivery of goods must fully comply with all provisions of these requirements and the specifications including time, delivery and quality. Nonconformance shall constitute a breach, which must be rectified prior to expiration of the time for performance. Failure to rectify within the performance period will be considered cause to reject future deliveries and cancellation of the contract by Fort Bend County without prejudice to other remedies provided by law. Where delivery times are critical, Fort Bend County reserves the right to award accordingly.

- 1.31 Contract Extension: Extensions may be made only by written agreement between Fort Bend County and the bidder. Any price escalations are limited to those stated by the bidder in the original bid.
- 1.32 Termination: Fort Bend County reserves the right to terminate the contract for default if Seller breaches any of the terms therein, including warranties of bidder or if the bidder becomes insolvent or commits acts of bankruptcy. Such right of termination is in addition to and not in lieu of any other remedies, which Fort Bend County may have in law or equity. Default may be construed as, but not limited to, failure to deliver the proper goods and/or services within the proper amount of time, and/or to properly perform any and all services required to Fort Bend County's satisfaction and/or to meet all other obligations and requirements. Contracts may be terminated without cause upon thirty (30) days written notice to either party unless otherwise specified.
- 1.33 Recycled Materials: Fort Bend County encourages the use of products made of recycled materials and shall give preference in purchasing to products made of recycled materials if the products meet applicable specifications as to quantity and quality. Fort Bend County will be the sole judge in determining product preference application.
- 1.34 Interlocal Participation: Additional governmental entities may purchase from this bid. Vendor agrees to accept purchase orders from those participating entities and to invoice each entity separately.
- 1.35 Escalation Clause: Successful bidder may apply for a price increase to the Fort Bend County Purchasing Agent. The County Purchasing Agent will review, and, if increase is deemed warranted, place the request on Fort Bend County's Commissioners Court agenda for their action of approval or disapproval. Approval by the County's Commissioner's Court is required. Any proposed price increase will

Initials of Bidder: JT

only be the amount increased to the vendor from his/her supplier. The price increase request must be stated on the vendor's letterhead with the bid number and name in the subject including, in columns, for each item: item description, original bid price, percent of increase, and the total cost of the original bid price including the increased dollar amount. Written documentation from the vendor's supplier of the increase notice must be provided to the Purchasing Agent at time of increase request. No application for a price increase may be submitted within the first six (6) months of this contract. Increase requests of more than 25% of the original bid price will not be considered.

- 1.36 Modifications: This instrument contains the entire Contract between the parties relating to the rights herein granted and obligations herein assumed. Any oral or written representations or modifications concerning this instrument shall be of no force and effect excepting a subsequent written modification signed by both parties hereto.

2.0 TERMS & CONDITIONS:

- 2.1 Seller to Package Goods: Seller will package goods in accordance with good commercial practice. Each delivery container shall be clearly and permanently marked as follows (a) Seller's name and address; (b) Consignee's name, address and purchase order number and the bid number if applicable; (c) Container number and total number of containers (e.g. box 1 of 4 boxes); and (d) the number of the container bearing the packing slip. Seller shall bear cost of packaging unless otherwise provided. Goods shall be suitably packed to secure lowest transportation costs and to conform to requirements of common carriers and any applicable specifications. Fort Bend County's count or weight shall be final and conclusive on shipments not accompanied by packing list.
- 2.2 Shipment Under Reservation Prohibited: Seller is not authorized to ship goods under reservation and no tender of a bill of lading will operate as a tender of goods.
- 2.3 Title and Risk of Loss: The title and risk of loss of the goods shall not pass to the County until a County employee actually receives and takes possession of the goods at the point or points of delivery.
- 2.4 Delivery Terms: F.O.B. Destination Freight Prepaid, Inside Delivery, unless delivery terms are specified otherwise on Purchase Order.
- 2.5 No Replacement of Defective Tender: Every tender or delivery of goods must fully comply with all provisions of the Purchase Order as to time of delivery, quality and the like. If a tender is made which does not fully conform, this shall constitute a breach and Seller shall not have the right to substitute a conforming tender.
- 2.6 Place of Delivery: The place of delivery shall be that set forth in the block of the

Initials of Bidder: JT

purchase order entitled "Ship To". Any change thereto shall be effective by modification as provided for in Clause number 2.20 "Modifications", hereof. The terms of this agreement are "no arrival, no sale", at the discretion of Fort Bend County.

2.7 Invoices and Payments:

2.7.1 Seller shall submit separate invoices, in duplicate. Invoices shall indicate the purchase order number and the bid number if applicable. Invoices shall be itemized and transportation charges, if any, shall be listed separately. A copy of the bill of lading, and the freight waybill when applicable should be attached to the invoice.

2.7.2 Fort Bend County's obligation is payable only and solely from funds available for the purpose of this purchase. Lack of funds shall render the order null and void to the extent funds are not available and any delivered but unpaid goods will be returned to Seller by the county.

2.7.3 Do not include Federal Excise, State, or City Sales Tax. Fort Bend County is a tax-exempt governmental entity.

2.8 Gratuities: Fort Bend County may, by written notice to the Seller, cancel any order without liability, if it is determined by the County that gratuities, in the form of entertainment, gifts, or otherwise were offered or given by the Seller, or any agent or representative of the Seller to any officer or employee of Fort Bend County with a view toward securing an order. In the event an order is canceled by the County pursuant to this provision, the County shall be entitled, in addition to any other rights and remedies, to recover or withhold the amount of the cost incurred by Seller in providing such gratuities.

2.9 Special Tools and Test Equipment: If the price stated on the face of an order includes the cost of any special tooling or special test equipment fabricated or required by Seller for the purpose of filing this order, such special tooling equipment and any process sheets related thereto shall become the property of the County and to the extent feasible shall be identified by the Seller as such.

2.10 Warranty/Price:

2.10.1 The price to be paid by the County shall be that contained in Seller's bid which Seller warrants to be no higher than Seller's current prices on orders by others for products of the kind and specification covered by an order for similar quantities under similar or like conditions and methods of purchase. In the event Seller breaches this warranty the prices of the items shall be reduced to the Seller's current prices on orders by others. Fort Bend County may cancel this contract without liability.

Initials of Bidder: JT

- 2.10.2 The Seller warrants that no person or selling agency has been employed or retained to solicit or secure any County order based upon any agreement or understanding for commission, percentage, brokerage, or contingent fee excepting bona fide employees of bona fide established commercial or selling agencies maintained by the Seller for the purpose of securing business. A breach or violation of this warranty gives the County the right, in addition to any other right or rights, to cancel this contract without liability.
- 2.11 **Warranty Product:** Seller shall not limit or exclude any implied warranties and any attempt to do so shall render an order voidable at the option of the County. Seller warrants that the goods furnished will conform to the specifications, drawings, and description listed in the bid invitation and purchase order as applicable, and to the sample(s) furnished by Seller if any. In the event of a conflict between the specifications, drawings, and descriptions, the specifications shall govern.
- 2.12 **Safety Warranty:** Seller warrants that the product sold to Fort Bend County shall conform to the standards promulgated by the U.S. Department of Labor under the Occupational Safety and Health Act of 1970. In the event the product does not conform to OSHA standards, the County may return the product for correction or replacement at the Seller's expense. In the event Seller fails to make the appropriate correction within 10 days, correction made by the County will be at Seller's expense.
- 2.13 **No Warranty by Fort Bend County Against Infringements:** As part of a contract for sale Seller agrees to ascertain whether goods manufactured in accordance with the specifications will give rise to the rightful claim of any third person by way of infringement. Fort Bend County makes no warranty that the production of goods according to the specification will not give rise to such a claim and in no event shall Fort Bend County be liable to Seller for indemnification in the event the Seller is sued on the grounds of infringement or the like. If Seller is of the opinion that an infringement will result, he will notify Fort Bend County to this effect in writing within two days after the receiving Purchase Order. If the County does not receive notice and is subsequently held liable for the infringement, Seller will defend and save the County harmless. If Seller in good faith ascertains that production of the goods in accordance with the specifications will result in infringement, this contract shall be null and void except that the County will pay Seller the reasonable cost of his search as to infringements.
- 2.14 **Right of Inspection:** The County shall have the right to inspect the goods at delivery before accepting them.
- 2.15 **Cancellation:** Fort Bend County shall have the right to cancel for default all or any part of the undelivered portion of an order if Seller breaches any of the terms hereof including warranties of Seller, or if the Seller becomes insolvent or files for protection under the bankruptcy laws. Such rights of cancellation are in addition to and not in lieu of any other remedies, which Fort Bend County may have in law or

Initials of Bidder: JT

equity.

- 2.16 Termination: The performance of work under a Purchase Order may be terminated in whole or in part by the County in accordance with this provision. Termination of work there under shall be effected by the delivery to the Seller of a "Notice of Termination" specifying the extent to which performance of work under the order is terminated and the date upon which such termination becomes effective. Such right of termination is in addition to and not in lieu of rights of Fort Bend County set forth in Clause 15 herein.
- 2.17 Force Majeure: Force Majeure means a delay encountered by a party in the performance of its obligations under this Agreement, which is caused by an event beyond the reasonable control of that party. Without limiting the generality of the foregoing, "Force Majeure" shall include but not be restricted to the following types of events: acts of God or public enemy; acts of governmental or regulatory authorities; fires, floods, epidemics or serious accidents; unusually severe weather conditions; strikes, lockouts, or other labor disputes; and defaults by subcontractors.
- In the event of a Force Majeure, the affected party shall not be deemed to have violated its obligations under this Agreement, and the time for performance of any obligations of that party shall be extended by a period of time necessary to overcome the effects of the Force Majeure, provided that the foregoing shall not prevent this Agreement from terminating in accordance with the termination provisions. If any event constituting a Force Majeure occurs, the affected party shall notify the other parties in writing, within twenty-four (24) hours, and disclose the estimated length of delay, and cause of the delay.
- 2.18 Assignment-Delegation: No right or interest in an order shall be assigned or delegation of any obligation made by Seller without the written permission of Fort Bend County. Any attempted assignment or delegation by Seller shall be wholly void and totally ineffective for all purposes unless made in conformity with this paragraph.
- 2.19 Waiver: No claim or right arising out of a breach of any contract can be discharged in whole or in part by a waiver or renunciation of the claim or right unless the waived or renunciation is supported by consideration and is in writing signed by the aggrieved party.
- 2.20 Modification: A Purchase Order can be modified or rescinded only by a writing signed by both of the parties or their duly authorized agents.
- 2.21 Parol Evidence: This writing is intended by the parties as a final expression of their agreement and is intended also as a complete and exclusive statement of the terms of this agreement. No course of prior dealings between the parties and no usage of the trade shall be relevant to supplement or explain any terms rendered under this agreement and shall not be relevant to determine the meaning of this agreement even

Initials of Bidder: ST

though the accepting or acquiescing party has knowledge of the performance and opportunity for objection. Whenever a term defined by the Uniform Commercial Code is used in this agreement, the definition contained in the Code is to control.

- 2.22 **Applicable Law:** This agreement shall be governed by the Uniform Commercial Code. Whenever the term "Uniform Commercial Code" is used it shall be construed as meaning the Uniform Commercial Code as adopted in the State of Texas and in effective on the date of the purchase order.
- 2.23 **Advertising:** Seller shall not advertise or publish, without the County's prior consent the fact that Fort Bend County has entered into any contract, except to the extent necessary to comply with proper requests for information from an authorized representative of the federal, state, or local government.
- 2.24 **Right to Assurance:** Whenever the County in good faith has reason to question the other party's intent to perform. The County may demand that the other party give written assurance of his intent to perform. In the event that a demand is made and no assurance is given within five (5) days, the County may treat this failure as an anticipatory repudiation of the contract.
- 2.25 **Venue:** Both parties agree that venue for any litigation arising from this contract shall lie in Richmond, Fort Bend County, Texas.
- 2.26 **Prohibition Against Personal Interest in Contracts:** No officer or employee of the County shall have a financial interest, direct or indirect, in any contract with the County, or shall be financially interested, directly or indirectly, in the sale to the County of any land, materials, supplies, or service, except on behalf of the County as an officer or employee. Any willful violation of this section shall constitute malfeasance in office, and any officer or employee guilty thereof shall be subject to disciplinary action under applicable laws, statutes and codes of the State of Texas. Any violation of this section, with the knowledge, expressed or implied of the person or corporation contracting with the County shall render the contract involved voidable by the County Commissioners Court.

3.0 SCOPE:

It is the intent of Fort Bend County to contract with one (1) or more vendors to provide traffic signs, posts and supplies for Fort Bend County as specified herein.

4.0 TERM OF CONTRACT:

The term of this contract is **April 1, 2021 through March 31, 2022**, renewable annually for four (4) years (through 31 March 2026) under the same terms and conditions if mutually agreeable by both parties. Either party for any reason may terminate this contract by giving thirty (30) days written notice of the intent to terminate.

Initials of Bidder: JT

5.0 TEXAS ETHICS COMMISSION FORM 1295:

- 5.1 Effective January 1, 2016 all contracts executed by Commissioners Court, regardless of the dollar amount, will require completion of Form 1295 "Certificate of Interested Parties", per the new Government Code Statute §2252.908. All vendors submitting a response to a formal Bid, RFP, SOQ or any contracts, contract amendments, renewals or change orders are required to complete the Form 1295 online through the State of Texas Ethics Commission website. Please visit: https://www.ethics.state.tx.us/whatsnew/elf_info_form1295.htm.
- 5.2 On-line instructions:
 - 5.2.1 Name of governmental entity is to read: Fort Bend County.
 - 5.2.2 Identification number used by the governmental entity is: B21-048.
 - 5.2.3 Description is the title of the solicitation: Traffic Signs, Posts, Supplies.
- 5.3 Apparent low bidder(s) will be required to provide the Form 1295 within three (3) calendar days from notification; however, if your company is publicly traded you are not required to complete this form.

6.0 STATE LAW REQUIREMENTS FOR CONTRACTS:

The contents of this section are required by Texas Law and are included by County regardless of content.

- 6.1 Agreement to Not Boycott Israel Chapter 2270 Texas Government Code: By signature on vendor form, Contractor verifies Contractor does not boycott Israel and will not boycott Israel during the term of this Contract.
- 6.2 Texas Government Code Section 2251.152 Acknowledgment: By signature on vendor form, Contractor represents pursuant to Section 2252.152 of the Texas Government Code, that Contractor is not listed on the website of the Comptroller of the State of Texas concerning the listing of companies that are identified under Section 806.051, Section 807.051 or Section 2253.153.

7.0 HUMAN TRAFFICKING:

By acceptance of this contract, Contractor acknowledges that Fort Bend County is opposed to human trafficking and that no County funds will be used in support of services or activities that violate human trafficking laws.

Initials of Bidder: JT

8.0 ASSIGNMENT:

Contractor shall not sell, assign, transfer or convey these services, in whole or in part, without the prior written consent of Fort Bend County and as a condition of such consent, contractor shall remain liable for completion of the services in the event of default by the successor contractor or assignee.

9.0 AWARD:

This contract will be awarded to the lowest and best bidder per section.

10.0 GENERAL:

- 10.1 Quantities listed are estimates only. Fort Bend County does not guarantee the quantities stated will be purchased.
- 10.2 No minimum orders, by quantity or dollar amount.
- 10.3 Bidders may be required to submit samples for inspection and evaluation after bid opening to determine acceptability.

11.0 DELIVERY:

- 11.1 Vendor must complete delivery within thirty (30) working days after receipt of purchase order.
- 11.2 The successful bidder shall not deliver products without a Purchase Order issued by the Fort Bend County Purchasing Agent.
- 11.3 The successful bidder shall not deliver products or services in excess of those authorized and under no circumstances will Fort Bend County be liable for payment of products or services, which exceed the amounts authorized by the purchase order.
- 11.4 All orders must be delivered between 8:00 AM and 3:00 PM, Monday through Friday to the address indicated on purchase order.

12.0 SPECIFICATIONS and BID PRICING:

Specifications are located in the Excel pricing form downloadable from Fort Bend County's website. Provide bid prices in the electronic Excel file and return as stated in Section 1.4 and 1.5.

13.0 QUALITY CONTROL:

Fort Bend County reserves the right to sample and test products at time of delivery for specification compliance in the presence of the driver or vendor's representative. Costs for tests shall be borne by the Contractor in the event product fails to meet specifications. Products not in their original

Initials of Bidder: JT

package will not be accepted.

14.0 REQUIRED FORMS:

All vendors submitting are required to complete and provide with submission:

- 14.1 Electronic Excel file of Pricing Form on CD or flash drive and printed hard copy
- 14.2 Vendor Form
- 14.3 W9 Form
- 14.4 Tax Form/Debt/Residence Certification

Initials of Bidder: JT

**Contract Sheet
Bid 21-048**

**THE STATE OF TEXAS
COUNTY OF FORT BEND**

This memorandum of agreement made and entered into on the 23rd day of March, 2021,
by and between Fort Bend County in the State of Texas (hereinafter designated County), acting herein by
County Judge KP George, by virtue of an order of Fort Bend County Commissioners Court, and
Osburn Associates, Inc. (hereinafter designated Contractor).
(company name)

WITNESSETH:

The Contractor and the County agree that the bid and specifications for the **Purchase of Oil and
Lubricants** which are hereto attached and made a part hereof, together with this instrument and the bond
(when required) shall constitute the full agreement and contract between parties and for furnishing the items set
out and described; the County agrees to pay the prices stipulated in the accepted bid.

It is further agreed that this contract shall not become binding or effective until signed by the parties hereto
and a purchase order authorizing the items desired has been issued.

Executed at Richmond, Texas this 23 day of March, 2021.



Fort Bend County, Texas

By: _____
County Judge, KP George

By:  _____
Signature of Contractor

By: Jennifer Treadway / Bidding Agent
Printed Name and Title

COUNTY PURCHASING AGENT

Fort Bend County, Texas



Jaime Kovar
County Purchasing Agent

(281) 341-8640
Fax (281) 341-8645

January 4, 2021

TO: All Prospective Bidders

RE: Addendum No. 1 – Fort Bend County Bid 21-048 – Traffic Signs, Posts & Supplies

Addendum 1:

Attached is addendum 1. Vendors are to use Addendum 1 document while preparing their solicitation response. Contract name updated on Contract Sheet, page 17.

Immediately upon your receipt of this addendum, please fill out the following information and email this page to Jessica Carabajal at jessica.carabajal@fortbendcountytexas.gov

Osburn Associates, Inc.

Company Name

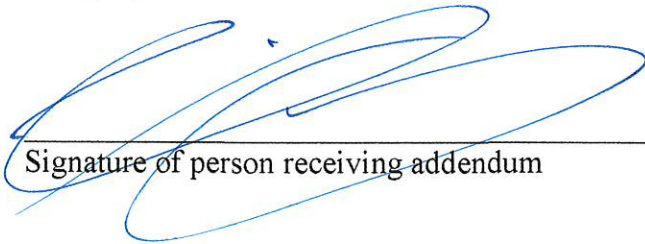

Signature of person receiving addendum

1/15/2021

Date

If you have any questions, please contact this office.

Sincerely,



Cheryl Krejci
Senior Buyer

Request for Taxpayer Identification Number and Certification

**Give Form to the
 requester. Do not
 send to the IRS.**

Print or type See Specific Instructions on page 2.	1 Name (as shown on your income tax return). Name is required on this line; do not leave this line blank. <i>Osburn Associates, Inc.</i>		
	2 Business name/disregarded entity name, if different from above		
	3 Check appropriate box for federal tax classification; check <u>only one</u> of the following seven boxes: <input type="checkbox"/> Individual/sole proprietor or single-member LLC <input type="checkbox"/> C Corporation <input checked="" type="checkbox"/> S Corporation <input type="checkbox"/> Partnership <input type="checkbox"/> Trust/estate <input type="checkbox"/> limited liability company. Enter the tax classification (C=C corporation, S=S corporation, P=partnership) ▶ _____ Note. For a single-member LLC that is disregarded, do not check LLC; check the appropriate box in the line above for the tax classification of the single-member owner. <input type="checkbox"/> Other (see instructions) ▶ _____		
	4 Exemptions (codes apply only to certain entities, not individuals; see instructions on page 3): Exempt payee code (if any) _____ Exemption from FATCA reporting code (if any) _____ <small>(Applies to accounts maintained outside the U.S.)</small>		
	5 Address (number, street, and apt. or suite no.) <i>P.O. Box 912</i>		Requester's name and address (optional)
	6 City, state, and ZIP code <i>Logan, OH 43138</i>		
	7 List account number(s) here (optional)		

Part I Taxpayer Identification Number (TIN)

Enter your TIN in the appropriate box. The TIN provided must match the name given on line 1 to avoid backup withholding. For individuals, this is generally your social security number (SSN). However, for a resident alien, sole proprietor, or disregarded entity, see the Part I instructions on page 3. For other entities, it is your employer identification number (EIN). If you do not have a number, see *How to get a TIN* on page 3.

Social security number									

Note. If the account is in more than one name, see the instructions for line 1 and the chart on page 4 for guidelines on whose number to enter.

or

Employer identification number									
3									

Part II Certification

- Under penalties of perjury, I certify that:
- The number shown on this form is my correct taxpayer identification number (or I am waiting for a number to be issued to me); and
 - I am not subject to backup withholding because: (a) I am exempt from backup withholding, or (b) I have not been notified by the Internal Revenue Service (IRS) that I am subject to backup withholding as a result of a failure to report all interest or dividends, or (c) the IRS has notified me that I am no longer subject to backup withholding; and
 - I am a U.S. citizen or other U.S. person (defined below); and
 - The FATCA code(s) entered on this form (if any) indicating that I am exempt from FATCA reporting is correct.

Certification instructions. You must cross out item 2 above if you have been notified by the IRS that you are currently subject to backup withholding because you have failed to report all interest and dividends on your tax return. For real estate transactions, item 2 does not apply. For mortgage interest paid, acquisition or abandonment of secured property, cancellation of debt, contributions to an individual retirement arrangement (IRA), and generally, payments other than interest and dividends, you are not required to sign the certification, but you must provide your correct TIN. See the instructions on page 3.

Sign Here	Signature of U.S. person ▶	Date ▶ <i>1/14/2021</i>
------------------	----------------------------	-------------------------

General Instructions

Section references are to the Internal Revenue Code unless otherwise noted.
Future developments. Information about developments affecting Form W-9 (such as legislation enacted after we release it) is at www.irs.gov/fw9.

Purpose of Form

- An individual or entity (Form W-9 requester) who is required to file an information return with the IRS must obtain your correct taxpayer identification number (TIN) which may be your social security number (SSN), individual taxpayer identification number (ITIN), adoption taxpayer identification number (ATIN), or employer identification number (EIN), to report on an information return the amount paid to you, or other amount reportable on an information return. Examples of information returns include, but are not limited to, the following:
- Form 1099-INT (interest earned or paid)
 - Form 1099-DIV (dividends, including those from stocks or mutual funds)
 - Form 1099-MISC (various types of income, prizes, awards, or gross proceeds)
 - Form 1099-B (stock or mutual fund sales and certain other transactions by brokers)
 - Form 1099-S (proceeds from real estate transactions)
 - Form 1099-K (merchant card and third party network transactions)

- Form 1098 (home mortgage interest), 1098-E (student loan interest), 1098-T (tuition)
 - Form 1099-C (canceled debt)
 - Form 1099-A (acquisition or abandonment of secured property)
- Use Form W-9 only if you are a U.S. person (including a resident alien), to provide your correct TIN.
- If you do not return Form W-9 to the requester with a TIN, you might be subject to backup withholding. See What is backup withholding? on page 2.*
- By signing the filled-out form, you:
- Certify that the TIN you are giving is correct (or you are waiting for a number to be issued),
 - Certify that you are not subject to backup withholding, or
 - Claim exemption from backup withholding if you are a U.S. exempt payee. If applicable, you are also certifying that as a U.S. person, your allocable share of any partnership income from a U.S. trade or business is not subject to the withholding tax on foreign partners' share of effectively connected income, and
 - Certify that FATCA code(s) entered on this form (if any) indicating that you are exempt from the FATCA reporting, is correct. See *What is FATCA reporting?* on page 2 for further information.

Note. If you are a U.S. person and a requester gives you a form other than Form W-9 to request your TIN, you must use the requester's form if it is substantially similar to this Form W-9.

Definition of a U.S. person. For federal tax purposes, you are considered a U.S. person if you are:

- An individual who is a U.S. citizen or U.S. resident alien;
- A partnership, corporation, company, or association created or organized in the United States or under the laws of the United States;
- An estate (other than a foreign estate); or
- A domestic trust (as defined in Regulations section 301.7701-7).

Special rules for partnerships. Partnerships that conduct a trade or business in the United States are generally required to pay a withholding tax under section 1446 on any foreign partners' share of effectively connected taxable income from such business. Further, in certain cases where a Form W-9 has not been received, the rules under section 1446 require a partnership to presume that a partner is a foreign person, and pay the section 1446 withholding tax. Therefore, if you are a U.S. person that is a partner in a partnership conducting a trade or business in the United States, provide Form W-9 to the partnership to establish your U.S. status and avoid section 1446 withholding on your share of partnership income.

In the cases below, the following person must give Form W-9 to the partnership for purposes of establishing its U.S. status and avoiding withholding on its allocable share of net income from the partnership conducting a trade or business in the United States:

- In the case of a disregarded entity with a U.S. owner, the U.S. owner of the disregarded entity and not the entity;
- In the case of a grantor trust with a U.S. grantor or other U.S. owner, generally, the U.S. grantor or other U.S. owner of the grantor trust and not the trust; and
- In the case of a U.S. trust (other than a grantor trust), the U.S. trust (other than a grantor trust) and not the beneficiaries of the trust.

Foreign person. If you are a foreign person or the U.S. branch of a foreign bank that has elected to be treated as a U.S. person, do not use Form W-9. Instead, use the appropriate Form W-8 or Form 8233 (see Publication 515, Withholding of Tax on Nonresident Aliens and Foreign Entities).

Nonresident alien who becomes a resident alien. Generally, only a nonresident alien individual may use the terms of a tax treaty to reduce or eliminate U.S. tax on certain types of income. However, most tax treaties contain a provision known as a "saving clause." Exceptions specified in the saving clause may permit an exemption from tax to continue for certain types of income even after the payee has otherwise become a U.S. resident alien for tax purposes.

If you are a U.S. resident alien who is relying on an exception contained in the saving clause of a tax treaty to claim an exemption from U.S. tax on certain types of income, you must attach a statement to Form W-9 that specifies the following five items:

1. The treaty country. Generally, this must be the same treaty under which you claimed exemption from tax as a nonresident alien.
2. The treaty article addressing the income.
3. The article number (or location) in the tax treaty that contains the saving clause and its exceptions.
4. The type and amount of income that qualifies for the exemption from tax.
5. Sufficient facts to justify the exemption from tax under the terms of the treaty article.

Example. Article 20 of the U.S.-China income tax treaty allows an exemption from tax for scholarship income received by a Chinese student temporarily present in the United States. Under U.S. law, this student will become a resident alien for tax purposes if his or her stay in the United States exceeds 5 calendar years. However, paragraph 2 of the first Protocol to the U.S.-China treaty (dated April 30, 1984) allows the provisions of Article 20 to continue to apply even after the Chinese student becomes a resident alien of the United States. A Chinese student who qualifies for this exception (under paragraph 2 of the first protocol) and is relying on this exception to claim an exemption from tax on his or her scholarship or fellowship income would attach to Form W-9 a statement that includes the information described above to support that exemption.

If you are a nonresident alien or a foreign entity, give the requester the appropriate completed Form W-8 or Form 8233.

Backup Withholding

What is backup withholding? Persons making certain payments to you must under certain conditions withhold and pay to the IRS 28% of such payments. This is called "backup withholding." Payments that may be subject to backup withholding include interest, tax-exempt interest, dividends, broker and barter exchange transactions, rents, royalties, nonemployee pay, payments made in settlement of payment card and third party network transactions, and certain payments from fishing boat operators. Real estate transactions are not subject to backup withholding.

You will not be subject to backup withholding on payments you receive if you give the requester your correct TIN, make the proper certifications, and report all your taxable interest and dividends on your tax return.

Payments you receive will be subject to backup withholding if:

1. You do not furnish your TIN to the requester,
2. You do not certify your TIN when required (see the Part II instructions on page 3 for details),

3. The IRS tells the requester that you furnished an incorrect TIN,

4. The IRS tells you that you are subject to backup withholding because you did not report all your interest and dividends on your tax return (for reportable interest and dividends only), or

5. You do not certify to the requester that you are not subject to backup withholding under 4 above (for reportable interest and dividend accounts opened after 1983 only).

Certain payees and payments are exempt from backup withholding. See *Exempt payee code* on page 3 and the separate instructions for the Requester of Form W-9 for more information.

Also see *Special rules for partnerships* above.

What is FATCA reporting?

The Foreign Account Tax Compliance Act (FATCA) requires a participating foreign financial institution to report all United States account holders that are specified United States persons. Certain payees are exempt from FATCA reporting. See *Exemption from FATCA reporting code* on page 3 and the instructions for the Requester of Form W-9 for more information.

Updating Your Information

You must provide updated information to any person to whom you claimed to be an exempt payee if you are no longer an exempt payee and anticipate receiving reportable payments in the future from this person. For example, you may need to provide updated information if you are a C corporation that elects to be an S corporation, or if you no longer are tax exempt. In addition, you must furnish a new Form W-9 if the name or TIN changes for the account; for example, if the grantor of a grantor trust dies.

Penalties

Failure to furnish TIN. If you fail to furnish your correct TIN to a requester, you are subject to a penalty of \$50 for each such failure unless your failure is due to reasonable cause and not to willful neglect.

Civil penalty for false information with respect to withholding. If you make a false statement with no reasonable basis that results in no backup withholding, you are subject to a \$500 penalty.

Criminal penalty for falsifying information. Willfully falsifying certifications or affirmations may subject you to criminal penalties including fines and/or imprisonment.

Misuse of TINs. If the requester discloses or uses TINs in violation of federal law, the requester may be subject to civil and criminal penalties.

Specific Instructions

Line 1

You must enter one of the following on this line; do not leave this line blank. The name should match the name on your tax return.

If this Form W-9 is for a joint account, list first, and then circle, the name of the person or entity whose number you entered in Part I of Form W-9.

a. Individual. Generally, enter the name shown on your tax return. If you have changed your last name without informing the Social Security Administration (SSA) of the name change, enter your first name, the last name as shown on your social security card, and your new last name.

Note. ITIN applicant: Enter your individual name as it was entered on your Form W-7 application, line 1a. This should also be the same as the name you entered on the Form 1040/1040A/1040EZ you filed with your application.

b. Sole proprietor or single-member LLC. Enter your individual name as shown on your 1040/1040A/1040EZ on line 1. You may enter your business, trade, or "doing business as" (DBA) name on line 2.

c. Partnership, LLC that is not a single-member LLC, C Corporation, or S Corporation. Enter the entity's name as shown on the entity's tax return on line 1 and any business, trade, or DBA name on line 2.

d. Other entities. Enter your name as shown on required U.S. federal tax documents on line 1. This name should match the name shown on the charter or other legal document creating the entity. You may enter any business, trade, or DBA name on line 2.

e. Disregarded entity. For U.S. federal tax purposes, an entity that is disregarded as an entity separate from its owner is treated as a "disregarded entity." See Regulations section 301.7701-2(c)(2)(iii). Enter the owner's name on line 1. The name of the entity entered on line 1 should never be a disregarded entity. The name on line 1 should be the name shown on the income tax return on which the income should be reported. For example, if a foreign LLC that is treated as a disregarded entity for U.S. federal tax purposes has a single owner that is a U.S. person, the U.S. owner's name is required to be provided on line 1. If the direct owner of the entity is also a disregarded entity, enter the first owner that is not disregarded for federal tax purposes. Enter the disregarded entity's name on line 2, "Business name/disregarded entity name." If the owner of the disregarded entity is a foreign person, the owner must complete an appropriate Form W-8 instead of a Form W-9. This is the case even if the foreign person has a U.S. TIN.

Line 2

If you have a business name, trade name, DBA name, or disregarded entity name, you may enter it on line 2.

Line 3

Check the appropriate box in line 3 for the U.S. federal tax classification of the person whose name is entered on line 1. Check only one box in line 3.

Limited Liability Company (LLC). If the name on line 1 is an LLC treated as a partnership for U.S. federal tax purposes, check the "Limited Liability Company" box and enter "P" in the space provided, if the LLC has filed Form 8832 or 2553 to be taxed as a corporation, check the "Limited Liability Company" box and in the space provided enter "C" for C corporation or "S" for S corporation. If it is a single-member LLC that is a disregarded entity, do not check the "Limited Liability Company" box; instead check the first box in line 3 "Individual/sole proprietor or single-member LLC."

Line 4, Exemptions

If you are exempt from backup withholding and/or FATCA reporting, enter in the appropriate space in line 4 any code(s) that may apply to you.

Exempt payee code.

- Generally, individuals (including sole proprietors) are not exempt from backup withholding.
- Except as provided below, corporations are exempt from backup withholding for certain payments, including interest and dividends.
- Corporations are not exempt from backup withholding for payments made in settlement of payment card or third party network transactions.
- Corporations are not exempt from backup withholding with respect to attorneys' fees or gross proceeds paid to attorneys, and corporations that provide medical or health care services are not exempt with respect to payments reportable on Form 1099-MISC.

The following codes identify payees that are exempt from backup withholding. Enter the appropriate code in the space in line 4.

- 1—An organization exempt from tax under section 501(a), any IRA, or a custodial account under section 403(b)(7) if the account satisfies the requirements of section 401(f)(2)
- 2—The United States or any of its agencies or instrumentalities
- 3—A state, the District of Columbia, a U.S. commonwealth or possession, or any of their political subdivisions or instrumentalities
- 4—A foreign government or any of its political subdivisions, agencies, or instrumentalities
- 5—A corporation
- 6—A dealer in securities or commodities required to register in the United States, the District of Columbia, or a U.S. commonwealth or possession
- 7—A futures commission merchant registered with the Commodity Futures Trading Commission
- 8—A real estate investment trust
- 9—An entity registered at all times during the tax year under the Investment Company Act of 1940
- 10—A common trust fund operated by a bank under section 584(a)
- 11—A financial institution
- 12—A middleman known in the investment community as a nominee or custodian
- 13—A trust exempt from tax under section 664 or described in section 4947

The following chart shows types of payments that may be exempt from backup withholding. The chart applies to the exempt payees listed above, 1 through 13.

IF the payment is for . . .	THEN the payment is exempt for . . .
Interest and dividend payments	All exempt payees except for 7
Broker transactions	Exempt payees 1 through 4 and 6 through 11 and all C corporations. S corporations must not enter an exempt payee code because they are exempt only for sales of noncovered securities acquired prior to 2012.
Barter exchange transactions and patronage dividends	Exempt payees 1 through 4
Payments over \$600 required to be reported and direct sales over \$5,000 ¹	Generally, exempt payees 1 through 5 ²
Payments made in settlement of payment card or third party network transactions	Exempt payees 1 through 4

¹ See Form 1099-MISC, Miscellaneous Income, and its instructions.

² However, the following payments made to a corporation and reportable on Form 1099-MISC are not exempt from backup withholding: medical and health care payments, attorneys' fees, gross proceeds paid to an attorney reportable under section 6045(f), and payments for services paid by a federal executive agency.

Exemption from FATCA reporting code. The following codes identify payees that are exempt from reporting under FATCA. These codes apply to persons submitting this form for accounts maintained outside of the United States by certain foreign financial institutions. Therefore, if you are only submitting this form for an account you hold in the United States, you may leave this field blank. Consult with the person requesting this form if you are uncertain if the financial institution is subject to these requirements. A requester may indicate that a code is not required by providing you with a Form W-9 with "Not Applicable" (or any similar indication) written or printed on the line for a FATCA exemption code.

A—An organization exempt from tax under section 501(a) or any individual retirement plan as defined in section 7701(a)(37)

B—The United States or any of its agencies or instrumentalities

C—A state, the District of Columbia, a U.S. commonwealth or possession, or any of their political subdivisions or instrumentalities

D—A corporation the stock of which is regularly traded on one or more established securities markets, as described in Regulations section 1.1472-1(c)(1)(i)

E—A corporation that is a member of the same expanded affiliated group as a corporation described in Regulations section 1.1472-1(c)(1)(i)

F—A dealer in securities, commodities, or derivative financial instruments (including notional principal contracts, futures, forwards, and options) that is registered as such under the laws of the United States or any state

G—A real estate investment trust

H—A regulated investment company as defined in section 851 or an entity registered at all times during the tax year under the Investment Company Act of 1940

I—A common trust fund as defined in section 584(a)

J—A bank as defined in section 581

K—A broker

L—A trust exempt from tax under section 664 or described in section 4947(a)(1)

M—A tax exempt trust under a section 403(b) plan or section 457(g) plan

Note. You may wish to consult with the financial institution requesting this form to determine whether the FATCA code and/or exempt payee code should be completed.

Line 5

Enter your address (number, street, and apartment or suite number). This is where the requester of this Form W-9 will mail your information returns.

Line 6

Enter your city, state, and ZIP code.

Part I. Taxpayer Identification Number (TIN)

Enter your TIN in the appropriate box. If you are a resident alien and you do not have and are not eligible to get an SSN, your TIN is your IRS individual taxpayer identification number (ITIN). Enter it in the social security number box. If you do not have an ITIN, see *How to get a TIN* below.

If you are a sole proprietor and you have an EIN, you may enter either your SSN or EIN. However, the IRS prefers that you use your SSN.

If you are a single-member LLC that is disregarded as an entity separate from its owner (see *Limited Liability Company (LLC)* on this page), enter the owner's SSN (or EIN, if the owner has one). Do not enter the disregarded entity's EIN. If the LLC is classified as a corporation or partnership, enter the entity's EIN.

Note. See the chart on page 4 for further clarification of name and TIN combinations.

How to get a TIN. If you do not have a TIN, apply for one immediately. To apply for an SSN, get Form SS-5, Application for a Social Security Card, from your local SSA office or get this form online at www.ssa.gov. You may also get this form by calling 1-800-772-1213. Use Form W-7, Application for IRS Individual Taxpayer Identification Number, to apply for an ITIN, or Form SS-4, Application for Employer Identification Number, to apply for an EIN. You can apply for an EIN online by accessing the IRS website at www.irs.gov/businesses and clicking on Employer Identification Number (EIN) under Starting a Business. You can get Forms W-7 and SS-4 from the IRS by visiting irs.gov or by calling 1-800-TAX-FORM (1-800-829-3676).

If you are asked to complete Form W-9 but do not have a TIN, apply for a TIN and write "Applied For" in the space for the TIN, sign and date the form, and give it to the requester. For interest and dividend payments, and certain payments made with respect to readily tradable instruments, generally you will have 60 days to get a TIN and give it to the requester before you are subject to backup withholding on payments. The 60-day rule does not apply to other types of payments. You will be subject to backup withholding on all such payments until you provide your TIN to the requester.

Note. Entering "Applied For" means that you have already applied for a TIN or that you intend to apply for one soon.

Caution: A disregarded U.S. entity that has a foreign owner must use the appropriate Form W-8.

Part II. Certification

To establish to the withholding agent that you are a U.S. person, or resident alien, sign Form W-9. You may be requested to sign by the withholding agent even if items 1, 4, or 5 below indicate otherwise.

For a joint account, only the person whose TIN is shown in Part I should sign (when required). In the case of a disregarded entity, the person identified on line 1 must sign. Exempt payees, see *Exempt payee code* earlier.

Signature requirements. Complete the certification as indicated in items 1 through 5 below.

1. **Interest, dividend, and barter exchange accounts opened before 1994 and broker accounts considered active during 1993.** You must give your correct TIN, but you do not have to sign the certification.
2. **Interest, dividend, broker, and barter exchange accounts opened after 1993 and broker accounts considered inactive during 1993.** You must sign the certification or backup withholding will apply. If you are subject to backup withholding and you are merely providing your correct TIN to the requester, you must cross out item 2 in the certification before signing the form.
3. **Real estate transactions.** You must sign the certification. You may cross out item 2 of the certification.
4. **Other payments.** You must give your correct TIN, but you do not have to sign the certification unless you have been notified that you have previously given an incorrect TIN. "Other payments" include payments made in the course of the requester's trade or business for rents, royalties, goods (other than bills for merchandise), medical and health care services (including payments to corporations), payments to a nonemployee for services, payments made in settlement of payment card and third party network transactions, payments to certain fishing boat crew members and fishermen, and gross proceeds paid to attorneys (including payments to corporations).
5. **Mortgage interest paid by you, acquisition or abandonment of secured property, cancellation of debt, qualified tuition program payments (under section 529), IRA, Coverdell ESA, Archer MSA or HSA contributions or distributions, and pension distributions.** You must give your correct TIN, but you do not have to sign the certification.

What Name and Number To Give the Requester

For this type of account:	Give name and SSN of:
1. Individual	The individual
2. Two or more individuals (joint account)	The actual owner of the account or, if combined funds, the first individual on the account ¹
3. Custodian account of a minor (Uniform Gift to Minors Act)	The minor ²
4. a. The usual revocable savings trust (grantor is also trustee) b. So-called trust account that is not a legal or valid trust under state law	The grantor-trustee ¹ The actual owner ¹
5. Sole proprietorship or disregarded entity owned by an individual	The owner ³
6. Grantor trust filing under Optional Form 1099 Filing Method 1 (see Regulations section 1.671-4(b)(2)(i)(A))	The grantor ⁴
For this type of account:	Give name and EIN of:
7. Disregarded entity not owned by an individual	The owner
8. A valid trust, estate, or pension trust	Legal entity ⁴
9. Corporation or LLC electing corporate status on Form 8832 or Form 2553	The corporation
10. Association, club, religious, charitable, educational, or other tax-exempt organization	The organization
11. Partnership or multi-member LLC	The partnership
12. A broker or registered nominee	The broker or nominee
13. Account with the Department of Agriculture in the name of a public entity (such as a state or local government, school district, or prison) that receives agricultural program payments	The public entity
14. Grantor trust filing under the Form 1041 Filing Method or the Optional Form 1099 Filing Method 2 (see Regulations section 1.671-4(b)(2)(i)(B))	The trust

¹ List first and circle the name of the person whose number you furnish. If only one person on a joint account has an SSN, that person's number must be furnished.
² Circle the minor's name and furnish the minor's SSN.

³ You must show your individual name and you may also enter your business or DBA name on the "Business name/disregarded entity" name line. You may use either your SSN or EIN (if you have one), but the IRS encourages you to use your SSN.
⁴ List first and circle the name of the trust, estate, or pension trust. (Do not furnish the TIN of the personal representative or trustee unless the legal entity itself is not designated in the account title.) Also see *Special rules for partnerships* on page 2.
 *Note. Grantor also must provide a Form W-9 to trustee of trust.

Note. If no name is circled when more than one name is listed, the number will be considered to be that of the first name listed.

Secure Your Tax Records from Identity Theft

Identity theft occurs when someone uses your personal information such as your name, SSN, or other identifying information, without your permission, to commit fraud or other crimes. An identity thief may use your SSN to get a job or may file a tax return using your SSN to receive a refund.

To reduce your risk:

- Protect your SSN,
- Ensure your employer is protecting your SSN, and
- Be careful when choosing a tax preparer.

If your tax records are affected by identity theft and you receive a notice from the IRS, respond right away to the name and phone number printed on the IRS notice or letter.

If your tax records are not currently affected by identity theft but you think you are at risk due to a lost or stolen purse or wallet, questionable credit card activity or credit report, contact the IRS Identity Theft Hotline at 1-800-908-4490 or submit Form 14039.

For more information, see Publication 4535, Identity Theft Prevention and Victim Assistance.

Victims of identity theft who are experiencing economic harm or a system problem, or are seeking help in resolving tax problems that have not been resolved through normal channels, may be eligible for Taxpayer Advocate Service (TAS) assistance. You can reach TAS by calling the TAS toll-free case intake line at 1-877-777-4778 or TTY/TDD 1-800-829-4059.

Protect yourself from suspicious emails or phishing schemes. Phishing is the creation and use of email and websites designed to mimic legitimate business emails and websites. The most common act is sending an email to a user falsely claiming to be an established legitimate enterprise in an attempt to scam the user into surrendering private information that will be used for identity theft.

The IRS does not initiate contacts with taxpayers via emails. Also, the IRS does not request personal detailed information through email or ask taxpayers for the PIN numbers, passwords, or similar secret access information for their credit card, bank, or other financial accounts.

If you receive an unsolicited email claiming to be from the IRS, forward this message to phishing@irs.gov. You may also report misuse of the IRS name, logo, or other IRS property to the Treasury Inspector General for Tax Administration (TIGTA) at 1-800-366-4484. You can forward suspicious emails to the Federal Trade Commission at: spam@uce.gov or contact them at www.ftc.gov/idtheft or 1-877-IDTHEFT (1-877-438-4338).

Visit IRS.gov to learn more about identity theft and how to reduce your risk.

Privacy Act Notice

Section 6109 of the Internal Revenue Code requires you to provide your correct TIN to persons (including federal agencies) who are required to file information returns with the IRS to report interest, dividends, or certain other income paid to you; mortgage interest you paid; the acquisition or abandonment of secured property; the cancellation of debt; or contributions you made to an IRA, Archer MSA, or HSA. The person collecting this form uses the information on the form to file information returns with the IRS, reporting the above information. Routine uses of this information include giving it to the Department of Justice for civil and criminal litigation and to cities, states, the District of Columbia, and U.S. commonwealths and possessions for use in administering their laws. The information also may be disclosed to other countries under a treaty, to federal and state agencies to enforce civil and criminal laws, or to federal law enforcement and intelligence agencies to combat terrorism. You must provide your TIN whether or not you are required to file a tax return. Under section 3406, payers must generally withhold a percentage of taxable interest, dividend, and certain other payments to a payee who does not give a TIN to the payer. Certain penalties may also apply for providing false or fraudulent information.

Fort Bend County Pricing Form
 BID 21-048
 Term Contract for Traffic Signs, Posts and Supplies

Vendor Name: Osburn Associates, Inc.

Section 1: Complete Signs Finished traffic signs must be .080 aluminum with faces, diamond grade, VIP, reflective sheeting. Add 3M protective overlay film (series 1160) to each sign.	Estimated Annual Quantity	Bid Price per Each	Extended Cost
All way, 18 x 6, red white VIP diamond Grade (MUTCD R1-4)	400	NO BID	#VALUE!
Watch for ice on bridge, 36 x 36, hinged with closure hook, fluorescent yellow, diamond grade material	100	NO BID	#VALUE!
Type III, 12x36, fluorescent yellow, DG3, (MUTCD OM-3R)	50	NO BID	#VALUE!
Type III, 12x36, fluorescent yellow, DG3, (MUTCD OM-3L)	50	NO BID	#VALUE!
Total Section 1:			#VALUE!

Vendor Name: Osburn Associates, Inc.

Section 2: Blanks Blanks must be .080 aluminum	Estimated Annual Quantity	Bid Price per Each	Extended Cost
Blanks, rounded corners, diamond punch 18 x 18	1000	\$5.36	\$ 5,360.00
Blanks, rounded corners, diamond punch 24 x 24	1000	\$9.52	\$ 9,520.00
Blanks, rounded corners, diamond punch 30 x 30	1000	\$14.88	\$ 14,880.00
Blanks, rounded corners, diamond punch 36 x 36	500	\$21.42	\$ 10,710.00
Blanks, octagon 30 x 30	1000	\$14.88	\$ 14,880.00
Blanks, octagon 36 x 36	300	\$21.42	\$ 6,426.00
Blanks, pentagon 30 x 30	300	\$14.88	\$ 4,464.00
Blanks, pentagon 36 x 36	65	\$21.42	\$ 1,392.30
Blanks, rounded corners, rectangle 24 x 8	400	\$3.17	\$ 1,268.00
Blanks, rounded corners, rectangle 24 x 10	400	\$3.97	\$ 1,588.00
Blanks, rounded corners, rectangle 24 x 12	400	\$4.76	\$ 1,904.00
Blanks, rounded corners, rectangle 12 x 18	400	\$3.57	\$ 1,428.00
Blanks, rounded corners, rectangle 18 x 24	400	\$7.14	\$ 2,856.00
Blanks, rounded corners, rectangle 24 x 30	1000	\$11.90	\$ 11,900.00
Blanks, rounded corners, rectangle 24 x 36	300	\$14.28	\$ 4,284.00
Blanks, rounded corners, rectangle 30 x 36	100	\$17.85	\$ 1,785.00
Blanks, rounded corners, rectangle 24 x 48	500	\$19.05	\$ 9,525.00
Blanks, rounded corners, rectangle 30 x 48	100	\$23.80	\$ 2,380.00
Blanks, rounded corners, rectangle 36 x 18	500	\$10.71	\$ 5,355.00
Blanks, rounded corners, square 18 x 18	1000	\$5.36	\$ 5,360.00
Blanks, rounded corners, square 24 x 24	1000	\$9.52	\$ 9,520.00
Blanks, rounded corners, street sign, flat, 9 x 30	600	\$4.46	\$ 2,676.00
Blanks, rounded corners, street sign, flat, 9 x 36	600	\$5.36	\$ 3,216.00
Blanks, rounded corners, street sign, flat, 9 x 42	600	\$6.24	\$ 3,744.00
Blanks, rounded corners, street sign, flat, 9 x 48	600	\$7.14	\$ 4,284.00
Blanks, round, 36" diameter	300	\$21.42	\$ 6,426.00
Blanks, rounded corners, rectangle, 10 x 30	300	\$4.96	\$ 1,488.00
Blanks, rounded corners, rectangle, 12 x 30	300	\$5.95	\$ 1,785.00
Blanks, rounded corners, triangle, 30	500	\$8.93	\$ 4,465.00
Blanks, rounded corners, triangle, 36	500	\$16.66	\$ 8,330.00
Blanks, extruded, 9 x 30	1000	\$8.78	\$ 8,780.00
Blanks, extruded, 9 x 36	1000	\$10.53	\$ 10,530.00
Blanks, extruded, 9 x 42	1000	\$12.26	\$ 12,260.00
Blanks, extruded, 9 x 48	1000	\$14.04	\$ 14,040.00
Blanks, extruded, 9 x 54	1000	\$15.77	\$ 15,770.00
Total Section 2:			\$ 224,579.30

Vendor Name: Osburn Associates, Inc.

Section 3: Posts and Accessories-Telespar Sign Support System	Estimated Annual Quantity	Bid Price per Each	Extended Cost
12' Round 2.375 16 gauge galvanized post	500	NO BID	#VALUE!
14' 1-3/4"x1-3/4" square 12 gauge galvanized sign post	500	NO BID	#VALUE!
12" round post cap flat blade for 2.375" round post	500	NO BID	#VALUE!
12" round post cap extruded for 2.375" round post	500	NO BID	#VALUE!
**74-5606 TRF RD RW 2.375 16 gauge Post, 12'	500	NO BID	#VALUE!
75-4892 TRF RD Taper 2.875 Poz Loc Sockets	500	NO BID	#VALUE!
76-6050 6603 RD Post Shim W/9/16" Hole Wedges	500	NO BID	#VALUE!
Square sign post, 12 ft., 12 gauge, galvanized steel, pre-punched, 1-3/4" x 1-3/4"	1500	NO BID	#VALUE!
U channel galvanized steel post 7 ft. 1.12 lbs.	1500	NO BID	#VALUE!
Square post caps, 5-1/2" blade, flat with set screws	1500	NO BID	#VALUE!
Square post caps, 5-1/2" blade, extruded with set screws	1500	NO BID	#VALUE!
Round post caps for flat with set screws, 2-3/8" post OD for 5-1/2" blade	500	NO BID	#VALUE!
Round post caps for extruded with set screws, 2-3/8" post OD for 5-1/2" blade	500	NO BID	#VALUE!
Small corner bolts	4500	NO BID	#VALUE!
Flanged nuts	4500	NO BID	#VALUE!
Anchors: 1-7/8" x 1-7/8" x 36"	5000	NO BID	#VALUE!
Drive Rivets, 3/8" aluminum	20000	NO BID	#VALUE!
Cross brackets for street signs, 5-1/2" blade holder with set screws for flat	1000	NO BID	#VALUE!
Cross brackets for street signs, 5-1/2" blade holder with set screws for extruded	1000	NO BID	#VALUE!
Cross brackets for street signs, 12" blade holder with set screws for flat	1000	NO BID	#VALUE!
Cross brackets for street signs, 12" blade holder with set screws for extruded	1000	NO BID	#VALUE!
2-7/8" OD, rounded, for flat blades, 5-1/2" blade holder with set screws	1000	NO BID	#VALUE!
2-3/8" OD, round 12" post caps for flat blade with set screws	1000	NO BID	#VALUE!
2-3/8" OD, round 12" post caps for extruded with set screws	1000	NO BID	#VALUE!
12" blade for flat street signs, square post cap, 1-3/4"	1000	NO BID	#VALUE!
12" blade for extruded street signs, square post cap, 1-3/4"	1000	NO BID	#VALUE!
2-3/8" post clamp with fasteners included with each clamp, aluminum	1000	NO BID	#VALUE!
Total Section 3:			#VALUE!

Vendor Name: Osburn Associates, Inc.

Section 4: Construction Supplies	Estimated Annual Quantity	Bid Price per Each	Extended Cost
Barricade, portable type I standard 36" plastic with reflective DG3 diamond grade sheeting with aluminum	200	NO BID	#VALUE!
Barricade, Type III collapsible, diamond grade reflective sheeting, no-maintenance plastic boards, 8 foot, double sided sheeting right and left with Telespar tubing for upright support and legs, 1" thick x 8" tall board	100	NO BID	#VALUE!
Barricade, Type III collapsible, diamond grade reflective sheeting, no-maintenance plastic boards, 10 foot, double sided sheeting right and left with Telespar tubing for upright support and legs, 1" thick x 8" tall board	100	NO BID	#VALUE!
Barricade, Type III collapsible, diamond grade reflective sheeting, no-maintenance plastic boards, 12 foot, double sided sheeting right and left with Telespar tubing for upright support and legs, 1" thick x 8" tall board	100	NO BID	#VALUE!
End of Road barricade boards, Type III with DG3 diamond grade sheeting on no-maintenance plastic boards, 10', red and white, 1" thick x 8" tall board, 3 right boards	100	NO BID	#VALUE!
End of Road barricade boards, Type III with DG3 diamond grade sheeting on no-maintenance plastic boards, 10', red and white, 1" thick x 8" tall board, 3 left boards	100	NO BID	#VALUE!
Barricade, two (2) "A" frames with two (2) 10' diamond grade sheeted I-beams, molded no-maintenance plastic boards, orange and white, right on one side and left on other side	100	NO BID	#VALUE!
Safety cones, 28", orange, 12# weight, 4" upper reflective collars, with white diamond grade VIP reflective sheeting, 14-3/4" x 14-3/4" base	100	NO BID	#VALUE!
Safety cones, 28", orange, 12# weight, 6" upper reflective collars, with white diamond grade VIP reflective sheeting, 14-3/4" x 14-3/4" base	100	NO BID	#VALUE!
Safety cones, 36", orange, 12# weight, 4" upper reflective collars, with white diamond grade VIP reflective sheeting, 14-3/4" x 14-3/4" base	100	NO BID	#VALUE!
Safety cones, 36", orange, 12# weight, 6" upper reflective collars, with white diamond grade VIP reflective sheeting, 14-3/4" x 14-3/4" base	100	NO BID	#VALUE!

Vendor Name:

Section 4: Construction Supplies (cont'd)	Estimated Annual Quantity	Bid Price per each	Extended Cost
Vertical Panel with 20" x 28" black rubber rectangular base, reflective panel 8" x 36", orange and white diagonal sheeting, double sided, diamond grade reflective sheeting,	300	NO BID	#VALUE!
Warning light, Colt RS-600, 6 volt type A	200	NO BID	#VALUE!
Warning light spring battery, general purpose 6 volt type	200	NO BID	#VALUE!
Delineator reflectors, 4" x 4", white aluminum with diamond grade sheeting	2000	NO BID	#VALUE!
Delineator reflectors, 4" x 4", fluorescent yellow aluminum with diamond grade sheeting	2000	NO BID	#VALUE!
Standard roll up construction signs, 48 x 48 reflective, vinyl, plastic corner pockets with ribs with overlays, fluorescent orange. All construction signs in the Texas Manual on Uniform Traffic Control with carrying bags	100	NO BID	#VALUE!
Standard roll up construction signs, 36 x 36 reflective, vinyl, plastic corner pockets with ribs with overlays, fluorescent orange. All construction signs in the Texas Manual on Uniform Traffic Control with carrying bags	50	NO BID	#VALUE!
DF3000W 12" Screwlock Roll-Up Sign Stand	15	NO BID	#VALUE!
DF3003W 12" Screwlock Roll-Up Sign Stand	15	NO BID	#VALUE!
DF3000S 12" Stablock Fold & Roll Sign Stand	15	NO BID	#VALUE!
DF3003S 12" Stablock Fold & Roll Sign Stand	15	NO BID	#VALUE!
DF4503 5" RUB3315 Roll-Up Sign Stand	15	NO BID	#VALUE!
DF4700TX 7" RUB3315 Roll-Up Sign Stand	15	NO BID	#VALUE!
Chip seal markers, white with cover, two sided	5000	NO BID	#VALUE!
Chip seal markers, yellow with cover, two sided	5000	NO BID	#VALUE!
Total Section 4:			#VALUE!

Section 5: Carsonite Products or equal (See Section 1.18 Name Brands)	Estimated Annual Quantity	Bid Price per Each	Extended Cost
Road markers, white, Carsonite CRM-375., flexible 3.75" width x 62" length, with 3" x 12" fluorescent yellow reflective diamond grade VIP installed	1500	\$26.50	\$ 39,750.00
Total Section 5:			\$ 39,750.00

Vendor Name: Osburn Associates, Inc.

Section 6: 3M Products	Estimated Annual Quantity	Bid Price per Each	Extended Cost
Rolls, 30", red, reflective series DG3 cubed, pressure sensitive	20	NO BID	#VALUE!
Rolls, 30" x 50 yd., white, engineer grade, pressure sensitive, #3200T	10	NO BID	#VALUE!
Rolls, 36" x 50 yd., white, engineer grade, pressure sensitive, #3200T	10	NO BID	#VALUE!
Rolls, 9", white, reflective, series DG3 cubed, pressure sensitive	20	NO BID	#VALUE!
Rolls, 24", white, reflective, series DG3 cubed, pressure sensitive	20	NO BID	#VALUE!
Rolls, 30", white, reflective series DG3 cubed, pressure sensitive	20	NO BID	#VALUE!
Rolls, 36", white, reflective series DG3 cubed, pressure sensitive	20	NO BID	#VALUE!
Rolls, 9", yellow, reflective, engineer grade, pressure sensitive, #3200T	5	NO BID	#VALUE!
Rolls, 9", yellow, reflective, series DG3 cubed, pressure sensitive	5	NO BID	#VALUE!
Rolls, 18", yellow, reflective, series DG3 cubed, pressure sensitive	10	NO BID	#VALUE!
Rolls, 24", yellow, reflective, series DG3 cubed, pressure sensitive	10	NO BID	#VALUE!
Rolls, 30", yellow, reflective, series DG3 cubed, pressure sensitive	10	NO BID	#VALUE!
Rolls, 36", yellow, reflective, series DG3 cubed, pressure sensitive	5	NO BID	#VALUE!
Rolls, 9", fluorescent yellow, reflective, series DG3 cubed, pressure sensitive	5	NO BID	#VALUE!
Rolls, 18", fluorescent yellow, reflective, series DG3 cubed, pressure sensitive	5	NO BID	#VALUE!
Rolls, 24", fluorescent yellow, reflective, series DG3 cubed, pressure sensitive	5	NO BID	#VALUE!
Rolls, 30", fluorescent yellow, reflective, series DG3 cubed, pressure sensitive	5	NO BID	#VALUE!
Rolls, 36", fluorescent yellow, reflective, series DG3 cubed, pressure sensitive	5	NO BID	#VALUE!
Rolls, 24", fluorescent yellow green, reflective, series DG3 cubed, pressure sensitive	5	NO BID	#VALUE!
Rolls, 30", fluorescent yellow green, reflective, series DG3 cubed, pressure sensitive	5	NO BID	#VALUE!

Vendor Name:

Section 6: 3M Products (cont'd)	Estimated Annual Quantity	Bid Price per Each	Extended Cost
Rolls, 18", fluorescent orange, reflective, series DG3 cubed, pressure sensitive	6	NO BID	#VALUE!
Rolls, 30", fluorescent orange, reflective, series DG3 cubed, pressure sensitive	6	NO BID	#VALUE!
Rolls, 36", fluorescent orange, reflective, series DG3 cubed, pressure sensitive	6	NO BID	#VALUE!
Rolls, 18", black, non-reflective, vinyl, clear synthetic	5	NO BID	#VALUE!
Rolls, 24", black, non-reflective, vinyl, clear synthetic	5	NO BID	#VALUE!
Rolls, 30", black, non-reflective, vinyl, clear synthetic	5	NO BID	#VALUE!
Rolls, 36", black, non-reflective, vinyl, clear synthetic	5	NO BID	#VALUE!
Rolls, 30", white, non-reflective, vinyl, clear synthetic	10	NO BID	#VALUE!
Rolls, 9", transfer tape, clear	60	NO BID	#VALUE!
Rolls, 12", transfer tape, clear	60	NO BID	#VALUE!
Rolls, 24", transfer tape, clear TPM5 transfer	50	NO BID	#VALUE!
Rolls, 30", transfer tape, clear TPM5	50	NO BID	#VALUE!
Rolls, 36", transfer tape, clear TPM5	50	NO BID	#VALUE!
24", E C film, brown, clear synthetic liner	6	NO BID	#VALUE!
30", E C film, brown, clear synthetic liner	6	NO BID	#VALUE!
24", E C film, green, clear synthetic liner	20	NO BID	#VALUE!
30", E C film, green, clear synthetic liner	6	NO BID	#VALUE!
24", E C film, blue, clear synthetic liner	6	NO BID	#VALUE!
30", E C film, blue, clear synthetic liner	6	NO BID	#VALUE!
24", E C film, red, clear synthetic liner	6	NO BID	#VALUE!
30", E C film, red, clear synthetic liner	6	NO BID	#VALUE!
36", E C film, red, clear synthetic liner	6	NO BID	#VALUE!
2" roll, red/white, conspicuity marking, series DG3 cubed, pressure sensitive, red/white block, 6" x 6", 983-32	6	NO BID	#VALUE!

Vendor Name: Osburn Associates, Inc.

Section 6: 3M Products (cont'd)	Estimated Annual Quantity	Bid Price per Each	Extended Cost
Faces (Faces only NOT complete signs, Does Not include blank) Faces must be pressure sensitive, series DG3 cubed, reflective sheeting and packaged with slip sheeting. Must be packaged with plastic washers.			
Faces: Stop ahead (symbol), 30" fluorescent yellow, series DG3 cubed, material Symbol MUTCD W3-1A	300	NO BID	#VALUE!
Faces: Stop ahead (symbol), 36" fluorescent yellow, series DG3 cubed, material Symbol MUTCD W3-1A	300	NO BID	#VALUE!
Faces: Stop sign, 30 x 30, series DG3 cubed, pre-cut corners	1000	NO BID	#VALUE!
Faces: Stop sign, 36 x 36, series DG3 cubed, pre-cut corners	300	NO BID	#VALUE!
Faces: Yield, 30 x 30	300	NO BID	#VALUE!
Faces: Signals ahead, 30 x 30 fluorescent yellow, series DG3 cubed, Symbol MUTCD W3-3	300	NO BID	#VALUE!
Faces: White body raised pavement markings, one-way white lens, 100 per carton	10	NO BID	#VALUE!
Faces: White body raised pavement markings, two-way white lens, 100 per carton	10	NO BID	#VALUE!
Faces: White body raised pavement markings, two-way white/red lens, 100 per carton	10	NO BID	#VALUE!
Faces: Yellow body raised pavement markings, one-way yellow lens, 100 per carton	10	NO BID	#VALUE!
Faces: Yellow body raised pavement markings, two-way yellow lens, 100 per carton	10	NO BID	#VALUE!
Faces: One way pressure sensitive adhesive raised pavement markers white lens, 100 per carton	10	NO BID	#VALUE!
Faces: One way pressure sensitive adhesive raised pavement markers yellow lens, 100 per carton	10	NO BID	#VALUE!
Faces: One way pressure sensitive adhesive raised pavement markers red lens, 100 per carton	10	NO BID	#VALUE!
Faces: Two way pressure sensitive adhesive raised pavement markers white lens, 100 per carton	10	NO BID	#VALUE!
Faces: Two way pressure sensitive adhesive raised pavement markers yellow lens, 100 per carton	10	NO BID	#VALUE!
3M protective overlay film (series 1160), 30" x 50 yards per roll	10	NO BID	#VALUE!
3M protective overlay film (series 1160), 36" x 50 yards per roll	10	NO BID	#VALUE!
3M citrus base cleaner (aerosol)	100	NO BID	#VALUE!

Vendor Name: Osburn Associates, Inc.

Section 6: 3M Products (cont'd)	Estimated Annual Quantity	Bid Price per Each	Extended Cost
Faces (Faces only NOT complete signs, Does Not include blank)			
Faces must be pressure sensitive, series DG3 cubed, reflective sheeting and packaged with slip sheeting. Must be packaged with plastic washers. Add 3M protective overlay film (series 1160) to each sign face.			
Faces: Stop ahead (symbol), 30" fluorescent yellow, series DG3 cubed, material Symbol MUTCD W3-1A	1000	NO BID	#VALUE!
Faces: Stop ahead (symbol), 36" fluorescent yellow, series DG3 cubed, material Symbol MUTCD W3-1A	1000	NO BID	#VALUE!
Faces: Stop sign, 30 x 30, series DG3 cubed, pre-cut corners	1000	NO BID	#VALUE!
Faces: Stop sign, 36 x 36, series DG3 cubed, pre-cut corners	1000	NO BID	#VALUE!
Faces: Yield, 30 x 30	1000	NO BID	#VALUE!
Faces: Yield, 36 x 36	500	NO BID	#VALUE!
Faces: Signals ahead, 30 x 30 fluorescent yellow, series DG3 cubed, Symbol MUTCD W3-3	1000	NO BID	#VALUE!
Faces: White body raised pavement markings, one-way white lens, 100 per carton	10	NO BID	#VALUE!
Faces: White body raised pavement markings, two-way white lens, 100 per carton	10	NO BID	#VALUE!
Faces: White body raised pavement markings, two-way white/red lens, 100 per carton	10	NO BID	#VALUE!
Faces: Yellow body raised pavement markings, one-way yellow lens, 100 per carton	10	NO BID	#VALUE!
Faces: Yellow body raised pavement markings, two-way yellow lens, 100 per carton	10	NO BID	#VALUE!
Faces: One way pressure sensitive adhesive raised pavement markers white lens, 100 per carton	10	NO BID	#VALUE!
Faces: One way pressure sensitive adhesive raised pavement markers yellow lens, 100 per carton	10	NO BID	#VALUE!
Faces: One way pressure sensitive adhesive raised pavement markers red lens, 100 per carton	10	NO BID	#VALUE!
Faces: Two way pressure sensitive adhesive raised pavement markers white lens, 100 per carton	10	NO BID	#VALUE!
Faces: Two way pressure sensitive adhesive raised pavement markers yellow lens, 100 per carton	10	NO BID	#VALUE!
Total Section 6:			#VALUE!

Vendor Name: Osburn Associates, Inc.

Section 7: Avery Denison	Estimated Annual Quantity	Bid Price per Each	Extended Cost
Rolls, 30" x 50 yd., white, engineer grade, pressure sensitive, #3200T	10	\$277.50	\$ 2,775.00
Rolls, 36" x 50 yd., white, engineer grade, pressure sensitive, #3200T	10	\$333.00	\$ 3,330.00
Rolls, 9", white, reflective, series DG3 cubed, pressure sensitive	20	\$211.50	\$ 4,230.00
Rolls, 24", white, reflective, series DG3 cubed, pressure sensitive	20	\$564.00	\$ 11,280.00
Rolls, 30", white, reflective, series DG3 cubed, pressure sensitive	20	\$705.00	\$ 14,100.00
Rolls, 36", white, reflective, series DG3 cubed, pressure sensitive	20	\$846.00	\$ 16,920.00
Rolls, 9", yellow, reflective, engineer grade, pressure sensitive, #3200T	5	\$83.25	\$ 416.25
Rolls, 9", yellow, reflective, series DG3 cubed, pressure sensitive	5	\$211.50	\$ 1,057.50
Rolls, 18", yellow, reflective, series DG3 cubed, pressure Sensitive	10	\$423.00	\$ 4,230.00
Rolls, 24", yellow, reflective, series DG3 cubed, pressure Sensitive	10	\$564.00	\$ 5,640.00
Rolls, 30", yellow, reflective, series DG3 cubed, pressure Sensitive	10	\$705.00	\$ 7,050.00
Rolls, 36", yellow, reflective, series DG3 cubed, pressure Sensitive	10	\$846.00	\$ 8,460.00
Rolls, 9", fluorescent yellow, reflective, series DG3 cubed, pressure sensitive	10	\$211.50	\$ 2,115.00
Rolls, 18", fluorescent yellow, reflective, series DG3 cubed, pressure sensitive	10	\$423.00	\$ 4,230.00
Rolls, 24", fluorescent yellow, reflective, series DG3 cubed, pressure sensitive	10	\$564.00	\$ 5,640.00
Rolls, 30", fluorescent yellow, reflective, series DG3 cubed, pressure sensitive	10	\$705.00	\$ 7,050.00
Rolls, 36", fluorescent yellow, reflective, series DG3 cubed, pressure sensitive	10	\$846.00	\$ 8,460.00
Rolls, 24", fluorescent yellow green, reflective, series DG3 cubed, pressure sensitive	10	\$564.00	\$ 5,640.00
Rolls, 30", fluorescent yellow green, reflective, series DG3 cubed, pressure sensitive	10	\$705.00	\$ 7,050.00
Rolls, 18", fluorescent orange, reflective, series DG3 cubed, pressure sensitive	10	\$423.00	\$ 4,230.00
Rolls, 30", fluorescent orange, reflective, series DG3 cubed, pressure sensitive	10	\$705.00	\$ 7,050.00

Vendor Name: Osburn Associates, Inc.

Section 7: Avery Denison (cont'd)	Estimated Annual Quantity	Bid Price per Each	Extended Cost
Rolls, 36", fluorescent orange, reflective, series DG3 cubed, pressure sensitive	10	\$846.00	\$ 8,460.00
Rolls, 18", black, non-reflective, vinyl, clear synthetic	10	\$195.75	\$ 1,957.50
Rolls, 24", black, non-reflective, vinyl, clear synthetic	10	\$261.00	\$ 2,610.00
Rolls, 30", black, non-reflective, vinyl, clear synthetic	10	\$326.25	\$ 3,262.50
Rolls, 36", black, non-reflective, vinyl, clear synthetic	10	\$391.50	\$ 3,915.00
Rolls, 30", white, non-reflective, vinyl, clear synthetic	10	326.25	\$ 3,262.50
Rolls, 9", transfer tape, clear	60	39.38	\$ 2,362.80
Rolls, 12", transfer tape, clear	60	45	\$ 2,700.00
24", E C film, brown, clear synthetic liner	6	240	\$ 1,440.00
30", E C film, brown, clear synthetic liner	6	300	\$ 1,800.00
24", E C film, green, clear synthetic liner	6	240	\$ 1,440.00
30", E C film, green, clear synthetic liner	6	300	\$ 1,800.00
24", E C film, blue, clear synthetic liner	6	240	\$ 1,440.00
30", E C film, blue, clear synthetic liner	6	300	\$ 1,800.00
24", E C film, red, clear synthetic liner	6	240	\$ 1,440.00
30", E C film, red, clear synthetic liner	6	300	\$ 1,800.00
36", E C film, red, clear synthetic liner	6	360	\$ 2,160.00
2" roll, red/white, conspicuity marking, series DG3 cubed, pressure sensitive, red/white block, 6" x 6", 983-32	6	58.25	\$ 349.50

Vendor Name: Osburn Associates, Inc.

Section 7: Avery Denison (cont'd)	Estimated Annual Quantity	Bid Price per Each	Extended Cost
Faces (Faces only NOT complete signs, Does Not include blank)			
Faces must be pressure sensitive, series DG3 cubed, reflective sheeting and packaged with slip sheeting. Must be packaged with plastic washers.			
Faces: Stop ahead (symbol), 30" fluorescent yellow, series DG3 cubed, material Symbol MUTCD W3-1A	300	\$12.81	\$ 3,843.00
Faces: Stop sign, 30 x 30, series DG3 cubed, pre-cut corners	1000	\$12.81	\$ 12,810.00
Faces: Stop sign, 36 x 36, series DG3 cubed, pre-cut corners	300	\$18.45	\$ 5,535.00
Faces: Yield, 30 x 30	300	\$7.69	\$ 2,307.00
Faces: Signals ahead, 30 x 30 fluorescent yellow, series DG3 cubed, Symbol MUTCD W3-3	300	\$12.81	\$ 3,843.00
Faces: White body raised pavement markings, one-way white lens, 100 per carton	10	NO BID	#VALUE!
Faces: White body raised pavement markings, two-way white lens, 100 per carton	10	NO BID	#VALUE!
Faces: White body raised pavement markings, two-way white/red lens, 100 per carton	10	NO BID	#VALUE!
Faces: Yellow body raised pavement markings, one-way yellow lens, 100 per carton	10	NO BID	#VALUE!
Faces: Yellow body raised pavement markings, two-way yellow lens, 100 per carton	10	NO BID	#VALUE!
Faces: One way pressure sensitive adhesive raised pavement markers white lens, 100 per carton	10	NO BID	#VALUE!
Faces: One way pressure sensitive adhesive raised pavement markers yellow lens, 100 per carton	10	NO BID	#VALUE!
Faces: One way pressure sensitive adhesive raised pavement markers red lens, 100 per carton	10	NO BID	#VALUE!
Faces: Two way pressure sensitive adhesive raised pavement markers white lens, 100 per carton	10	NO BID	#VALUE!
Faces: Two way pressure sensitive adhesive raised pavement markers yellow lens, 100 per carton	10	NO BID	#VALUE!
Protective overlay film (series 1160), 30" x 50 yards	10	\$270.00	\$ 2,700.00
Protective overlay film (series 1160), 36" x 50 yards	10	\$324.00	\$ 3,240.00
Total Section 7:			#VALUE!

Vendor Name: Osburn Associates, Inc.

Section 8: Cutting Knives	Estimated Annual Quantity	Bid Price per Each	Extended Cost
CB09UA-5 cutting knives for Western Graphtec cutting pro 300-100	25	\$230.50	\$ 5,762.50
CB15U-5 cutting knives for Western Graphtec cutting pro 300-100	25	\$230.50	\$ 5,762.50
Total Section 8:			\$ 11,525.00

Section 9: Banding Materials	Estimated Annual Quantity	Bid Price per Each	Extended Cost
Stainless steel, 3/4" x 100' x .030 coil in dispensing box, type 201 universal	3	\$68.00	\$ 204.00
3/4" wide stainless steel top split wing seal	100	\$0.50	\$ 50.00
Flared leg stainless sign bracket with bolt & washer	100	\$1.75	\$ 175.00
Total Section 9:			\$ 429.00

Vendor Name: Osburn Associates, Inc.

Section 10: Safety Vests	Estimated Annual Quantity	Bid Price per Each	Extended Cost
Safetey vests, ML Kishigo Ultra-Cool mesh, contrasting #1056 (or equal), ANSI/ISEA 107 2010 Class 2 compliant, zipper front closure, 2" wide reflective material with 4.5" contrasting color, inside left chest 2-tier 4-division pencil pocket, lower right inside patch pocket, with Mic Tab on front left chest, with Road and Bridge imprinted on back, Size: M	100	NO BID	#VALUE!
Safetey vests, ML Kishigo Ultra-Cool mesh, contrasting #1056 (or equal), ANSI/ISEA 107 2010 Class 2 compliant, zipper front closure, 2" wide reflective material with 4.5" contrasting color, inside left chest 2-tier 4-division pencil pocket, lower right inside patch pocket, with Mic Tab on front left chest, with Road and Bridge imprinted on back, Size: L	100	NO BID	#VALUE!
Safetey vests, ML Kishigo Ultra-Cool mesh, contrasting #1056 (or equal), ANSI/ISEA 107 2010 Class 2 compliant, zipper front closure, 2" wide reflective material with 4.5" contrasting color, inside left chest 2-tier 4-division pencil pocket, lower right inside patch pocket, with Mic Tab on front left chest, with Road and Bridge imprinted on back, Size: XL	100	NO BID	#VALUE!
Safetey vests, ML Kishigo Ultra-Cool mesh, contrasting #1056 (or equal), ANSI/ISEA 107 2010 Class 2 compliant, zipper front closure, 2" wide reflective material with 4.5" contrasting color, inside left chest 2-tier 4-division pencil pocket, lower right inside patch pocket, with Mic Tab on front left chest, with Road and Bridge imprinted on back, Size: XXL	100	NO BID	#VALUE!
Safetey vests, ML Kishigo Ultra-Cool mesh, contrasting #1056 (or equal), ANSI/ISEA 107 2010 Class 2 compliant, zipper front closure, 2" wide reflective material with 4.5" contrasting color, inside left chest 2-tier 4-division pencil pocket, lower right inside patch pocket, with Mic Tab on front left chest, with Road and Bridge imprinted on back, Size: XXXL	100	NO BID	#VALUE!

Vendor Name:

Section 10: Safety Vests (cont'd)	Estimated Annual Quantity	Bid Price per Each	Extended Cost
Safetey vests, ML Kishigo Ultra-Cool mesh, contrasting #1056 (or equal), ANSI/ISEA 107 2010 Class 2 compliant, zipper front closure, 2" wide reflective material with 4.5" contrasting color, inside left chest 2-tier 4-division pencil pocket, lower right inside patch pocket, with Mic Tab on front left chest, with Road and Bridge imprinted on back, Size: 4XL	100	NO BID	#VALUE!
Safetey vests, ML Kishigo Ultra-Cool mesh, contrasting #1056 (or equal), ANSI/ISEA 107 2010 Class 2 compliant, zipper front closure, 2" wide reflective material with 4.5" contrasting color, inside left chest 2-tier 4-division pencil pocket, lower right inside patch pocket, with Mic Tab on front left chest, with Road and Bridge imprinted on back, Size: 5XL	100	NO BID	#VALUE!
Total Section 10:			#VALUE!

Vendor Name: Osburn Associates, Inc.

Section 11: Stop/Slow Paddles	Estimated Annual Quantity	Bid Price per Each	Extended Cost
Stop/slow paddles, 24" aluminum, Diamond Grade reflective with 12" handle	10	\$138.79	\$ 1,387.90
Extension handles, telescopic with 2 height settings for 6' and 7' height	10	\$28.42	\$ 284.20
Total Section 11:			\$ 1,672.10

Section 12: Miscellaneous	Estimated Annual Quantity	Bid Price per Each	Extended Cost
Yellow water base traffic paint for stripping roads in	1100	NO BID	#VALUE!
White water base traffic paint for stripping roads in	1100	NO BID	#VALUE!
Blue water base traffic paint for stripping roads in gallons	1100	NO BID	#VALUE!
Red water base traffic paint for stripping roads in gallons	1100	NO BID	#VALUE!
Black water base traffic paint for stripping roads in	1100	NO BID	#VALUE!
Glass beads, in pounds, 50 pounds per bag	1000	NO BID	#VALUE!
Bitumem adhesive for raised pavement markings in	5000	NO BID	#VALUE!
Total Section 12:			#VALUE!



COUNTY PURCHASING AGENT
Fort Bend County, Texas

Vendor Information

Jaime Kovar
County Purchasing Agent

Office (281) 341-8640

Legal Company Name (top line of W9)	Trantex Transportation Products of Texas, Inc.	
Business Name (if different from legal name)		
Federal ID # or S.S. #	76-019-1991	DUNS # 11-849-4962
Type of Business	<input checked="" type="checkbox"/> Corporation/LLC <input type="checkbox"/> Partnership <input type="checkbox"/> Sole Proprietor/Individual <input type="checkbox"/> Tax Exempt Organization	Age in Business? 37 years
Publicly Traded Business	<input checked="" type="checkbox"/> No <input type="checkbox"/> Yes Ticker Symbol _____	
Remittance Address	3310-D Frick Rd.	
City/State/Zip	Houston, TX 77086	
Physical Address	3310-D Frick Rd.	
City/State/Zip	Houston, TX 77086	
Phone/Fax Number	Phone: 281-448-7711 Fax: 281-591-6827	
Contact Person	Renee Campbell	
E-mail	renee@trantexinc.com	
Check all that apply to the company listed above and provide certification number.	DBE-Disadvantaged Business Enterprise _____ SBE-Small Business Enterprise _____ HUB -Texas Historically Underutilized Business _____ WBE-Women's Business Enterprise _____	Certification # _____ Certification # _____ Certification # _____ Certification # _____
Company's gross annual receipts	<\$500,000 _____	\$500,000-\$4,999,999 _____
	\$5,000,000-\$16,999,999 <input checked="" type="checkbox"/>	\$17,000,000-\$22,399,999 _____
	>\$22,400,000 _____	
NAICs codes (Please enter all that apply)	423830, 444120, 339950, 423390	
Signature of Authorized Representative		
Printed Name	H. Steven Nelson	
Title	President	
Date	1/14/21	

THIS FORM MUST BE SUBMITTED WITH THE SOLICITATION RESPONSE

Fort Bend County, Texas
Invitation for Bid



Term Contract for the Purchase of Traffic Signs, Posts and Supplies
BID 21-048

SUBMIT BIDS TO:

Fort Bend County
Purchasing Department
Travis Annex
301 Jackson, Suite 201
Richmond, TX 77469

Note: All correspondence must include the term
"Purchasing Department" in address to assist in
proper delivery.

SUBMIT NO LATER THAN:

Tuesday, January 19, 2021
2:00 PM (Central)

LABEL ENVELOPE:

BID 21-048
TRAFFIC SIGNS, POSTS, SUPPLIES

***ALL BIDS MUST BE RECEIVED IN AND TIME/DATE STAMPED BY THE PURCHASING OFFICE
OF FORT BEND COUNTY BEFORE THE SPECIFIED TIME/DATE STATED ABOVE.***

BIDS RECEIVED AS REQUIRED WILL THEN BE OPENED AND PUBLICLY READ.

BIDS RECEIVED AFTER THE SPECIFIED TIME, WILL BE RETURNED UNOPENED.

Results will not be given by phone.
Results will be provided to bidder in writing
after the Commissioners Court awards.

Requests for information must be in
writing and directed to:
Cheryl Krejci, CPPB
Senior Buyer
cheryl.krejci@fortbendcountytexas.gov

Vendor Responsibilities:

- Download and complete any addendums. (Addendums will be posted on the Fort Bend County website no
Later than 48 hours prior to bid opening)
- Submit response in accordance with requirements stated on the cover of this document.
- DO NOT submit responses via email or fax.

1.0 GENERAL REQUIREMENTS:

- 1.1 Read this entire document carefully. Follow all instructions. You are responsible for fulfilling all requirements and specifications. Be sure you understand them.
- 1.2 General Requirements apply to all advertised bids, however, these may be superseded, whole or in part, by the scope, special requirements, specifications, special specifications or other data contained herein.
- 1.3 Governing Law: Bidder is advised that these requirements shall be fully governed by the laws of the State of Texas and that Fort Bend County may request and rely on advice, decisions and opinions of the Attorney General of Texas and the County Attorney concerning any portion of these requirements.
- 1.4 Bid Document Completion: Fill out, initial each page, sign, and return ONE (1) complete bid document to the Fort Bend County Purchasing Department. An authorized representative of the bidder must sign the Contract Sheet. Do not complete the date at the top of the contract sheet. The bid document must be in a sealed envelope marked with the appropriate bid number and title. The contract will be binding only when signed by the County Judge, Fort Bend County and a purchase order authorizing the item(s) desired has been issued. The use of correction fluid is not acceptable and may result in the disqualification of bid. If an error is made, the bidder must draw a line through error and initial each change. All response, typed or written, information must be clear and legible.

If a pricing form in Excel is included and posted on the County's website amongst this bid document, the Vendor must download, complete and save the Excel (not a PDF of the Excel file) file of the pricing form on a CD or flash drive. The Excel file on the CD or flash drive must be downloadable by the Purchasing Department in order to copy and paste the vendor's pricing to the County's tabulation. The CD or flash drive must be labeled and included in the same sealed envelope with the respondent's completed bid document along with a printed copy of the pricing form completed by the vendor.

- 1.5 Bid Returns: Bidders must return completed bid document to the Fort Bend County Purchasing Department at 301 Jackson, Suite 201, Richmond, Texas no later than 2:00 P.M. on the date specified. Late bids will not be accepted. Bids must be submitted in a sealed envelope, addressed as follows: Fort Bend County Purchasing Agent, Travis Annex, 301 Jackson, Suite 201, Richmond, Texas 77469.
- 1.6 Governing Document: In the event of any conflict between the terms and provisions of these requirements and the specifications, the specifications shall govern. In the event of any conflict of interpretation of any part of this overall document, Fort Bend County's interpretation shall govern.

Initials of Bidder: 

- 1.7 Addenda: No interpretation of the meaning of the drawings, specifications or other bid documents will be made to any bidder orally. All requests for such interpretations must be made in writing addressed to Ms. Cheryl Krejci, Senior Buyer, 301 Jackson, Suite 201, Richmond, Texas 77469, e-mail: cheryl.krejci@fortbendcountytexas.gov. Any and all interpretations and any supplemental instructions will be in the form of written addenda to the contract documents which will be posted on Fort Bend County's website. Addenda will **ONLY** be issued by the Fort Bend County Purchasing Agent. It is the sole responsibility of each bidder to insure receipt of any and all addenda. All addenda issued will become part of the contract documents. Bidders must sign and include addendum in the returned bid package. Deadline for submission of questions and/or clarification is **Tuesday, January 12, 2021 at 9:00 a.m. (CST)**. Requests received after the deadline will not be responded to due to the time constraints of this bid process.
- 1.8 Hold Harmless Agreement: Contractor shall indemnify and hold Fort Bend County harmless from all claims for personal injury, death and/or property damage arising from any cause whatsoever, resulting directly or indirectly from contractor's performance. Contractor shall procure and maintain, with respect to the subject matter of this bid, appropriate insurance coverage including, as a minimum, public liability and property damage with adequate limits to cover contractor's liability as may arise directly or indirectly from work performed under terms of this bid. Certification of such coverage must be provided to the County upon request.
- 1.9 Waiver of Subrogation: Bidder and bidder's insurance carrier waive any and all rights whatsoever with regard to subrogation against Fort Bend County as an indirect party to any suit arising out of personal or property damages resulting from bidder's performance under this agreement.
- 1.10 Severability: If any section, subsection, paragraph, sentence, clause, phrase or word of these requirements or the specifications shall be held invalid, such holding shall not affect the remaining portions of these requirements and the specifications and it is hereby declared that such remaining portions would have been included in these requirements and the specifications as though the invalid portion had been omitted.
- 1.11 Bonds: If this bid requires submission of bid guarantee and performance bond, there will be a separate page explaining those requirements. Bids submitted without the required bid bond or cashier's checks are not acceptable. Bond/s or cashier's check must be complete with all required signatures.
- 1.12 Taxes: Fort Bend County is exempt from all federal excise, state and local taxes unless otherwise stated in this document. Fort Bend County claims exemption from all sales and/or use taxes under Chapter 20, Title 122a, Vernon's Texas Civil Statutes, as amended. Texas Limited Sales Tax Exemption Certificates will be furnished upon written request to the Fort Bend County Purchasing Department.

Initials of Bidder: 

- 1.13 Fiscal Funding: A multi-year lease or lease/purchase arrangement (if requested by the specifications), or any contract continuing as a result of an extension option, must include fiscal funding out. If, for any reason, funds are not appropriated to continue the lease or contract, said lease or contract shall become null and void. After expiration of the lease, leased equipment shall be removed by the bidder from the using department without penalty of any kind or form to Fort Bend County. All charges and physical activity related to delivery, installation, removal and redelivery shall be the responsibility of the bidder.
- 1.14 Pricing: Prices for all goods and/or services shall be firm for the duration of this contract and shall be stated in the bid spreadsheet. Prices shall be all inclusive. No price changes, additions, or subsequent qualifications will be honored during the course of the contract. All prices must be written in ink or typewritten. Pricing on all transportation, freight, and other charges are to be prepaid by the contractor and included in the bid prices. If there are any additional charges of any kind, other than those mentioned above, specified or unspecified, bidder MUST indicate the items required and attendant costs or forfeit the right to payment for such items.
- 1.15 Silence of Specifications: The apparent silence of specifications as to any detail, or the apparent omission from it of a detailed description concerning any point, shall be regarded as meaning that only the best commercial practice is to prevail and that only material and workmanship of the finest quality are to be used. All interpretations of specifications shall be made on the basis of this statement. The items furnished under this contract shall be new, unused of the latest product in production to commercial trade and shall be of the highest quality as to materials used and workmanship. Manufacturer furnishing these items shall be experienced in design and construction of such items and shall be an established supplier of the item bid.
- 1.16 Supplemental Materials: Bidders are responsible for including all pertinent product data in the returned bid package. Literature, brochures, data sheets, specification information, completed forms requested as part of the bid package and any other facts which may affect the evaluation and subsequent contract award should be included. Materials such as legal documents and contractual agreements, which the bidder wishes to include as a condition of the bid, must also be in the returned bid package. Failure to include all necessary and proper supplemental materials may be cause to reject the entire bid.
- 1.17 Material Safety Data Sheets: Under the "Hazardous Communication Act", commonly known as the "Texas Right To Know Act", a bidder must provide to County and using departments, with each delivery, material safety data sheets, which are, applicable to hazardous substances defined in the Act. Bidders are obligated to maintain a current, updated file in the Fort Bend County Purchasing Department. Failure of the bidder to maintain such a file will be cause to reject any bid applying thereto.

Initials of Bidder: *Ju*

- 1.18 Name Brands: Specifications may reference name brands and model numbers. It is not the intent of Fort Bend County to restrict these bids in such cases, but to establish a desired quality level of merchandise or to meet a pre-established standard due to like existing items. Bidders may offer items of equal stature and the burden of proof of such stature rests with them. Fort Bend County shall act as sole judge in determining equality and acceptability of products offered.
- 1.19 Color Selection: Determination of colors of materials is a right reserved by the using department unless otherwise specified in the bid. Unspecified colors shall be quoted as standard colors, not colors, which require up charges or special handling. Unspecified fabrics or vinyl should be construed as medium grade. If bidder fails to get color/material approvals prior to delivery of merchandise, the using department may refuse to accept the items and demand correct shipment without penalty, subject to other legal remedies.
- 1.20 Evaluation: Evaluation shall be used as a determinant as to which bid items or services are the most efficient and/or most economical for the County. It shall be based on all factors, which have a bearing on price and performance of the items in the user environment. All bids are subject to tabulation by the Fort Bend County Purchasing Department and recommendation to Fort Bend County Commissioners Court. Compliance with all bid requirements, delivery and needs of the using department are considerations in evaluating bids. Pricing is NOT the only criteria for making a recommendation. The Fort Bend County Purchasing Department reserves the right to contact any bidder, at any time, to clarify, verify or request information with regard to any bid.
- 1.21 Inspections: Fort Bend County reserves the right to inspect any item(s) or service location for compliance with specifications and requirements and needs of the using department. If a bidder cannot furnish a sample of a bid item, where applicable, for review, or fails to satisfactorily show an ability to perform, the County can reject the bid as inadequate.
- 1.22 Testing: Fort Bend County reserves the right to test equipment, supplies, material and goods bid for quality, compliance with specifications and ability to meet the needs of the user. Demonstration units must be available for review. Should the goods or services fail to meet requirements and/or be unavailable for evaluation, the bid is subject to rejection.
- 1.23 Disqualification of Bidder: Upon signing this bid document, a bidder offering to sell supplies, materials, services, or equipment to Fort Bend County certifies that the bidder has not violated the antitrust laws of this state codified in section 15.01, et seq., Business & Commerce Code, or the federal antitrust laws, and has not communicated directly or indirectly the bid made to any competitor or any other person engaged in such line of business. Any or all bids may be rejected if the County believes that collusion exists among the bidders. Bids in which the prices are

Initials of Bidder: *JS*

obviously unbalanced may be rejected. If multiple bids are submitted by a bidder and after the bids are opened, one of the bids is withdrawn, the result will be that all of the bids submitted by that bidder will be withdrawn; however, nothing herein prohibits a vendor from submitting multiple bids for different products or services.

- 1.24 Awards: Fort Bend County reserves the right to award this contract on the basis of lowest and best bid in accordance with the laws of the State of Texas, to waive any formality or irregularity, to make awards to more than one bidder, to reject any or all bids. In the event the lowest dollar bidder meeting specifications is not awarded a contract, the bidder may appear before the Commissioners Court and present evidence concerning his responsibility. An award is final only upon formal execution by the Fort Bend County Commissioners Court or the Fort Bend County Purchasing Agent. Fort Bend County reserves the right to withdraw any award until execution by the proper authority.
- 1.25 Assignment: The successful vendor may not assign, sell or otherwise transfer this contract without written permission of Fort Bend County Commissioners Court.
- 1.26 Term Contracts: If the contract is intended to cover a specific time period, said time will be given in the specifications under scope.
- 1.27 Maintenance: Maintenance required for equipment bid should be available in Fort Bend County by a manufacturer authorized maintenance facility. Costs for this service shall be shown on the bid sheet as requested or on a separate sheet, as required. If Fort Bend County opts to include maintenance, it shall be so stated in the purchase order and said cost will be included. Service will commence only upon expiration of applicable warranties and should be priced accordingly.
- 1.28 Contract Obligation: Fort Bend County Commissioners Court must award the contract and the County Judge or other person authorized by the Fort Bend County Commissioners Court must sign the contract before it becomes binding on Fort Bend County or the bidders. Department heads are not authorized to sign agreements for Fort Bend County. Binding agreements shall remain in effect until all products and/or services covered by this purchase have been satisfactorily delivered and accepted.
- 1.29 Title Transfer: Title and Risk of Loss of goods shall not pass to Fort Bend County until Fort Bend County actually receives and takes possession of the goods at the point or points of delivery. Receiving times may vary with the using department. Generally, deliveries may be made between 8:30 a.m. and 4:00 p.m., Monday through Friday. Bidders are advised to consult the using department for instructions. The place of delivery shall be shown under the "Special Requirement" section of this bid document and/or on the Purchase Order as a "Ship To:" address.
- 1.30 Purchase Order and Delivery: The successful bidder shall not deliver products or

Initials of Bidder: *Ju*

provide services without a Fort Bend County Purchase Order, signed by an authorized agent of the Fort Bend County Purchasing Department. The fastest, most reasonable delivery time shall be indicated by the bidder in the proper place on the bid sheet. Any special information concerning delivery should also be included, on a separate sheet, if necessary. All items shall be shipped F.O.B. inside delivery unless otherwise stated in the specifications. This shall be understood to include bringing merchandise to the appropriate room or place designated by the using department. Every tender or delivery of goods must fully comply with all provisions of these requirements and the specifications including time, delivery and quality. Nonconformance shall constitute a breach, which must be rectified prior to expiration of the time for performance. Failure to rectify within the performance period will be considered cause to reject future deliveries and cancellation of the contract by Fort Bend County without prejudice to other remedies provided by law. Where delivery times are critical, Fort Bend County reserves the right to award accordingly.

- 1.31 Contract Extension: Extensions may be made only by written agreement between Fort Bend County and the bidder. Any price escalations are limited to those stated by the bidder in the original bid.
- 1.32 Termination: Fort Bend County reserves the right to terminate the contract for default if Seller breaches any of the terms therein, including warranties of bidder or if the bidder becomes insolvent or commits acts of bankruptcy. Such right of termination is in addition to and not in lieu of any other remedies, which Fort Bend County may have in law or equity. Default may be construed as, but not limited to, failure to deliver the proper goods and/or services within the proper amount of time, and/or to properly perform any and all services required to Fort Bend County's satisfaction and/or to meet all other obligations and requirements. Contracts may be terminated without cause upon thirty (30) days written notice to either party unless otherwise specified.
- 1.33 Recycled Materials: Fort Bend County encourages the use of products made of recycled materials and shall give preference in purchasing to products made of recycled materials if the products meet applicable specifications as to quantity and quality. Fort Bend County will be the sole judge in determining product preference application.
- 1.34 Interlocal Participation: Additional governmental entities may purchase from this bid. Vendor agrees to accept purchase orders from those participating entities and to invoice each entity separately.
- 1.35 Escalation Clause: Successful bidder may apply for a price increase to the Fort Bend County Purchasing Agent. The County Purchasing Agent will review, and, if increase is deemed warranted, place the request on Fort Bend County's Commissioners Court agenda for their action of approval or disapproval. Approval by the County's Commissioner's Court is required. Any proposed price increase will

Initials of Bidder: *JK*

only be the amount increased to the vendor from his/her supplier. The price increase request must be stated on the vendor's letterhead with the bid number and name in the subject including, in columns, for each item: item description, original bid price, percent of increase, and the total cost of the original bid price including the increased dollar amount. Written documentation from the vendor's supplier of the increase notice must be provided to the Purchasing Agent at time of increase request. No application for a price increase may be submitted within the first six (6) months of this contract. Increase requests of more than 25% of the original bid price will not be considered.

- 1.36 Modifications: This instrument contains the entire Contract between the parties relating to the rights herein granted and obligations herein assumed. Any oral or written representations or modifications concerning this instrument shall be of no force and effect excepting a subsequent written modification signed by both parties hereto.

2.0 TERMS & CONDITIONS:

- 2.1 Seller to Package Goods: Seller will package goods in accordance with good commercial practice. Each delivery container shall be clearly and permanently marked as follows (a) Seller's name and address; (b) Consignee's name, address and purchase order number and the bid number if applicable; (c) Container number and total number of containers (e.g. box 1 of 4 boxes); and (d) the number of the container bearing the packing slip. Seller shall bear cost of packaging unless otherwise provided. Goods shall be suitably packed to secure lowest transportation costs and to conform to requirements of common carriers and any applicable specifications. Fort Bend County's count or weight shall be final and conclusive on shipments not accompanied by packing list.
- 2.2 Shipment Under Reservation Prohibited: Seller is not authorized to ship goods under reservation and no tender of a bill of lading will operate as a tender of goods.
- 2.3 Title and Risk of Loss: The title and risk of loss of the goods shall not pass to the County until a County employee actually receives and takes possession of the goods at the point or points of delivery.
- 2.4 Delivery Terms: F.O.B. Destination Freight Prepaid, Inside Delivery, unless delivery terms are specified otherwise on Purchase Order.
- 2.5 No Replacement of Defective Tender: Every tender or delivery of goods must fully comply with all provisions of the Purchase Order as to time of delivery, quality and the like. If a tender is made which does not fully conform, this shall constitute a breach and Seller shall not have the right to substitute a conforming tender.
- 2.6 Place of Delivery: The place of delivery shall be that set forth in the block of the

Initials of Bidder: 

purchase order entitled "Ship To". Any change thereto shall be effective by modification as provided for in Clause number 2.20 "Modifications", hereof. The terms of this agreement are "no arrival, no sale", at the discretion of Fort Bend County.

2.7 Invoices and Payments:

2.7.1 Seller shall submit separate invoices, in duplicate. Invoices shall indicate the purchase order number and the bid number if applicable. Invoices shall be itemized and transportation charges, if any, shall be listed separately. A copy of the bill of lading, and the freight waybill when applicable should be attached to the invoice.

2.7.2 Fort Bend County's obligation is payable only and solely from funds available for the purpose of this purchase. Lack of funds shall render the order null and void to the extent funds are not available and any delivered but unpaid goods will be returned to Seller by the county.

2.7.3 Do not include Federal Excise, State, or City Sales Tax. Fort Bend County is a tax-exempt governmental entity.

2.8 Gratuities: Fort Bend County may, by written notice to the Seller, cancel any order without liability, if it is determined by the County that gratuities, in the form of entertainment, gifts, or otherwise were offered or given by the Seller, or any agent or representative of the Seller to any officer or employee of Fort Bend County with a view toward securing an order. In the event an order is canceled by the County pursuant to this provision, the County shall be entitled, in addition to any other rights and remedies, to recover or withhold the amount of the cost incurred by Seller in providing such gratuities.

2.9 Special Tools and Test Equipment: If the price stated on the face of an order includes the cost of any special tooling or special test equipment fabricated or required by Seller for the purpose of filing this order, such special tooling equipment and any process sheets related thereto shall become the property of the County and to the extent feasible shall be identified by the Seller as such.

2.10 Warranty/Price:

2.10.1 The price to be paid by the County shall be that contained in Seller's bid which Seller warrants to be no higher than Seller's current prices on orders by others for products of the kind and specification covered by an order for similar quantities under similar or like conditions and methods of purchase. In the event Seller breaches this warranty the prices of the items shall be reduced to the Seller's current prices on orders by others. Fort Bend County may cancel this contract without liability.

Initials of Bidder: 

- 2.10.2 The Seller warrants that no person or selling agency has been employed or retained to solicit or secure any County order based upon any agreement or understanding for commission, percentage, brokerage, or contingent fee excepting bona fide employees of bona fide established commercial or selling agencies maintained by the Seller for the purpose of securing business. A breach or violation of this warranty gives the County the right, in addition to any other right or rights, to cancel this contract without liability.
- 2.11 Warranty Product: Seller shall not limit or exclude any implied warranties and any attempt to do so shall render an order voidable at the option of the County. Seller warrants that the goods furnished will conform to the specifications, drawings, and description listed in the bid invitation and purchase order as applicable, and to the sample(s) furnished by Seller if any. In the event of a conflict between the specifications, drawings, and descriptions, the specifications shall govern.
- 2.12 Safety Warranty: Seller warrants that the product sold to Fort Bend County shall conform to the standards promulgated by the U.S. Department of Labor under the Occupational Safety and Health Act of 1970. In the event the product does not conform to OSHA standards, the County may return the product for correction or replacement at the Seller's expense. In the event Seller fails to make the appropriate correction within 10 days, correction made by the County will be at Seller's expense.
- 2.13 No Warranty by Fort Bend County Against Infringements: As part of a contract for sale Seller agrees to ascertain whether goods manufactured in accordance with the specifications will give rise to the rightful claim of any third person by way of infringement. Fort Bend County makes no warranty that the production of goods according to the specification will not give rise to such a claim and in no event shall Fort Bend County be liable to Seller for indemnification in the event the Seller is sued on the grounds of infringement or the like. If Seller is of the opinion that an infringement will result, he will notify Fort Bend County to this effect in writing within two days after the receiving Purchase Order. If the County does not receive notice and is subsequently held liable for the infringement, Seller will defend and save the County harmless. If Seller in good faith ascertains that production of the goods in accordance with the specifications will result in infringement, this contract shall be null and void except that the County will pay Seller the reasonable cost of his search as to infringements.
- 2.14 Right of Inspection: The County shall have the right to inspect the goods at delivery before accepting them.
- 2.15 Cancellation: Fort Bend County shall have the right to cancel for default all or any part of the undelivered portion of an order if Seller breaches any of the terms hereof including warranties of Seller, or if the Seller becomes insolvent or files for protection under the bankruptcy laws. Such rights of cancellation are in addition to and not in lieu of any other remedies, which Fort Bend County may have in law or

Initials of Bidder: *JA*

equity.

- 2.16 Termination: The performance of work under a Purchase Order may be terminated in whole or in part by the County in accordance with this provision. Termination of work there under shall be effected by the delivery to the Seller of a "Notice of Termination" specifying the extent to which performance of work under the order is terminated and the date upon which such termination becomes effective. Such right of termination is in addition to and not in lieu of rights of Fort Bend County set forth in Clause 15 herein.
- 2.17 Force Majeure: Force Majeure means a delay encountered by a party in the performance of its obligations under this Agreement, which is caused by an event beyond the reasonable control of that party. Without limiting the generality of the foregoing, "Force Majeure" shall include but not be restricted to the following types of events: acts of God or public enemy; acts of governmental or regulatory authorities; fires, floods, epidemics or serious accidents; unusually severe weather conditions; strikes, lockouts, or other labor disputes; and defaults by subcontractors.
- In the event of a Force Majeure, the affected party shall not be deemed to have violated its obligations under this Agreement, and the time for performance of any obligations of that party shall be extended by a period of time necessary to overcome the effects of the Force Majeure, provided that the foregoing shall not prevent this Agreement from terminating in accordance with the termination provisions. If any event constituting a Force Majeure occurs, the affected party shall notify the other parties in writing, within twenty-four (24) hours, and disclose the estimated length of delay, and cause of the delay.
- 2.18 Assignment-Delegation: No right or interest in an order shall be assigned or delegation of any obligation made by Seller without the written permission of Fort Bend County. Any attempted assignment or delegation by Seller shall be wholly void and totally ineffective for all purposes unless made in conformity with this paragraph.
- 2.19 Waiver: No claim or right arising out of a breach of any contract can be discharged in whole or in part by a waiver or renunciation of the claim or right unless the waived or renunciation is supported by consideration and is in writing signed by the aggrieved party.
- 2.20 Modification: A Purchase Order can be modified or rescinded only by a writing signed by both of the parties or their duly authorized agents.
- 2.21 Parol Evidence: This writing is intended by the parties as a final expression of their agreement and is intended also as a complete and exclusive statement of the terms of this agreement. No course of prior dealings between the parties and no usage of the trade shall be relevant to supplement or explain any terms rendered under this agreement and shall not be relevant to determine the meaning of this agreement even

Initials of Bidder: *John*

though the accepting or acquiescing party has knowledge of the performance and opportunity for objection. Whenever a term defined by the Uniform Commercial Code is used in this agreement, the definition contained in the Code is to control.

- 2.22 **Applicable Law:** This agreement shall be governed by the Uniform Commercial Code. Whenever the term "Uniform Commercial Code" is used it shall be construed as meaning the Uniform Commercial Code as adopted in the State of Texas and in effective on the date of the purchase order.
- 2.23 **Advertising:** Seller shall not advertise or publish, without the County's prior consent the fact that Fort Bend County has entered into any contract, except to the extent necessary to comply with proper requests for information from an authorized representative of the federal, state, or local government.
- 2.24 **Right to Assurance:** Whenever the County in good faith has reason to question the other party's intent to perform. The County may demand that the other party give written assurance of his intent to perform. In the event that a demand is made and no assurance is given within five (5) days, the County may treat this failure as an anticipatory repudiation of the contract.
- 2.25 **Venue:** Both parties agree that venue for any litigation arising from this contract shall lie in Richmond, Fort Bend County, Texas.
- 2.26 **Prohibition Against Personal Interest in Contracts:** No officer or employee of the County shall have a financial interest, direct or indirect, in any contract with the County, or shall be financially interested, directly or indirectly, in the sale to the County of any land, materials, supplies, or service, except on behalf of the County as an officer or employee. Any willful violation of this section shall constitute malfeasance in office, and any officer or employee guilty thereof shall be subject to disciplinary action under applicable laws, statutes and codes of the State of Texas. Any violation of this section, with the knowledge, expressed or implied of the person or corporation contracting with the County shall render the contract involved voidable by the County Commissioners Court.

3.0 SCOPE:

It is the intent of Fort Bend County to contract with one (1) or more vendors to provide traffic signs, posts and supplies for Fort Bend County as specified herein.

4.0 TERM OF CONTRACT:

The term of this contract is **April 1, 2021 through March 31, 2022**, renewable annually for four (4) years (through 31 March 2026) under the same terms and conditions if mutually agreeable by both parties. Either party for any reason may terminate this contract by giving thirty (30) days written notice of the intent to terminate.

Initials of Bidder: *JH*

5.0 TEXAS ETHICS COMMISSION FORM 1295:

- 5.1 Effective January 1, 2016 all contracts executed by Commissioners Court, regardless of the dollar amount, will require completion of Form 1295 "Certificate of Interested Parties", per the new Government Code Statute §2252.908. All vendors submitting a response to a formal Bid, RFP, SOQ or any contracts, contract amendments, renewals or change orders are required to complete the Form 1295 online through the State of Texas Ethics Commission website. Please visit: https://www.ethics.state.tx.us/whatsnew/elf_info_form1295.htm.
- 5.2 On-line instructions:
 - 5.2.1 Name of governmental entity is to read: Fort Bend County.
 - 5.2.2 Identification number used by the governmental entity is: B21-048.
 - 5.2.3 Description is the title of the solicitation: Traffic Signs, Posts, Supplies.
- 5.3 Apparent low bidder(s) will be required to provide the Form 1295 within three (3) calendar days from notification; however, if your company is publicly traded you are not required to complete this form.

6.0 STATE LAW REQUIREMENTS FOR CONTRACTS:

The contents of this section are required by Texas Law and are included by County regardless of content.

- 6.1 Agreement to Not Boycott Israel Chapter 2270 Texas Government Code: By signature on vendor form, Contractor verifies Contractor does not boycott Israel and will not boycott Israel during the term of this Contract.
- 6.2 Texas Government Code Section 2251.152 Acknowledgment: By signature on vendor form, Contractor represents pursuant to Section 2252.152 of the Texas Government Code, that Contractor is not listed on the website of the Comptroller of the State of Texas concerning the listing of companies that are identified under Section 806.051, Section 807.051 or Section 2253.153.

7.0 HUMAN TRAFFICKING:

By acceptance of this contract, Contractor acknowledges that Fort Bend County is opposed to human trafficking and that no County funds will be used in support of services or activities that violate human trafficking laws.

Initials of Bidder: 

8.0 ASSIGNMENT:

Contractor shall not sell, assign, transfer or convey these services, in whole or in part, without the prior written consent of Fort Bend County and as a condition of such consent, contractor shall remain liable for completion of the services in the event of default by the successor contractor or assignee.

9.0 AWARD:

This contract will be awarded to the lowest and best bidder per section.

10.0 GENERAL:

- 10.1 Quantities listed are estimates only. Fort Bend County does not guarantee the quantities stated will be purchased.
- 10.2 No minimum orders, by quantity or dollar amount.
- 10.3 Bidders may be required to submit samples for inspection and evaluation after bid opening to determine acceptability.

11.0 DELIVERY:

- 11.1 Vendor must complete delivery within thirty (30) working days after receipt of purchase order.
- 11.2 The successful bidder shall not deliver products without a Purchase Order issued by the Fort Bend County Purchasing Agent.
- 11.3 The successful bidder shall not deliver products or services in excess of those authorized and under no circumstances will Fort Bend County be liable for payment of products or services, which exceed the amounts authorized by the purchase order.
- 11.4 All orders must be delivered between 8:00 AM and 3:00 PM, Monday through Friday to the address indicated on purchase order.

12.0 SPECIFICATIONS and BID PRICING:

Specifications are located in the Excel pricing form downloadable from Fort Bend County's website. Provide bid prices in the electronic Excel file and return as stated in Section 1.4 and 1.5.

13.0 QUALITY CONTROL:

Fort Bend County reserves the right to sample and test products at time of delivery for specification compliance in the presence of the driver or vendor's representative. Costs for tests shall be borne by the Contractor in the event product fails to meet specifications. Products not in their original

Initials of Bidder: 

package will not be accepted.

14.0 REQUIRED FORMS:

All vendors submitting are required to complete and provide with submission:

- 14.1 Electronic Excel file of Pricing Form on CD or flash drive and printed hard copy
- 14.2 Vendor Form
- 14.3 W9 Form
- 14.4 Tax Form/Debt/Residence Certification

Initials of Bidder: 

Contract Sheet
Bid 21-048

THE STATE OF TEXAS
COUNTY OF FORT BEND

This memorandum of agreement made and entered into on the 23rd day of March, 2021
by and between Fort Bend County in the State of Texas (hereinafter designated County), acting herein by
County Judge KP George, by virtue of an order of Fort Bend County Commissioners Court, and
Trantex Transportation Products of Texas, Inc. (hereinafter designated Contractor).
(company name)

WITNESSETH:

The Contractor and the County agree that the bid and specifications for the **Purchase of Traffic Signs, Posts and Supplies** which are hereto attached and made a part hereof, together with this instrument and the bond (when required) shall constitute the full agreement and contract between parties and for furnishing the items set out and described; the County agrees to pay the prices stipulated in the accepted bid.

It is further agreed that this contract shall not become binding or effective until signed by the parties hereto and a purchase order authorizing the items desired has been issued.

Executed at Richmond, Texas this 23 day of March 2021.

KP George Fort Bend County, Texas
By: _____ County Judge KP George
County Judge, KP George

[Signature]
By: _____
Signature of Contractor

By: H. Steven Nelson President
Printed Name and Title

COUNTY PURCHASING AGENT

Fort Bend County, Texas



Jaime Kovar
County Purchasing Agent

(281) 341-8640
Fax (281) 341-8645

January 4, 2021

TO: All Prospective Bidders

RE: Addendum No. 1 – Fort Bend County Bid 21-048 – Traffic Signs, Posts & Supplies

Addendum 1:

Attached is addendum 1. Vendors are to use Addendum 1 document while preparing their solicitation response. Contract name updated on Contract Sheet, page 17.

Immediately upon your receipt of this addendum, please fill out the following information and email this page to Jessica Carabajal at jessica.carabajal@fortbendcountytexas.gov

Trantex Transportation Products of Texas, Inc.

Company Name

[Handwritten Signature]

1/14/21

Signature of person receiving addendum

Date

If you have any questions, please contact this office.

Sincerely,

[Handwritten Signature]

Cheryl Krejci
Senior Buyer

Request for Taxpayer Identification Number and Certification

**Give Form to the
 requester. Do not
 send to the IRS.**

▶ Go to www.irs.gov/FormW9 for instructions and the latest information.

Print or type.
 See Specific Instructions on page 3.

1 Name (as shown on your income tax return). Name is required on this line; do not leave this line blank. Trantex Transportation Products of Texas Inc.	
2 Business name/disregarded entity name, if different from above	
3 Check appropriate box for federal tax classification of the person whose name is entered on line 1. Check only one of the following seven boxes. <input type="checkbox"/> Individual/sole proprietor or single-member LLC <input checked="" type="checkbox"/> C Corporation <input type="checkbox"/> S Corporation <input type="checkbox"/> Partnership <input type="checkbox"/> Trust/estate <input type="checkbox"/> Limited liability company. Enter the tax classification (C=C corporation, S=S corporation, P=Partnership) ▶ _____ Note: Check the appropriate box in the line above for the tax classification of the single-member owner. Do not check LLC if the LLC is classified as a single-member LLC that is disregarded from the owner unless the owner of the LLC is another LLC that is not disregarded from the owner for U.S. federal tax purposes. Otherwise, a single-member LLC that is disregarded from the owner should check the appropriate box for the tax classification of its owner. <input type="checkbox"/> Other (see instructions) ▶ _____	4 Exemptions (codes apply only to certain entities, not individuals; see instructions on page 3): Exempt payee code (if any) _____ Exemption from FATCA reporting code (if any) _____ <i>(Applies to accounts maintained outside the U.S.)</i>
5 Address (number, street, and apt. or suite no.) See instructions. 3310 Frick Rd. Bldg. D	Requester's name and address (optional)
6 City, state, and ZIP code Houston, TX 77086	
7 List account number(s) here (optional)	

Part I Taxpayer Identification Number (TIN)																																																							
Enter your TIN in the appropriate box. The TIN provided must match the name given on line 1 to avoid backup withholding. For individuals, this is generally your social security number (SSN). However, for a resident alien, sole proprietor, or disregarded entity, see the instructions for Part I, later. For other entities, it is your employer identification number (EIN). If you do not have a number, see <i>How to get a TIN</i> , later. Note: If the account is in more than one name, see the instructions for line 1. Also see <i>What Name and Number To Give the Requester</i> for guidelines on whose number to enter.	<table border="1" style="width: 100%; border-collapse: collapse;"> <tr> <td colspan="10" style="text-align: center;">Social security number</td> </tr> <tr> <td style="width: 25px; height: 25px;"></td> <td style="width: 25px; height: 25px;"></td> <td style="width: 25px; height: 25px;"></td> <td style="width: 25px; height: 25px;"></td> <td style="width: 25px; height: 25px;"></td> <td style="width: 25px; height: 25px;"></td> <td style="width: 25px; height: 25px;"></td> <td style="width: 25px; height: 25px;"></td> <td style="width: 25px; height: 25px;"></td> <td style="width: 25px; height: 25px;"></td> </tr> <tr> <td colspan="3" style="text-align: center;">-</td> <td colspan="4"></td> <td colspan="3" style="text-align: center;">-</td> <td colspan="3"></td> </tr> </table> <p style="text-align: center; margin: 5px 0;">or</p> <table border="1" style="width: 100%; border-collapse: collapse;"> <tr> <td colspan="10" style="text-align: center;">Employer identification number</td> </tr> <tr> <td style="width: 25px; height: 25px; text-align: center;">7</td> <td style="width: 25px; height: 25px; text-align: center;">6</td> <td style="width: 25px; height: 25px;"></td> <td style="width: 25px; height: 25px; text-align: center;">-</td> <td style="width: 25px; height: 25px; text-align: center;">0</td> <td style="width: 25px; height: 25px; text-align: center;">1</td> <td style="width: 25px; height: 25px; text-align: center;">9</td> <td style="width: 25px; height: 25px; text-align: center;">1</td> <td style="width: 25px; height: 25px; text-align: center;">9</td> <td style="width: 25px; height: 25px; text-align: center;">9</td> <td style="width: 25px; height: 25px; text-align: center;">1</td> </tr> </table>	Social security number																				-							-						Employer identification number										7	6		-	0	1	9	1	9	9	1
Social security number																																																							
-							-																																																
Employer identification number																																																							
7	6		-	0	1	9	1	9	9	1																																													

Part II Certification	
Under penalties of perjury, I certify that:	
1. The number shown on this form is my correct taxpayer identification number (or I am waiting for a number to be issued to me); and 2. I am not subject to backup withholding because: (a) I am exempt from backup withholding, or (b) I have not been notified by the Internal Revenue Service (IRS) that I am subject to backup withholding as a result of a failure to report all interest or dividends, or (c) the IRS has notified me that I am no longer subject to backup withholding; and 3. I am a U.S. citizen or other U.S. person (defined below); and 4. The FATCA code(s) entered on this form (if any) indicating that I am exempt from FATCA reporting is correct.	
Certification instructions. You must cross out item 2 above if you have been notified by the IRS that you are currently subject to backup withholding because you have failed to report all interest and dividends on your tax return. For real estate transactions, item 2 does not apply. For mortgage interest paid, acquisition or abandonment of secured property, cancellation of debt, contributions to an individual retirement arrangement (IRA), and generally, payments other than interest and dividends, you are not required to sign the certification, but you must provide your correct TIN. See the instructions for Part II, later.	
Sign Here	Signature of U.S. person ▶ <i>Renee Campbell</i>
Date ▶ <i>1-5-2021</i>	

General Instructions

Section references are to the Internal Revenue Code unless otherwise noted.

Future developments. For the latest information about developments related to Form W-9 and its instructions, such as legislation enacted after they were published, go to www.irs.gov/FormW9.

Purpose of Form

An individual or entity (Form W-9 requester) who is required to file an information return with the IRS must obtain your correct taxpayer identification number (TIN) which may be your social security number (SSN), individual taxpayer identification number (ITIN), adoption taxpayer identification number (ATIN), or employer identification number (EIN), to report on an information return the amount paid to you, or other amount reportable on an information return. Examples of information returns include, but are not limited to, the following.

- Form 1099-INT (interest earned or paid)
- Form 1099-DIV (dividends, including those from stocks or mutual funds)
- Form 1099-MISC (various types of income, prizes, awards, or gross proceeds)
- Form 1099-B (stock or mutual fund sales and certain other transactions by brokers)
- Form 1099-S (proceeds from real estate transactions)
- Form 1099-K (merchant card and third party network transactions)
- Form 1098 (home mortgage interest), 1098-E (student loan interest), 1098-T (tuition)
- Form 1099-C (canceled debt)
- Form 1099-A (acquisition or abandonment of secured property)

Use Form W-9 only if you are a U.S. person (including a resident alien), to provide your correct TIN.

If you do not return Form W-9 to the requester with a TIN, you might be subject to backup withholding. See What is backup withholding, later.

Job No.: B21-048

TAX FORM/DEBT/ RESIDENCE CERTIFICATION
(for Advertised Projects)

Taxpayer Identification Number (T.I.N.): 76-019-1991

Company Name submitting Bid/Proposal: Trantex Transportation Products of Texas, Inc.

Mailing Address: 3310-D Frick Rd. Houston, TX 77086

Are you registered to do business in the State of Texas? Yes No

If you are an individual, list the names and addresses of any partnership of which you are a general partner or any assumed name(s) under which you operate your business

I. **Property:** List all taxable property in Fort Bend County owned by you or above partnerships as well as any d/b/a names. Include real and personal property as well as mineral interest accounts. (Use a second sheet of paper if necessary.)

<u>Fort Bend County Tax Acct. No.*</u>	<u>Property address or location**</u>
<u>None</u>	<u>None</u>
_____	_____
_____	_____
_____	_____

* This is the property account identification number assigned by the Fort Bend County Appraisal District.
** For real property, specify the property address or legal description. For business personal property, specify the address where the property is located. For example, office equipment will normally be at your office, but inventory may be stored at a warehouse or other location.

II. **Fort Bend County Debt** - Do you owe any debts to Fort Bend County (taxes on properties listed in I above, tickets, fines, tolls, court judgments, etc.)?
Yes No If yes, attach a separate page explaining the debt.

III. **Residence Certification** - Pursuant to Texas Government Code §2252.001 *et seq.*, as amended, Fort Bend County requests Residence Certification. §2252.001 *et seq.* of the Government Code provides some restrictions on the awarding of governmental contracts; pertinent provisions of §2252.001 are stated below:

- (3) "Nonresident bidder" refers to a person who is not a resident.
- (4) "Resident bidder" refers to a person whose principal place of business is in this state, including a contractor whose ultimate parent company or majority owner has its principal place of business in this state.

I certify that Trantex Transportation Products of Texas, Inc. is a Resident Bidder of Texas as defined in Government Code §2252.001.
[Company Name]

I certify that _____ is a Nonresident Bidder as defined in Government Code §2252.001 and our principal place of business is _____.
[City and State]

Fort Bend County Pricing Form
BID 21-048
Term Contract for Traffic Signs, Posts and Supplies

Vendor Name: Trantex Transportation Products of Texas

Section 1: Complete Signs Finished traffic signs must be .080 aluminum with faces, diamond grade, VIP, reflective sheeting. Add 3M protective overlay film (series 1160) to each sign.	Estimated Annual Quantity	Bid Price per Each	Extended Cost
All way, 18 x 6, red white VIP diamond Grade (MUTCD R1-4)	400	No Bid	#VALUE!
Watch for ice on bridge, 36 x 36, hinged with closure hook, fluorescent yellow, diamond grade material	100	No Bid	#VALUE!
Type III, 12x36, fluorescent yellow, DG3, (MUTCD OM-3R)	50	No Bid	#VALUE!
Type III, 12x36, fluorescent yellow, DG3, (MUTCD OM-3L)	50	No Bid	#VALUE!
Total Section 1:			#VALUE!

Vendor Name: Trantex Transportation Products of Texas

Section 6: 3M Products (cont'd)	Estimated Annual Quantity	Bid Price per Each	Extended Cost
Faces (Faces only NOT complete signs, Does Not include blank) Faces must be pressure sensitive, series DG3 cubed, reflective sheeting and packaged with slip sheeting. Must be packaged with plastic washers.			
Faces: Stop ahead (symbol), 30" fluorescent yellow, series DG3 cubed, material Symbol MUTCD W3-1A	300	No Bid	#VALUE!
Faces: Stop ahead (symbol), 36" fluorescent yellow, series DG3 cubed, material Symbol MUTCD W3-1A	300	No Bid	#VALUE!
Faces: Stop sign, 30 x 30, series DG3 cubed, pre-cut corners	1000	No Bid	#VALUE!
Faces: Stop sign, 36 x 36, series DG3 cubed, pre-cut corners	300	No Bid	#VALUE!
Faces: Yield, 30 x 30	300	No Bid	#VALUE!
Faces: Signals ahead, 30 x 30 fluorescent yellow, series DG3 cubed, Symbol MUTCD W3-3	300	No Bid	#VALUE!
Faces: White body raised pavement markings, one-way white lens, 100 per carton	10	No Bid	#VALUE!
Faces: White body raised pavement markings, two-way white lens, 100 per carton	10	No Bid	#VALUE!
Faces: White body raised pavement markings, two-way white/red lens, 100 per carton	10	No Bid	#VALUE!
Faces: Yellow body raised pavement markings, one-way yellow lens, 100 per carton	10	No Bid	#VALUE!
Faces: Yellow body raised pavement markings, two-way yellow lens, 100 per carton	10	No Bid	#VALUE!
Faces: One way pressure sensitive adhesive raised pavement markers white lens, 100 per carton	10	No Bid	#VALUE!
Faces: One way pressure sensitive adhesive raised pavement markers yellow lens, 100 per carton	10	No Bid	#VALUE!
Faces: One way pressure sensitive adhesive raised pavement markers red lens, 100 per carton	10	No Bid	#VALUE!
Faces: Two way pressure sensitive adhesive raised pavement markers white lens, 100 per carton	10	No Bid	#VALUE!
Faces: Two way pressure sensitive adhesive raised pavement markers yellow lens, 100 per carton	10	No Bid	#VALUE!
3M protective overlay film (series 1160), 30" x 50 yards per roll	10	No Bid	#VALUE!
3M protective overlay film (series 1160), 36" x 50 yards per roll	10	No Bid	#VALUE!
3M citrus base cleaner (aerosol)	100	No Bid	#VALUE!

Vendor Name: Trantex Transportation Products of Texas

Section 6: 3M Products (cont'd)	Estimated Annual Quantity	Bid Price per Each	Extended Cost
Faces (Faces only NOT complete signs, Does Not include blank) Faces must be pressure sensitive, series DG3 cubed, reflective sheeting and packaged with slip sheeting. Must be packaged with plastic washers. Add 3M protective overlay film (series 1160) to each sign face.			
Faces: Stop ahead (symbol), 30" fluorescent yellow, series DG3 cubed, material Symbol MUTCD W3-1A	1000	No Bid	#VALUE!
Faces: Stop ahead (symbol), 36" fluorescent yellow, series DG3 cubed, material Symbol MUTCD W3-1A	1000	No Bid	#VALUE!
Faces: Stop sign, 30 x 30, series DG3 cubed, pre-cut corners	1000	No Bid	#VALUE!
Faces: Stop sign, 36 x 36, series DG3 cubed, pre-cut corners	1000	No Bid	#VALUE!
Faces: Yield, 30 x 30	1000	No Bid	#VALUE!
Faces: Yield, 36 x 36	500	No Bid	#VALUE!
Faces: Signals ahead, 30 x 30 fluorescent yellow, series DG3 cubed, Symbol MUTCD W3-3	1000	No Bid	#VALUE!
Faces: White body raised pavement markings, one-way white lens, 100 per carton	10	No Bid	#VALUE!
Faces: White body raised pavement markings, two-way white lens, 100 per carton	10	No Bid	#VALUE!
Faces: White body raised pavement markings, two-way white/red lens, 100 per carton	10	No Bid	#VALUE!
Faces: Yellow body raised pavement markings, one-way yellow lens, 100 per carton	10	No Bid	#VALUE!
Faces: Yellow body raised pavement markings, two-way yellow lens, 100 per carton	10	No Bid	#VALUE!
Faces: One way pressure sensitive adhesive raised pavement markers white lens, 100 per carton	10	No Bid	#VALUE!
Faces: One way pressure sensitive adhesive raised pavement markers yellow lens, 100 per carton	10	No Bid	#VALUE!
Faces: One way pressure sensitive adhesive raised pavement markers red lens, 100 per carton	10	No Bid	#VALUE!
Faces: Two way pressure sensitive adhesive raised pavement markers white lens, 100 per carton	10	No Bid	#VALUE!
Faces: Two way pressure sensitive adhesive raised pavement markers yellow lens, 100 per carton	10	No Bid	#VALUE!
Total Section 6:			#VALUE!

Vendor Name: Trantex Transportation Products of Texas

Section 7: Avery Denison	Estimated Annual Quantity	Bid Price per Each	Extended Cost
Rolls, 30" x 50 yd., white, engineer grade, pressure sensitive, #3200T	10	No Bid	#VALUE!
Rolls, 36" x 50 yd., white, engineer grade, pressure sensitive, #3200T	10	No Bid	#VALUE!
Rolls, 9", white, reflective, series DG3 cubed, pressure sensitive	20	No Bid	#VALUE!
Rolls, 24", white, reflective, series DG3 cubed, pressure sensitive	20	No Bid	#VALUE!
Rolls, 30", white, reflective, series DG3 cubed, pressure sensitive	20	No Bid	#VALUE!
Rolls, 36", white, reflective, series DG3 cubed, pressure sensitive	20	No Bid	#VALUE!
Rolls, 9", yellow, reflective, engineer grade, pressure sensitive, #3200T	5	No Bid	#VALUE!
Rolls, 9", yellow, reflective, series DG3 cubed, pressure sensitive	5	No Bid	#VALUE!
Rolls, 18", yellow, reflective, series DG3 cubed, pressure Sensitive	10	No Bid	#VALUE!
Rolls, 24", yellow, reflective, series DG3 cubed, pressure Sensitive	10	No Bid	#VALUE!
Rolls, 30", yellow, reflective, series DG3 cubed, pressure Sensitive	10	No Bid	#VALUE!
Rolls, 36", yellow, reflective, series DG3 cubed, pressure Sensitive	10	No Bid	#VALUE!
Rolls, 9", fluorescent yellow, reflective, series DG3 cubed, pressure sensitive	10	No Bid	#VALUE!
Rolls, 18", fluorescent yellow, reflective, series DG3 cubed, pressure sensitive	10	No Bid	#VALUE!
Rolls, 24", fluorescent yellow, reflective, series DG3 cubed, pressure sensitive	10	No Bid	#VALUE!
Rolls, 30", fluorescent yellow, reflective, series DG3 cubed, pressure sensitive	10	No Bid	#VALUE!
Rolls, 36", fluorescent yellow, reflective, series DG3 cubed, pressure sensitive	10	No Bid	#VALUE!
Rolls, 24", fluorescent yellow green, reflective, series DG3 cubed, pressure sensitive	10	No Bid	#VALUE!
Rolls, 30", fluorescent yellow green, reflective, series DG3 cubed, pressure sensitive	10	No Bid	#VALUE!
Rolls, 18", fluorescent orange, reflective, series DG3 cubed, pressure sensitive	10	No Bid	#VALUE!
Rolls, 30", fluorescent orange, reflective, series DG3 cubed, pressure sensitive	10	No Bid	#VALUE!

Vendor Name: Trantex Transportation Products of Texas

Section 7: Avery Denison (cont'd)	Estimated Annual Quantity	Bid Price per Each	Extended Cost
Rolls, 36", fluorescent orange, reflective, series DG3 cubed, pressure sensitive	10	No Bid	#VALUE!
Rolls, 18", black, non-reflective, vinyl, clear synthetic	10	No Bid	#VALUE!
Rolls, 24", black, non-reflective, vinyl, clear synthetic	10	No Bid	#VALUE!
Rolls, 30", black, non-reflective, vinyl, clear synthetic	10	No Bid	#VALUE!
Rolls, 36", black, non-reflective, vinyl, clear synthetic	10	No Bid	#VALUE!
Rolls, 30", white, non-reflective, vinyl, clear synthetic	10	No Bid	#VALUE!
Rolls, 9", transfer tape, clear	60	No Bid	#VALUE!
Rolls, 12", transfer tape, clear	60	No Bid	#VALUE!
24", E C film, brown, clear synthetic liner	6	No Bid	#VALUE!
30", E C film, brown, clear synthetic liner	6	No Bid	#VALUE!
24", E C film, green, clear synthetic liner	6	No Bid	#VALUE!
30", E C film, green, clear synthetic liner	6	No Bid	#VALUE!
24", E C film, blue, clear synthetic liner	6	No Bid	#VALUE!
30", E C film, blue, clear synthetic liner	6	No Bid	#VALUE!
24", E C film, red, clear synthetic liner	6	No Bid	#VALUE!
30", E C film, red, clear synthetic liner	6	No Bid	#VALUE!
36", E C film, red, clear synthetic liner	6	No Bid	#VALUE!
2" roll, red/white, conspicuity marking, series DG3 cubed, pressure sensitive, red/white block, 6" x 6", 983-32	6	No Bid	#VALUE!

Vendor Name: Trantex Transportation Products of Texas

Section 7: Avery Denison (cont'd)	Estimated Annual Quantity	Bid Price per Each	Extended Cost
Faces (Faces only NOT complete signs, Does Not include blank) Faces must be pressure sensitive, series DG3 cubed, reflective sheeting and packaged with slip sheeting. Must be packaged with plastic washers.			
Faces: Stop ahead (symbol), 30" fluorescent yellow, series DG3 cubed, material Symbol MUTCD W3-1A	300	No Bid	#VALUE!
Faces: Stop sign, 30 x 30, series DG3 cubed, pre-cut corners	1000	No Bid	#VALUE!
Faces: Stop sign, 36 x 36, series DG3 cubed, pre-cut corners	300	No Bid	#VALUE!
Faces: Yield, 30 x 30	300	No Bid	#VALUE!
Faces: Signals ahead, 30 x 30 fluorescent yellow, series DG3 cubed, Symbol MUTCD W3-3	300	No Bid	#VALUE!
Faces: White body raised pavement markings, one-way white lens, 100 per carton	10	No Bid	#VALUE!
Faces: White body raised pavement markings, two-way white lens, 100 per carton	10	No Bid	#VALUE!
Faces: White body raised pavement markings, two-way white/red lens, 100 per carton	10	No Bid	#VALUE!
Faces: Yellow body raised pavement markings, one-way yellow lens, 100 per carton	10	No Bid	#VALUE!
Faces: Yellow body raised pavement markings, two-way yellow lens, 100 per carton	10	No Bid	#VALUE!
Faces: One way pressure sensitive adhesive raised pavement markers white lens, 100 per carton	10	No Bid	#VALUE!
Faces: One way pressure sensitive adhesive raised pavement markers yellow lens, 100 per carton	10	No Bid	#VALUE!
Faces: One way pressure sensitive adhesive raised pavement markers red lens, 100 per carton	10	No Bid	#VALUE!
Faces: Two way pressure sensitive adhesive raised pavement markers white lens, 100 per carton	10	No Bid	#VALUE!
Faces: Two way pressure sensitive adhesive raised pavement markers yellow lens, 100 per carton	10	No Bid	#VALUE!
Protective overlay film (series 1160), 30" x 50 yards	10	No Bid	#VALUE!
Protective overlay film (series 1160), 36" x 50 yards	10	No Bid	#VALUE!
Total Section 7:			#VALUE!

Vendor Name: Trantex Transportation Products of Texas

Section 8: Cutting Knives	Estimated Annual Quantity	Bid Price per Each	Extended Cost
CB09UA-5 cutting knives for Western Graphtec cutting pro 300-100	25	No Bid	#VALUE!
CB15U-5 cutting knives for Western Graphtec cutting pro 300-100	25	No Bid	#VALUE!
Total Section 8:			#VALUE!

Section 9: Banding Materials	Estimated Annual Quantity	Bid Price per Each	Extended Cost
Stainless steel, 3/4" x 100' x .030 coil in dispensing box, type 201 universal	3	No Bid	#VALUE!
3/4" wide stainless steel top split wing seal	100	No Bid	#VALUE!
Flared leg stainless sign bracket with bolt & washer	100	No Bid	#VALUE!
Total Section 9:			#VALUE!

Vendor Name: Trantex Transportation Products of Texas

Section 10: Safety Vests	Estimated Annual Quantity	Bid Price per Each	Extended Cost
Safety vests, ML Kishigo Ultra-Cool mesh, contrasting #1056 (or equal), ANSI/ISEA 107 2010 Class 2 compliant, zipper front closure, 2" wide reflective material with 4.5" contrasting color, inside left chest 2-tier 4-division pencil pocket, lower right inside patch pocket, with Mic Tab on front left chest, with Road and Bridge imprinted on back, Size: M	100	\$14.70	\$ 1,470.00
Safety vests, ML Kishigo Ultra-Cool mesh, contrasting #1056 (or equal), ANSI/ISEA 107 2010 Class 2 compliant, zipper front closure, 2" wide reflective material with 4.5" contrasting color, inside left chest 2-tier 4-division pencil pocket, lower right inside patch pocket, with Mic Tab on front left chest, with Road and Bridge imprinted on back, Size: L	100	\$14.70	\$ 1,470.00
Safety vests, ML Kishigo Ultra-Cool mesh, contrasting #1056 (or equal), ANSI/ISEA 107 2010 Class 2 compliant, zipper front closure, 2" wide reflective material with 4.5" contrasting color, inside left chest 2-tier 4-division pencil pocket, lower right inside patch pocket, with Mic Tab on front left chest, with Road and Bridge imprinted on back, Size: XL	100	\$14.70	\$ 1,470.00
Safety vests, ML Kishigo Ultra-Cool mesh, contrasting #1056 (or equal), ANSI/ISEA 107 2010 Class 2 compliant, zipper front closure, 2" wide reflective material with 4.5" contrasting color, inside left chest 2-tier 4-division pencil pocket, lower right inside patch pocket, with Mic Tab on front left chest, with Road and Bridge imprinted on back, Size: XXL	100	\$14.70	\$ 1,470.00
Safety vests, ML Kishigo Ultra-Cool mesh, contrasting #1056 (or equal), ANSI/ISEA 107 2010 Class 2 compliant, zipper front closure, 2" wide reflective material with 4.5" contrasting color, inside left chest 2-tier 4-division pencil pocket, lower right inside patch pocket, with Mic Tab on front left chest, with Road and Bridge imprinted on back, Size: XXXL	100	\$14.70	\$ 1,470.00

Vendor Name: Trantex Transportation Products of Texas

Section 10: Safety Vests (cont'd)	Estimated Annual Quantity	Bid Price per Each	Extended Cost
Safetey vests, ML Kishigo Ultra-Cool mesh, contrasting #1056 (or equal), ANSI/ISEA 107 2010 Class 2 compliant, zipper front closure, 2" wide reflective material with 4.5" contrasting color, inside left chest 2-tier 4-division pencil pocket, lower right inside patch pocket, with Mic Tab on front left chest, with Road and Bridge imprinted on back, Size: 4XL	100	\$14.70	\$ 1,470.00
Safetey vests, ML Kishigo Ultra-Cool mesh, contrasting #1056 (or equal), ANSI/ISEA 107 2010 Class 2 compliant, zipper front closure, 2" wide reflective material with 4.5" contrasting color, inside left chest 2-tier 4-division pencil pocket, lower right inside patch pocket, with Mic Tab on front left chest, with Road and Bridge imprinted on back, Size: 5XL	100	\$14.70	\$ 1,470.00
Total Section 10:			\$ 10,290.00

Vendor Name: Trantex Transportation Products of Texas

Section 11: Stop/Slow Paddles	Estimated Annual Quantity	Bid Price per Each	Extended Cost
Stop/slow paddles, 24" aluminum, Diamond Grade reflective with 12" handle	10	\$89.00	\$ 890.00
Extension handles, telescopic with 2 height settings for 6' and 7' height	10	\$16.75	\$ 167.50
Total Section 11:			\$ 1,057.50

Section 12: Miscellaneous	Estimated Annual Quantity	Bid Price per Each	Extended Cost
Yellow water base traffic paint for stripping roads in	1100	\$14.55	\$ 16,005.00
White water base traffic paint for stripping roads in	1100	\$14.35	\$ 15,785.00
Blue water base traffic paint for stripping roads in gallons	1100	\$10.50	\$ 11,550.00
Red water base traffic paint for stripping roads in gallons	1100	\$11.95	\$ 13,145.00
Black water base traffic paint for stripping roads in gallons	1100	\$10.10	\$ 11,110.00
Glass beads, in pounds, 50 pounds per bag	1000	\$0.82	\$ 820.00
Bitumem adhesive for raised pavement markings in	5000	\$0.40	\$ 2,000.00
Total Section 12:			\$ 70,415.00

Vendor Name: Trantex Transportation Products of Texas

Section 2: Blanks Blanks must be .080 aluminum	Estimated Annual Quantity	Bid Price per Each	Extended Cost
Blanks, rounded corners, diamond punch 18 x 18	1000	No Bid	#VALUE!
Blanks, rounded corners, diamond punch 24 x 24	1000	No Bid	#VALUE!
Blanks, rounded corners, diamond punch 30 x 30	1000	No Bid	#VALUE!
Blanks, rounded corners, diamond punch 36 x 36	500	No Bid	#VALUE!
Blanks, octagon 30 x 30	1000	No Bid	#VALUE!
Blanks, octagon 36 x 36	300	No Bid	#VALUE!
Blanks, pentagon 30 x 30	300	No Bid	#VALUE!
Blanks, pentagon 36 x 36	65	No Bid	#VALUE!
Blanks, rounded corners, rectangle 24 x 8	400	No Bid	#VALUE!
Blanks, rounded corners, rectangle 24 x 10	400	No Bid	#VALUE!
Blanks, rounded corners, rectangle 24 x 12	400	No Bid	#VALUE!
Blanks, rounded corners, rectangle 12 x 18	400	No Bid	#VALUE!
Blanks, rounded corners, rectangle 18 x 24	400	No Bid	#VALUE!
Blanks, rounded corners, rectangle 24 x 30	1000	No Bid	#VALUE!
Blanks, rounded corners, rectangle 24 x 36	300	No Bid	#VALUE!
Blanks, rounded corners, rectangle 30 x 36	100	No Bid	#VALUE!
Blanks, rounded corners, rectangle 24 x 48	500	No Bid	#VALUE!
Blanks, rounded corners, rectangle 30 x 48	100	No Bid	#VALUE!
Blanks, rounded corners, rectangle 36 x 18	500	No Bid	#VALUE!
Blanks, rounded corners, square 18 x 18	1000	No Bid	#VALUE!
Blanks, rounded corners, square 24 x 24	1000	No Bid	#VALUE!
Blanks, rounded corners, street sign, flat, 9 x 30	600	No Bid	#VALUE!
Blanks, rounded corners, street sign, flat, 9 x 36	600	No Bid	#VALUE!
Blanks, rounded corners, street sign, flat, 9 x 42	600	No Bid	#VALUE!
Blanks, rounded corners, street sign, flat, 9 x 48	600	No Bid	#VALUE!
Blanks, round, 36" diameter	300	No Bid	#VALUE!
Blanks, rounded corners, rectangle, 10 x 30	300	No Bid	#VALUE!
Blanks, rounded corners, rectangle, 12 x 30	300	No Bid	#VALUE!
Blanks, rounded corners, triangle, 30	500	No Bid	#VALUE!
Blanks, rounded corners, triangle, 36	500	No Bid	#VALUE!
Blanks, extruded, 9 x 30	1000	No Bid	#VALUE!
Blanks, extruded, 9 x 36	1000	No Bid	#VALUE!
Blanks, extruded, 9 x 42	1000	No Bid	#VALUE!
Blanks, extruded, 9 x 48	1000	No Bid	#VALUE!
Blanks, extruded, 9 x 54	1000	No Bid	#VALUE!
Total Section 2:			#VALUE!

Vendor Name: Trantex Transportation Products of Texas

Section 3: Posts and Accessories-Telespar Sign Support System	Estimated Annual Quantity	Bid Price per Each	Extended Cost
12' Round 2.375 16 gauge galvanized post	500	17.30	\$ 8,650.00
14' 1-3/4"x1-3/4" square 12 gauge galvanized sign post	500	41.50	\$ 20,750.00
12" round post cap flat blade for 2.375" round post	500	6.35	\$ 3,175.00
12" round post cap extruded for 2.375" round post	500	6.35	\$ 3,175.00
**74-5606 TRF RD RW 2.375 16 gauge Post, 12'	500	\$17.30	\$ 8,650.00
75-4892 TRF RD Taper 2.875 Poz Loc Sockets	500	\$11.50	\$ 5,750.00
76-6050 6603 RD Post Shim W/9/16" Hole Wedges	500	\$3.25	\$ 1,625.00
Square sign post, 12 ft., 12 gauge, galvanized steel, pre-punched, 1-3/4" x 1-3/4"	1500	\$40.50	\$ 60,750.00
U channel galvanized steel post 7 ft. 1.12 lbs.	1500	\$7.00	\$ 10,500.00
Square post caps, 5-1/2" blade, flat with set screws	1500	\$2.75	\$ 4,125.00
Square post caps, 5-1/2" blade, extruded with set screws	1500	\$2.75	\$ 4,125.00
Round post caps for flat with set screws, 2-3/8" post OD for 5-1/2" blade	500	\$3.00	\$ 1,500.00
Round post caps for extruded with set screws, 2-3/8" post OD for 5-1/2" blade	500	\$3.00	\$ 1,500.00
Small corner bolts	4500	\$0.27	\$ 1,215.00
Flanged nuts	4500	\$0.07	\$ 315.00
Anchors: 1-7/8" x 1-7/8" x 36"	5000	\$11.75	\$ 58,750.00
Drive Rivets, 3/8" aluminum	20000	\$0.78	\$ 15,600.00
Cross brackets for street signs, 5-1/2" blade holder with set screws for flat	1000	\$3.25	\$ 3,250.00
Cross brackets for street signs, 5-1/2" blade holder with set screws for extruded	1000	\$3.25	\$ 3,250.00
Cross brackets for street signs, 12" blade holder with set screws for flat	1000	\$6.75	\$ 6,750.00
Cross brackets for street signs, 12" blade holder with set screws for extruded	1000	\$6.75	\$ 6,750.00
2-7/8" OD, rounded, for flat blades, 5-1/2" blade holder with set screws	1000	\$4.75	\$ 4,750.00
2-3/8" OD, round 12" post caps for flat blade with set screws	1000	\$5.25	\$ 5,250.00
2-3/8" OD, round 12" post caps for extruded with set screws	1000	\$5.25	\$ 5,250.00
12" blade for flat street signs, square post cap, 1-3/4"	1000	\$6.35	\$ 6,350.00
12" blade for extruded street signs, square post cap, 1-3/4"	1000	\$6.35	\$ 6,350.00
2-3/8" post clamp with fasteners included with each clamp, aluminum	1000	\$2.75	\$ 2,750.00
Total Section 3:			\$ 260,855.00

Vendor Name: Trantex Transportation Products of Texas

Section 4: Construction Supplies	Estimated Annual Quantity	Bid Price per Each	Extended Cost
Barricade, portable type I standard 36" plastic with reflective DG3 diamond grade sheeting with aluminum	200	\$62.50	\$ 12,500.00
Barricade, Type III collapsible, diamond grade reflective sheeting, no-maintenance plastic boards, 8 foot, double sided sheeting right and left with Telespar tubing for upright support and legs, 1" thick x 8" tall board	100	\$308.50	\$ 30,850.00
Barricade, Type III collapsible, diamond grade reflective sheeting, no-maintenance plastic boards, 10 foot, double sided sheeting right and left with Telespar tubing for upright support and legs, 1" thick x 8" tall board	100	\$369.00	\$ 36,900.00
Barricade, Type III collapsible, diamond grade reflective sheeting, no-maintenance plastic boards, 12 foot, double sided sheeting right and left with Telespar tubing for upright support and legs, 1" thick x 8" tall board	100	\$435.00	\$ 43,500.00
End of Road barricade boards, Type III with DG3 diamond grade sheeting on no-maintenance plastic boards, 10', red and white, 1" thick x 8" tall board, 3 right boards	100	\$103.50	\$ 10,350.00
End of Road barricade boards, Type III with DG3 diamond grade sheeting on no-maintenance plastic boards, 10', red and white, 1" thick x 8" tall board, 3 left boards	100	\$103.50	\$ 10,350.00
Barricade, two (2) "A" frames with two (2) 10' diamond grade sheeted I-beams, molded no-maintenance plastic boards, orange and white, right on one side and left on other side	100	\$242.50	\$ 24,250.00
Safety cones, 28", orange, 12# weight, 4" upper reflective collars, with white diamond grade VIP reflective sheeting, 14-3/4" x 14-3/4" base	100	\$18.50	\$ 1,850.00
Safety cones, 28", orange, 12# weight, 6" upper reflective collars, with white diamond grade VIP reflective sheeting, 14-3/4" x 14-3/4" base	100	\$18.50	\$ 1,850.00
Safety cones, 36", orange, 12# weight, 4" upper reflective collars, with white diamond grade VIP reflective sheeting, 14-3/4" x 14-3/4" base	100	\$19.50	\$ 1,950.00
Safety cones, 36", orange, 12# weight, 6" upper reflective collars, with white diamond grade VIP reflective sheeting, 14-3/4" x 14-3/4" base	100	\$19.50	\$ 1,950.00

Vendor Name: Trantex Transportation Products of Texas

Section 4: Construction Supplies (cont'd)	Estimated Annual Quantity	Bid Price per each	Extended Cost
Vertical Panel with 20" x 28" black rubber rectangular base, reflective panel 8" x 36", orange and white diagonal sheeting, double sided, diamond grade reflective sheeting,	300	\$47.50	\$ 14,250.00
Warning light, Colt RS-600, 6 volt type A	200	\$14.00	\$ 2,800.00
Warning light spring battery, general purpose 6 volt type	200	\$5.00	\$ 1,000.00
Delineator reflectors, 4" x 4", white aluminum with diamond grade sheeting	2000	\$2.15	\$ 4,300.00
Delineator reflectors, 4" x 4", fluorescent yellow aluminum with diamond grade sheeting	2000	\$2.15	\$ 4,300.00
Standard roll up construction signs, 48 x 48 reflective, vinyl, plastic corner pockets with ribs with overlays, fluorescent orange. All construction signs in the Texas Manual on Uniform Traffic Control with carrying bags	100	\$122.50	\$ 12,250.00
Standard roll up construction signs, 36 x 36 reflective, vinyl, plastic corner pockets with ribs with overlays, fluorescent orange. All construction signs in the Texas Manual on Uniform Traffic Control with carrying bags	50	\$97.50	\$ 4,875.00
DF3000W 12" Screwlock Roll-Up Sign Stand	15	\$105.00	\$ 1,575.00
DF3003W 12" Screwlock Roll-Up Sign Stand	15	\$110.00	\$ 1,650.00
DF3000S 12" Stablock Fold & Roll Sign Stand	15	\$108.00	\$ 1,620.00
DF3003S 12" Stablock Fold & Roll Sign Stand	15	\$112.00	\$ 1,680.00
DF4503 5" RUB3315 Roll-Up Sign Stand	15	\$180.00	\$ 2,700.00
DF4700TX 7" RUB3315 Roll-Up Sign Stand	15	\$200.00	\$ 3,000.00
Chip seal markers, white with cover, two sided	5000	\$0.45	\$ 2,250.00
Chip seal markers, yellow with cover, two sided	5000	\$0.45	\$ 2,250.00
Total Section 4:			\$ 236,800.00

Section 5: Carsonite Products or equal (See Section 1.18 Name Brands)	Estimated Annual Quantity	Bid Price per Each	Extended Cost
Road markers, white, Carsonite CRM-375., flexible 3.75" width x 62" length, with 3" x 12" fluorescent yellow reflective diamond grade VIP installed	1500	\$11.95	\$ 17,925.00
Total Section 5:			\$ 17,925.00

Vendor Name: Trantex Transportation Products of Texas

Section 6: 3M Products	Estimated Annual Quantity	Bid Price per Each	Extended Cost
Rolls, 30", red, reflective series DG3 cubed, pressure sensitive	20	No Bid	#VALUE!
Rolls, 30" x 50 yd., white, engineer grade, pressure sensitive, #3200T	10	No Bid	#VALUE!
Rolls, 36" x 50 yd., white, engineer grade, pressure sensitive, #3200T	10	No Bid	#VALUE!
Rolls, 9", white, reflective, series DG3 cubed, pressure sensitive	20	No Bid	#VALUE!
Rolls, 24", white, reflective, series DG3 cubed, pressure sensitive	20	No Bid	#VALUE!
Rolls, 30", white, reflective series DG3 cubed, pressure sensitive	20	No Bid	#VALUE!
Rolls, 36", white, reflective series DG3 cubed, pressure sensitive	20	No Bid	#VALUE!
Rolls, 9", yellow, reflective, engineer grade, pressure sensitive, #3200T	5	No Bid	#VALUE!
Rolls, 9", yellow, reflective, series DG3 cubed, pressure sensitive	5	No Bid	#VALUE!
Rolls, 18", yellow, reflective, series DG3 cubed, pressure sensitive	10	No Bid	#VALUE!
Rolls, 24", yellow, reflective, series DG3 cubed, pressure sensitive	10	No Bid	#VALUE!
Rolls, 30", yellow, reflective, series DG3 cubed, pressure sensitive	10	No Bid	#VALUE!
Rolls, 36", yellow, reflective, series DG3 cubed, pressure sensitive	5	No Bid	#VALUE!
Rolls, 9", fluorescent yellow, reflective, series DG3 cubed, pressure sensitive	5	No Bid	#VALUE!
Rolls, 18", fluorescent yellow, reflective, series DG3 cubed, pressure sensitive	5	No Bid	#VALUE!
Rolls, 24", fluorescent yellow, reflective, series DG3 cubed, pressure sensitive	5	No Bid	#VALUE!
Rolls, 30", fluorescent yellow, reflective, series DG3 cubed, pressure sensitive	5	No Bid	#VALUE!
Rolls, 36", fluorescent yellow, reflective, series DG3 cubed, pressure sensitive	5	No Bid	#VALUE!
Rolls, 24", fluorescent yellow green, reflective, series DG3 cubed, pressure sensitive	5	No Bid	#VALUE!
Rolls, 30", fluorescent yellow green, reflective, series DG3 cubed, pressure sensitive	5	No Bid	#VALUE!

Vendor Name: Trantex Transportation Products of Texas

Section 6: 3M Products (cont'd)	Estimated Annual Quantity	Bid Price per Each	Extended Cost
Rolls, 18", fluorescent orange, reflective, series DG3 cubed, pressure sensitive	6	No Bid	#VALUE!
Rolls, 30", fluorescent orange, reflective, series DG3 cubed, pressure sensitive	6	No Bid	#VALUE!
Rolls, 36", fluorescent orange, reflective, series DG3 cubed, pressure sensitive	6	No Bid	#VALUE!
Rolls, 18", black, non-reflective, vinyl, clear synthetic	5	No Bid	#VALUE!
Rolls, 24", black, non-reflective, vinyl, clear synthetic	5	No Bid	#VALUE!
Rolls, 30", black, non-reflective, vinyl, clear synthetic	5	No Bid	#VALUE!
Rolls, 36", black, non-reflective, vinyl, clear synthetic	5	No Bid	#VALUE!
Rolls, 30", white, non-reflective, vinyl, clear synthetic	10	No Bid	#VALUE!
Rolls, 9", transfer tape, clear	60	No Bid	#VALUE!
Rolls, 12", transfer tape, clear	60	No Bid	#VALUE!
Rolls, 24", transfer tape, clear TPM5 transfer	50	No Bid	#VALUE!
Rolls, 30", transfer tape, clear TPM5	50	No Bid	#VALUE!
Rolls, 36", transfer tape, clear TPM5	50	No Bid	#VALUE!
24", E C film, brown, clear synthetic liner	6	No Bid	#VALUE!
30", E C film, brown, clear synthetic liner	6	No Bid	#VALUE!
24", E C film, green, clear synthetic liner	20	No Bid	#VALUE!
30", E C film, green, clear synthetic liner	6	No Bid	#VALUE!
24", E C film, blue, clear synthetic liner	6	No Bid	#VALUE!
30", E C film, blue, clear synthetic liner	6	No Bid	#VALUE!
24", E C film, red, clear synthetic liner	6	No Bid	#VALUE!
30", E C film, red, clear synthetic liner	6	No Bid	#VALUE!
36", E C film, red, clear synthetic liner	6	No Bid	#VALUE!
2" roll, red/white, conspicuity marking, series DG3 cubed, pressure sensitive, red/white block, 6" x 6", 983-32	6	No Bid	#VALUE!

ECONOCADE TYPE I & TYPE II BARRICADE

Economical,
All Plastic Alternative
to Steel Leg Barricades



- One piece solid construction
- Easy to handle, pack, and transport
- Rust free and impact resistant
- Bottom rail can carry a sand bag
- Two flashing light mounting receptacles
- Available in white, custom colors available
- MASH Accepted, WZ-407
- Meets MUTCD Standards



Signs or names can be stenciled
directly on the barricade

PLASTICADE®

Plasticade.com

ECONOCADE[®]

TYPE I & TYPE II BARRICADE

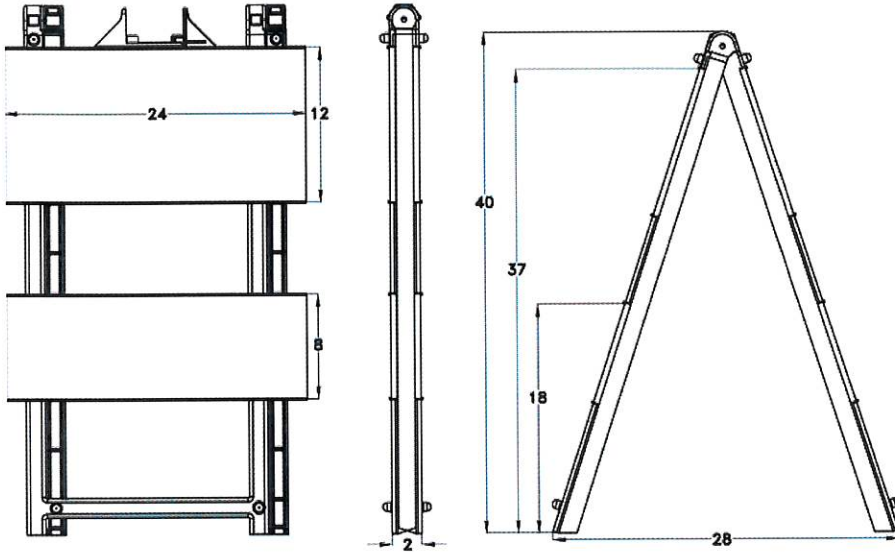

Specs

Composition	High Density Polyethylene
Dimensions	42.6"H x 24.4"W
Color	White
Weight	13.2 lbs.
Reflective Sheeting	Available in all grades in white and orange



PLASTICADE[™]

100 Howard Avenue
Des Plaines, IL 60018
phone (800) 772-0355
fax (847) 966-8074
Plasticade.com

MADE IN THE USA



A-FRAME BARRICADES

Two Options:
Both great for crowd control
and road closures

OMNI™ A-FRAME BARRICADE



- Versatile, accepts many types of boards
 - Plasticade® I-Beam boards
 - Plasticade® 1" x 8" boards (Type III boards)
 - other plastic boards (I-Beams, thin rails, panels)
 - wood boards
- 20% heavier than Plasticade® A-Frame
 - solid wall design
- Customize nameplate with your name or logo
- Stacking lugs
 - make transportation and storage easy
- Flashing light mounting receptacle on leg
- Use with one board or two
- Sold in sets or as component parts

PLASTICADE® A-FRAME BARRICADE



- Accepts only Plasticade® I-Beam boards
- Molded hollow
 - may be weighed internally with dry sand
- Stacking lugs
 - make transportation and storage easy
- Flashing light mounting receptacle on leg
- Use with one board or two
- Sold in sets or as component parts



I-Beam Board

I-Beam Boards have a unique design that adds to the rigidity of the unit. The recessed area for sheeting helps to protect the sheeting from damage.



1" x 8" Board

1" x 8" Boards are a hollow core extruded design. Internal walls provide lightweight strength and durability.

PLASTICADE

www.plasticade.com

TF034

A-FRAME BARRICADES

OMNI™ A-FRAME BARRICADE

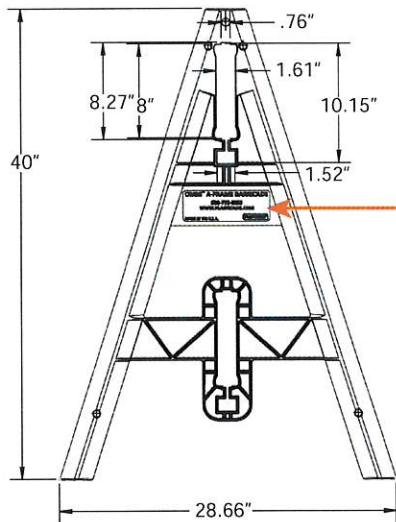

Customize the Omni™ A-Frame Leg with molded-in name or logo. Nameplate area is 7.38" W x 2.6" H

Omni™ Specs

Composition	High Density Polyethylene
Dimensions	40"H x 28.6"W
Color	White, custom colors available
Weight	6 lbs.
Available I-Beam Board Lengths	6' 8' 10'
Available 1" x 8" Board Lengths	4', 6', 8' 10', 12'

PLASTICADE® A-FRAME BARRICADE

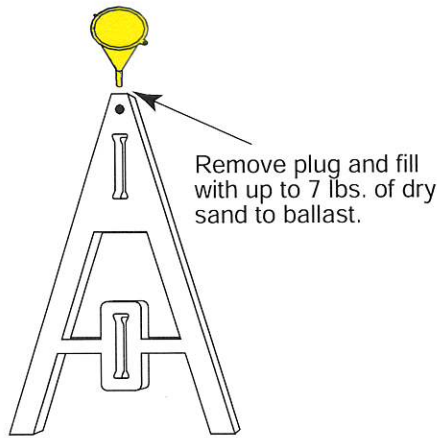
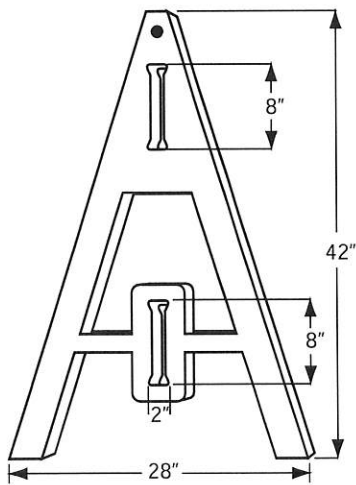

Plasticade® Specs

Composition	High Density Polyethylene
Dimensions	42"H x 28"W
Color	White
Weight	5 lbs.
Available I-Beam Board Lengths	6' 8' 10'

PLASTICADE®

7700 N. Austin Avenue
Skokie, IL 60077
phone (800) 772-0355
fax (847) 966-8074

www.plasticade.com

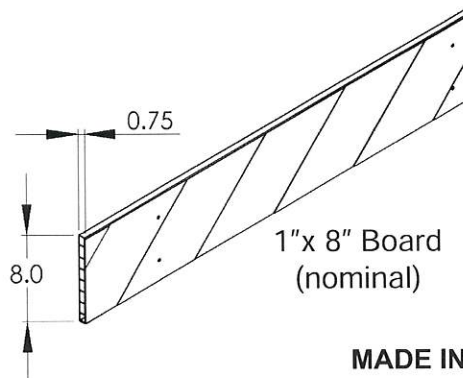
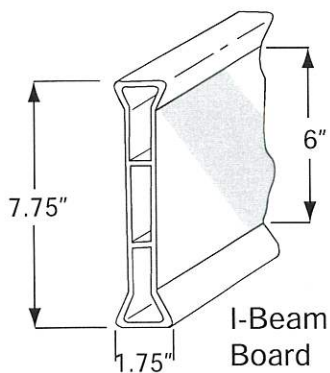

MADE IN THE USA

TELESPAR[®] & ANGLE IRON TYPE III BARRICADES

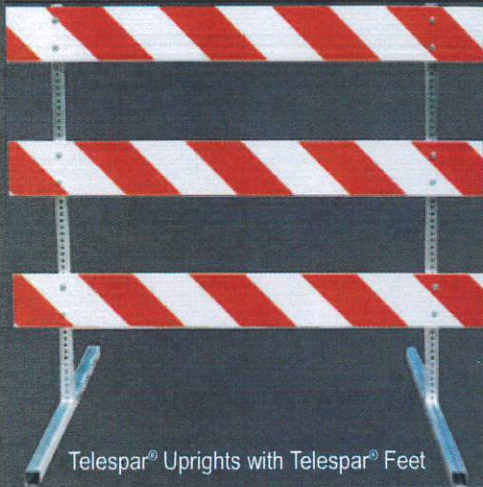

Telespar[®] Uprights with Telespar[®] Feet

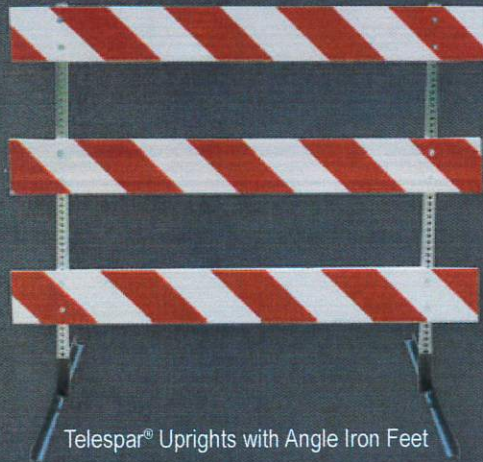

Telespar[®] Uprights with Angle Iron Feet

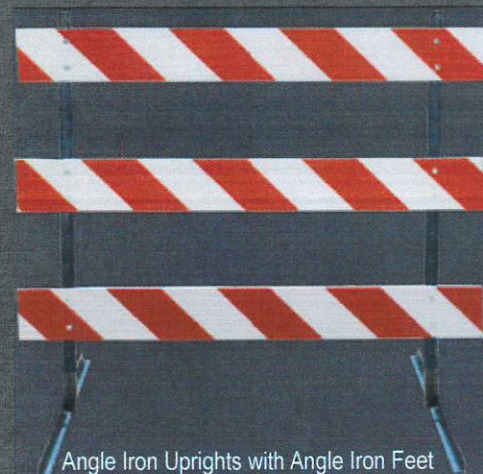

Angle Iron Uprights with Angle Iron Feet

Three Options Available

- Telespar[®] uprights with Telespar[®] feet
 - Telespar[®] uprights with Angle Iron feet
 - Angle Iron uprights with Angle Iron feet
-
- **Telespar[®]**
 - Square shape provides superior wind load capabilities and inhibits warping
 - Uprights and feet - 14 gauge
 - Galvanized, hot rolled high carbon steel
 - Prepunched universal mounting holes - 7/16" dia.
 - **Angle Iron**
 - Uprights are 10 gauge, galvanized steel
 - Holes for boards - 11/32" dia., holes for lights 9/16" dia.
 - Feet are 10 gauge steel, mill finish
 - Plastic boards available in 4', 6', 8', 10', and 12' lengths
 - Reflective sheeting on one or both sides
 - Quick removal of uprights from feet
 - Allows for short term or permanent placement
 - Easy to assemble and replace parts if necessary
 - Accepts two flashing lights
 - NCHRP-350 Accepted, Meets MUTCD Standards

PLASTICADE[®]

www.plasticade.com

TF016 Rev. 3

TELESPAR® & ANGLE IRON TYPE III BARRICADES

Telespar® Barricade

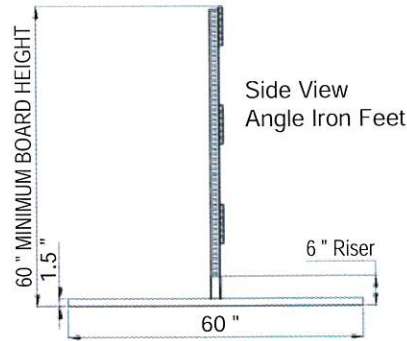
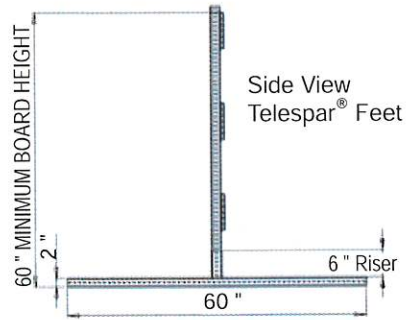
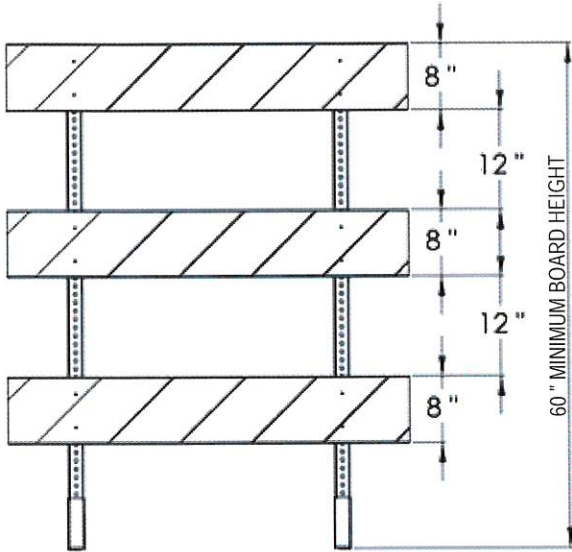

Specs

Telespar	14 gauge galvanized
Angle Iron Upright	10 gauge galvanized
Angle Iron Feet	10 gauge mill finish
Board Composition	High Density Polyethylene
Available Board Sizes	1" x 8" x 4' 1" x 8" x 6' 1" x 8" x 8' 1" x 8" x 10' 1" x 8" x 12'
Reflective Sheeting	Available in all grades - in left, right, or chevron stripes

Angle Iron Barricade

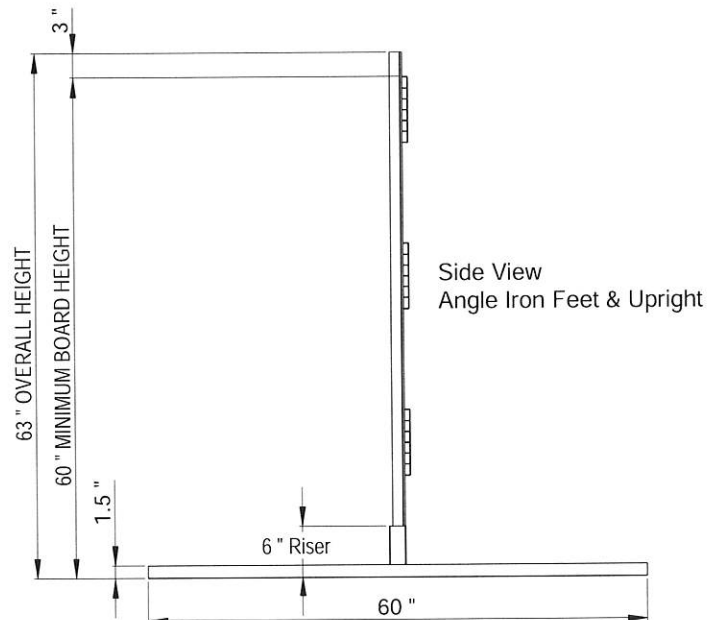
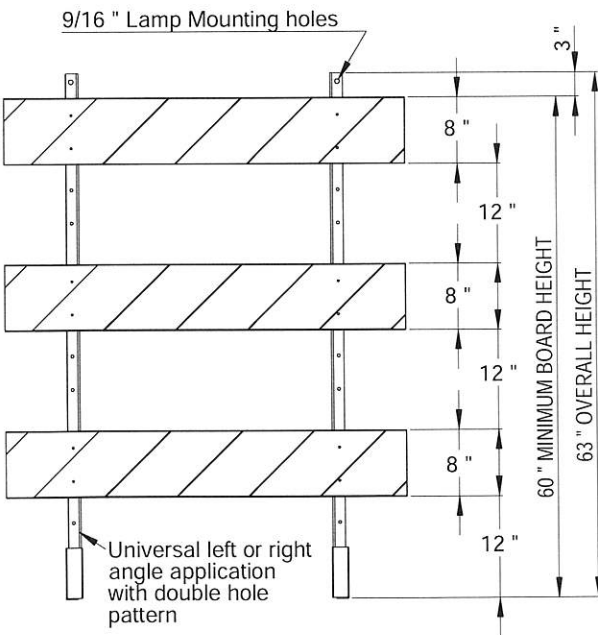

Telespar® & Angle Iron Barricades are sold in kits with three boards with your choice of sheeting. Sheeting can be on one side of the boards or both. All hardware needed for assembly is included in the kit.

PLASTICADE

7700 N. Austin Avenue
Skokie, IL 60077
phone (800) 772-0355
fax (847) 966-8074

www.plasticade.com

MADE IN THE USA

Diamond Panel



Lakeside Plastics Diamond Panel is a highly visible vertical traffic channelizer designed for service in a wide variety of vehicle and pedestrian applications.

The Diamond Panel features an easy-grip handle, allowing for easy carrying and quick positioning. The unique design and shape of the Diamond Panel allows convenient stacking/transport with or without the base. The Diamond Panel can be fitted with a barricade light or signage.



The Diamond Panel is made of high quality impact resistant polyethylene and can be ordered with reflective tapes and a variety of base weights (20#, 30#, 42#). Available in safety orange, lime green and white.



Diamond Panel Traffic Safety Channelizer

Material:

- High quality impact resistant polyethylene with reinforced handle
- MUTCD compliant

Available Colors:

- Safety Orange, Lime-Green or White with ultraviolet stabilizer for fade resistance

Physical Appearance

- Height 44" (1118 mm)
- Width 15" (381 mm) at base

Other Features

- Break-away design
- Stackable with or without base
- Easy-grip handle
- Mounting hole for warning light or sign
- Recessed area accepts a variety of tape and signage
- Choice of 100% recycled 20#, 30#, 42# rubber base

Note: Weights and measurements are approximate. Specifications are subject to change. Please contact Lakeside Plastics for current information.

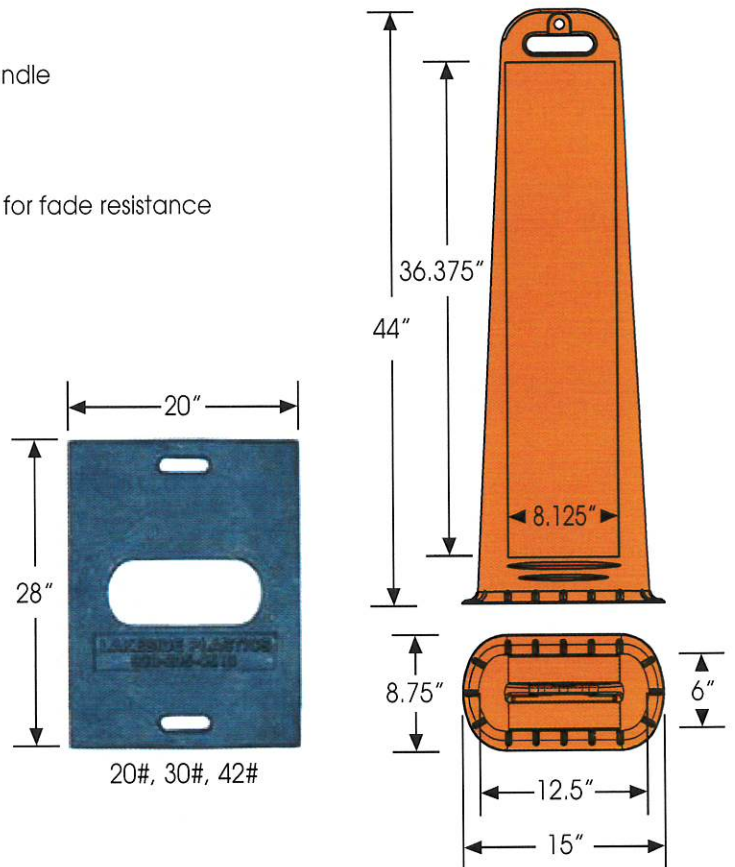

AC4D-NL

D-Cell LED Barricade Light



FACT SHEET



On/Off and Mode Switches

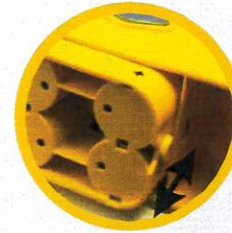

Battery Case Snaps In and Out



Battery Case w/Battery Direction Indicators

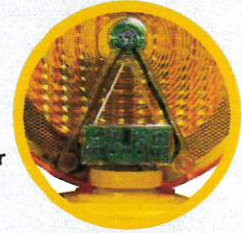

LED Mode/Sensor Circuitry



Hardware (Per Case of 10 Lights)



Expanded Color Selection

Features:

- Optically correct polycarbonate lens and high impact case.
- Exceeds ITE standards and MUTCD visibility specifications.
- Tested by a Coast Guard approved laboratory.
- Battery contacts made of corrosion resistant stainless steel.
- Lightweight, may be self-certified for compliance with NCHRP-350 crash test standards.
- Three modes of operation, Flash/Steady-Burn/Off.
- Each light supplied with mounting hardware: bolts, switch pins, and wrench. Cup washers available at extra cost.
- Will operate on 2 or 4 D-cell batteries.
- Standard package: 10 lights per carton.
- Weight per carton: 17 lbs.



#AC4D-NL	Yellow Case
#AC4D-OR-NL	Orange Case
#AC4D-BK-NL	Black Case
#AC4D-GR-NL	Green Case
#AC4D-BL-NL	Blue Case



DICKE SAFETY PRODUCTS

Illinois - 1201 Warren Avenue • Downers Grove, IL 60515 • Ph: 630.969.0050 • Fax: 630.969.3973

Oregon - 1845 Anunsen Street, N.E. • Salem, OR 97301 • Ph: 800.333.5641 • Fax: 503.364.0340

DIMENSIONS

A	28.00"
B	1.875"
C	1.25" DIAMETER
D	3.75"
E	6.5"
F	2.0"
G	4.5"
H	1.5"
I	.625"
J	14.75"
K	.14" WALL THICKNESS
L	.16" WALL THICKNESS
M	10.00"

CONE SIZE	BASE WEIGHT	TOTAL WEIGHT
28"		10.12 lbs

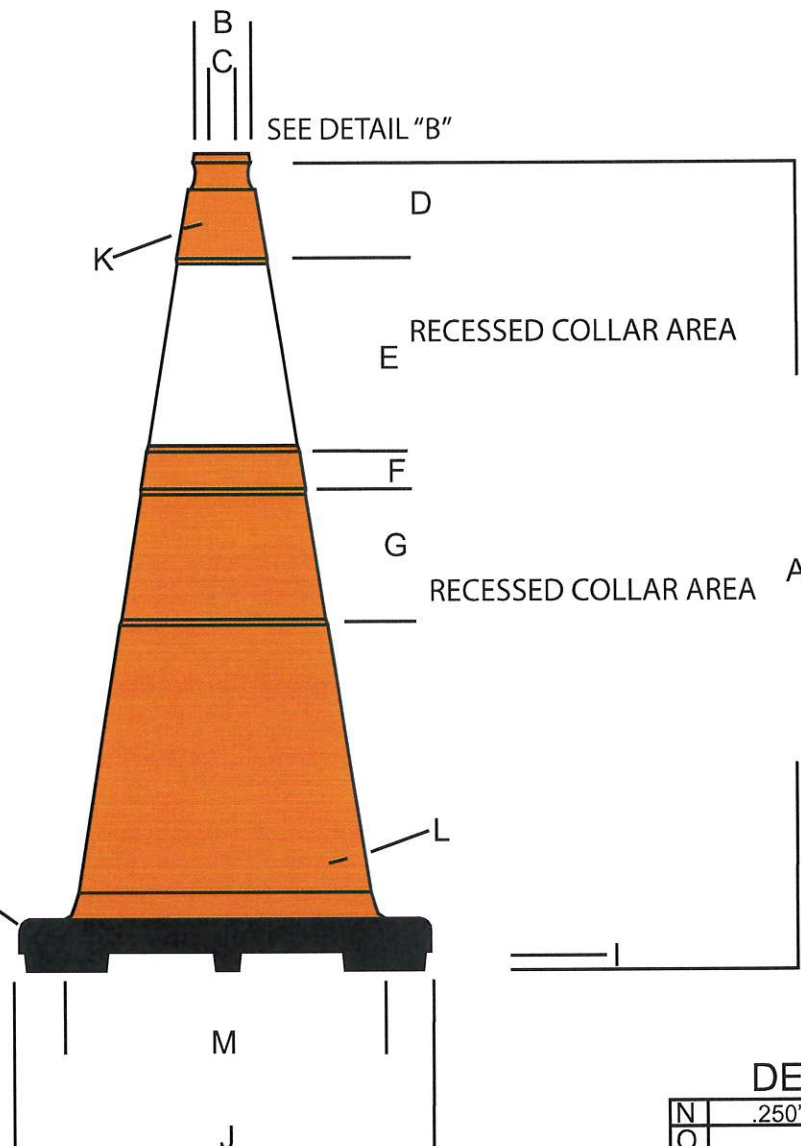

SEE DETAIL "A" BELOW

Notes:
 Conical section manufactured from 100% recyclable flourescent orange PVC
 Base manufactured form 100% post industrial recycled black PVC

DETAIL "B"

N	.250" RECESS
O	.3125"
P	.75"

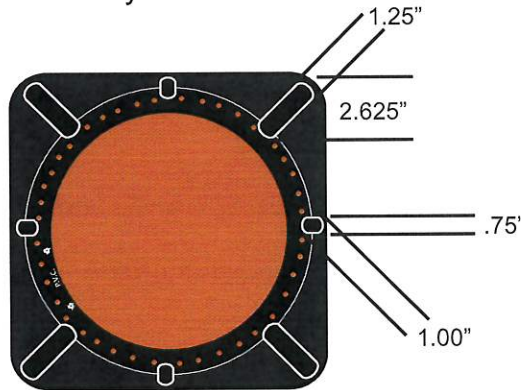
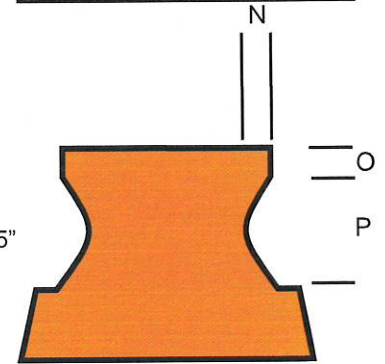

14.25"

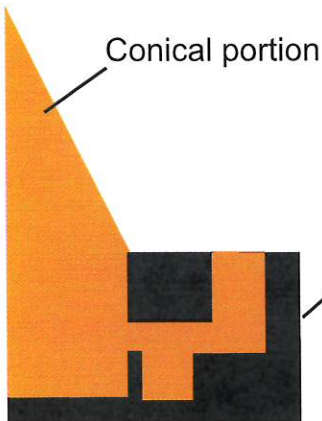

Circle Interlock System
 DETAIL "A"

 <p>working together</p>	<p>28" TRAFFIC CONE WIDE BODY RS70045CT+3M6</p>
	<p>JBC SAFETY PLASTIC INC. 710 NOGALES ST CITY OF INDUSTRY CA 91748 www.jbcsafety.com</p>
<p>Date 9/19/13</p>	<p>REVOLUTION SERIES</p>
<p>DWG. NO. RS70045CT3M6</p>	

DIMENSIONS

A	36.00"
B	1.875"
C	1.25" DIAMETER
D	3.75"
E	6.5"
F	2.0"
G	4.5"
H	1.5"
I	.625"
J	14.50"
K	.14" WALL THICKNESS
L	.16" WALL THICKNESS
M	10.00"

DETAIL "B"

N	.375" RECESS
O	.3125"
P	1.0"

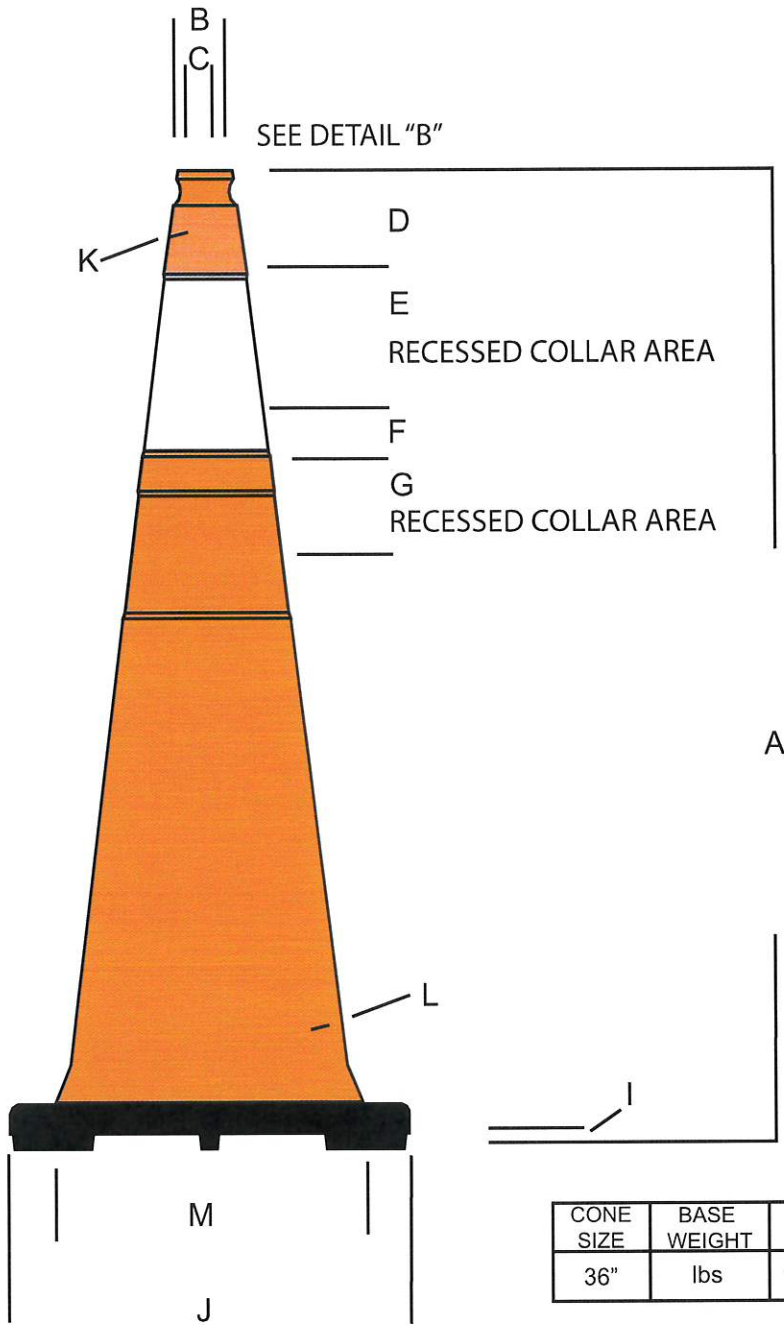
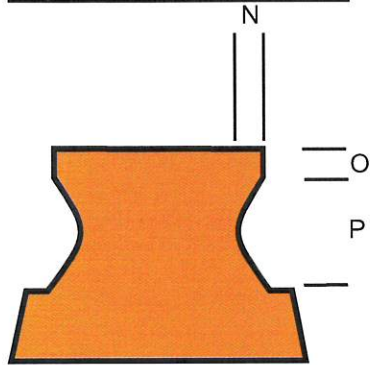

CONE SIZE	BASE WEIGHT	TOTAL WEIGHT
36"	lbs	10.12 lbs

Notes:

Conical section manufactured from 100% recyclable fluorescent orange PVC
 Base manufactured from 100% post industrial recycled black PVC

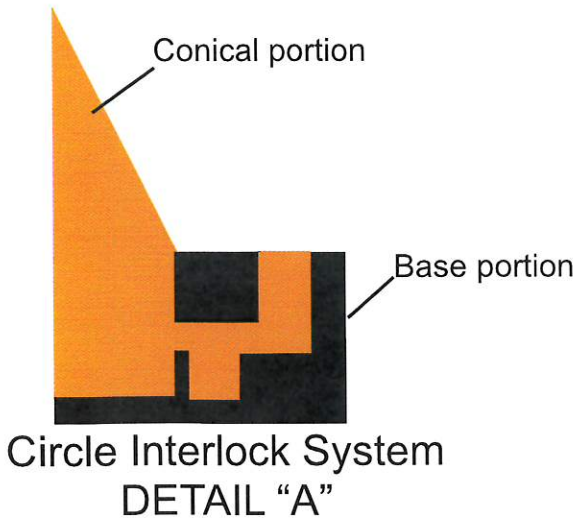

	<p>36" TRAFFIC CONE WIDE BODY RS90045CT+3M6</p>	
	<p>JBC SAFETY PLASTIC INC. 16750 CHESTNUT ST CITY OF INDUSTRY CA 91748 www.jbcsafety.com</p>	
<p>Date 5/30/13</p>	<p>REVOLUTION SERIES</p>	<p>DWG. NO. RS90045CT+3M6</p>



COUNTY PURCHASING AGENT
Fort Bend County, Texas

Vendor Information

Jaime Kovar
County Purchasing Agent

Office (281) 341-8640

Legal Company Name (top line of W9)	Vulcan, Inc.		
Business Name (if different from legal name)	DBA Vulcan Aluminum, Vulcan Signs		
Federal ID # or S.S. #	63-0513868	DUNS #	044496966
Type of Business	<input checked="" type="checkbox"/> Corporation/LLC <input type="checkbox"/> Sole Proprietor/Individual	<input type="checkbox"/> Partnership <input type="checkbox"/> Tax Exempt Organization	Age in Business? 54 years
Publicly Traded Business	<input checked="" type="checkbox"/> No <input type="checkbox"/> Yes Ticker Symbol _____		
Remittance Address	Dept # 6397 Vulcan Inc., P.O. Box 11407		
City/State/Zip	Birmingham, AL 35246-6397		
Physical Address	408 East Berry Avenue		
City/State/Zip	Foley, AL 36536		
Phone/Fax Number	Phone: 800-633-6845 Fax: 251-943-1544		
Contact Person	David B. Beviacqua		
E-mail	vulcan3@vulcaninc.com		
Check all that apply to the company listed above and provide certification number.	DBE-Disadvantaged Business Enterprise _____	Certification # _____	
	SBE-Small Business Enterprise _____	Certification # _____	
	HUB -Texas Historically Underutilized Business _____	Certification # _____	
	WBE-Women's Business Enterprise _____	Certification # _____	
Company's gross annual receipts	<\$500,000 _____	\$500,000-\$4,999,999 <input checked="" type="checkbox"/>	
	\$5,000,000-\$16,999,999 _____	\$17,000,000-\$22,399,999 _____	
	>\$22,400,000 _____		
NAICs codes (Please enter all that apply)	3313, 3312		
Signature of Authorized Representative			
Printed Name	David B. Beviacqua		
Title	General Manager		
Date	01/14/2021		

THIS FORM MUST BE SUBMITTED WITH THE SOLICITATION RESPONSE

*Fort Bend County, Texas
Invitation for Bid*



*Term Contract for the Purchase of Traffic Signs, Posts and Supplies
BID 21-048*

SUBMIT BIDS TO:

Fort Bend County
Purchasing Department
Travis Annex
301 Jackson, Suite 201
Richmond, TX 77469

Note: All correspondence must include the term "Purchasing Department" in address to assist in proper delivery.

SUBMIT NO LATER THAN:

Tuesday, January 19, 2021
2:00 PM (Central)

LABEL ENVELOPE:

BID 21-048
TRAFFIC SIGNS, POSTS, SUPPLIES

ALL BIDS MUST BE RECEIVED IN AND TIME/DATE STAMPED BY THE PURCHASING OFFICE OF FORT BEND COUNTY BEFORE THE SPECIFIED TIME/DATE STATED ABOVE.

BIDS RECEIVED AS REQUIRED WILL THEN BE OPENED AND PUBLICLY READ.

BIDS RECEIVED AFTER THE SPECIFIED TIME, WILL BE RETURNED UNOPENED.

Results will not be given by phone.
Results will be provided to bidder in writing after the Commissioners Court awards.

Requests for information must be in writing and directed to:
Cheryl Krejci, CPPB
Senior Buyer
cheryl.krejci@fortbendcountytexas.gov

Vendor Responsibilities:

- Download and complete any addendums. (Addendums will be posted on the Fort Bend County website no later than 48 hours prior to bid opening)
- Submit response in accordance with requirements stated on the cover of this document.
- DO NOT submit responses via email or fax.

1.0 GENERAL REQUIREMENTS:

- 1.1 Read this entire document carefully. Follow all instructions. You are responsible for fulfilling all requirements and specifications. Be sure you understand them.
- 1.2 General Requirements apply to all advertised bids, however, these may be superseded, whole or in part, by the scope, special requirements, specifications, special specifications or other data contained herein.
- 1.3 Governing Law: Bidder is advised that these requirements shall be fully governed by the laws of the State of Texas and that Fort Bend County may request and rely on advice, decisions and opinions of the Attorney General of Texas and the County Attorney concerning any portion of these requirements.
- 1.4 Bid Document Completion: Fill out, initial each page, sign, and return ONE (1) complete bid document to the Fort Bend County Purchasing Department. An authorized representative of the bidder must sign the Contract Sheet. Do not complete the date at the top of the contract sheet. The bid document must be in a sealed envelope marked with the appropriate bid number and title. The contract will be binding only when signed by the County Judge, Fort Bend County and a purchase order authorizing the item(s) desired has been issued. The use of correction fluid is not acceptable and may result in the disqualification of bid. If an error is made, the bidder must draw a line through error and initial each change. All response, typed or written, information must be clear and legible.

If a pricing form in Excel is included and posted on the County's website amongst this bid document, the Vendor must download, complete and save the Excel (not a PDF of the Excel file) file of the pricing form on a CD or flash drive. The Excel file on the CD or flash drive must be downloadable by the Purchasing Department in order to copy and paste the vendor's pricing to the County's tabulation. The CD or flash drive must be labeled and included in the same sealed envelope with the respondent's completed bid document along with a printed copy of the pricing form completed by the vendor.

- 1.5 Bid Returns: Bidders must return completed bid document to the Fort Bend County Purchasing Department at 301 Jackson, Suite 201, Richmond, Texas no later than 2:00 P.M. on the date specified. Late bids will not be accepted. Bids must be submitted in a sealed envelope, addressed as follows: Fort Bend County Purchasing Agent, Travis Annex, 301 Jackson, Suite 201, Richmond, Texas 77469.
- 1.6 Governing Document: In the event of any conflict between the terms and provisions of these requirements and the specifications, the specifications shall govern. In the event of any conflict of interpretation of any part of this overall document, Fort Bend County's interpretation shall govern.

Initials of Bidder: 

- 1.7 Addenda: No interpretation of the meaning of the drawings, specifications or other bid documents will be made to any bidder orally. All requests for such interpretations must be made in writing addressed to Ms. Cheryl Krejci, Senior Buyer, 301 Jackson, Suite 201, Richmond, Texas 77469, e-mail: cheryl.krejci@fortbendcountytexas.gov. Any and all interpretations and any supplemental instructions will be in the form of written addenda to the contract documents which will be posted on Fort Bend County's website. Addenda will **ONLY** be issued by the Fort Bend County Purchasing Agent. It is the sole responsibility of each bidder to insure receipt of any and all addenda. All addenda issued will become part of the contract documents. Bidders must sign and include addendum in the returned bid package. Deadline for submission of questions and/or clarification is **Tuesday, January 12, 2021 at 9:00 a.m. (CST)**. Requests received after the deadline will not be responded to due to the time constraints of this bid process.
- 1.8 Hold Harmless Agreement: Contractor shall indemnify and hold Fort Bend County harmless from all claims for personal injury, death and/or property damage arising from any cause whatsoever, resulting directly or indirectly from contractor's performance. Contractor shall procure and maintain, with respect to the subject matter of this bid, appropriate insurance coverage including, as a minimum, public liability and property damage with adequate limits to cover contractor's liability as may arise directly or indirectly from work performed under terms of this bid. Certification of such coverage must be provided to the County upon request.
- 1.9 Waiver of Subrogation: Bidder and bidder's insurance carrier waive any and all rights whatsoever with regard to subrogation against Fort Bend County as an indirect party to any suit arising out of personal or property damages resulting from bidder's performance under this agreement.
- 1.10 Severability: If any section, subsection, paragraph, sentence, clause, phrase or word of these requirements or the specifications shall be held invalid, such holding shall not affect the remaining portions of these requirements and the specifications and it is hereby declared that such remaining portions would have been included in these requirements and the specifications as though the invalid portion had been omitted.
- 1.11 Bonds: If this bid requires submission of bid guarantee and performance bond, there will be a separate page explaining those requirements. Bids submitted without the required bid bond or cashier's checks are not acceptable. Bond/s or cashier's check must be complete with all required signatures.
- 1.12 Taxes: Fort Bend County is exempt from all federal excise, state and local taxes unless otherwise stated in this document. Fort Bend County claims exemption from all sales and/or use taxes under Chapter 20, Title 122a, Vernon's Texas Civil Statutes, as amended. Texas Limited Sales Tax Exemption Certificates will be furnished upon written request to the Fort Bend County Purchasing Department.

Initials of Bidder: _____



- 1.13 Fiscal Funding: A multi-year lease or lease/purchase arrangement (if requested by the specifications), or any contract continuing as a result of an extension option, must include fiscal funding out. If, for any reason, funds are not appropriated to continue the lease or contract, said lease or contract shall become null and void. After expiration of the lease, leased equipment shall be removed by the bidder from the using department without penalty of any kind or form to Fort Bend County. All charges and physical activity related to delivery, installation, removal and redelivery shall be the responsibility of the bidder.
- 1.14 Pricing: Prices for all goods and/or services shall be firm for the duration of this contract and shall be stated in the bid spreadsheet. Prices shall be all inclusive. No price changes, additions, or subsequent qualifications will be honored during the course of the contract. All prices must be written in ink or typewritten. Pricing on all transportation, freight, and other charges are to be prepaid by the contractor and included in the bid prices. If there are any additional charges of any kind, other than those mentioned above, specified or unspecified, bidder MUST indicate the items required and attendant costs or forfeit the right to payment for such items.
- 1.15 Silence of Specifications: The apparent silence of specifications as to any detail, or the apparent omission from it of a detailed description concerning any point, shall be regarded as meaning that only the best commercial practice is to prevail and that only material and workmanship of the finest quality are to be used. All interpretations of specifications shall be made on the basis of this statement. The items furnished under this contract shall be new, unused of the latest product in production to commercial trade and shall be of the highest quality as to materials used and workmanship. Manufacturer furnishing these items shall be experienced in design and construction of such items and shall be an established supplier of the item bid.
- 1.16 Supplemental Materials: Bidders are responsible for including all pertinent product data in the returned bid package. Literature, brochures, data sheets, specification information, completed forms requested as part of the bid package and any other facts which may affect the evaluation and subsequent contract award should be included. Materials such as legal documents and contractual agreements, which the bidder wishes to include as a condition of the bid, must also be in the returned bid package. Failure to include all necessary and proper supplemental materials may be cause to reject the entire bid.
- 1.17 Material Safety Data Sheets: Under the "Hazardous Communication Act", commonly known as the "Texas Right To Know Act", a bidder must provide to County and using departments, with each delivery, material safety data sheets, which are, applicable to hazardous substances defined in the Act. Bidders are obligated to maintain a current, updated file in the Fort Bend County Purchasing Department. Failure of the bidder to maintain such a file will be cause to reject any bid applying thereto.

- 1.18 Name Brands: Specifications may reference name brands and model numbers. It is not the intent of Fort Bend County to restrict these bids in such cases, but to establish a desired quality level of merchandise or to meet a pre-established standard due to like existing items. Bidders may offer items of equal stature and the burden of proof of such stature rests with them. Fort Bend County shall act as sole judge in determining equality and acceptability of products offered.
- 1.19 Color Selection: Determination of colors of materials is a right reserved by the using department unless otherwise specified in the bid. Unspecified colors shall be quoted as standard colors, not colors, which require up charges or special handling. Unspecified fabrics or vinyl should be construed as medium grade. If bidder fails to get color/material approvals prior to delivery of merchandise, the using department may refuse to accept the items and demand correct shipment without penalty, subject to other legal remedies.
- 1.20 Evaluation: Evaluation shall be used as a determinant as to which bid items or services are the most efficient and/or most economical for the County. It shall be based on all factors, which have a bearing on price and performance of the items in the user environment. All bids are subject to tabulation by the Fort Bend County Purchasing Department and recommendation to Fort Bend County Commissioners Court. Compliance with all bid requirements, delivery and needs of the using department are considerations in evaluating bids. Pricing is NOT the only criteria for making a recommendation. The Fort Bend County Purchasing Department reserves the right to contact any bidder, at any time, to clarify, verify or request information with regard to any bid.
- 1.21 Inspections: Fort Bend County reserves the right to inspect any item(s) or service location for compliance with specifications and requirements and needs of the using department. If a bidder cannot furnish a sample of a bid item, where applicable, for review, or fails to satisfactorily show an ability to perform, the County can reject the bid as inadequate.
- 1.22 Testing: Fort Bend County reserves the right to test equipment, supplies, material and goods bid for quality, compliance with specifications and ability to meet the needs of the user. Demonstration units must be available for review. Should the goods or services fail to meet requirements and/or be unavailable for evaluation, the bid is subject to rejection.
- 1.23 Disqualification of Bidder: Upon signing this bid document, a bidder offering to sell supplies, materials, services, or equipment to Fort Bend County certifies that the bidder has not violated the antitrust laws of this state codified in section 15.01, et seq., Business & Commerce Code, or the federal antitrust laws, and has not communicated directly or indirectly the bid made to any competitor or any other person engaged in such line of business. Any or all bids may be rejected if the County believes that collusion exists among the bidders. Bids in which the prices are

Initials of Bidder:



- obviously unbalanced may be rejected. If multiple bids are submitted by a bidder and after the bids are opened, one of the bids is withdrawn, the result will be that all of the bids submitted by that bidder will be withdrawn; however, nothing herein prohibits a vendor from submitting multiple bids for different products or services.
- 1.24 Awards: Fort Bend County reserves the right to award this contract on the basis of lowest and best bid in accordance with the laws of the State of Texas, to waive any formality or irregularity, to make awards to more than one bidder, to reject any or all bids. In the event the lowest dollar bidder meeting specifications is not awarded a contract, the bidder may appear before the Commissioners Court and present evidence concerning his responsibility. An award is final only upon formal execution by the Fort Bend County Commissioners Court or the Fort Bend County Purchasing Agent. Fort Bend County reserves the right to withdraw any award until execution by the proper authority.
- 1.25 Assignment: The successful vendor may not assign, sell or otherwise transfer this contract without written permission of Fort Bend County Commissioners Court.
- 1.26 Term Contracts: If the contract is intended to cover a specific time period, said time will be given in the specifications under scope.
- 1.27 Maintenance: Maintenance required for equipment bid should be available in Fort Bend County by a manufacturer authorized maintenance facility. Costs for this service shall be shown on the bid sheet as requested or on a separate sheet, as required. If Fort Bend County opts to include maintenance, it shall be so stated in the purchase order and said cost will be included. Service will commence only upon expiration of applicable warranties and should be priced accordingly.
- 1.28 Contract Obligation: Fort Bend County Commissioners Court must award the contract and the County Judge or other person authorized by the Fort Bend County Commissioners Court must sign the contract before it becomes binding on Fort Bend County or the bidders. Department heads are not authorized to sign agreements for Fort Bend County. Binding agreements shall remain in effect until all products and/or services covered by this purchase have been satisfactorily delivered and accepted.
- 1.29 Title Transfer: Title and Risk of Loss of goods shall not pass to Fort Bend County until Fort Bend County actually receives and takes possession of the goods at the point or points of delivery. Receiving times may vary with the using department. Generally, deliveries may be made between 8:30 a.m. and 4:00 p.m., Monday through Friday. Bidders are advised to consult the using department for instructions. The place of delivery shall be shown under the "Special Requirement" section of this bid document and/or on the Purchase Order as a "Ship To:" address.
- 1.30 Purchase Order and Delivery: The successful bidder shall not deliver products or

Initials of Bidder: 

provide services without a Fort Bend County Purchase Order, signed by an authorized agent of the Fort Bend County Purchasing Department. The fastest, most reasonable delivery time shall be indicated by the bidder in the proper place on the bid sheet. Any special information concerning delivery should also be included, on a separate sheet, if necessary. All items shall be shipped F.O.B. inside delivery unless otherwise stated in the specifications. This shall be understood to include bringing merchandise to the appropriate room or place designated by the using department. Every tender or delivery of goods must fully comply with all provisions of these requirements and the specifications including time, delivery and quality. Nonconformance shall constitute a breach, which must be rectified prior to expiration of the time for performance. Failure to rectify within the performance period will be considered cause to reject future deliveries and cancellation of the contract by Fort Bend County without prejudice to other remedies provided by law. Where delivery times are critical, Fort Bend County reserves the right to award accordingly.

- 1.31 Contract Extension: Extensions may be made only by written agreement between Fort Bend County and the bidder. Any price escalations are limited to those stated by the bidder in the original bid.
- 1.32 Termination: Fort Bend County reserves the right to terminate the contract for default if Seller breaches any of the terms therein, including warranties of bidder or if the bidder becomes insolvent or commits acts of bankruptcy. Such right of termination is in addition to and not in lieu of any other remedies, which Fort Bend County may have in law or equity. Default may be construed as, but not limited to, failure to deliver the proper goods and/or services within the proper amount of time, and/or to properly perform any and all services required to Fort Bend County's satisfaction and/or to meet all other obligations and requirements. Contracts may be terminated without cause upon thirty (30) days written notice to either party unless otherwise specified.
- 1.33 Recycled Materials: Fort Bend County encourages the use of products made of recycled materials and shall give preference in purchasing to products made of recycled materials if the products meet applicable specifications as to quantity and quality. Fort Bend County will be the sole judge in determining product preference application.
- 1.34 Interlocal Participation: Additional governmental entities may purchase from this bid. Vendor agrees to accept purchase orders from those participating entities and to invoice each entity separately.
- 1.35 Escalation Clause: Successful bidder may apply for a price increase to the Fort Bend County Purchasing Agent. The County Purchasing Agent will review, and, if increase is deemed warranted, place the request on Fort Bend County's Commissioners Court agenda for their action of approval or disapproval. Approval by the County's Commissioner's Court is required. Any proposed price increase will

Initials of Bidder: 

only be the amount increased to the vendor from his/her supplier. The price increase request must be stated on the vendor's letterhead with the bid number and name in the subject including, in columns, for each item: item description, original bid price, percent of increase, and the total cost of the original bid price including the increased dollar amount. Written documentation from the vendor's supplier of the increase notice must be provided to the Purchasing Agent at time of increase request. No application for a price increase may be submitted within the first six (6) months of this contract. Increase requests of more than 25% of the original bid price will not be considered.

- 1.36 Modifications: This instrument contains the entire Contract between the parties relating to the rights herein granted and obligations herein assumed. Any oral or written representations or modifications concerning this instrument shall be of no force and effect excepting a subsequent written modification signed by both parties hereto.

2.0 TERMS & CONDITIONS:

- 2.1 Seller to Package Goods: Seller will package goods in accordance with good commercial practice. Each delivery container shall be clearly and permanently marked as follows (a) Seller's name and address; (b) Consignee's name, address and purchase order number and the bid number if applicable; (c) Container number and total number of containers (e.g. box 1 of 4 boxes); and (d) the number of the container bearing the packing slip. Seller shall bear cost of packaging unless otherwise provided. Goods shall be suitably packed to secure lowest transportation costs and to conform to requirements of common carriers and any applicable specifications. Fort Bend County's count or weight shall be final and conclusive on shipments not accompanied by packing list.
- 2.2 Shipment Under Reservation Prohibited: Seller is not authorized to ship goods under reservation and no tender of a bill of lading will operate as a tender of goods.
- 2.3 Title and Risk of Loss: The title and risk of loss of the goods shall not pass to the County until a County employee actually receives and takes possession of the goods at the point or points of delivery.
- 2.4 Delivery Terms: F.O.B. Destination Freight Prepaid, Inside Delivery, unless delivery terms are specified otherwise on Purchase Order.
- 2.5 No Replacement of Defective Tender: Every tender or delivery of goods must fully comply with all provisions of the Purchase Order as to time of delivery, quality and the like. If a tender is made which does not fully conform, this shall constitute a breach and Seller shall not have the right to substitute a conforming tender.
- 2.6 Place of Delivery: The place of delivery shall be that set forth in the block of the

Initials of Bidder: 

purchase order entitled "Ship To". Any change thereto shall be effective by modification as provided for in Clause number 2.20 "Modifications", hereof. The terms of this agreement are "no arrival, no sale", at the discretion of Fort Bend County.

2.7 Invoices and Payments:

2.7.1 Seller shall submit separate invoices, in duplicate. Invoices shall indicate the purchase order number and the bid number if applicable. Invoices shall be itemized and transportation charges, if any, shall be listed separately. A copy of the bill of lading, and the freight waybill when applicable should be attached to the invoice.

2.7.2 Fort Bend County's obligation is payable only and solely from funds available for the purpose of this purchase. Lack of funds shall render the order null and void to the extent funds are not available and any delivered but unpaid goods will be returned to Seller by the county.

2.7.3 Do not include Federal Excise, State, or City Sales Tax. Fort Bend County is a tax-exempt governmental entity.

2.8 Gratuities: Fort Bend County may, by written notice to the Seller, cancel any order without liability, if it is determined by the County that gratuities, in the form of entertainment, gifts, or otherwise were offered or given by the Seller, or any agent or representative of the Seller to any officer or employee of Fort Bend County with a view toward securing an order. In the event an order is canceled by the County pursuant to this provision, the County shall be entitled, in addition to any other rights and remedies, to recover or withhold the amount of the cost incurred by Seller in providing such gratuities.

2.9 Special Tools and Test Equipment: If the price stated on the face of an order includes the cost of any special tooling or special test equipment fabricated or required by Seller for the purpose of filing this order, such special tooling equipment and any process sheets related thereto shall become the property of the County and to the extent feasible shall be identified by the Seller as such.

2.10 Warranty/Price:

2.10.1 The price to be paid by the County shall be that contained in Seller's bid which Seller warrants to be no higher than Seller's current prices on orders by others for products of the kind and specification covered by an order for similar quantities under similar or like conditions and methods of purchase. In the event Seller breaches this warranty the prices of the items shall be reduced to the Seller's current prices on orders by others. Fort Bend County may cancel this contract without liability.

Initials of Bidder: 

- 2.10.2 The Seller warrants that no person or selling agency has been employed or retained to solicit or secure any County order based upon any agreement or understanding for commission, percentage, brokerage, or contingent fee excepting bona fide employees of bona fide established commercial or selling agencies maintained by the Seller for the purpose of securing business. A breach or violation of this warranty gives the County the right, in addition to any other right or rights, to cancel this contract without liability.
- 2.11 Warranty Product: Seller shall not limit or exclude any implied warranties and any attempt to do so shall render an order voidable at the option of the County. Seller warrants that the goods furnished will conform to the specifications, drawings, and description listed in the bid invitation and purchase order as applicable, and to the sample(s) furnished by Seller if any. In the event of a conflict between the specifications, drawings, and descriptions, the specifications shall govern.
- 2.12 Safety Warranty: Seller warrants that the product sold to Fort Bend County shall conform to the standards promulgated by the U.S. Department of Labor under the Occupational Safety and Health Act of 1970. In the event the product does not conform to OSHA standards, the County may return the product for correction or replacement at the Seller's expense. In the event Seller fails to make the appropriate correction within 10 days, correction made by the County will be at Seller's expense.
- 2.13 No Warranty by Fort Bend County Against Infringements: As part of a contract for sale Seller agrees to ascertain whether goods manufactured in accordance with the specifications will give rise to the rightful claim of any third person by way of infringement. Fort Bend County makes no warranty that the production of goods according to the specification will not give rise to such a claim and in no event shall Fort Bend County be liable to Seller for indemnification in the event the Seller is sued on the grounds of infringement or the like. If Seller is of the opinion that an infringement will result, he will notify Fort Bend County to this effect in writing within two days after the receiving Purchase Order. If the County does not receive notice and is subsequently held liable for the infringement, Seller will defend and save the County harmless. If Seller in good faith ascertains that production of the goods in accordance with the specifications will result in infringement, this contract shall be null and void except that the County will pay Seller the reasonable cost of his search as to infringements.
- 2.14 Right of Inspection: The County shall have the right to inspect the goods at delivery before accepting them.
- 2.15 Cancellation: Fort Bend County shall have the right to cancel for default all or any part of the undelivered portion of an order if Seller breaches any of the terms hereof including warranties of Seller, or if the Seller becomes insolvent or files for protection under the bankruptcy laws. Such rights of cancellation are in addition to and not in lieu of any other remedies, which Fort Bend County may have in law or

Initials of Bidder: 

equity.

- 2.16 Termination: The performance of work under a Purchase Order may be terminated in whole or in part by the County in accordance with this provision. Termination of work there under shall be effected by the delivery to the Seller of a "Notice of Termination" specifying the extent to which performance of work under the order is terminated and the date upon which such termination becomes effective. Such right of termination is in addition to and not in lieu of rights of Fort Bend County set forth in Clause 15 herein.
- 2.17 Force Majeure: Force Majeure means a delay encountered by a party in the performance of its obligations under this Agreement, which is caused by an event beyond the reasonable control of that party. Without limiting the generality of the foregoing, "Force Majeure" shall include but not be restricted to the following types of events: acts of God or public enemy; acts of governmental or regulatory authorities; fires, floods, epidemics or serious accidents; unusually severe weather conditions; strikes, lockouts, or other labor disputes; and defaults by subcontractors.
- In the event of a Force Majeure, the affected party shall not be deemed to have violated its obligations under this Agreement, and the time for performance of any obligations of that party shall be extended by a period of time necessary to overcome the effects of the Force Majeure, provided that the foregoing shall not prevent this Agreement from terminating in accordance with the termination provisions. If any event constituting a Force Majeure occurs, the affected party shall notify the other parties in writing, within twenty-four (24) hours, and disclose the estimated length of delay, and cause of the delay.
- 2.18 Assignment-Delegation: No right or interest in an order shall be assigned or delegation of any obligation made by Seller without the written permission of Fort Bend County. Any attempted assignment or delegation by Seller shall be wholly void and totally ineffective for all purposes unless made in conformity with this paragraph.
- 2.19 Waiver: No claim or right arising out of a breach of any contract can be discharged in whole or in part by a waiver or renunciation of the claim or right unless the waived or renunciation is supported by consideration and is in writing signed by the aggrieved party.
- 2.20 Modification: A Purchase Order can be modified or rescinded only by a writing signed by both of the parties or their duly authorized agents.
- 2.21 Parol Evidence: This writing is intended by the parties as a final expression of their agreement and is intended also as a complete and exclusive statement of the terms of this agreement. No course of prior dealings between the parties and no usage of the trade shall be relevant to supplement or explain any terms rendered under this agreement and shall not be relevant to determine the meaning of this agreement even

Initials of Bidder: 

though the accepting or acquiescing party has knowledge of the performance and opportunity for objection. Whenever a term defined by the Uniform Commercial Code is used in this agreement, the definition contained in the Code is to control.

- 2.22 **Applicable Law:** This agreement shall be governed by the Uniform Commercial Code. Whenever the term "Uniform Commercial Code" is used it shall be construed as meaning the Uniform Commercial Code as adopted in the State of Texas and in effect on the date of the purchase order.
- 2.23 **Advertising:** Seller shall not advertise or publish, without the County's prior consent the fact that Fort Bend County has entered into any contract, except to the extent necessary to comply with proper requests for information from an authorized representative of the federal, state, or local government.
- 2.24 **Right to Assurance:** Whenever the County in good faith has reason to question the other party's intent to perform. The County may demand that the other party give written assurance of his intent to perform. In the event that a demand is made and no assurance is given within five (5) days, the County may treat this failure as an anticipatory repudiation of the contract.
- 2.25 **Venue:** Both parties agree that venue for any litigation arising from this contract shall lie in Richmond, Fort Bend County, Texas.
- 2.26 **Prohibition Against Personal Interest in Contracts:** No officer or employee of the County shall have a financial interest, direct or indirect, in any contract with the County, or shall be financially interested, directly or indirectly, in the sale to the County of any land, materials, supplies, or service, except on behalf of the County as an officer or employee. Any willful violation of this section shall constitute malfeasance in office, and any officer or employee guilty thereof shall be subject to disciplinary action under applicable laws, statutes and codes of the State of Texas. Any violation of this section, with the knowledge, expressed or implied of the person or corporation contracting with the County shall render the contract involved voidable by the County Commissioners Court.

3.0 SCOPE:

It is the intent of Fort Bend County to contract with one (1) or more vendors to provide traffic signs, posts and supplies for Fort Bend County as specified herein.

4.0 TERM OF CONTRACT:

The term of this contract is **April 1, 2021 through March 31, 2022**, renewable annually for four (4) years (through 31 March 2026) under the same terms and conditions if mutually agreeable by both parties. Either party for any reason may terminate this contract by giving thirty (30) days written notice of the intent to terminate.

Initials of Bidder: RB

5.0 TEXAS ETHICS COMMISSION FORM 1295:

- 5.1 Effective January 1, 2016 all contracts executed by Commissioners Court, regardless of the dollar amount, will require completion of Form 1295 "Certificate of Interested Parties", per the new Government Code Statute §2252.908. All vendors submitting a response to a formal Bid, RFP, SOQ or any contracts, contract amendments, renewals or change orders are required to complete the Form 1295 online through the State of Texas Ethics Commission website. Please visit: https://www.ethics.state.tx.us/whatsnew/elf_info_form1295.htm.
- 5.2 On-line instructions:
 - 5.2.1 Name of governmental entity is to read: Fort Bend County.
 - 5.2.2 Identification number used by the governmental entity is: B21-048.
 - 5.2.3 Description is the title of the solicitation: Traffic Signs, Posts, Supplies.
- 5.3 Apparent low bidder(s) will be required to provide the Form 1295 within three (3) calendar days from notification; however, if your company is publicly traded you are not required to complete this form.

6.0 STATE LAW REQUIREMENTS FOR CONTRACTS:

The contents of this section are required by Texas Law and are included by County regardless of content.

- 6.1 Agreement to Not Boycott Israel Chapter 2270 Texas Government Code: By signature on vendor form, Contractor verifies Contractor does not boycott Israel and will not boycott Israel during the term of this Contract.
- 6.2 Texas Government Code Section 2251.152 Acknowledgment: By signature on vendor form, Contractor represents pursuant to Section 2252.152 of the Texas Government Code, that Contractor is not listed on the website of the Comptroller of the State of Texas concerning the listing of companies that are identified under Section 806.051, Section 807.051 or Section 2253.153.

7.0 HUMAN TRAFFICKING:

By acceptance of this contract, Contractor acknowledges that Fort Bend County is opposed to human trafficking and that no County funds will be used in support of services or activities that violate human trafficking laws.

Initials of Bidder: _____



8.0 ASSIGNMENT:

Contractor shall not sell, assign, transfer or convey these services, in whole or in part, without the prior written consent of Fort Bend County and as a condition of such consent, contractor shall remain liable for completion of the services in the event of default by the successor contractor or assignee.

9.0 AWARD:

This contract will be awarded to the lowest and best bidder per section.

10.0 GENERAL:

- 10.1 Quantities listed are estimates only. Fort Bend County does not guarantee the quantities stated will be purchased.
- 10.2 No minimum orders, by quantity or dollar amount.
- 10.3 Bidders may be required to submit samples for inspection and evaluation after bid opening to determine acceptability.

11.0 DELIVERY:

- 11.1 Vendor must complete delivery within thirty (30) working days after receipt of purchase order.
- 11.2 The successful bidder shall not deliver products without a Purchase Order issued by the Fort Bend County Purchasing Agent.
- 11.3 The successful bidder shall not deliver products or services in excess of those authorized and under no circumstances will Fort Bend County be liable for payment of products or services, which exceed the amounts authorized by the purchase order.
- 11.4 All orders must be delivered between 8:00 AM and 3:00 PM, Monday through Friday to the address indicated on purchase order.

12.0 SPECIFICATIONS and BID PRICING:

Specifications are located in the Excel pricing form downloadable from Fort Bend County's website. Provide bid prices in the electronic Excel file and return as stated in Section 1.4 and 1.5.

13.0 QUALITY CONTROL:

Fort Bend County reserves the right to sample and test products at time of delivery for specification compliance in the presence of the driver or vendor's representative. Costs for tests shall be borne by the Contractor in the event product fails to meet specifications. Products not in their original

Initials of Bidder:



package will not be accepted.

14.0 REQUIRED FORMS:

All vendors submitting are required to complete and provide with submission:

- 14.1 Electronic Excel file of Pricing Form on CD or flash drive and printed hard copy
- 14.2 Vendor Form
- 14.3 W9 Form
- 14.4 Tax Form/Debt/Residence Certification

Initials of Bidder: DB

Contract Sheet
Bid 21-048

THE STATE OF TEXAS
COUNTY OF FORT BEND

This memorandum of agreement made and entered into on the 23rd day of March, 2021,
by and between Fort Bend County in the State of Texas (hereinafter designated County), acting herein by
County Judge KP George, by virtue of an order of Fort Bend County Commissioners Court, and
Vulcan Inc, DBA Vulcan Aluminum, Vulcan Signs (hereinafter designated Contractor).
(company name)

WITNESSETH:

The Contractor and the County agree that the bid and specifications for the **Purchase of Traffic Signs, Posts and Supplies** which are hereto attached and made a part hereof, together with this instrument and the bond (when required) shall constitute the full agreement and contract between parties and for furnishing the items set out and described; the County agrees to pay the prices stipulated in the accepted bid.

It is further agreed that this contract shall not become binding or effective until signed by the parties hereto and a purchase order authorizing the items desired has been issued.

Executed at Richmond, Texas this 23 day of March 2021.

By: County Judge KP George
Fort Bend County, Texas
County Judge, KP George

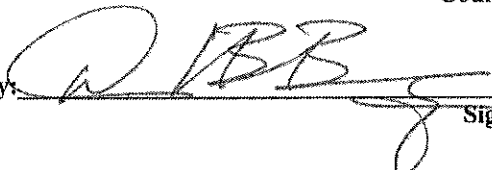
By: Signature of Contractor
David B. Beviacqua, General Manager
Printed Name and Title



COUNTY PURCHASING AGENT
Fort Bend County, Texas

Jaime Kovar
County Purchasing Agent

(281) 341-8640
Fax (281) 341-8645

January 4, 2021

TO: All Prospective Bidders

RE: Addendum No. 1 – Fort Bend County Bid 21-048 – Traffic Signs, Posts & Supplies

Addendum 1:

Attached is addendum 1. Vendors are to use Addendum 1 document while preparing their solicitation response. Contract name updated on Contract Sheet, page 17.

Immediately upon your receipt of this addendum, please fill out the following information and email this page to Jessica Carabajal at jessica.carabajal@fortbendcountytexas.gov

Vulcan Inc. DBA Vulcan Aluminum, Vulcan Signs

Company Name

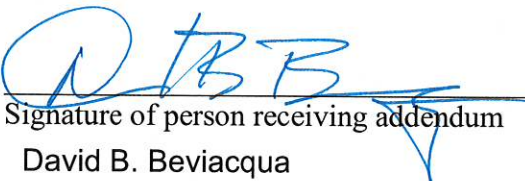

Signature of person receiving addendum
Date

01-14-2021

If you have any questions, please contact this office.

Sincerely,

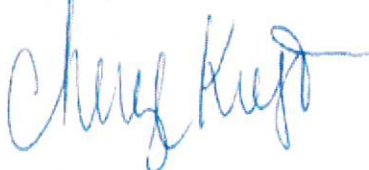

Cheryl Krejci
Senior Buyer

Request for Taxpayer Identification Number and Certification

**Give Form to the
 requester. Do not
 send to the IRS.**

Print or type
 See Specific Instructions on page 2.

	1 Name (as shown on your income tax return). Name is required on this line; do not leave this line blank. Vulcan, Inc.	
	2 Business name/disregarded entity name, if different from above 63-0513868	
	3 Check appropriate box for federal tax classification; check only one of the following seven boxes: <input type="checkbox"/> Individual/sole proprietor or single-member LLC <input type="checkbox"/> Limited liability company. Enter the tax classification (C=C corporation, S=S corporation, P=partnership) ▶ _____ <input type="checkbox"/> C Corporation <input checked="" type="checkbox"/> S Corporation <input type="checkbox"/> Partnership <input type="checkbox"/> Trust/estate Note. For a single-member LLC that is disregarded, do not check LLC; check the appropriate box in the line above for the tax classification of the single-member owner. <input type="checkbox"/> Other (see instructions) ▶ _____	4 Exemptions (codes apply only to certain entities, not individuals; see instructions on page 3): Exempt payee code (if any) _____ Exemption from FATCA reporting code (if any) _____ <i>(Applies to accounts maintained outside the U.S.)</i>
	5 Address (number, street, and apt. or suite no.) Vulcan Inc. DBA Vulcan Aluminum, Vulcan Signs	Requester's name and address (optional)
	6 City, state, and ZIP code P.O. Box 1850 Foley, AL 36536-1850	
	7 List account number(s) here (optional)	

Part I Taxpayer Identification Number (TIN)

Enter your TIN in the appropriate box. The TIN provided must match the name given on line 1 to avoid backup withholding. For individuals, this is generally your social security number (SSN). However, for a resident alien, sole proprietor, or disregarded entity, see the Part I instructions on page 3. For other entities, it is your employer identification number (EIN). If you do not have a number, see *How to get a TIN* on page 3.

Note. If the account is in more than one name, see the instructions for line 1 and the chart on page 4 for guidelines on whose number to enter.

Social security number	
[] [] [] - [] [] - [] [] [] []	
or	
Employer identification number	
6 3 - 0 5 1 3 8 6 8	

Part II Certification

- Under penalties of perjury, I certify that:
- The number shown on this form is my correct taxpayer identification number (or I am waiting for a number to be issued to me); and
 - I am not subject to backup withholding because: (a) I am exempt from backup withholding, or (b) I have not been notified by the Internal Revenue Service (IRS) that I am subject to backup withholding as a result of a failure to report all interest or dividends, or (c) the IRS has notified me that I am no longer subject to backup withholding; and
 - I am a U.S. citizen or other U.S. person (defined below); and
 - The FATCA code(s) entered on this form (if any) indicating that I am exempt from FATCA reporting is correct.

Certification instructions. You must cross out item 2 above if you have been notified by the IRS that you are currently subject to backup withholding because you have failed to report all interest and dividends on your tax return. For real estate transactions, item 2 does not apply. For mortgage interest paid, acquisition or abandonment of secured property, cancellation of debt, contributions to an individual retirement arrangement (IRA), and generally, payments other than interest and dividends, you are not required to sign the certification, but you must provide your correct TIN. See the instructions on page 3.

Sign Here	Signature of U.S. person ▶	Date ▶ 01/14/2021
------------------	----------------------------	-------------------

General Instructions

Section references are to the Internal Revenue Code unless otherwise noted.

Future developments. Information about developments affecting Form W-9 (such as legislation enacted after we release it) is at www.irs.gov/fw9.

Purpose of Form

An individual or entity (Form W-9 requester) who is required to file an information return with the IRS must obtain your correct taxpayer identification number (TIN) which may be your social security number (SSN), individual taxpayer identification number (ITIN), adoption taxpayer identification number (ATIN), or employer identification number (EIN), to report on an information return the amount paid to you, or other amount reportable on an information return. Examples of information returns include, but are not limited to, the following:

- Form 1099-INT (interest earned or paid)
- Form 1099-DIV (dividends, including those from stocks or mutual funds)
- Form 1099-MISC (various types of income, prizes, awards, or gross proceeds)
- Form 1099-B (stock or mutual fund sales and certain other transactions by brokers)
- Form 1099-S (proceeds from real estate transactions)
- Form 1099-K (merchant card and third party network transactions)

- Form 1098 (home mortgage interest), 1098-E (student loan interest), 1098-T (tuition)
 - Form 1099-C (canceled debt)
 - Form 1099-A (acquisition or abandonment of secured property)
- Use Form W-9 only if you are a U.S. person (including a resident alien), to provide your correct TIN.
- If you do not return Form W-9 to the requester with a TIN, you might be subject to backup withholding. See What is backup withholding? on page 2.*
- By signing the filled-out form, you:
- Certify that the TIN you are giving is correct (or you are waiting for a number to be issued),
 - Certify that you are not subject to backup withholding, or
 - Claim exemption from backup withholding if you are a U.S. exempt payee. If applicable, you are also certifying that as a U.S. person, your allocable share of any partnership income from a U.S. trade or business is not subject to the withholding tax on foreign partners' share of effectively connected income, and
 - Certify that FATCA code(s) entered on this form (if any) indicating that you are exempt from the FATCA reporting, is correct. See *What is FATCA reporting?* on page 2 for further information.

Note. If you are a U.S. person and a requester gives you a form other than Form W-9 to request your TIN, you must use the requester's form if it is substantially similar to this Form W-9.

Definition of a U.S. person. For federal tax purposes, you are considered a U.S. person if you are:

- An individual who is a U.S. citizen or U.S. resident alien;
- A partnership, corporation, company, or association created or organized in the United States or under the laws of the United States;
- An estate (other than a foreign estate); or
- A domestic trust (as defined in Regulations section 301.7701-7).

Special rules for partnerships. Partnerships that conduct a trade or business in the United States are generally required to pay a withholding tax under section 1446 on any foreign partners' share of effectively connected taxable income from such business. Further, in certain cases where a Form W-9 has not been received, the rules under section 1446 require a partnership to presume that a partner is a foreign person, and pay the section 1446 withholding tax. Therefore, if you are a U.S. person that is a partner in a partnership conducting a trade or business in the United States, provide Form W-9 to the partnership to establish your U.S. status and avoid section 1446 withholding on your share of partnership income.

In the cases below, the following person must give Form W-9 to the partnership for purposes of establishing its U.S. status and avoiding withholding on its allocable share of net income from the partnership conducting a trade or business in the United States:

- In the case of a disregarded entity with a U.S. owner, the U.S. owner of the disregarded entity and not the entity;
- In the case of a grantor trust with a U.S. grantor or other U.S. owner, generally, the U.S. grantor or other U.S. owner of the grantor trust and not the trust; and
- In the case of a U.S. trust (other than a grantor trust), the U.S. trust (other than a grantor trust) and not the beneficiaries of the trust.

Foreign person. If you are a foreign person or the U.S. branch of a foreign bank that has elected to be treated as a U.S. person, do not use Form W-9. Instead, use the appropriate Form W-8 or Form 8233 (see Publication 515, Withholding of Tax on Nonresident Aliens and Foreign Entities).

Nonresident alien who becomes a resident alien. Generally, only a nonresident alien individual may use the terms of a tax treaty to reduce or eliminate U.S. tax on certain types of income. However, most tax treaties contain a provision known as a "saving clause." Exceptions specified in the saving clause may permit an exemption from tax to continue for certain types of income even after the payee has otherwise become a U.S. resident alien for tax purposes.

If you are a U.S. resident alien who is relying on an exception contained in the saving clause of a tax treaty to claim an exemption from U.S. tax on certain types of income, you must attach a statement to Form W-9 that specifies the following five items:

1. The treaty country. Generally, this must be the same treaty under which you claimed exemption from tax as a nonresident alien.
2. The treaty article addressing the income.
3. The article number (or location) in the tax treaty that contains the saving clause and its exceptions.
4. The type and amount of income that qualifies for the exemption from tax.
5. Sufficient facts to justify the exemption from tax under the terms of the treaty article.

Example. Article 20 of the U.S.-China income tax treaty allows an exemption from tax for scholarship income received by a Chinese student temporarily present in the United States. Under U.S. law, this student will become a resident alien for tax purposes if his or her stay in the United States exceeds 5 calendar years. However, paragraph 2 of the first Protocol to the U.S.-China treaty (dated April 30, 1984) allows the provisions of Article 20 to continue to apply even after the Chinese student becomes a resident alien of the United States. A Chinese student who qualifies for this exception (under paragraph 2 of the first protocol) and is relying on this exception to claim an exemption from tax on his or her scholarship or fellowship income would attach to Form W-9 a statement that includes the information described above to support that exemption.

If you are a nonresident alien or a foreign entity, give the requester the appropriate completed Form W-8 or Form 8233.

Backup Withholding

What is backup withholding? Persons making certain payments to you must under certain conditions withhold and pay to the IRS 28% of such payments. This is called "backup withholding." Payments that may be subject to backup withholding include interest, tax-exempt interest, dividends, broker and barter exchange transactions, rents, royalties, nonemployee pay, payments made in settlement of payment card and third party network transactions, and certain payments from fishing boat operators. Real estate transactions are not subject to backup withholding.

You will not be subject to backup withholding on payments you receive if you give the requester your correct TIN, make the proper certifications, and report all your taxable interest and dividends on your tax return.

Payments you receive will be subject to backup withholding if:

1. You do not furnish your TIN to the requester,
2. You do not certify your TIN when required (see the Part II instructions on page 3 for details),

3. The IRS tells the requester that you furnished an incorrect TIN,

4. The IRS tells you that you are subject to backup withholding because you did not report all your interest and dividends on your tax return (for reportable interest and dividends only), or

5. You do not certify to the requester that you are not subject to backup withholding under 4 above (for reportable interest and dividend accounts opened after 1983 only).

Certain payees and payments are exempt from backup withholding. See *Exempt payee code* on page 3 and the separate Instructions for the Requester of Form W-9 for more information.

Also see *Special rules for partnerships* above.

What is FATCA reporting?

The Foreign Account Tax Compliance Act (FATCA) requires a participating foreign financial institution to report all United States account holders that are specified United States persons. Certain payees are exempt from FATCA reporting. See *Exemption from FATCA reporting code* on page 3 and the Instructions for the Requester of Form W-9 for more information.

Updating Your Information

You must provide updated information to any person to whom you claimed to be an exempt payee if you are no longer an exempt payee and anticipate receiving reportable payments in the future from this person. For example, you may need to provide updated information if you are a C corporation that elects to be an S corporation, or if you no longer are tax exempt. In addition, you must furnish a new Form W-9 if the name or TIN changes for the account; for example, if the grantor of a grantor trust dies.

Penalties

Failure to furnish TIN. If you fail to furnish your correct TIN to a requester, you are subject to a penalty of \$50 for each such failure unless your failure is due to reasonable cause and not to willful neglect.

Civil penalty for false information with respect to withholding. If you make a false statement with no reasonable basis that results in no backup withholding, you are subject to a \$500 penalty.

Criminal penalty for falsifying information. Willfully falsifying certifications or affirmations may subject you to criminal penalties including fines and/or imprisonment.

Misuse of TINs. If the requester discloses or uses TINs in violation of federal law, the requester may be subject to civil and criminal penalties.

Specific Instructions

Line 1

You must enter one of the following on this line; **do not** leave this line blank. The name should match the name on your tax return.

If this Form W-9 is for a joint account, list first, and then circle, the name of the person or entity whose number you entered in Part I of Form W-9.

a. **Individual.** Generally, enter the name shown on your tax return. If you have changed your last name without informing the Social Security Administration (SSA) of the name change, enter your first name, the last name as shown on your social security card, and your new last name.

Note. ITIN applicant: Enter your individual name as it was entered on your Form W-7 application, line 1a. This should also be the same as the name you entered on the Form 1040/1040A/1040EZ you filed with your application.

b. **Sole proprietor or single-member LLC.** Enter your individual name as shown on your 1040/1040A/1040EZ on line 1. You may enter your business, trade, or "doing business as" (DBA) name on line 2.

c. **Partnership, LLC that is not a single-member LLC, C Corporation, or S Corporation.** Enter the entity's name as shown on the entity's tax return on line 1 and any business, trade, or DBA name on line 2.

d. **Other entities.** Enter your name as shown on required U.S. federal tax documents on line 1. This name should match the name shown on the charter or other legal document creating the entity. You may enter any business, trade, or DBA name on line 2.

e. **Disregarded entity.** For U.S. federal tax purposes, an entity that is disregarded as an entity separate from its owner is treated as a "disregarded entity." See Regulations section 301.7701-2(c)(2)(iii). Enter the owner's name on line 1. The name of the entity entered on line 1 should never be a disregarded entity. The name on line 1 should be the name shown on the income tax return on which the income should be reported. For example, if a foreign LLC that is treated as a disregarded entity for U.S. federal tax purposes has a single owner that is a U.S. person, the U.S. owner's name is required to be provided on line 1. If the direct owner of the entity is also a disregarded entity, enter the first owner that is not disregarded for federal tax purposes. Enter the disregarded entity's name on line 2, "Business name/disregarded entity name." If the owner of the disregarded entity is a foreign person, the owner must complete an appropriate Form W-8 instead of a Form W-9. This is the case even if the foreign person has a U.S. TIN.

Line 2

If you have a business name, trade name, DBA name, or disregarded entity name, you may enter it on line 2.

Line 3

Check the appropriate box in line 3 for the U.S. federal tax classification of the person whose name is entered on line 1. Check only one box in line 3.

Limited Liability Company (LLC). If the name on line 1 is an LLC treated as a partnership for U.S. federal tax purposes, check the "Limited Liability Company" box and enter "P" in the space provided. If the LLC has filed Form 8832 or 2553 to be taxed as a corporation, check the "Limited Liability Company" box and in the space provided enter "C" for C corporation or "S" for S corporation. If it is a single-member LLC that is a disregarded entity, do not check the "Limited Liability Company" box; instead check the first box in line 3 "Individual/sole proprietor or single-member LLC."

Line 4, Exemptions

If you are exempt from backup withholding and/or FATCA reporting, enter in the appropriate space in line 4 any code(s) that may apply to you.

Exempt payee code.

- Generally, individuals (including sole proprietors) are not exempt from backup withholding.
- Except as provided below, corporations are exempt from backup withholding for certain payments, including interest and dividends.
- Corporations are not exempt from backup withholding for payments made in settlement of payment card or third party network transactions.
- Corporations are not exempt from backup withholding with respect to attorneys' fees or gross proceeds paid to attorneys, and corporations that provide medical or health care services are not exempt with respect to payments reportable on Form 1099-MISC.

The following codes identify payees that are exempt from backup withholding. Enter the appropriate code in the space in line 4.

- 1—An organization exempt from tax under section 501(a), any IRA, or a custodial account under section 403(b)(7) if the account satisfies the requirements of section 401(f)(2)
- 2—The United States or any of its agencies or instrumentalities
- 3—A state, the District of Columbia, a U.S. commonwealth or possession, or any of their political subdivisions or instrumentalities
- 4—A foreign government or any of its political subdivisions, agencies, or instrumentalities
- 5—A corporation
- 6—A dealer in securities or commodities required to register in the United States, the District of Columbia, or a U.S. commonwealth or possession
- 7—A futures commission merchant registered with the Commodity Futures Trading Commission
- 8—A real estate investment trust
- 9—An entity registered at all times during the tax year under the Investment Company Act of 1940
- 10—A common trust fund operated by a bank under section 584(a)
- 11—A financial institution
- 12—A middleman known in the investment community as a nominee or custodian
- 13—A trust exempt from tax under section 664 or described in section 4947

The following chart shows types of payments that may be exempt from backup withholding. The chart applies to the exempt payees listed above, 1 through 13.

IF the payment is for . . .	THEN the payment is exempt for . . .
Interest and dividend payments	All exempt payees except for 7
Broker transactions	Exempt payees 1 through 4 and 6 through 11 and all C corporations. S corporations must not enter an exempt payee code because they are exempt only for sales of noncovered securities acquired prior to 2012.
Barter exchange transactions and patronage dividends	Exempt payees 1 through 4
Payments over \$600 required to be reported and direct sales over \$5,000 ¹	Generally, exempt payees 1 through 5 ²
Payments made in settlement of payment card or third party network transactions	Exempt payees 1 through 4

¹ See Form 1099-MISC, Miscellaneous Income, and its instructions.

² However, the following payments made to a corporation and reportable on Form 1099-MISC are not exempt from backup withholding: medical and health care payments, attorneys' fees, gross proceeds paid to an attorney reportable under section 6045(f), and payments for services paid by a federal executive agency.

Exemption from FATCA reporting code. The following codes identify payees that are exempt from reporting under FATCA. These codes apply to persons submitting this form for accounts maintained outside of the United States by certain foreign financial institutions. Therefore, if you are only submitting this form for an account you hold in the United States, you may leave this field blank. Consult with the person requesting this form if you are uncertain if the financial institution is subject to these requirements. A requester may indicate that a code is not required by providing you with a Form W-9 with "Not Applicable" (or any similar indication) written or printed on the line for a FATCA exemption code.

- A—An organization exempt from tax under section 501(a) or any individual retirement plan as defined in section 7701(a)(37)
- B—The United States or any of its agencies or instrumentalities
- C—A state, the District of Columbia, a U.S. commonwealth or possession, or any of their political subdivisions or instrumentalities
- D—A corporation the stock of which is regularly traded on one or more established securities markets, as described in Regulations section 1.1472-1(c)(1)(i)
- E—A corporation that is a member of the same expanded affiliated group as a corporation described in Regulations section 1.1472-1(c)(1)(i)
- F—A dealer in securities, commodities, or derivative financial instruments (including notional principal contracts, futures, forwards, and options) that is registered as such under the laws of the United States or any state
- G—A real estate investment trust
- H—A regulated investment company as defined in section 851 or an entity registered at all times during the tax year under the Investment Company Act of 1940
 - I—A common trust fund as defined in section 584(a)
 - J—A bank as defined in section 581
 - K—A broker
 - L—A trust exempt from tax under section 664 or described in section 4947(a)(1)
 - M—A tax exempt trust under a section 403(b) plan or section 457(g) plan

Note. You may wish to consult with the financial institution requesting this form to determine whether the FATCA code and/or exempt payee code should be completed.

Line 5

Enter your address (number, street, and apartment or suite number). This is where the requester of this Form W-9 will mail your information returns.

Line 6

Enter your city, state, and ZIP code.

Part I. Taxpayer Identification Number (TIN)

Enter your TIN in the appropriate box. If you are a resident alien and you do not have and are not eligible to get an SSN, your TIN is your IRS individual taxpayer identification number (ITIN). Enter it in the social security number box. If you do not have an ITIN, see *How to get a TIN* below.

If you are a sole proprietor and you have an EIN, you may enter either your SSN or EIN. However, the IRS prefers that you use your SSN.

If you are a single-member LLC that is disregarded as an entity separate from its owner (see *Limited Liability Company (LLC)* on this page), enter the owner's SSN (or EIN, if the owner has one). Do not enter the disregarded entity's EIN. If the LLC is classified as a corporation or partnership, enter the entity's EIN.

Note. See the chart on page 4 for further clarification of name and TIN combinations.

How to get a TIN. If you do not have a TIN, apply for one immediately. To apply for an SSN, get Form SS-5, Application for a Social Security Card, from your local SSA office or get this form online at www.ssa.gov. You may also get this form by calling 1-800-772-1213. Use Form W-7, Application for IRS Individual Taxpayer Identification Number, to apply for an ITIN, or Form SS-4, Application for Employer Identification Number, to apply for an EIN. You can apply for an EIN online by accessing the IRS website at www.irs.gov/businesses and clicking on Employer Identification Number (EIN) under Starting a Business. You can get Forms W-7 and SS-4 from the IRS by visiting IRS.gov or by calling 1-800-TAX-FORM (1-800-829-3676).

If you are asked to complete Form W-9 but do not have a TIN, apply for a TIN and write "Applied For" in the space for the TIN, sign and date the form, and give it to the requester. For interest and dividend payments, and certain payments made with respect to readily tradable instruments, generally you will have 60 days to get a TIN and give it to the requester before you are subject to backup withholding on payments. The 60-day rule does not apply to other types of payments. You will be subject to backup withholding on all such payments until you provide your TIN to the requester.

Note. Entering "Applied For" means that you have already applied for a TIN or that you intend to apply for one soon.

Caution: A disregarded U.S. entity that has a foreign owner must use the appropriate Form W-8.

Part II. Certification

To establish to the withholding agent that you are a U.S. person, or resident alien, sign Form W-9. You may be requested to sign by the withholding agent even if items 1, 4, or 5 below indicate otherwise.

For a joint account, only the person whose TIN is shown in Part I should sign (when required). In the case of a disregarded entity, the person identified on line 1 must sign. Exempt payees, see *Exempt payee code* earlier.

Signature requirements. Complete the certification as indicated in items 1 through 5 below.

1. Interest, dividend, and barter exchange accounts opened before 1984 and broker accounts considered active during 1983. You must give your correct TIN, but you do not have to sign the certification.

2. Interest, dividend, broker, and barter exchange accounts opened after 1983 and broker accounts considered inactive during 1983. You must sign the certification or backup withholding will apply. If you are subject to backup withholding and you are merely providing your correct TIN to the requester, you must cross out item 2 in the certification before signing the form.

3. Real estate transactions. You must sign the certification. You may cross out item 2 of the certification.

4. Other payments. You must give your correct TIN, but you do not have to sign the certification unless you have been notified that you have previously given an incorrect TIN. "Other payments" include payments made in the course of the requester's trade or business for rents, royalties, goods (other than bills for merchandise), medical and health care services (including payments to corporations), payments to a nonemployee for services, payments made in settlement of payment card and third party network transactions, payments to certain fishing boat crew members and fishermen, and gross proceeds paid to attorneys (including payments to corporations).

5. Mortgage interest paid by you, acquisition or abandonment of secured property, cancellation of debt, qualified tuition program payments (under section 529), IRA, Coverdell ESA, Archer MSA or HSA contributions or distributions, and pension distributions. You must give your correct TIN, but you do not have to sign the certification.

What Name and Number To Give the Requester

For this type of account:	Give name and SSN of:
1. Individual	The individual
2. Two or more individuals (joint account)	The actual owner of the account or, if combined funds, the first individual on the account ¹
3. Custodian account of a minor (Uniform Gift to Minors Act)	The minor ²
4. a. The usual revocable savings trust (grantor is also trustee) b. So-called trust that is not a legal or valid trust under state law	The grantor-trustee ¹ The actual owner ¹
5. Sole proprietorship or disregarded entity owned by an individual	The owner ²
6. Grantor trust filing under Optional Form 1099 Filing Method 1 (see Regulations section 1.671-4(b)(2)(i)(A))	The grantor ²
For this type of account:	Give name and EIN of:
7. Disregarded entity not owned by an individual	The owner
8. A valid trust, estate, or pension trust	Legal entity ⁴
9. Corporation or LLC electing corporate status on Form 8832 or Form 2553	The corporation
10. Association, club, religious, charitable, educational, or other tax-exempt organization	The organization
11. Partnership or multi-member LLC	The partnership
12. A broker or registered nominee	The broker or nominee
13. Account with the Department of Agriculture in the name of a public entity (such as a state or local government, school district, or prison) that receives agricultural program payments	The public entity
14. Grantor trust filing under the Form 1041 Filing Method or the Optional Form 1099 Filing Method 2 (see Regulations section 1.671-4(b)(2)(i)(B))	The trust

¹ List first and circle the name of the person whose number you furnish. If only one person on a joint account has an SSN, that person's number must be furnished.
² Circle the minor's name and furnish the minor's SSN.

³ You must show your individual name and you may also enter your business or DBA name on the "Business name/disregarded entity" name line. You may use either your SSN or EIN (if you have one), but the IRS encourages you to use your SSN.

⁴ List first and circle the name of the trust, estate, or pension trust. (Do not furnish the TIN of the personal representative or trustee unless the legal entity itself is not designated in the account title.) Also see *Special rules for partnerships* on page 2.

*Note. Grantor also must provide a Form W-9 to trustee of trust.

Note. If no name is circled when more than one name is listed, the number will be considered to be that of the first name listed.

Secure Your Tax Records from Identity Theft

Identity theft occurs when someone uses your personal information such as your name, SSN, or other identifying information, without your permission, to commit fraud or other crimes. An identity thief may use your SSN to get a job or may file a tax return using your SSN to receive a refund.

To reduce your risk:

- Protect your SSN,
- Ensure your employer is protecting your SSN, and
- Be careful when choosing a tax preparer.

If your tax records are affected by identity theft and you receive a notice from the IRS, respond right away to the name and phone number printed on the IRS notice or letter.

If your tax records are not currently affected by identity theft but you think you are at risk due to a lost or stolen purse or wallet, questionable credit card activity or credit report, contact the IRS Identity Theft Hotline at 1-800-908-4490 or submit Form 14039.

For more information, see Publication 4535, Identity Theft Prevention and Victim Assistance.

Victims of identity theft who are experiencing economic harm or a system problem, or are seeking help in resolving tax problems that have not been resolved through normal channels, may be eligible for Taxpayer Advocate Service (TAS) assistance. You can reach TAS by calling the TAS toll-free case intake line at 1-877-777-4778 or TTY/TDD 1-800-829-4059.

Protect yourself from suspicious emails or phishing schemes. Phishing is the creation and use of email and websites designed to mimic legitimate business emails and websites. The most common act is sending an email to a user falsely claiming to be an established legitimate enterprise in an attempt to scam the user into surrendering private information that will be used for identity theft.

The IRS does not initiate contacts with taxpayers via emails. Also, the IRS does not request personal detailed information through email or ask taxpayers for the PIN numbers, passwords, or similar secret access information for their credit card, bank, or other financial accounts.

If you receive an unsolicited email claiming to be from the IRS, forward this message to phishing@irs.gov. You may also report misuse of the IRS name, logo, or other IRS property to the Treasury Inspector General for Tax Administration (TIGTA) at 1-800-366-4484. You can forward suspicious emails to the Federal Trade Commission at: spam@uce.gov or contact them at www.ftc.gov/idtheft or 1-877-IDTHEFT (1-877-438-4338).

Visit IRS.gov to learn more about identity theft and how to reduce your risk.

Privacy Act Notice

Section 6109 of the Internal Revenue Code requires you to provide your correct TIN to persons (including federal agencies) who are required to file information returns with the IRS to report interest, dividends, or certain other income paid to you; mortgage interest you paid; the acquisition or abandonment of secured property; the cancellation of debt; or contributions you made to an IRA, Archer MSA, or HSA. The person collecting this form uses the information on the form to file information returns with the IRS, reporting the above information. Routine uses of this information include giving it to the Department of Justice for civil and criminal litigation and to cities, states, the District of Columbia, and U.S. commonwealths and possessions for use in administering their laws. The information also may be disclosed to other countries under a treaty, to federal and state agencies to enforce civil and criminal laws, or to federal law enforcement and intelligence agencies to combat terrorism. You must provide your TIN whether or not you are required to file a tax return. Under section 3406, payers must generally withhold a percentage of taxable interest, dividend, and certain other payments to a payee who does not give a TIN to the payer. Certain penalties may also apply for providing false or fraudulent information.

Job No.: 21-048

TAX FORM/DEBT/ RESIDENCE CERTIFICATION
(for Advertised Projects)

Taxpayer Identification Number (T.I.N.): 63--0513868

Company Name submitting Bid/Proposal: Vulcan Inc. DBA Vulcan Aluminum, Vulcan Signs

Mailing Address: P.O. Box 1850 Foley, AL 36536-1850

Are you registered to do business in the State of Texas? **Yes** No

If you are an individual, list the names and addresses of any partnership of which you are a general partner or any assumed name(s) under which you operate your business

I. **Property:** List all taxable property in Fort Bend County owned by you or above partnerships as well as any d/b/a names. Include real and personal property as well as mineral interest accounts. (Use a second sheet of paper if necessary.)

<u>Fort Bend County Tax Acct. No.*</u>	<u>Property address or location**</u>
_____	_____
_____	_____
_____	_____
_____	_____

* This is the property account identification number assigned by the Fort Bend County Appraisal District.
 ** For real property, specify the property address or legal description. For business personal property, specify the address where the property is located. For example, office equipment will normally be at your office, but inventory may be stored at a warehouse or other location.

II. **Fort Bend County Debt** - Do you owe any debts to Fort Bend County (taxes on properties listed in I above, tickets, fines, tolls, court judgments, etc.)?

Yes **No** If yes, attach a separate page explaining the debt.

III. **Residence Certification** - Pursuant to Texas Government Code §2252.001 *et seq.*, as amended, Fort Bend County requests Residence Certification. §2252.001 *et seq.* of the Government Code provides some restrictions on the awarding of governmental contracts; pertinent provisions of §2252.001 are stated below:

- (3) "Nonresident bidder" refers to a person who is not a resident.
- (4) "Resident bidder" refers to a person whose principal place of business is in this state, including a contractor whose ultimate parent company or majority owner has its principal place of business in this state.

I certify that _____ is a Resident Bidder of Texas as defined in Government Code §2252.001.
[Company Name]

I certify that Vulcan, Inc. is a Nonresident Bidder as defined in Government Code §2252.001 and our principal place of business is Foley, AL.
[Company Name] [City and State]

**Fort Bend County Pricing Form
 BID 21-048
 Term Contract for Traffic Signs, Posts and Supplies**

Vendor Name: Vulcan Inc., DBA Vulcan Signs

Section 1: Complete Signs Finished traffic signs must be .080 aluminum with faces, diamond grade, VIP, reflective sheeting. Add 3M protective overlay film (series 1160) to each sign.	Estimated Annual Quantity	Bid Price per Each	Extended Cost
All way, 18 x 6, red white VIP diamond Grade (MUTCD R1-4)	400	\$5.70	\$ 2,280.00
Watch for ice on bridge, 36 x 36, hinged with closure hook, fluorescent yellow, diamond grade material	100	\$88.80	\$ 8,880.00
Type III, 12x36, fluorescent yellow, DG3, (MUTCD OM-3R)	50	\$23.07	\$ 1,153.50
Type III, 12x36, fluorescent yellow, DG3, (MUTCD OM-3L)	50	\$23.07	\$ 1,153.50
Total Section 1:			\$ 13,467.00

Vendor Name: Vulcan Inc., DBA Vulcan Aluminum

Section 2: Blanks Blanks must be .080 aluminum	Estimated Annual Quantity	Bid Price per Each	Extended Cost
Blanks, rounded corners, diamond punch 18 x 18	1000	\$9.39	\$ 9,390.00
Blanks, rounded corners, diamond punch 24 x 24	1000	\$16.63	\$ 16,630.00
Blanks, rounded corners, diamond punch 30 x 30	1000	\$26.12	\$ 26,120.00
Blanks, rounded corners, diamond punch 36 x 36	500	\$37.77	\$ 18,885.00
Blanks, octagon 30 x 30	1000	\$23.58	\$ 23,580.00
Blanks, octagon 36 x 36	300	\$33.94	\$ 10,182.00
Blanks, pentagon 30 x 30	300	\$22.97	\$ 6,891.00
Blanks, pentagon 36 x 36	65	\$33.01	\$ 2,145.65
Blanks, rounded corners, rectangle 24 x 8	400	\$5.55	\$ 2,220.00
Blanks, rounded corners, rectangle 24 x 10	400	\$6.94	\$ 2,776.00
Blanks, rounded corners, rectangle 24 x 12	400	\$8.32	\$ 3,328.00
Blanks, rounded corners, rectangle 12 x 18	400	\$6.26	\$ 2,504.00
Blanks, rounded corners, rectangle 18 x 24	400	\$12.48	\$ 4,992.00
Blanks, rounded corners, rectangle 24 x 30	1000	\$20.90	\$ 20,900.00
Blanks, rounded corners, rectangle 24 x 36	300	\$25.37	\$ 7,611.00
Blanks, rounded corners, rectangle 30 x 36	100	\$31.73	\$ 3,173.00
Blanks, rounded corners, rectangle 24 x 48	500	\$33.53	\$ 16,765.00
Blanks, rounded corners, rectangle 30 x 48	100	\$41.97	\$ 4,197.00
Blanks, rounded corners, rectangle 36 x 18	500	\$18.76	\$ 9,380.00
Blanks, rounded corners, square 18 x 18	1000	\$9.39	\$ 9,390.00
Blanks, rounded corners, square 24 x 24	1000	\$16.63	\$ 16,630.00
Blanks, rounded corners, street sign, flat, 9 x 30	600	\$7.84	\$ 4,704.00
Blanks, rounded corners, street sign, flat, 9 x 36	600	\$9.39	\$ 5,634.00
Blanks, rounded corners, street sign, flat, 9 x 42	600	\$11.48	\$ 6,888.00
Blanks, rounded corners, street sign, flat, 9 x 48	600	\$12.86	\$ 7,716.00
Blanks, round, 36" diameter	300	\$33.16	\$ 9,948.00
Blanks, rounded corners, rectangle, 10 x 30	300	\$8.71	\$ 2,613.00
Blanks, rounded corners, rectangle, 12 x 30	300	\$10.45	\$ 3,135.00
Blanks, rounded corners, triangle, 30	500	\$12.25	\$ 6,125.00
Blanks, rounded corners, triangle, 36	500	\$17.37	\$ 8,685.00
Blanks, extruded, 9 x 30	1000	\$6.16	\$ 6,160.00
Blanks, extruded, 9 x 36	1000	\$7.40	\$ 7,400.00
Blanks, extruded, 9 x 42	1000	\$8.63	\$ 8,630.00
Blanks, extruded, 9 x 48	1000	\$9.85	\$ 9,850.00
Blanks, extruded, 9 x 54	1000	\$11.10	\$ 11,100.00
Total Section 2:			\$ 316,277.65

Vendor Name: Vulcan Inc., DBA Vulcan Signs

Section 3: Posts and Accessories-Telespar Sign Support System	Estimated Annual Quantity	Bid Price per Each	Extended Cost
12' Round 2.375 16 gauge galvanized post	500	26.44	\$ 13,220.00
14' 1-3/4"x1-3/4" square 12 gauge galvanized sign post	500	42.48	\$ 21,240.00
12" round post cap flat blade for 2.375" round post	500	8.73	\$ 4,365.00
12" round post cap extruded for 2.375" round post	500	8.73	\$ 4,365.00
**74-5606 TRF RD RW 2.375 16 gauge Post, 12'	500	\$26.44	\$ 13,220.00
75-4892 TRF RD Taper 2.875 Poz Loc Sockets	500	\$19.38	\$ 9,690.00
76-6050 6603 RD Post Shim W/9/16" Hole Wedges	500	\$3.50	\$ 1,750.00
Square sign post, 12 ft., 12 gauge, galvanized steel, pre-punched, 1-3/4" x 1-3/4"	1500	\$37.18	\$ 55,770.00
U channel galvanized steel post 7 ft. 1.12 lbs.	1500	\$8.91	\$ 13,365.00
Square post caps, 5-1/2" blade, flat with set screws	1500	\$3.37	\$ 5,055.00
Square post caps, 5-1/2" blade, extruded with set screws	1500	\$3.37	\$ 5,055.00
Round post caps for flat with set screws, 2-3/8" post OD for 5-1/2" blade	500	\$3.37	\$ 1,685.00
Round post caps for extruded with set screws, 2-3/8" post OD for 5-1/2" blade	500	\$3.37	\$ 1,685.00
Small corner bolts	4500	\$0.45	\$ 2,025.00
Flanged nuts	4500	\$0.10	\$ 450.00
Anchors: 1-7/8" x 1-7/8" x 36"	5000		\$ -
Drive Rivets, 3/8" aluminum	20000	\$0.45	\$ 9,000.00
Cross brackets for street signs, 5-1/2" blade holder with set screws for flat	1000	\$3.37	\$ 3,370.00
Cross brackets for street signs, 5-1/2" blade holder with set screws for extruded	1000	\$3.37	\$ 3,370.00
Cross brackets for street signs, 12" blade holder with set screws for flat	1000	\$8.72	\$ 8,720.00
Cross brackets for street signs, 12" blade holder with set screws for extruded	1000	\$8.72	\$ 8,720.00
2-7/8" OD, rounded, for flat blades, 5-1/2" blade holder with set screws	1000	\$3.37	\$ 3,370.00
2-3/8" OD, round 12" post caps for flat blade with set screws	1000	\$8.72	\$ 8,720.00
2-3/8" OD, round 12" post caps for extruded with set screws	1000	\$8.72	\$ 8,720.00
12" blade for flat street signs, square post cap, 1-3/4"	1000	\$8.72	\$ 8,720.00
12" blade for extruded street signs, square post cap, 1-3/4"	1000	\$8.72	\$ 8,720.00
2-3/8" post clamp with fasteners included with each clamp, aluminum	1000	\$1.97	\$ 1,970.00
Total Section 3:			\$ 226,340.00

Vendor Name:

Section 4: Construction Supplies	Estimated Annual Quantity	Bid Price per Each	Extended Cost
Barricade, portable type I standard 36" plastic with reflective DG3 diamond grade sheeting with aluminum	200		\$ -
Barricade, Type III collapsible, diamond grade reflective sheeting, no-maintenance plastic boards, 8 foot, double sided sheeting right and left with Telespar tubing for upright support and legs, 1" thick x 8" tall board	100		\$ -
Barricade, Type III collapsible, diamond grade reflective sheeting, no-maintenance plastic boards, 10 foot, double sided sheeting right and left with Telespar tubing for upright support and legs, 1" thick x 8" tall board	100		\$ -
Barricade, Type III collapsible, diamond grade reflective sheeting, no-maintenance plastic boards, 12 foot, double sided sheeting right and left with Telespar tubing for upright support and legs, 1" thick x 8" tall board	100		\$ -
End of Road barricade boards, Type III with DG3 diamond grade sheeting on no-maintenance plastic boards, 10', red and white, 1" thick x 8" tall board, 3 right boards	100		\$ -
End of Road barricade boards, Type III with DG3 diamond grade sheeting on no-maintenance plastic boards, 10', red and white, 1" thick x 8" tall board, 3 left boards	100		\$ -
Barricade, two (2) "A" frames with two (2) 10' diamond grade sheeted I-beams, molded no-maintenance plastic boards, orange and white, right on one side and left on other side	100		\$ -
Safety cones, 28", orange, 12# weight, 4" upper reflective collars, with white diamond grade VIP reflective sheeting, 14-3/4" x 14-3/4" base	100		\$ -
Safety cones, 28", orange, 12# weight, 6" upper reflective collars, with white diamond grade VIP reflective sheeting, 14-3/4" x 14-3/4" base	100		\$ -
Safety cones, 36", orange, 12# weight, 4" upper reflective collars, with white diamond grade VIP reflective sheeting, 14-3/4" x 14-3/4" base	100		\$ -
Safety cones, 36", orange, 12# weight, 6" upper reflective collars, with white diamond grade VIP reflective sheeting, 14-3/4" x 14-3/4" base	100		\$ -

Vendor Name:

Section 4: Construction Supplies (cont'd)	Estimated Annual Quantity	Bid Price per each	Extended Cost
Vertical Panel with 20" x 28" black rubber rectangular base, reflective panel 8" x 36", orange and white diagonal sheeting, double sided, diamond grade reflective sheeting,	300		\$ -
Warning light, Colt RS-600, 6 volt type A	200		\$ -
Warning light spring battery, general purpose 6 volt type	200		\$ -
Delineator reflectors, 4" x 4", white aluminum with diamond grade sheeting	2000		\$ -
Delineator reflectors, 4" x 4", fluorescent yellow aluminum with diamond grade sheeting	2000		\$ -
Standard roll up construction signs, 48 x 48 reflective, vinyl, plastic corner pockets with ribs with overlays, fluorescent orange. All construction signs in the Texas Manual on Uniform Traffic Control with carrying bags	100		\$ -
Standard roll up construction signs, 36 x 36 reflective, vinyl, plastic corner pockets with ribs with overlays, fluorescent orange. All construction signs in the Texas Manual on Uniform Traffic Control with carrying bags	50		\$ -
DF3000W 12" Screwlock Roll-Up Sign Stand	15		\$ -
DF3003W 12" Screwlock Roll-Up Sign Stand	15		\$ -
DF3000S 12" Stablock Fold & Roll Sign Stand	15		\$ -
DF3003S 12" Stablock Fold & Roll Sign Stand	15		\$ -
DF4503 5" RUB3315 Roll-Up Sign Stand	15		\$ -
DF4700TX 7" RUB3315 Roll-Up Sign Stand	15		\$ -
Chip seal markers, white with cover, two sided	5000		\$ -
Chip seal markers, yellow with cover, two sided	5000		\$ -
Total Section 4:			\$ -

NO BID
THIS PAGE

NO BID
THIS PAGE

Section 5: Carsonite Products or equal (See Section 1.18 Name Brands)	Estimated Annual Quantity	Bid Price per Each	Extended Cost
Road markers, white, Carsonite CRM-375., flexible 3.75" width x 62" length, with 3" x 12" fluorescent yellow reflective diamond grade VIP installed	1500		\$ -
Total Section 5:			\$ -

Vendor Name: Vulcan Inc., DBA Vulcan Signs

Section 6: 3M Products	Estimated Annual Quantity	Bid Price per Each	Extended Cost
Rolls, 30", red, reflective series DG3 cubed, pressure sensitive	20	\$1,053.75	\$ 21,075.00
Rolls, 30" x 50 yd., white, engineer grade, pressure sensitive, #3200T	10	\$292.50	\$ 2,925.00
Rolls, 36" x 50 yd., white, engineer grade, pressure sensitive, #3200T	10	\$351.00	\$ 3,510.00
Rolls, 9", white, reflective, series DG3 cubed, pressure sensitive	20	\$316.13	\$ 6,322.60
Rolls, 24", white, reflective, series DG3 cubed, pressure sensitive	20	\$843.00	\$ 16,860.00
Rolls, 30", white, reflective series DG3 cubed, pressure sensitive	20	\$1,053.75	\$ 21,075.00
Rolls, 36", white, reflective series DG3 cubed, pressure sensitive	20	\$1,264.50	\$ 25,290.00
Rolls, 9", yellow, reflective, engineer grade, pressure sensitive, #3200T	5	\$87.75	\$ 438.75
Rolls, 9", yellow, reflective, series DG3 cubed, pressure sensitive	5	\$316.13	\$ 1,580.65
Rolls, 18", yellow, reflective, series DG3 cubed, pressure sensitive	10	\$632.25	\$ 6,322.50
Rolls, 24", yellow, reflective, series DG3 cubed, pressure sensitive	10	\$843.00	\$ 8,430.00
Rolls, 30", yellow, reflective, series DG3 cubed, pressure sensitive	10	\$1,053.75	\$ 10,537.50
Rolls, 36", yellow, reflective, series DG3 cubed, pressure sensitive	5	\$1,264.50	\$ 6,322.50
Rolls, 9", fluorescent yellow, reflective, series DG3 cubed, pressure sensitive	5	\$316.13	\$ 1,580.65
Rolls, 18", fluorescent yellow, reflective, series DG3 cubed, pressure sensitive	5	\$632.25	\$ 3,161.25
Rolls, 24", fluorescent yellow, reflective, series DG3 cubed, pressure sensitive	5	\$843.00	\$ 4,215.00
Rolls, 30", fluorescent yellow, reflective, series DG3 cubed, pressure sensitive	5	\$1,053.75	\$ 5,268.75
Rolls, 36", fluorescent yellow, reflective, series DG3 cubed, pressure sensitive	5	\$1,264.50	\$ 6,322.50
Rolls, 24", fluorescent yellow green, reflective, series DG3 cubed, pressure sensitive	5	\$843.00	\$ 4,215.00
Rolls, 30", fluorescent yellow green, reflective, series DG3 cubed, pressure sensitive	5	\$1,053.73	\$ 5,268.65

Vendor Name: Vulcan Inc., DBA Vulcan Signs

Section 6: 3M Products (cont'd)	Estimated Annual Quantity	Bid Price per Each	Extended Cost
Rolls, 18", fluorescent orange, reflective, series DG3 cubed, pressure sensitive	6	\$632.25	\$ 3,793.50
Rolls, 30", fluorescent orange, reflective, series DG3 cubed, pressure sensitive	6	\$1,053.75	\$ 6,322.50
Rolls, 36", fluorescent orange, reflective, series DG3 cubed, pressure sensitive	6	\$1,264.50	\$ 7,587.00
Rolls, 18", black, non-reflective, vinyl, clear synthetic	5		\$ -
Rolls, 24", black, non-reflective, vinyl, clear synthetic	5	\$318.57	\$ 1,592.85
Rolls, 30", black, non-reflective, vinyl, clear synthetic	5	\$398.20	\$ 1,991.00
Rolls, 36", black, non-reflective, vinyl, clear synthetic	5	\$477.85	\$ 2,389.25
Rolls, 30", white, non-reflective, vinyl, clear synthetic	10	\$398.20	\$ 3,982.00
Rolls, 9", transfer tape, clear	60	\$65.25	\$ 3,915.00
Rolls, 12", transfer tape, clear	60	\$87.00	\$ 5,220.00
Rolls, 24", transfer tape, clear TPM5 transfer	50	\$174.00	\$ 8,700.00
Rolls, 30", transfer tape, clear TPM5	50	\$217.50	\$ 10,875.00
Rolls, 36", transfer tape, clear TPM5	50	\$261.00	\$ 13,050.00
24", E C film, brown, clear synthetic liner	6	\$276.00	\$ 1,656.00
30", E C film, brown, clear synthetic liner	6	\$345.00	\$ 2,070.00
24", E C film, green, clear synthetic liner	20	\$276.00	\$ 5,520.00
30", E C film, green, clear synthetic liner	6	\$345.00	\$ 2,070.00
24", E C film, blue, clear synthetic liner	6	\$276.00	\$ 1,656.00
30", E C film, blue, clear synthetic liner	6	\$345.00	\$ 2,070.00
24", E C film, red, clear synthetic liner	6	\$276.00	\$ 1,656.00
30", E C film, red, clear synthetic liner	6	\$345.00	\$ 2,070.00
36", E C film, red, clear synthetic liner	6	\$414.00	\$ 2,484.00
2" roll, red/white, conspicuity marking, series DG3 cubed, pressure sensitive, red/white block, 6" x 6", 983-32	6	\$113.89	\$ 683.34

Vendor Name: Vulcan Inc., DBA Vulcan Signs

Section 6: 3M Products (cont'd)	Estimated Annual Quantity	Bid Price per Each	Extended Cost
Faces (Faces only NOT complete signs, Does Not include blank) Faces must be pressure sensitive, series DG3 cubed, reflective sheeting and packaged with slip sheeting. Must be packaged with plastic washers.			
Faces: Stop ahead (symbol), 30" fluorescent yellow, series DG3 cubed, material Symbol MUTCD W3-1A	300	\$18.98	\$ 5,694.00
Faces: Stop ahead (symbol), 36" fluorescent yellow, series DG3 cubed, material Symbol MUTCD W3-1A	300	\$26.86	\$ 8,058.00
Faces: Stop sign, 30 x 30, series DG3 cubed, pre-cut corners	1000	\$17.94	\$ 17,940.00
Faces: Stop sign, 36 x 36, series DG3 cubed, pre-cut corners	300	\$25.83	\$ 7,749.00
Faces: Yield, 30 x 30	300	\$9.13	\$ 2,739.00
Faces: Signals ahead, 30 x 30 fluorescent yellow, series DG3 cubed, Symbol MUTCD W3-3	300	\$19.48	\$ 5,844.00
Faces: White body raised pavement markings, one-way white lens, 100 per carton	10	\$205.00	\$ 2,050.00
Faces: White body raised pavement markings, two-way white lens, 100 per carton	10	\$205.00	\$ 2,050.00
Faces: White body raised pavement markings, two-way white/red lens, 100 per carton	10	\$205.00	\$ 2,050.00
Faces: Yellow body raised pavement markings, one-way yellow lens, 100 per carton	10	\$205.00	\$ 2,050.00
Faces: Yellow body raised pavement markings, two-way yellow lens, 100 per carton	10	\$205.00	\$ 2,050.00
Faces: One way pressure sensitive adhesive raised pavement markers white lens, 100 per carton	10	\$205.00	\$ 2,050.00
Faces: One way pressure sensitive adhesive raised pavement markers yellow lens, 100 per carton	10	\$205.00	\$ 2,050.00
Faces: One way pressure sensitive adhesive raised pavement markers red lens, 100 per carton	10	\$205.00	\$ 2,050.00
Faces: Two way pressure sensitive adhesive raised pavement markers white lens, 100 per carton	10	\$205.00	\$ 2,050.00
Faces: Two way pressure sensitive adhesive raised pavement markers yellow lens, 100 per carton	10	\$205.00	\$ 2,050.00
3M protective overlay film (series 1160), 30" x 50 yards per roll	10	\$517.50	\$ 5,175.00
3M protective overlay film (series 1160), 36" x 50 yards per roll	10	\$621.00	\$ 6,210.00
3M citrus base cleaner (aerosol)	100		\$ -

Vendor Name: Vulcan Inc., DBA Vulcan Signs

Section 6: 3M Products (cont'd)	Estimated Annual Quantity	Bid Price per Each	Extended Cost
Faces (Faces only NOT complete signs, Does Not include blank) Faces must be pressure sensitive, series DG3 cubed, reflective sheeting and packaged with slip sheeting. Must be packaged with plastic washers. Add 3M protective overlay film (series 1160) to each sign face.			
Faces: Stop ahead (symbol), 30" fluorescent yellow, series DG3 cubed, material Symbol MUTCD W3-1A	1000	\$30.78	\$ 30,780.00
Faces: Stop ahead (symbol), 36" fluorescent yellow, series DG3 cubed, material Symbol MUTCD W3-1A	1000	\$43.85	\$ 43,850.00
Faces: Stop sign, 30 x 30, series DG3 cubed, pre-cut corners	1000	\$29.81	\$ 29,810.00
Faces: Stop sign, 36 x 36, series DG3 cubed, pre-cut corners	1000	\$42.93	\$ 42,930.00
Faces: Yield, 30 x 30	1000	\$15.17	\$ 15,170.00
Faces: Yield, 36 x 36	500	\$20.99	\$ 10,495.00
Faces: Signals ahead, 30 x 30 fluorescent yellow, series DG3 cubed, Symbol MUTCD W3-3	1000	\$31.28	\$ 31,280.00
Faces: White body raised pavement markings, one-way white lens, 100 per carton	10	\$205.00	\$ 2,050.00
Faces: White body raised pavement markings, two-way white lens, 100 per carton	10	\$205.00	\$ 2,050.00
Faces: White body raised pavement markings, two-way white/red lens, 100 per carton	10	\$205.00	\$ 2,050.00
Faces: Yellow body raised pavement markings, one-way yellow lens, 100 per carton	10	\$205.00	\$ 2,050.00
Faces: Yellow body raised pavement markings, two-way yellow lens, 100 per carton	10	\$205.00	\$ 2,050.00
Faces: One way pressure sensitive adhesive raised pavement markers white lens, 100 per carton	10	\$205.00	\$ 2,050.00
Faces: One way pressure sensitive adhesive raised pavement markers yellow lens, 100 per carton	10	\$205.00	\$ 2,050.00
Faces: One way pressure sensitive adhesive raised pavement markers red lens, 100 per carton	10	\$205.00	\$ 2,050.00
Faces: Two way pressure sensitive adhesive raised pavement markers white lens, 100 per carton	10	\$205.00	\$ 2,050.00
Faces: Two way pressure sensitive adhesive raised pavement markers yellow lens, 100 per carton	10	\$205.00	\$ 2,050.00
Total Section 6:			\$ 556,798.74

Vendor Name: Vulcan Inc., DBA Vulcan Signs

Section 7: Avery Denison	Estimated Annual Quantity	Bid Price per Each	Extended Cost
Rolls, 30" x 50 yd., white, engineer grade, pressure sensitive, #3200T	10	\$292.50	\$ 2,925.00
Rolls, 36" x 50 yd., white, engineer grade, pressure sensitive, #3200T	10	\$351.00	\$ 3,510.00
Rolls, 9", white, reflective, series DG3 cubed, pressure sensitive	20	\$316.13	\$ 6,322.60
Rolls, 24", white, reflective, series DG3 cubed, pressure sensitive	20	\$843.00	\$ 16,860.00
Rolls, 30", white, reflective, series DG3 cubed, pressure sensitive	20	\$1,053.75	\$ 21,075.00
Rolls, 36", white, reflective, series DG3 cubed, pressure sensitive	20	\$1,264.50	\$ 25,290.00
Rolls, 9", yellow, reflective, engineer grade, pressure sensitive, #3200T	5	\$87.75	\$ 438.75
Rolls, 9", yellow, reflective, series DG3 cubed, pressure sensitive	5	\$316.13	\$ 1,580.65
Rolls, 18", yellow, reflective, series DG3 cubed, pressure Sensitive	10	\$632.25	\$ 6,322.50
Rolls, 24", yellow, reflective, series DG3 cubed, pressure Sensitive	10	\$843.00	\$ 8,430.00
Rolls, 30", yellow, reflective, series DG3 cubed, pressure Sensitive	10	\$1,053.75	\$ 10,537.50
Rolls, 36", yellow, reflective, series DG3 cubed, pressure Sensitive	10	\$1,264.50	\$ 12,645.00
Rolls, 9", fluorescent yellow, reflective, series DG3 cubed, pressure sensitive	10	\$316.13	\$ 3,161.30
Rolls, 18", fluorescent yellow, reflective, series DG3 cubed, pressure sensitive	10	\$632.25	\$ 6,322.50
Rolls, 24", fluorescent yellow, reflective, series DG3 cubed, pressure sensitive	10	\$843.00	\$ 8,430.00
Rolls, 30", fluorescent yellow, reflective, series DG3 cubed, pressure sensitive	10	\$1,053.75	\$ 10,537.50
Rolls, 36", fluorescent yellow, reflective, series DG3 cubed, pressure sensitive	10	\$1,264.50	\$ 12,645.00
Rolls, 24", fluorescent yellow green, reflective, series DG3 cubed, pressure sensitive	10	\$843.00	\$ 8,430.00
Rolls, 30", fluorescent yellow green, reflective, series DG3 cubed, pressure sensitive	10	\$1,053.75	\$ 10,537.50
Rolls, 18", fluorescent orange, reflective, series DG3 cubed, pressure sensitive	10	\$632.25	\$ 6,322.50
Rolls, 30", fluorescent orange, reflective, series DG3 cubed, pressure sensitive	10	\$1,053.75	\$ 10,537.50

Vendor Name: Vulcan Inc., DBA Vulcan Signs

Section 7: Avery Denison (cont'd)	Estimated Annual Quantity	Bid Price per Each	Extended Cost
Rolls, 36", fluorescent orange, reflective, series DG3 cubed, pressure sensitive	10	\$1,264.50	\$ 12,645.00
Rolls, 18", black, non-reflective, vinyl, clear synthetic	10		\$ -
Rolls, 24", black, non-reflective, vinyl, clear synthetic	10	\$318.57	\$ 3,185.70
Rolls, 30", black, non-reflective, vinyl, clear synthetic	10	\$398.20	\$ 3,982.00
Rolls, 36", black, non-reflective, vinyl, clear synthetic	10	\$477.85	\$ 4,778.50
Rolls, 30", white, non-reflective, vinyl, clear synthetic	10	398.2	\$ 3,982.00
Rolls, 9", transfer tape, clear	60	65.25	\$ 3,915.00
Rolls, 12", transfer tape, clear	60	87	\$ 5,220.00
24", E C film, brown, clear synthetic liner	6	276	\$ 1,656.00
30", E C film, brown, clear synthetic liner	6	345	\$ 2,070.00
24", E C film, green, clear synthetic liner	6	276	\$ 1,656.00
30", E C film, green, clear synthetic liner	6	345	\$ 2,070.00
24", E C film, blue, clear synthetic liner	6	276	\$ 1,656.00
30", E C film, blue, clear synthetic liner	6	345	\$ 2,070.00
24", E C film, red, clear synthetic liner	6	276	\$ 1,656.00
30", E C film, red, clear synthetic liner	6	345	\$ 2,070.00
36", E C film, red, clear synthetic liner	6	414	\$ 2,484.00
2" roll, red/white, conspicuity marking, series DG3 cubed, pressure sensitive, red/white block, 6" x 6", 983-32	6	113.89	\$ 683.34

*Transfer tape quoted in 100 yd rolls.

Vendor Name: Vulcan Inc., DBA Vulcan Signs

Section 7: Avery Denison (cont'd)	Estimated Annual Quantity	Bid Price per Each	Extended Cost
Faces (Faces only NOT complete signs, Does Not include blank) Faces must be pressure sensitive, series DG3 cubed, reflective sheeting and packaged with slip sheeting. Must be packaged with plastic washers.			
Faces: Stop ahead (symbol), 30" fluorescent yellow, series DG3 cubed, material Symbol MUTCD W3-1A	300	\$18.98	\$ 5,694.00
Faces: Stop sign, 30 x 30, series DG3 cubed, pre-cut corners	1000	\$17.94	\$ 17,940.00
Faces: Stop sign, 36 x 36, series DG3 cubed, pre-cut corners	300	\$25.83	\$ 7,749.00
Faces: Yield, 30 x 30	300	\$9.13	\$ 2,739.00
Faces: Signals ahead, 30 x 30 fluorescent yellow, series DG3 cubed, Symbol MUTCD W3-3	300	\$19.48	\$ 5,844.00
Faces: White body raised pavement markings, one-way white lens, 100 per carton	10	\$205.00	\$ 2,050.00
Faces: White body raised pavement markings, two-way white lens, 100 per carton	10	\$205.00	\$ 2,050.00
Faces: White body raised pavement markings, two-way white/red lens, 100 per carton	10	\$205.00	\$ 2,050.00
Faces: Yellow body raised pavement markings, one-way yellow lens, 100 per carton	10	\$205.00	\$ 2,050.00
Faces: Yellow body raised pavement markings, two-way yellow lens, 100 per carton	10	\$205.00	\$ 2,050.00
Faces: One way pressure sensitive adhesive raised pavement markers white lens, 100 per carton	10	\$205.00	\$ 2,050.00
Faces: One way pressure sensitive adhesive raised pavement markers yellow lens, 100 per carton	10	\$205.00	\$ 2,050.00
Faces: One way pressure sensitive adhesive raised pavement markers red lens, 100 per carton	10	\$205.00	\$ 2,050.00
Faces: Two way pressure sensitive adhesive raised pavement markers white lens, 100 per carton	10	\$205.00	\$ 2,050.00
Faces: Two way pressure sensitive adhesive raised pavement markers yellow lens, 100 per carton	10	\$205.00	\$ 2,050.00
Protective overlay film (series 1160), 30" x 50 yards	10	\$517.50	\$ 5,175.00
Protective overlay film (series 1160), 36" x 50 yards	10	\$621.00	\$ 6,210.00
Total Section 7:			\$ 320,491.34

Vendor Name:

Section 8: Cutting Knives	Estimated Annual Quantity	Bid Price per Each	Extended Cost
CB09UA-5 cutting knives for Western Graphtec cutting pro 300-100	25		\$ -
CB15U-5 cutting knives for Western Graphtec cutting pro 300-100	25		\$ -
Total Section 8:			\$ -

**NO BID
THIS PAGE**

Section 9: Banding Materials	Estimated Annual Quantity	Bid Price per Each	Extended Cost
Stainless steel, 3/4" x 100' x .030 coil in dispensing box, type 201 universal	3		\$ -
3/4" wide stainless steel top split wing seal	100		\$ -
Flared leg stainless sign bracket with bolt & washer	100		\$ -
Total Section 9:			\$ -

Vendor Name:

Section 10: Safety Vests	Estimated Annual Quantity	Bid Price per Each	Extended Cost
Safetey vests, ML Kishigo Ultra-Cool mesh, contrasting #1056 (or equal), ANSI/ISEA 107 2010 Class 2 compliant, zipper front closure, 2" wide reflective material with 4.5" contrasting color, inside left chest 2-tier 4-division pencil pocket, lower right inside patch pocket, with Mic Tab on front left chest, with Road and Bridge imprinted on back, Size: M	100		\$ -
Safetey vests, ML Kishigo Ultra-Cool mesh, contrasting #1056 (or equal), ANSI/ISEA 107 2010 Class 2 compliant, zipper front closure, 2" wide reflective material with 4.5" contrasting color, inside left chest 2-tier 4-division pencil pocket, lower right inside patch pocket, with Mic Tab on front left chest, with Road and Bridge imprinted on back, Size: L	100		\$ -
Safetey vests, ML Kishigo Ultra-Cool mesh, contrasting #1056 (or equal), ANSI/ISEA 107 2010 Class 2 compliant, zipper front closure, 2" wide reflective material with 4.5" contrasting color, inside left chest 2-tier 4-division pencil pocket, lower right inside patch pocket, with Mic Tab on front left chest, with Road and Bridge imprinted on back, Size: XL	100		\$ -
Safetey vests, ML Kishigo Ultra-Cool mesh, contrasting #1056 (or equal), ANSI/ISEA 107 2010 Class 2 compliant, zipper front closure, 2" wide reflective material with 4.5" contrasting color, inside left chest 2-tier 4-division pencil pocket, lower right inside patch pocket, with Mic Tab on front left chest, with Road and Bridge imprinted on back, Size: XXL	100		\$ -
Safetey vests, ML Kishigo Ultra-Cool mesh, contrasting #1056 (or equal), ANSI/ISEA 107 2010 Class 2 compliant, zipper front closure, 2" wide reflective material with 4.5" contrasting color, inside left chest 2-tier 4-division pencil pocket, lower right inside patch pocket, with Mic Tab on front left chest, with Road and Bridge imprinted on back, Size: XXXL	100		\$ -

Vendor Name:

Section 10: Safety Vests (cont'd)	Estimated Annual Quantity	Bid Price per Each	Extended Cost
Safetey vests, ML Kishigo Ultra-Cool mesh, contrasting #1056 (or equal), ANSI/ISEA 107 2010 Class 2 compliant, zipper front closure, 2" wide reflective material with 4.5" contrasting color, inside left chest 2-tier 4-division pencil pocket, lower right inside patch pocket, with Mic Tab on front left chest, with Road and Bridge imprinted on back, Size: 4XL	100		\$ -
Safetey vests, ML Kishigo Ultra-Cool mesh, contrasting #1056 (or equal), ANSI/ISEA 107 2010 Class 2 compliant, zipper front closure, 2" wide reflective material with 4.5" contrasting color, inside left chest 2-tier 4-division pencil pocket, lower right inside patch pocket, with Mic Tab on front left chest, with Road and Bridge imprinted on back, Size: 5XL	100		\$ -
Total Section 10:			\$ -

Vendor Name:

Section 11: Stop/Slow Paddles	Estimated Annual Quantity	Bid Price per Each	Extended Cost
Stop/slow paddles, 24" aluminum, Diamond Grade reflective with 12" handle	10		\$ -
Extension handles, telescopic with 2 height settings for 6' and 7' height	10		\$ -
Total Section 11:			\$ -

Section 12: Miscellaneous	Estimated Annual Quantity	Bid Price per Each	Extended Cost
Yellow water base traffic paint for stripping roads in	1100		\$ -
White water base traffic paint for stripping roads in	1100		\$ -
Blue water base traffic paint for stripping roads in gallons	1100		\$ -
Red water base traffic paint for stripping roads in gallons	1100		\$ -
Black water base traffic paint for stripping roads in gallons	1100		\$ -
Glass beads, in pounds, 50 pounds per bag	1000		\$ -
Bitumem adhesive for raised pavement markings in	5000		\$ -
Total Section 12:			\$ -

CERTIFICATE OF INTERESTED PARTIES

FORM 1295

1 of 1

Complete Nos. 1 - 4 and 6 if there are interested parties.
Complete Nos. 1, 2, 3, 5, and 6 if there are no interested parties.

**OFFICE USE ONLY
CERTIFICATION OF FILING**

Certificate Number:
2021-705799

Date Filed:
01/13/2021

Date Acknowledged:
03/23/2021

1 Name of business entity filing form, and the city, state and country of the business entity's place of business.
Core Products, LLC.
Covington, LA United States

2 Name of governmental entity or state agency that is a party to the contract for which the form is being filed.
Fort Bend County

3 Provide the identification number used by the governmental entity or state agency to track or identify the contract, and provide a description of the services, goods, or other property to be provided under the contract.
B21-048
Traffic Signs, Posts, Supplies

4	Name of Interested Party	City, State, Country (place of business)	Nature of interest (check applicable)	
			Controlling	Intermediary

5 Check only if there is NO Interested Party.

6 UNSWORN DECLARATION

My name is _____, and my date of birth is _____.

My address is _____, _____, _____, _____, _____.
(street) (city) (state) (zip code) (country)

I declare under penalty of perjury that the foregoing is true and correct.

Executed in _____ County, State of _____, on the _____ day of _____, 20____.
(month) (year)

Signature of authorized agent of contracting business entity
(Declarant)

CERTIFICATE OF INTERESTED PARTIES

FORM 1295

1 of 1

Complete Nos. 1 - 4 and 6 if there are interested parties.
 Complete Nos. 1, 2, 3, 5, and 6 if there are no interested parties.

**OFFICE USE ONLY
 CERTIFICATION OF FILING**

Certificate Number:
 2021-727066

Date Filed:
 03/15/2021

Date Acknowledged:
 03/23/2021

1 Name of business entity filing form, and the city, state and country of the business entity's place of business.
 Dobie Supply, LLC.
 Austin, TX United States

2 Name of governmental entity or state agency that is a party to the contract for which the form is being filed.
 Fort Bend County

3 Provide the identification number used by the governmental entity or state agency to track or identify the contract, and provide a description of the services, goods, or other property to be provided under the contract.
 B21-048
 Traffic Signs, Posts, Supplies.

4	Name of Interested Party	City, State, Country (place of business)	Nature of interest (check applicable)	
			Controlling	Intermediary

5 Check only if there is NO Interested Party.

6 UNSWORN DECLARATION

My name is _____, and my date of birth is _____.

My address is _____, _____, _____, _____, _____.
(street) (city) (state) (zip code) (country)

I declare under penalty of perjury that the foregoing is true and correct.

Executed in _____ County, State of _____, on the _____ day of _____, 20____.
(month) (year)

 Signature of authorized agent of contracting business entity
 (Declarant)

CERTIFICATE OF INTERESTED PARTIES

FORM 1295

1 of 1

Complete Nos. 1 - 4 and 6 if there are interested parties.
 Complete Nos. 1, 2, 3, 5, and 6 if there are no interested parties.

**OFFICE USE ONLY
 CERTIFICATION OF FILING**

Certificate Number:
 2021-729125

Date Filed:
 03/22/2021

Date Acknowledged:
 03/23/2021

1 Name of business entity filing form, and the city, state and country of the business entity's place of business.
 Newman Traffic Signs
 Jamestown, ND United States

2 Name of governmental entity or state agency that is a party to the contract for which the form is being filed.
 Fort Bend County

3 Provide the identification number used by the governmental entity or state agency to track or identify the contract, and provide a description of the services, goods, or other property to be provided under the contract.
 45-0276348
 Traffic signs, posts, brackets, sheeting, etc.

4	Name of Interested Party	City, State, Country (place of business)	Nature of interest (check applicable)	
			Controlling	Intermediary

5 Check only if there is NO Interested Party.

6 UNSWORN DECLARATION

My name is _____, and my date of birth is _____.

My address is _____, _____, _____, _____, _____.
(street) (city) (state) (zip code) (country)

I declare under penalty of perjury that the foregoing is true and correct.

Executed in _____ County, State of _____, on the _____ day of _____, 20____.
(month) (year)

 Signature of authorized agent of contracting business entity
 (Declarant)

CERTIFICATE OF INTERESTED PARTIES

FORM 1295

1 of 1

Complete Nos. 1 - 4 and 6 if there are interested parties.
Complete Nos. 1, 2, 3, 5, and 6 if there are no interested parties.

**OFFICE USE ONLY
CERTIFICATION OF FILING**

Certificate Number:
2021-727034

Date Filed:
03/15/2021

Date Acknowledged:
03/23/2021

1 Name of business entity filing form, and the city, state and country of the business entity's place of business.
Osburn Associates, Inc.
Logan, OH United States

2 Name of governmental entity or state agency that is a party to the contract for which the form is being filed.
Fort Bend County

3 Provide the identification number used by the governmental entity or state agency to track or identify the contract, and provide a description of the services, goods, or other property to be provided under the contract.
B21-048
Traffic Signs, Posts, Supplies

4	Name of Interested Party	City, State, Country (place of business)	Nature of interest (check applicable)	
			Controlling	Intermediary

5 Check only if there is NO Interested Party.

6 UNSWORN DECLARATION

My name is _____, and my date of birth is _____.

My address is _____, _____, _____, _____, _____.
(street) (city) (state) (zip code) (country)

I declare under penalty of perjury that the foregoing is true and correct.

Executed in _____ County, State of _____, on the _____ day of _____, 20____.
(month) (year)

Signature of authorized agent of contracting business entity
(Declarant)

CERTIFICATE OF INTERESTED PARTIES

FORM 1295

1 of 1

Complete Nos. 1 - 4 and 6 if there are interested parties.
 Complete Nos. 1, 2, 3, 5, and 6 if there are no interested parties.

**OFFICE USE ONLY
 CERTIFICATION OF FILING**

1 Name of business entity filing form, and the city, state and country of the business entity's place of business.
 Trantex Transportation Products of Texas Inc.
 HOUSTON, TX United States

Certificate Number:
 2021-702799

Date Filed:
 01/05/2021

2 Name of governmental entity or state agency that is a party to the contract for which the form is being filed.
 Fort Bend County

Date Acknowledged:
 03/23/2021

3 Provide the identification number used by the governmental entity or state agency to track or identify the contract, and provide a description of the services, goods, or other property to be provided under the contract.
 B21-048
 Traffic Signs, Posts, Supplies

4	Name of Interested Party	City, State, Country (place of business)	Nature of interest (check applicable)	
			Controlling	Intermediary

5 Check only if there is NO Interested Party.

6 UNSWORN DECLARATION

My name is _____, and my date of birth is _____.

My address is _____, _____, _____, _____, _____.
(street) (city) (state) (zip code) (country)

I declare under penalty of perjury that the foregoing is true and correct.

Executed in _____ County, State of _____, on the _____ day of _____, 20____.
(month) (year)

 Signature of authorized agent of contracting business entity
 (Declarant)

CERTIFICATE OF INTERESTED PARTIES

FORM 1295

1 of 1

Complete Nos. 1 - 4 and 6 if there are interested parties.
 Complete Nos. 1, 2, 3, 5, and 6 if there are no interested parties.

**OFFICE USE ONLY
 CERTIFICATION OF FILING**

Certificate Number:
 2021-727085

Date Filed:
 03/15/2021

Date Acknowledged:
 03/23/2021

1 Name of business entity filing form, and the city, state and country of the business entity's place of business.
 Vulcan Inc., dba Vulcan Aluminum, dba Vulcan Signs
 Foley, AL United States

2 Name of governmental entity or state agency that is a party to the contract for which the form is being filed.
 Fort Bend County

3 Provide the identification number used by the governmental entity or state agency to track or identify the contract, and provide a description of the services, goods, or other property to be provided under the contract.
 B21-048
 Traffic Signs, Posts, Supplies

4	Name of Interested Party	City, State, Country (place of business)	Nature of interest (check applicable)	
			Controlling	Intermediary

5 Check only if there is NO Interested Party.

6 UNSWORN DECLARATION

My name is _____, and my date of birth is _____.

My address is _____, _____, _____, _____, _____.
(street) (city) (state) (zip code) (country)

I declare under penalty of perjury that the foregoing is true and correct.

Executed in _____ County, State of _____, on the _____ day of _____, 20____.
(month) (year)

 Signature of authorized agent of contracting business entity
 (Declarant)