

Fort Bend County Tabulation

Bid 21-046

Purchase of Ammunition

Term: April 1, 2021 through March 31, 2022

Recommendation: low bidder per item

Description (no substitute)	Lawson Number	Rounds per Box	Bid Price per Box	Rounds per Case	Bid Price per Case	Number of Delivery Days	Rounds per Box	Bid Price per Box	Rounds per Case	Bid Price per Case	Number of Delivery Days												
												Vendor											
												Precision Delta Corporation						TXAT LLC					
9.1: .223 HORNADY TAP 80265 75 GR. Manufacturer: HORNADY No Sub	12945		No Bid		No Bid			No Bid		No Bid													
9.2: .223 HORNADY TAP 83278 55 GR. FPD Manufacturer: HORNADY No Sub			No Bid		No Bid			No Bid		No Bid													
9.3: .223 REM, L223R3 55 GR. MC Manufacturer: REMINGTON No Sub	12946		No Bid		No Bid			No Bid		No Bid													
9.4: 9-MM Luger L9MM3 115 GR. MC Manufacturer: REMINGTON No Sub	12947		No Bid		No Bid			No Bid		No Bid													
9.5: 9-MM Luger L9MM2, 23718, 124 GR. FMJ Manufacturer: REMINGTON No Sub			No Bid		No Bid			No Bid		No Bid													
9.6: 9-MM Golden Saber GS9MMB 124 GR. Manufacturer: REMINGTON No Sub	12948		No Bid		No Bid			No Bid		No Bid													

Description (no substitute)	Lawson Number	Rounds per Box	Bid Price per Box	Rounds per Case	Bid Price per Case	Number of Delivery Days	Rounds per Box	Bid Price per Box	Rounds per Case	Bid Price per Case	Number of Delivery Days
		Precision Delta Corporation					TXAT LLC				
9.7: 9-MM Luger TP, 29351, GSB9MMD 124 Manufacturer: REMINGTON No Sub			No Bid		No Bid			No Bid		No Bid	
9.8: .40 S & W L40SW3 180 GR. MC Manufacturer: REMINGTON No Sub	12949		No Bid		No Bid			No Bid		No Bid	
9.9: .40 Golden Saber GS40SWB 180 GR. Manufacturer: REMINGTON No Sub	12950		No Bid		No Bid			No Bid		No Bid	
9.10: .357 SIG GSB357SB Golden Saber 357 SIG 125GR BJHP Manufacturer: REMINGTON No Sub	12951		No Bid		No Bid			No Bid		No Bid	
9.11: .357 SIG L357S1 UMC 125GR MC Manufacturer: REMINGTON No Sub	12952		No Bid		No Bid			No Bid		No Bid	
9.12: 38 SPL L38S11 130 GR. MC Manufacturer: REMINGTON No Sub	12953		No Bid		No Bid			No Bid		No Bid	
9.13: 38 SPL L38S11 158 GR., LRN, L3855, Manufacturer: REMINGTON No Sub			No Bid		No Bid			No Bid		No Bid	
9.14: 45 Auto L45AP4 UMC 45 ACP 230GR. MC Manufacturer: REMINGTON No Sub	12954		No Bid		No Bid			No Bid		No Bid	

Description (no substitute)	Lawson Number	Rounds per Box	Bid Price per Box	Rounds per Case	Bid Price per Case	Number of Delivery Days	Rounds per Box	Bid Price per Box	Rounds per Case	Bid Price per Case	Number of Delivery Days
		Precision Delta Corporation					TXAT LLC				
9.15: 45 Auto GS45APB Manufacturer: REMINGTON No Sub	12955		No Bid		No Bid			No Bid		No Bid	
9.16: 12 GA. RR12BK8- 00 2 3/4" Buckshot 8 pellets reduced recoil Manufacturer: REMINGTON No Sub	12956		No Bid		No Bid			No Bid		No Bid	
9.17: 308 win. #80965, 168GR, A-MAX Tap Manufacturer: HORNADY No Sub			No Bid		No Bid			No Bid		No Bid	
9.18: 308 win. #80715, 168GR, ELD Tap AR Manufacturer: HORNADY No Sub			No Bid		No Bid			No Bid		No Bid	
9.19: 12 GA. RR12RSB 12 GA 2 3/4" Foster slug reduced recoil Manufacturer: REMINGTON No Sub	12957		No Bid		No Bid			No Bid		No Bid	

Description (no substitute)	Lawson Number	Rounds per Box	Bid Price per Box	Rounds per Case	Bid Price per Case	Number of Delivery Days	Rounds per Box	Bid Price per Box	Rounds per Case	Bid Price per Case	Number of Delivery Days
		Precision Delta Corporation					TXAT LLC				
9.20: 12 GA. GC127 2 3/4" 7 1/2 target loads Manufacturer: REMINGTON No Sub	12959		No Bid		No Bid			No Bid		No Bid	
9.21: R30301 Core-Lokt, 30-30 win. 150 gr. SPCL. Manufacturer: REMINGTON No Sub	12960		No Bid		No Bid			No Bid		No Bid	
9.22: Blank Popper, Winchester 12 GA. 2 3/4" smokeless power Manufacturer: WINCHESTER XP12	12961	25	NA	250	\$ 112.00	180 +		No Bid		No Bid	

Description	Lawson Number	Rounds per Box	Bid Price per Box	Rounds per Case	Bid Price per Case	Number of Delivery Days	Precision Delta Corporation		TXAT LLC		
							Rounds per Box	Bid Price per Box	Rounds per Case	Bid Price per Case	Number of Delivery Days
9.23: .223 HORNADY TAP 80265 75 GR. HORNADY or Equal Winchester RA556M	12962	20	NA	1000	\$750.00	180+		No Bid		No Bid	
9.24: .223 HORNADY TAP 83278 55 GR. FPD HORNADY or Equal Winchester RA223BSTAY	12963	20	NA	1000	\$725.00	90-180		No Bid		No Bid	
9.25: .223 REM, L223R3 55 GR. MC REMINGTON or Equal AGUILA 1E223110	12964	20	NA	100	\$330.00	90-120	50	\$ 17.52	1000	\$ 350.40	60
9.26: 9-MM Luger L9MM3 115 GR. MC REMINGTON or Equal Winchester Q4172	12965	50	NA	5000	\$96.00	180-270	50	\$ 9.87	1000	\$ 197.40	60
9.27: 9-MM Golden Saber GS9MMB 124 GR. BJHP REMINGTON or Equal Winchester RA9BA	12966	50	NA	500	\$177.50	90-180		No Bid		No Bid	
9.28: .40 S & W L40SW3 180 GR. MC REMINGTON or Equal Winchester Q4238	12967	50	NA	500	\$113.00	90-180	50	\$ 13.73	1000	\$ 274.60	60
9.29: .40 Golden Saber GS40SWB 180 GR. REMINGTON or Equal Winchester RA40B	12968	50	NA	500	\$187.00	90-180		No Bid		No Bid	

Description	Lawson Number	Rounds per Box	Bid Price per Box	Rounds per Case	Bid Price per Case	Number of Delivery Days	Precision Delta Corporation		TXAT LLC		
							Rounds per Box	Bid Price per Box	Rounds per Case	Bid Price per Case	Number of Delivery Days
9.30: .357 SIG GSB357SB Golden Saber 357 SIG 125GR BJHP REMINGTON or Equal Winchester RA357SB	12969	50	NA	500	\$ 250.00	180 +		No Bid		No Bid	
9.31: .357 SIG L357S1 UMC 125GR MC REMINGTON or Equal Winchester Q4309	12970	50	NA	500	\$ 175.00	180 +		No Bid		No Bid	
9.32: 38 SPL L38S11 130 GR. MC REMINGTON or Equal Winchester Q4171	12971	50	NA	500	\$ 117.00	180 +	50	\$ 15.26	1000	\$ 305.20	60
9.33: 45 Auto L45AP4 UMC 45 ACP 230GR. MC REMINGTON or Equal Winchester Q4170	12972	50	NA	500	\$ 129.00	180 +	50	\$ 15.36	1000	\$ 307.20	60
9.34: 45 Auto GS45APB REMINGTON or Equal Winchester RA45B	12973	50	NA	500	\$ 220.00	120-180		No Bid		No Bid	
9.35: 12 GA. RR12BK8-00 2 3/4" Buckshot 8 pellets reduced recoil REMINGTON or Equal Winchester RA120085	12974	5	NA	250	\$ 114.00	120-180		No Bid		No Bid	
9.36: 12 GA. RR12RSB 12 GA 2 3/4" Foster slug reduced recoil REMINGTON or Equal Winchester RA12RS15	12975	5	NA	250	\$ 125.00	120-180		No Bid		No Bid	

Description	Lawson Number	Bid Price per Round	Bid Price per Box	Rounds per Case	Bid Price per Case	Number of Delivery Days	Bid Price per Round	Bid Price per Box	Bid Price per Case	Rounds per Case	Number of Delivery Days
9.37: 12 GA. GC127 2 3/4" 7 1/2 target loads REMINGTON or Equal	12976	25	NA	25	\$ 62.00	120-180	\$ 0.20600	\$ 5.16	\$ 51.60	250	60
AGUILA 1CHB1357											
9.38: R30301 Core-Lokt, 30-30 win. 150 gr. SPCL. REMINGTON or Equal	12977	20	NA	20	\$ 198.00	120-180				No Bid	
Winchester X30306BP											
9.39: Blank Popper, Winchester 12 GA. 2 3/4" smokeless power REMINGTON or Equal	12978	25	NA	25	\$ 112.00	180+				No Bid	
Winchester XP12											



**COUNTY PURCHASING AGENT
Fort Bend County, Texas**

Vendor Information

Jaime Kovar
County Purchasing Agent

Office (281) 341-8640

Legal Company Name (top line of W9)	Precision Delta Corporation		
Business Name (if different from legal name)			
Federal ID # or S.S. #	640671844	DUNS #	130443302
Type of Business	<input checked="" type="checkbox"/> Corporation/LLC <input type="checkbox"/> Sole Proprietor/Individual	<input type="checkbox"/> Partnership <input type="checkbox"/> Tax Exempt Organization	Age in Business?
Publicly Traded Business	<input checked="" type="checkbox"/> No <input type="checkbox"/> Yes Ticker Symbol _____		
Remittance Address	PO Box 128		
City/State/Zip	Ruleville MS 38771		
Physical Address	205 W Floyce St		
City/State/Zip	Ruleville MS 38771		
Phone/Fax Number	Phone: 662 756 2810 Fax: 662 756 2590		
Contact Person	Patricia Lott		
E-mail	precdelta@tecinfo.net		
Check all that apply to the company listed above and provide certification number.	DBE-Disadvantaged Business Enterprise _____	Certification # _____	
	SBE-Small Business Enterprise _____	Certification # _____	
	HUB -Texas Historically Underutilized Business _____	Certification # _____	
	WBE-Women's Business Enterprise _____	Certification # _____	
Company's gross annual receipts	<\$500,000 _____	\$500,000-\$4,999,999 _____	
	\$5,000,000-\$16,999,999 <input checked="" type="checkbox"/>	\$17,000,000-\$22,399,999 _____	
	>\$22,400,000 _____		
NAICs codes (Please enter all that apply)	332992		
Signature of Authorized Representative	Patricia Lott		
Printed Name	Patricia Lott		
Title	Vice President		
Date	1-12-21		

THIS FORM MUST BE SUBMITTED WITH THE SOLICITATION RESPONSE

**Fort Bend County, Texas
Invitation for Bid**



**Term Contract for Purchase of Ammunition
BID 21-046**

SUBMIT BIDS TO:

Fort Bend County
Purchasing Department
Travis Annex
301 Jackson, Suite 201
Richmond, TX 77469

Note: All correspondence must include the term
“Purchasing Department” in address to assist in
proper delivery.

SUBMIT NO LATER THAN:

Tuesday, January 19, 2021
2:00 PM (Central)

LABEL ENVELOPE:

BID 21-046
AMMUNITION

***ALL BIDS MUST BE RECEIVED IN AND TIME/DATE STAMPED BY THE PURCHASING OFFICE
OF FORT BEND COUNTY BEFORE THE SPECIFIED TIME/DATE STATED ABOVE.
BIDS RECEIVED AS REQUIRED WILL THEN BE OPENED AND PUBLICLY READ.
BIDS RECEIVED AFTER THE SPECIFIED TIME, WILL BE RETURNED UNOPENED.***

Results will not be given by phone.
Results will be provided to bidder in writing
after the Commissioners Court awards.

Requests for information must be in
writing and directed to:
Cheryl Krejci, CPPB
Senior Buyer
cheryl.krejci@fortbendcountytexas.gov

Vendor Responsibilities:

- Download and complete any addendums. (Addendums will be posted on the Fort Bend County website no later than 48 hours prior to bid opening)
- Submit response in accordance with requirements stated on the cover of this document.
- DO NOT submit responses via email or fax.

COUNTY PURCHASING AGENT

Fort Bend County, Texas



Jaime Kovar
County Purchasing Agent

(281) 341-8640
Fax (281) 341-8645

January 5, 2021

TO: All Prospective Bidders

RE: Addendum No.1 – Fort Bend County BID 21-046 – Ammunition

Addendum 1:

Vendors are to download the amended Pricing Form and provide with their solicitation response. Estimated usage quantities have been added for some items.

Immediately upon your receipt of this addendum, please fill out the following information and email this page to Jessica Carabajal at jessica.carabajal@fortbendcountytexas.gov

Precision Delta Corporation

Company Name

Patricia Lott

Signature of person receiving addendum

1-6-2021

Date

If you have any questions, please contact this office.

Sincerely,

Cheryl Krejci

Cheryl Krejci
Senior Buyer

1.0 GENERAL REQUIREMENTS:

- 1.1 Read this entire document carefully. Follow all instructions. You are responsible for fulfilling all requirements and specifications. Be sure you understand them.
- 1.2 General Requirements apply to all advertised bids, however, these may be superseded, whole or in part, by the scope, special requirements, specifications, special specifications or other data contained herein.
- 1.3 Governing Law: Bidder is advised that these requirements shall be fully governed by the laws of the State of Texas and that Fort Bend County may request and rely on advice, decisions and opinions of the Attorney General of Texas and the County Attorney concerning any portion of these requirements.
- 1.4 Bid Document Completion: Fill out, initial each page, sign, and return ONE (1) complete bid document to the Fort Bend County Purchasing Department. An authorized representative of the bidder must sign the Contract Sheet. Do not complete the date at the top of the contract sheet. The bid document must be in a sealed envelope marked with the appropriate bid number and title. The contract will be binding only when signed by the County Judge, Fort Bend County and a purchase order authorizing the item(s) desired has been issued. The use of correction fluid is not acceptable and may result in the disqualification of bid. If an error is made, the bidder must draw a line through error and initial each change. All response, typed or written, information must be clear and legible.



If a pricing form in Excel is included and posted on the County's website amongst this bid document, the Vendor must download, complete and save the Excel (not a PDF of the Excel file) file of the pricing form on a CD or flash drive. The Excel file on the CD or flash drive must be downloadable by the Purchasing Department in order to copy and paste the vendor's pricing to the County's tabulation. The CD or flash drive must be labeled and included in the same sealed envelope with the respondent's completed bid document along with a printed copy of the pricing form completed by the vendor.

- 1.5 Bid Returns: Bidders must return completed bid document to the Fort Bend County Purchasing Department at 301 Jackson, Suite 201, Richmond, Texas no later than 2:00 P.M. on the date specified. Late bids will not be accepted. Bids must be submitted in a sealed envelope, addressed as follows: Fort Bend County Purchasing Agent, Travis Annex, 301 Jackson, Suite 201, Richmond, Texas 77469.
- 1.6 Governing Document: In the event of any conflict between the terms and provisions of these requirements and the specifications, the specifications shall govern. In the event of any conflict of interpretation of any part of this overall document, Fort Bend County's interpretation shall govern.

Initials of Bidder: _____

Handwritten initials 'pl' in blue ink are written over the line for the bidder's initials.

- 1.7 Addenda: No interpretation of the meaning of the drawings, specifications or other bid documents will be made to any bidder orally. All requests for such interpretations must be made in writing addressed to Ms. Cheryl Krejci, Senior Buyer, 301 Jackson, Suite 201, Richmond, Texas 77469, e-mail: cheryl.krejci@fortbendcountytexas.gov. Any and all interpretations and any supplemental instructions will be in the form of written addenda to the contract documents which will be posted on Fort Bend County's website. Addenda will **ONLY** be issued by the Fort Bend County Purchasing Agent. It is the sole responsibility of each bidder to insure receipt of any and all addenda. All addenda issued will become part of the contract documents. Bidders must sign and include addendum in the returned bid package. Deadline for submission of questions and/or clarification is **Tuesday, January 12, 2021 at 9:00 AM (CST)**. Requests received after the deadline will not be responded to due to the time constraints of this bid process.
- 1.8 Hold Harmless Agreement: Contractor shall indemnify and hold Fort Bend County harmless from all claims for personal injury, death and/or property damage arising from any cause whatsoever, resulting directly or indirectly from contractor's performance. Contractor shall procure and maintain, with respect to the subject matter of this bid, appropriate insurance coverage including, as a minimum, public liability and property damage with adequate limits to cover contractor's liability as may arise directly or indirectly from work performed under terms of this bid. Certification of such coverage must be provided to the County upon request.
- 1.9 Waiver of Subrogation: Bidder and bidder's insurance carrier waive any and all rights whatsoever with regard to subrogation against Fort Bend County as an indirect party to any suit arising out of personal or property damages resulting from bidder's performance under this agreement.
- 1.10 Severability: If any section, subsection, paragraph, sentence, clause, phrase or word of these requirements or the specifications shall be held invalid, such holding shall not affect the remaining portions of these requirements and the specifications and it is hereby declared that such remaining portions would have been included in these requirements and the specifications as though the invalid portion had been omitted.
- 1.11 Bonds: If this bid requires submission of bid guarantee and performance bond, there will be a separate page explaining those requirements. Bids submitted without the required bid bond or cashier's checks are not acceptable. Bond/s or cashier's check must be complete with all required signatures.
- 1.12 Taxes: Fort Bend County is exempt from all federal excise, state and local taxes unless otherwise stated in this document. Fort Bend County claims exemption from all sales and/or use taxes under Chapter 20, Title 122a, Vernon's Texas Civil Statutes, as amended. Texas Limited Sales Tax Exemption Certificates will be furnished upon written request to the Fort Bend County Purchasing Department.

Initials of Bidder: _____

pl

- 1.13 Fiscal Funding: A multi-year lease or lease/purchase arrangement (if requested by the specifications), or any contract continuing as a result of an extension option, must include fiscal funding out. If, for any reason, funds are not appropriated to continue the lease or contract, said lease or contract shall become null and void. After expiration of the lease, leased equipment shall be removed by the bidder from the using department without penalty of any kind or form to Fort Bend County. All charges and physical activity related to delivery, installation, removal and redelivery shall be the responsibility of the bidder.
- 1.14 Pricing: Prices for all goods and/or services shall be firm for the duration of this contract and shall be stated in the bid spreadsheet. Prices shall be all inclusive. No price changes, additions, or subsequent qualifications will be honored during the course of the contract. All prices must be written in ink or typewritten. Pricing on all transportation, freight, and other charges are to be prepaid by the contractor and included in the bid prices. If there are any additional charges of any kind, other than those mentioned above, specified or unspecified, bidder MUST indicate the items required and attendant costs or forfeit the right to payment for such items.
- 1.15 Silence of Specifications: The apparent silence of specifications as to any detail, or the apparent omission from it of a detailed description concerning any point, shall be regarded as meaning that only the best commercial practice is to prevail and that only material and workmanship of the finest quality are to be used. All interpretations of specifications shall be made on the basis of this statement. The items furnished under this contract shall be new, unused of the latest product in production to commercial trade and shall be of the highest quality as to materials used and workmanship. Manufacturer furnishing these items shall be experienced in design and construction of such items and shall be an established supplier of the item bid.
- 1.16 Supplemental Materials: Bidders are responsible for including all pertinent product data in the returned bid package. Literature, brochures, data sheets, specification information, completed forms requested as part of the bid package and any other facts which may affect the evaluation and subsequent contract award should be included. Materials such as legal documents and contractual agreements, which the bidder wishes to include as a condition of the bid, must also be in the returned bid package. Failure to include all necessary and proper supplemental materials may be cause to reject the entire bid.
- 1.17 Material Safety Data Sheets: Under the "Hazardous Communication Act", commonly known as the "Texas Right To Know Act", a bidder must provide to County and using departments, with each delivery, material safety data sheets, which are, applicable to hazardous substances defined in the Act. Bidders are obligated to maintain a current, updated file in the Fort Bend County Purchasing Department. Failure of the bidder to maintain such a file will be cause to reject any bid applying thereto.

Initials of Bidder: _____



- 1.18 Name Brands: Specifications may reference name brands and model numbers. It is not the intent of Fort Bend County to restrict these bids in such cases, but to establish a desired quality level of merchandise or to meet a pre-established standard due to like existing items. Bidders may offer items of equal stature and the burden of proof of such stature rests with them. Fort Bend County shall act as sole judge in determining equality and acceptability of products offered.
- 1.19 Color Selection: Determination of colors of materials is a right reserved by the using department unless otherwise specified in the bid. Unspecified colors shall be quoted as standard colors, not colors, which require up charges or special handling. Unspecified fabrics or vinyl should be construed as medium grade. If bidder fails to get color/material approvals prior to delivery of merchandise, the using department may refuse to accept the items and demand correct shipment without penalty, subject to other legal remedies.
- 1.20 Evaluation: Evaluation shall be used as a determinant as to which bid items or services are the most efficient and/or most economical for the County. It shall be based on all factors, which have a bearing on price and performance of the items in the user environment. All bids are subject to tabulation by the Fort Bend County Purchasing Department and recommendation to Fort Bend County Commissioners Court. Compliance with all bid requirements, delivery and needs of the using department are considerations in evaluating bids. Pricing is NOT the only criteria for making a recommendation. The Fort Bend County Purchasing Department reserves the right to contact any bidder, at any time, to clarify, verify or request information with regard to any bid.
- 1.21 Inspections: Fort Bend County reserves the right to inspect any item(s) or service location for compliance with specifications and requirements and needs of the using department. If a bidder cannot furnish a sample of a bid item, where applicable, for review, or fails to satisfactorily show an ability to perform, the County can reject the bid as inadequate.
- 1.22 Testing: Fort Bend County reserves the right to test equipment, supplies, material and goods bid for quality, compliance with specifications and ability to meet the needs of the user. Demonstration units must be available for review. Should the goods or services fail to meet requirements and/or be unavailable for evaluation, the bid is subject to rejection.
- 1.23 Disqualification of Bidder: Upon signing this bid document, a bidder offering to sell supplies, materials, services, or equipment to Fort Bend County certifies that the bidder has not violated the antitrust laws of this state codified in section 15.01, et seq., Business & Commerce Code, or the federal antitrust laws, and has not communicated directly or indirectly the bid made to any competitor or any other person engaged in such line of business. Any or all bids may be rejected if the County believes that collusion exists among the bidders. Bids in which the prices are

Initials of Bidder: _____



provide services without a Fort Bend County Purchase Order, signed by an authorized agent of the Fort Bend County Purchasing Department. The fastest, most reasonable delivery time shall be indicated by the bidder in the proper place on the bid sheet. Any special information concerning delivery should also be included, on a separate sheet, if necessary. All items shall be shipped F.O.B. inside delivery unless otherwise stated in the specifications. This shall be understood to include bringing merchandise to the appropriate room or place designated by the using department. Every tender or delivery of goods must fully comply with all provisions of these requirements and the specifications including time, delivery and quality. Nonconformance shall constitute a breach, which must be rectified prior to expiration of the time for performance. Failure to rectify within the performance period will be considered cause to reject future deliveries and cancellation of the contract by Fort Bend County without prejudice to other remedies provided by law. Where delivery times are critical, Fort Bend County reserves the right to award accordingly.

- 1.31 Contract Extension: Extensions may be made only by written agreement between Fort Bend County and the bidder. Any price escalations are limited to those stated by the bidder in the original bid.
- 1.32 Termination: Fort Bend County reserves the right to terminate the contract for default if Seller breaches any of the terms therein, including warranties of bidder or if the bidder becomes insolvent or commits acts of bankruptcy. Such right of termination is in addition to and not in lieu of any other remedies, which Fort Bend County may have in law or equity. Default may be construed as, but not limited to, failure to deliver the proper goods and/or services within the proper amount of time, and/or to properly perform any and all services required to Fort Bend County's satisfaction and/or to meet all other obligations and requirements. Contracts may be terminated without cause upon thirty (30) days written notice to either party unless otherwise specified.
- 1.33 Recycled Materials: Fort Bend County encourages the use of products made of recycled materials and shall give preference in purchasing to products made of recycled materials if the products meet applicable specifications as to quantity and quality. Fort Bend County will be the sole judge in determining product preference application.
- 1.34 Interlocal Participation: Additional governmental entities may purchase from this bid. Vendor agrees to accept purchase orders from those participating entities and to invoice each entity separately.
- 1.35 Escalation Clause: Successful bidder may apply for a price increase to the Fort Bend County Purchasing Agent. The County Purchasing Agent will review, and, if increase is deemed warranted, place the request on Fort Bend County's Commissioners Court agenda for their action of approval or disapproval. Approval by the County's Commissioner's Court is required. Any proposed price increase will

Initials of Bidder: _____



only be the amount increased to the vendor from his/her supplier. The price increase request must be stated on the vendor's letterhead with the bid number and name in the subject including, in columns, for each item: item description, original bid price, percent of increase, and the total cost of the original bid price including the increased dollar amount. Written documentation from the vendor's supplier of the increase notice must be provided to the Purchasing Agent at time of increase request. No application for a price increase may be submitted within the first six (6) months of this contract. Increase requests of more than 25% of the original bid price will not be considered.

- 1.36 Modifications: This instrument contains the entire Contract between the parties relating to the rights herein granted and obligations herein assumed. Any oral or written representations or modifications concerning this instrument shall be of no force and effect excepting a subsequent written modification signed by both parties hereto.

2.0 TERMS & CONDITIONS:

- 2.1 Seller to Package Goods: Seller will package goods in accordance with good commercial practice. Each delivery container shall be clearly and permanently marked as follows (a) Seller's name and address; (b) Consignee's name, address and purchase order number and the bid number if applicable; (c) Container number and total number of containers (e.g. box 1 of 4 boxes); and (d) the number of the container bearing the packing slip. Seller shall bear cost of packaging unless otherwise provided. Goods shall be suitably packed to secure lowest transportation costs and to conform to requirements of common carriers and any applicable specifications. Fort Bend County's count or weight shall be final and conclusive on shipments not accompanied by packing list.
- 2.2 Shipment Under Reservation Prohibited: Seller is not authorized to ship goods under reservation and no tender of a bill of lading will operate as a tender of goods.
- 2.3 Title and Risk of Loss: The title and risk of loss of the goods shall not pass to the County until a County employee actually receives and takes possession of the goods at the point or points of delivery.
- 2.4 Delivery Terms: F.O.B. Destination Freight Prepaid, Inside Delivery, unless delivery terms are specified otherwise on Purchase Order.
- 2.5 No Replacement of Defective Tender: Every tender or delivery of goods must fully comply with all provisions of the Purchase Order as to time of delivery, quality and the like. If a tender is made which does not fully conform, this shall constitute a breach and Seller shall not have the right to substitute a conforming tender.
- 2.6 Place of Delivery: The place of delivery shall be that set forth in the block of the

Initials of Bidder: _____



purchase order entitled "Ship To". Any change thereto shall be effective by modification as provided for in Clause number 2.20 "Modifications", hereof. The terms of this agreement are "no arrival, no sale", at the discretion of Fort Bend County.

2.7 Invoices and Payments:

2.7.1 Seller shall submit separate invoices, in duplicate. Invoices shall indicate the purchase order number and the bid number if applicable. Invoices shall be itemized and transportation charges, if any, shall be listed separately. A copy of the bill of lading, and the freight waybill when applicable should be attached to the invoice.

2.7.2 Fort Bend County's obligation is payable only and solely from funds available for the purpose of this purchase. Lack of funds shall render the order null and void to the extent funds are not available and any delivered but unpaid goods will be returned to Seller by the county.

2.7.3 Do not include Federal Excise, State, or City Sales Tax. Fort Bend County is a tax-exempt governmental entity.

2.8 Gratuities: Fort Bend County may, by written notice to the Seller, cancel any order without liability, if it is determined by the County that gratuities, in the form of entertainment, gifts, or otherwise were offered or given by the Seller, or any agent or representative of the Seller to any officer or employee of Fort Bend County with a view toward securing an order. In the event an order is canceled by the County pursuant to this provision, the County shall be entitled, in addition to any other rights and remedies, to recover or withhold the amount of the cost incurred by Seller in providing such gratuities.

2.9 Special Tools and Test Equipment: If the price stated on the face of an order includes the cost of any special tooling or special test equipment fabricated or required by Seller for the purpose of filing this order, such special tooling equipment and any process sheets related thereto shall become the property of the County and to the extent feasible shall be identified by the Seller as such.

2.10 Warranty/Price:

2.10.1 The price to be paid by the County shall be that contained in Seller's bid which Seller warrants to be no higher than Seller's current prices on orders by others for products of the kind and specification covered by an order for similar quantities under similar or like conditions and methods of purchase. In the event Seller breaches this warranty the prices of the items shall be reduced to the Seller's current prices on orders by others. Fort Bend County may cancel this contract without liability.

Initials of Bidder: _____



- 2.10.2 The Seller warrants that no person or selling agency has been employed or retained to solicit or secure any County order based upon any agreement or understanding for commission, percentage, brokerage, or contingent fee excepting bona fide employees of bona fide established commercial or selling agencies maintained by the Seller for the purpose of securing business. A breach or violation of this warranty gives the County the right, in addition to any other right or rights, to cancel this contract without liability.
- 2.11 Warranty Product: Seller shall not limit or exclude any implied warranties and any attempt to do so shall render an order voidable at the option of the County. Seller warrants that the goods furnished will conform to the specifications, drawings, and description listed in the bid invitation and purchase order as applicable, and to the sample(s) furnished by Seller if any. In the event of a conflict between the specifications, drawings, and descriptions, the specifications shall govern.
- 2.12 Safety Warranty: Seller warrants that the product sold to Fort Bend County shall conform to the standards promulgated by the U.S. Department of Labor under the Occupational Safety and Health Act of 1970. In the event the product does not conform to OSHA standards, the County may return the product for correction or replacement at the Seller's expense. In the event Seller fails to make the appropriate correction within 10 days, correction made by the County will be at Seller's expense.
- 2.13 No Warranty by Fort Bend County Against Infringements: As part of a contract for sale Seller agrees to ascertain whether goods manufactured in accordance with the specifications will give rise to the rightful claim of any third person by way of infringement. Fort Bend County makes no warranty that the production of goods according to the specification will not give rise to such a claim and in no event shall Fort Bend County be liable to Seller for indemnification in the event the Seller is sued on the grounds of infringement or the like. If Seller is of the opinion that an infringement will result, he will notify Fort Bend County to this effect in writing within two days after the receiving Purchase Order. If the County does not receive notice and is subsequently held liable for the infringement, Seller will defend and save the County harmless. If Seller in good faith ascertains that production of the goods in accordance with the specifications will result in infringement, this contract shall be null and void except that the County will pay Seller the reasonable cost of his search as to infringements.
- 2.14 Right of Inspection: The County shall have the right to inspect the goods at delivery before accepting them.
- 2.15 Cancellation: Fort Bend County shall have the right to cancel for default all or any part of the undelivered portion of an order if Seller breaches any of the terms hereof including warranties of Seller, or if the Seller becomes insolvent or files for protection under the bankruptcy laws. Such rights of cancellation are in addition to and not in lieu of any other remedies, which Fort Bend County may have in law or

Initials of Bidder: _____



equity.

- 2.16 Termination: The performance of work under a Purchase Order may be terminated in whole or in part by the County in accordance with this provision. Termination of work there under shall be effected by the delivery to the Seller of a "Notice of Termination" specifying the extent to which performance of work under the order is terminated and the date upon which such termination becomes effective. Such right of termination is in addition to and not in lieu of rights of Fort Bend County set forth in Clause 15 herein.
- 2.17 Force Majeure: Force Majeure means a delay encountered by a party in the performance of its obligations under this Agreement, which is caused by an event beyond the reasonable control of that party. Without limiting the generality of the foregoing, "Force Majeure" shall include but not be restricted to the following types of events: acts of God or public enemy; acts of governmental or regulatory authorities; fires, floods, epidemics or serious accidents; unusually severe weather conditions; strikes, lockouts, or other labor disputes; and defaults by subcontractors.
- In the event of a Force Majeure, the affected party shall not be deemed to have violated its obligations under this Agreement, and the time for performance of any obligations of that party shall be extended by a period of time necessary to overcome the effects of the Force Majeure, provided that the foregoing shall not prevent this Agreement from terminating in accordance with the termination provisions. If any event constituting a Force Majeure occurs, the affected party shall notify the other parties in writing, within twenty-four (24) hours, and disclose the estimated length of delay, and cause of the delay.
- 2.18 Assignment-Delegation: No right or interest in an order shall be assigned or delegation of any obligation made by Seller without the written permission of Fort Bend County. Any attempted assignment or delegation by Seller shall be wholly void and totally ineffective for all purposes unless made in conformity with this paragraph.
- 2.19 Waiver: No claim or right arising out of a breach of any contract can be discharged in whole or in part by a waiver or renunciation of the claim or right unless the waived or renunciation is supported by consideration and is in writing signed by the aggrieved party.
- 2.20 Modification: A Purchase Order can be modified or rescinded only by a writing signed by both of the parties or their duly authorized agents.
- 2.21 Parol Evidence: This writing is intended by the parties as a final expression of their agreement and is intended also as a complete and exclusive statement of the terms of this agreement. No course of prior dealings between the parties and no usage of the trade shall be relevant to supplement or explain any terms rendered under this agreement and shall not be relevant to determine the meaning of this agreement even

Initials of Bidder: _____

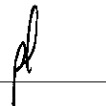

though the accepting or acquiescing party has knowledge of the performance and opportunity for objection. Whenever a term defined by the Uniform Commercial Code is used in this agreement, the definition contained in the Code is to control.

- 2.22 Applicable Law: This agreement shall be governed by the Uniform Commercial Code. Whenever the term "Uniform Commercial Code" is used it shall be construed as meaning the Uniform Commercial Code as adopted in the State of Texas and in effective on the date of the purchase order.
- 2.23 Advertising: Seller shall not advertise or publish, without the County's prior consent the fact that Fort Bend County has entered into any contract, except to the extent necessary to comply with proper requests for information from an authorized representative of the federal, state, or local government.
- 2.24 Right to Assurance: Whenever the County in good faith has reason to question the other party's intent to perform. The County may demand that the other party give written assurance of his intent to perform. In the event that a demand is made and no assurance is given within five (5) days, the County may treat this failure as an anticipatory repudiation of the contract.
- 2.25 Venue: Both parties agree that venue for any litigation arising from this contract shall lie in Richmond, Fort Bend County, Texas.
- 2.26 Prohibition Against Personal Interest in Contracts: No officer or employee of the County shall have a financial interest, direct or indirect, in any contract with the County, or shall be financially interested, directly or indirectly, in the sale to the County of any land, materials, supplies, or service, except on behalf of the County as an officer or employee. Any willful violation of this section shall constitute malfeasance in office, and any officer or employee guilty thereof shall be subject to disciplinary action under applicable laws, statutes and codes of the State of Texas. Any violation of this section, with the knowledge, expressed or implied of the person or corporation contracting with the County shall render the contract involved voidable by the County Commissioners Court.

3.0 SCOPE:

It is the intent of Fort Bend County to contract with one (1) or more vendors to supply ammunition, which meets or exceeds the specifications contained herein.

4.0 TERM OF CONTRACT:

The term of this contract **April 1, 2021 through March 31, 2022, renewable annually for two (2) years (through March 31, 2024) under the same terms and conditions if mutually agreeable by both parties.** Either party for any reason may terminate this contract by giving thirty (30) days written notice of the intent to terminate.

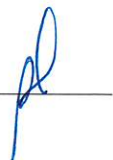

5.0 TEXAS ETHICS COMMISSION FORM 1295:

- 5.1 Effective January 1, 2016 all contracts executed by Commissioners Court, regardless of the dollar amount, will require completion of Form 1295 "Certificate of Interested Parties", per the new Government Code Statute §2252.908. All vendors submitting a response to a formal Bid, RFP, SOQ or any contracts, contract amendments, renewals or change orders are required to complete the Form 1295 online through the State of Texas Ethics Commission website. Please visit: https://www.ethics.state.tx.us/whatsnew/elf_info_form1295.htm.
- 5.2 On-line instructions:
- 5.2.1 Name of governmental entity is to read: Fort Bend County.
- 5.2.2 Identification number used by the governmental entity is: B21-046.
- 5.2.3 Description is the title of the solicitation: Ammunition.
- 5.3 Apparent low bidder(s) will be required to provide the Form 1295 within three (3) calendar days from notification; however, if your company is publicly traded you are not required to complete this form.

6.0 STATE LAW REQUIREMENTS FOR CONTRACTS:

The contents of this section are required by Texas Law and are included by County regardless of content.

- 6.1 Agreement to Not Boycott Israel Chapter 2270 Texas Government Code: By signature on vendor form, Contractor verifies Contractor does not boycott Israel and will not boycott Israel during the term of this Contract.
- 6.2 Texas Government Code Section 2251.152 Acknowledgment: By signature on vendor form, Contractor represents pursuant to Section 2252.152 of the Texas Government Code, that Contractor is not listed on the website of the Comptroller of the State of Texas concerning the listing of companies that are identified under Section 806.051, Section 807.051 or Section 2253.153.

7.0 HUMAN TRAFFICKING:

By acceptance of this contract, Contractor acknowledges that Fort Bend County is opposed to human trafficking and that no County funds will be used in support of services or activities that violate human trafficking laws.

Initials of Bidder: _____



Specifications are located in the Excel pricing forms downloadable from Fort Bend County's website. Provide bid prices in the electronic Excel file and return as stated in Section 1.4 and 1.5. Items 9.1 through 9.17 are to bid providing the specified Manufacture and Number. Items 9.18 through 9.39 are to be bid as specified or include the manufacture's name and number of the equal to item in the cell below the specified. See Name Brand Clause 1.18. All ammunition must be new and delivered in the original manufacturer's packaging. Minimum orders are not permitted.

10.0 DELIVERY:

Delivery of all items ordered must be completed within one hundred twenty (120) calendar days, unless otherwise noted, after receipt of purchase order issued by the Fort Bend County Purchasing Agent. If order cannot be fulfilled within this time frame, vendor is required to inform Fort Bend County Purchasing. Delivery must be made to the department listed on the purchase order.

11.0 AWARD:

This contract will be awarded to the low bidder meeting specifications per item.

12.0 REQUIRED FORMS:

All vendors submitting are required to complete and provide with submission along with any other documentation as stated herein:

- 12.1 Vendor Form
- 12.2 W9 Form
- 12.3 Tax Form/Debt/Residence Certification



Contract Sheet
Bid 21-046

THE STATE OF TEXAS
COUNTY OF FORT BEND

This memorandum of agreement made and entered into on the 9th day of February, 2021
by and between Fort Bend County in the State of Texas (hereinafter designated County), acting herein by
County Judge KP George, by virtue of an order of Fort Bend County Commissioners Court, and
Precision Delta Corporation (hereinafter designated Contractor).
(company name)

WITNESSETH:

The Contractor and the County agree that the bid and specifications for the Purchase of Ammunition which
are hereto attached and made a part hereof, together with this instrument and the bond (when required) shall
constitute the full agreement and contract between parties and for furnishing the items set out and described;
the County agrees to pay the prices stipulated in the accepted bid.

It is further agreed that this contract shall not become binding or effective until signed by the parties hereto
and a purchase order authorizing the items desired has been issued.

Executed at Richmond, Texas this 9 day of February 2021

KP George
By: County Judge KP George
Fort Bend County, Texas
County Judge, KP George

Patricia Lott
By: Signature of Contractor

Patricia Lott, Vice President
By: Printed Name and Title

Request for Taxpayer Identification Number and Certification

**Give Form to the
 requester. Do not
 send to the IRS.**

Print or type
 See Specific Instructions on page 2.

1 Name (as shown on your income tax return). Name is required on this line; do not leave this line blank. Precision Delta Corporation	
2 Business name/disregarded entity name, if different from above	
3 Check appropriate box for federal tax classification; check only one of the following seven boxes: <input type="checkbox"/> Individual/sole proprietor or single-member LLC <input checked="" type="checkbox"/> C Corporation <input type="checkbox"/> S Corporation <input type="checkbox"/> Partnership <input type="checkbox"/> Trust/estate <input type="checkbox"/> Limited liability company. Enter the tax classification (C=C corporation, S=S corporation, P=partnership) ▶ _____ Note. For a single-member LLC that is disregarded, do not check LLC; check the appropriate box in the line above for the tax classification of the single-member owner. <input type="checkbox"/> Other (see instructions) ▶ _____	4 Exemptions (codes apply only to certain entities, not individuals; see instructions on page 3): Exempt payee code (if any) _____ Exemption from FATCA reporting code (if any) _____ <i>(Applies to accounts maintained outside the U.S.)</i>
5 Address (number, street, and apt. or suite no.) Po Box 128 205 W Floyco St	Requester's name and address (optional)
6 City, state, and ZIP code Ruleville Ms 38771	
7 List account number(s) here (optional)	

Part I Taxpayer Identification Number (TIN)

Enter your TIN in the appropriate box. The TIN provided must match the name given on line 1 to avoid backup withholding. For individuals, this is generally your social security number (SSN). However, for a resident alien, sole proprietor, or disregarded entity, see the Part I instructions on page 3. For other entities, it is your employer identification number (EIN). If you do not have a number, see *How to get a TIN* on page 3.

Note. If the account is in more than one name, see the instructions for line 1 and the chart on page 4 for guidelines on whose number to enter.

Social security number [] [] [] - [] [] [] - [] [] [] []
or
Employer identification number 64 - 0671844

Part II Certification

Under penalties of perjury, I certify that:

1. The number shown on this form is my correct taxpayer identification number (or I am waiting for a number to be issued to me); and
2. I am not subject to backup withholding because: (a) I am exempt from backup withholding, or (b) I have not been notified by the Internal Revenue Service (IRS) that I am subject to backup withholding as a result of a failure to report all interest or dividends, or (c) the IRS has notified me that I am no longer subject to backup withholding; and
3. I am a U.S. citizen or other U.S. person (defined below); and
4. The FATCA code(s) entered on this form (if any) indicating that I am exempt from FATCA reporting is correct.

Certification instructions. You must cross out item 2 above if you have been notified by the IRS that you are currently subject to backup withholding because you have failed to report all interest and dividends on your tax return. For real estate transactions, item 2 does not apply. For mortgage interest paid, acquisition or abandonment of secured property, cancellation of debt, contributions to an individual retirement arrangement (IRA), and generally, payments other than interest and dividends, you are not required to sign the certification, but you must provide your correct TIN. See the instructions on page 3.

Sign Here	Signature of U.S. person ▶ Patricia Lott	Date ▶ 1-12-21
------------------	--	--

General Instructions

Section references are to the Internal Revenue Code unless otherwise noted.

Future developments. Information about developments affecting Form W-9 (such as legislation enacted after we release it) is at www.irs.gov/fw9.

Purpose of Form

An individual or entity (Form W-9 requester) who is required to file an information return with the IRS must obtain your correct taxpayer identification number (TIN) which may be your social security number (SSN), individual taxpayer identification number (ITIN), adoption taxpayer identification number (ATIN), or employer identification number (EIN), to report on an information return the amount paid to you, or other amount reportable on an information return. Examples of information returns include, but are not limited to, the following:

- Form 1099-INT (interest earned or paid)
- Form 1099-DIV (dividends, including those from stocks or mutual funds)
- Form 1099-MISC (various types of income, prizes, awards, or gross proceeds)
- Form 1099-B (stock or mutual fund sales and certain other transactions by brokers)
- Form 1099-S (proceeds from real estate transactions)
- Form 1099-K (merchant card and third party network transactions)

- Form 1098 (home mortgage interest), 1098-E (student loan interest), 1098-T (tuition)
- Form 1099-C (canceled debt)
- Form 1099-A (acquisition or abandonment of secured property)

Use Form W-9 only if you are a U.S. person (including a resident alien), to provide your correct TIN.

If you do not return Form W-9 to the requester with a TIN, you might be subject to backup withholding. See What is backup withholding? on page 2.

By signing the filled-out form, you:

1. Certify that the TIN you are giving is correct (or you are waiting for a number to be issued),
2. Certify that you are not subject to backup withholding, or
3. Claim exemption from backup withholding if you are a U.S. exempt payee. If applicable, you are also certifying that as a U.S. person, your allocable share of any partnership income from a U.S. trade or business is not subject to the withholding tax on foreign partners' share of effectively connected income, and
4. Certify that FATCA code(s) entered on this form (if any) indicating that you are exempt from the FATCA reporting, is correct. See *What is FATCA reporting?* on page 2 for further information.

Job No.: B21-046

TAX FORM/DEBT/ RESIDENCE CERTIFICATION
(for Advertised Projects)

Taxpayer Identification Number (T.I.N.): 64-0671844

Company Name submitting Bid/Proposal: Precision Delta Corporation

Mailing Address: Po Box 128 Ruleville Ms 38771

Are you registered to do business in the State of Texas? Yes No

If you are an individual, list the names and addresses of any partnership of which you are a general partner or any assumed name(s) under which you operate your business

I. **Property:** List all taxable property in Fort Bend County owned by you or above partnerships as well as any d/b/a names. Include real and personal property as well as mineral interest accounts. (Use a second sheet of paper if necessary.)

<u>Fort Bend County Tax Acct. No.*</u>	<u>Property address or location**</u>
<u>None</u>	

* This is the property account identification number assigned by the Fort Bend County Appraisal District.
 ** For real property, specify the property address or legal description. For business personal property, specify the address where the property is located. For example, office equipment will normally be at your office, but inventory may be stored at a warehouse or other location.

II. **Fort Bend County Debt** - Do you owe any debts to Fort Bend County (taxes on properties listed in I above, tickets, fines, tolls, court judgments, etc.)?
 Yes No If yes, attach a separate page explaining the debt.

III. **Residence Certification** - Pursuant to Texas Government Code §2252.001 *et seq.*, as amended, Fort Bend County requests Residence Certification. §2252.001 *et seq.* of the Government Code provides some restrictions on the awarding of governmental contracts; pertinent provisions of §2252.001 are stated below:

- (3) "Nonresident bidder" refers to a person who is not a resident.
- (4) "Resident bidder" refers to a person whose principal place of business is in this state, including a contractor whose ultimate parent company or majority owner has its principal place of business in this state.

I certify that _____ is a Resident Bidder of Texas as defined in Government Code §2252.001.
 [Company Name]

I certify that Precision Delta Corporation is a Nonresident Bidder as defined in Government Code §2252.001 and our principal place of business is Ruleville Ms.
 [Company Name] [City and State]

Amended 1/05/21
Fort Bend County Pricing Form
Bid 21-046
Purchase of Ammunition

Term: April 1, 2021 through March 31, 2022

Vendor Name:		Precision Delta Corporation					
Description (no substitute)	Lawson Number	Rounds per Box	Bid Price per Box	Rounds per Case	Bid Price per Case	Number of Delivery Days	Number of Cases Purchased in 2020 Budget Year
(only 4 decimal places are permitted)							
9.1: .223 HORNADY TAP 80265 75 GR. Manufacturer: HORNADY No Sub	12945		No Bid - No Sub Allowed		No Bid - No Sub Allowed		NA
9.2: .223 HORNADY TAP 83278 55 GR. FPD Manufacturer: HORNADY No Sub			No Bid - No Sub Allowed		No Bid - No Sub Allowed		NA
9.3: .223 REM, L223R3 55 GR. MC Manufacturer: REMINGTON No Sub	12946		No Bid - No Sub Allowed		No Bid - No Sub Allowed		500
9.4: 9-MM Luger L9MM3 115 GR. MC Manufacturer: REMINGTON No Sub	12947		No Bid - No Sub Allowed		No Bid - No Sub Allowed		165
9.5: 9-MM Luger L9MM2, 23718, 124 GR. FMJ Manufacturer: REMINGTON No Sub			No Bid - No Sub Allowed		No Bid - No Sub Allowed		NA
9.6: 9-MM Golden Saber GS9MMB 124 GR. Manufacturer: REMINGTON No Sub	12948		No Bid - No Sub Allowed		No Bid - No Sub Allowed		51

Vendor Name:

Precision Delta Corporation

Description (no substitute)	Lawson Number	Rounds per Box	Bid Price per Box	Rounds per Case	Bid Price per Case	Number of Delivery Days	Number of Cases Purchased in 2020 Budget Year
		(only 4 decimal places are permitted)					
9.7: 9-MM Luger TP, 29351, GSB9MMD 124 Manufacturer: REMINGTON No Sub			No Bid - No Sub Allowed		No Bid - No Sub Allowed		NA
9.8: .40 S & W L40SW3 180 GR. MC Manufacturer: REMINGTON No Sub	12949		No Bid - No Sub Allowed		No Bid - No Sub Allowed		3
9.9: .40 Golden Saber GS40SWB 180 GR. Manufacturer: REMINGTON No Sub	12950		No Bid - No Sub Allowed		No Bid - No Sub Allowed		1
9.10: .357 SIG GSB357SB Golden Saber 357 SIG 125GR BJHP Manufacturer: REMINGTON No Sub	12951		No Bid - No Sub Allowed		No Bid - No Sub Allowed		1
9.11: .357 SIG L357S1 UMC 125GR MC Manufacturer: REMINGTON No Sub	12952		No Bid - No Sub Allowed		No Bid - No Sub Allowed		1
9.12: 38 SPL L38S11 130 GR. MC Manufacturer: REMINGTON No Sub	12953		No Bid - No Sub Allowed		No Bid - No Sub Allowed		20
9.13: 38 SPL L38S11 158 GR., LRN, L3855, Manufacturer: REMINGTON No Sub			No Bid - No Sub Allowed		No Bid - No Sub Allowed		NA
9.14: 45 Auto L45AP4 UMC 45 ACP 230GR. MC Manufacturer: REMINGTON No Sub	12954		No Bid - No Sub Allowed		No Bid - No Sub Allowed		1

Vendor Name:

Precision Delta Corporation

Description (no substitute)	Lawson Number	Rounds per Box	Bid Price per Box	Rounds per Case	Bid Price per Case	Number of Delivery Days	Number of Cases Purchased in 2020 Budget Year
		(only 4 decimal places are permitted)					
9.15: 45 Auto GS45APB Manufacturer: REMINGTON No Sub	12955		No Bid - No Sub Allowed		No Bid - No Sub Allowed		1
9.16: 12 GA. RR12BK8- 00 2 3/4" Buckshot 8 pellets reduced recoil Manufacturer: REMINGTON No Sub	12956		No Bid - No Sub Allowed		No Bid - No Sub Allowed		NA
9.17: 308 win. #80965, 168GR, A-MAX Tap Manufacturer: HORNADY No Sub			No Bid - No Sub Allowed		No Bid - No Sub Allowed		NA
9.18: 308 win. #80715, 168GR, ELD Tap AR Manufacturer: HORNADY No Sub			No Bid - No Sub Allowed		No Bid - No Sub Allowed		NA
9.19: 12 GA. RR12RSB 12 GA 2 3/4" Foster slug reduced recoil Manufacturer: REMINGTON No Sub	12957		No Bid - No Sub Allowed		No Bid - No Sub Allowed		NA

Vendor Name:

Precision Delta Corporation

Description (no substitute)	Lawson Number	Rounds per Box	Bid Price per Box	Rounds per Case	Bid Price per Case	Number of Delivery Days	Number of Cases Purchased in 2020 Budget Year
		(only 4 decimal places are permitted)					
9.20: 12 GA. GC127 2 3/4" 7 1/2 target loads Manufacturer: REMINGTON No Sub	12959		No Bid - No Sub Allowed		No Bid - No Sub Allowed		NA
9.21: R30301 Core-Lokt, 30-30 win. 150 gr. SPCL. Manufacturer: REMINGTON No Sub	12960		No Bid - No Sub Allowed		No Bid - No Sub Allowed		NA
9.22: Blank Popper, Winchester 12 GA. 2 3/4" smokeless power Manufacturer: WINCHESTER No Sub	12961	Wincheste r XP12 25 RDS/BOX	Must be ordered by the Case	Wincheste r XP12 250 RDS/Case	112	180 + days	NA

Vendor Name:

Precision Delta Corporation

Description	Lawson Number	Rounds per Box	Bid Price per Box	Rounds per Case	Bid Price per Case	Number of Delivery Days	Number of Cases Purchased in 2020 Budget Year
9.23: .223 HORNADY TAP 80265 75 GR. HORNADY or Equal	12962	Winchester RA556M 20 rds/Box	Must be ordered by the Case	Winchester RA556M 1000 rds/Case	750	180+	NA
9.24: .223 HORNADY TAP 83278 55 GR. FPD HORNADY or Equal	12963	Winchester RA223BS TAY 20	Must be ordered by the Case	Winchester RA223BS TAY 1000	725	90-180	NA
9.25: .223 REM, L223R3 55 GR. MC REMINGTON or Equal	12964	Winchester USA223R 1KY 20	Must be ordered by the Case	Winchester USA223R 1KY 100	330	90-120	NA
9.26: 9-MM Luger L9MM3 115 GR. MC REMINGTON or Equal	12965	Winchester Q4172 50 rd/box	Must be ordered by the Case	Winchester Q4172 5000 rd/case	96	180-270	NA
9.27: 9-MM Golden Saber GS9MMB 124 GR. BJHP REMINGTON or Equal	12966	Winchester RA9BA 50 rd/box	Must be ordered by the Case	Winchester RA9BA 500 rd/Case	178	90-180	NA
9.28: .40 S & W L40SW3 180 GR. MC REMINGTON or Equal	12967	Winchester Q4238 50 rd/box	Must be ordered by the Case	Winchester Q4238 500 rd/Case	113	90-180	NA
9.29: .40 Golden Saber GS40SWB 180 GR. REMINGTON or Equal	12968	Winchester RA40B 50 rd/box	Must be ordered by the Case	Winchester RA40B 500 rd/Case	187	90-180	NA

Vendor Name:

Precision Delta Corporation

Description	Lawson Number	Rounds per Box	Bid Price per Box	Rounds per Case	Bid Price per Case	Number of Delivery Days	Number of Cases Purchased in 2020 Budget Year
(only 4 decimal places are permitted)							
9.30: .357 SIG GSB357SB Golden Saber 357 SIG 125GR BJHP REMINGTON or Equal	12969	Winchester RA357SB 50 rd/box	Must be ordered by the Case	Winchester RA357SB 500 rd/case	250	180 + days	NA
9.31: .357 SIG L357S1 UMC 125GR MC REMINGTON or Equal	12970	Winchester Q4309 50 rd/box	Must be ordered by the Case	Winchester Q4309 500	175	180 + days	NA
9.32: 38 SPL L38S11 130 GR. MC REMINGTON or Equal	12971	Winchester Q4171 50 rd/box	Must be ordered by the Case	Winchester Q4171 500	117	180 + days	NA
9.33: 45 Auto L45AP4 UMC 45 ACP 230GR. MC REMINGTON or Equal	12972	Winchester Q4170 50 rd/box	Must be ordered by the Case	Winchester Q4170 500 rd/cse	129	180 + days	NA
9.34: 45 Auto GS45APB REMINGTON or Equal	12973	Winchester RA45B 50 rd/box	Must be ordered by the Case	Winchester RA45B 500	220	120-180 days	NA
9.35: 12 GA. RR12BK8-00 2 3/4" Buckshot 8 pellets reduced recoil REMINGTON or Equal	12974	Winchester RA120085 5 rd/box	Must be ordered by the Case	Winchester RA120085 250 rd/case	114	120-180+ days	NA
9.36: 12 GA. RR12RSB 12 GA 2 3/4" Foster slug reduced recoil REMINGTON or Equal	12975	Winchester RA12RS1 5 5	Must be ordered by the Case	Winchester RA12RS1 5 250	125	120-180 days	NA

Vendor Name:		Precision Delta Corporation					
Description	Lawson Number	Bid Price per Round	Bid Price per Box	Bid Price per Case	Rounds per Case	Number of Delivery Days	Number of Cases Purchased in 2020 Budget Year
(only 4 decimal places are permitted)							
9.37: 12 GA. GC127 2 3/4" 7 1/2 target loads REMINGTON or Equal	12976	Winchester TRGT127 25 rd/box	Must be ordered by the Case	\$ 62.00	Winchester TRGT127 250	120-180 days	NA
9.38: R30301 Core-Lokt, 30-30 win. 150 gr. SPCL. REMINGTON or Equal	12977	Winchester X30306BP 20 rd/box	Must be ordered by the Case	\$ 198.00	Winchester X30306BP 200	120-180+ days	NA
9.39: Blank Popper, Winchester 12 GA. 2 3/4" smokeless power REMINGTON or Equal	12978	Winchester XP12 25 rd/box	Must be ordered by the Case	\$ 112.00	Winchester XP12 250 rd/Case	180+ days	NA



12 Gauge, 2.75"

[WHERE TO BUY](#)

SUPER X

XP12 \$

★★★★★ 4.2 (9) [Write a review](#) [Ask a question](#)

Since 1922, Super-X ammunition has provided exceptional quality and outstanding performance for all types of hunters and shooters who rely on its time-proven dependability backed by legendary excellence.

BRAND: Super X

ROUNDS PER BOX: 25

ROUNDS PER CASE: 250



[Features](#) [Ballistics](#) [Gallery](#)

Clean Burning Smokeless Blank

Realistic sound

Great Training Load





HANDGUN

RIFLE

SHOTSHELL

PRODUCT RESOURCES ▾

📍 FIND DIS

Home / Rifle / Ranger / RA556M



5.56mm, 77 Grain



RANGER

RA556M \$\$\$

Winchester Ranger offers a proven lineup of duty and training ammunition products; trusted reliability by the law enforcement community for decades.

USAGE:

BRAND: [Ranger](#)

ROUNDS PER BOX: 20

ROUNDS PER CASE: 1000



Ballistics Gallery

Convert Units US ▾

DISTANCE (YARDS)	VELOCITY (FPS)	ENERGY (FT-LBS)	TRAJ SHORT RANGE (IN)
muzzle	2935	1224	-0.8
50	2658	1001	
100	2411	826	0

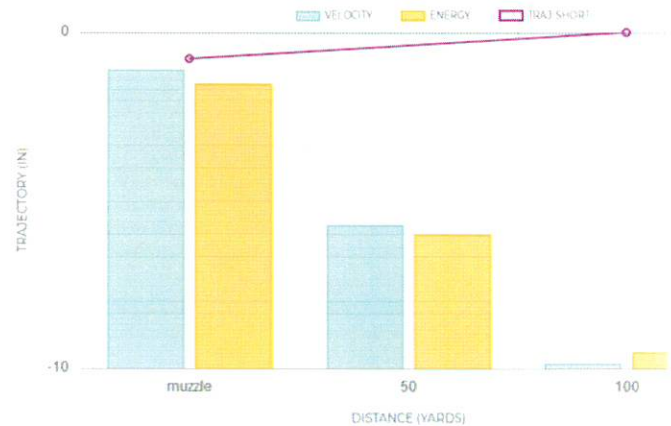



Winchester Ranger 223 Rem (55) BST

- Symbol: **RA223BSTA-Y** – Winchester Ranger Ballistic Silvertip
- Shellcase: 223 Rem nickel plated brass shellcase
- Bullet: 55 grain (3.6 gram) Ballistic Silvertip
Winchester Lubalox Black Oxide Coated Bullet
Diameter .224 inch (5.69 mm)
- Powder: Clean burning, low flash
- Primer: Winchester non-corrosive primer - boxer type
- Accuracy: Product Mean of 1.00 inch (2.54 cm) Extreme Spread
10 shot targets at 100 yards (91.4 m) from a 24 inch (61 cm) SAAMI test barrel
- Velocity: 3240 ft/sec (988 m/s) nominal at 15 ft (4.6 m)
Fired in a 24 inch (61 cm) standard SAAMI test barrel
- Energy: 1282 ft-lb (1738 joules)
- Pressure: 55,000 psi max. average (3,792 bars)
- Waterproofing: None

NOMINAL DIMENSIONS SHOWN

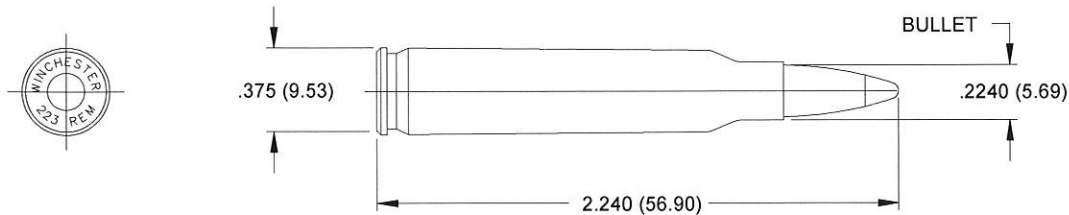

RA223BSTA

REF: W1585

INFORMATION PUBLISHED HEREIN IS SUBJECT TO CHANGE AT MANUFACTURER'S DISCRETION WITHOUT NOTICE.

PRODUCT INFORMATION SHEET #184
Rev. 5-16-2003

OLIN CORPORATION • WINCHESTER DIVISION • 427 NORTH SHAMROCK STREET • EAST ALTON, IL 62024-1197
TELEPHONE: 618 258-2000 • WEB SITE: www.winchester.com



Winchester 223 Rem (55) FMJ

- Symbol: **USA223R1KY**– Winchester USA Brand
- Shellcase: 223 Rem brass shellcase
- Bullet: 55 grain (3.56 gram) Full Metal Jacket Boat Tail
Brass jacket, lead core
Diameter .2240 inch (5.69 mm)
- Powder: Clean burning, low flash
- Primer: Winchester non-corrosive primer - boxer type
- Accuracy: Product Mean of 1.85 inches (4.7 cm) Extreme Spread
5-shot targets at 100 yards (91.4 m) from a 24 inch (61.0 cm) SAAMI test barrel
- Velocity: 3215 ft/sec (980 m/s) nominal at 15 ft (4.6 m)
Fired in a 24 inch (61.0 cm) standard SAAMI test barrel
- Energy: 1262 ft-lb (1711 joules)
- Pressure: 55,000 psi max. average (3793 bars)
- Waterproofing: None

NOMINAL DIMENSIONS SHOWN

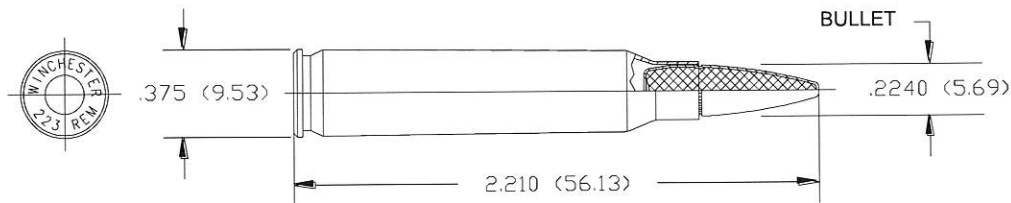

USA223R1

REF. WI442

INFORMATION PUBLISHED HEREIN IS SUBJECT TO CHANGE AT MANUFACTURER'S DISCRETION WITHOUT NOTICE.

PRODUCT INFORMATION SHEET #158

Rev. 08-06-2002

OLIN CORPORATION • WINCHESTER DIVISION • 427 NORTH SHAMROCK STREET • EAST ALTON, IL 62024-1197
TELEPHONE: 618 258-2000 • WEB SITE: www.winchester.com



Winchester 9mm Luger (115) FMJ Paramilitary

- Symbol: **Q4172** – Winchester 9mm Luger (115) Full Metal Jacket Paramilitary
- Shellcase: 9mm Luger brass shellcase
- Bullet: 115 grain (7.5 gram) Full Metal Jacket
Brass jacket, lead core
Diameter .3545 inch (9.00 mm)
- Powder: Clean burning, low flash
- Primer: Winchester non-corrosive, boxer type
- Accuracy: Product Mean of 4.25 inches (10.8 cm) Extreme Spread
5 shot targets at 50 yards (45.7 m) from a 4 inch (10.2 cm) SAAMI test barrel
- Velocity: 1180 ft/sec (360 m/s) nominal at 15 ft (4.6 m)
Fired in a 4 inch (10.2 cm) SAAMI test barrel
- Energy: 355 ft-lb (481 joules)
- Pressure: 35,000 psi max. average (2,414 bars)
- Waterproofing: None

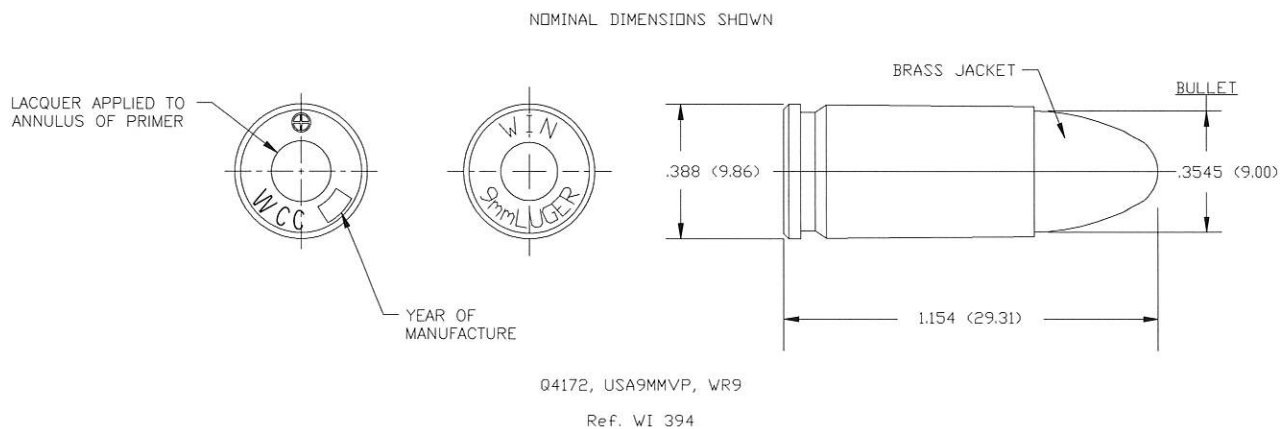

INFORMATION PUBLISHED HEREIN IS SUBJECT TO CHANGE AT MANUFACTURER'S DISCRETION WITHOUT NOTICE.
4-27-2011, ECO 32009



Winchester 9mm Luger +P (124) Bonded JHP

- Symbol: **RA9BA** – Winchester Ranger Bonded
- Shellcase: 9mm Luger +P nickel plated brass shellcase with cap lacquer and mouth lacquer
- Bullet: 124 grain (8.0 gram) Bonded JHP; Bullet Jacket Bonded to Lead Core
Diameter .355 inch (9.02 mm)
- Powder: Clean burning, low flash
- Primer: Winchester non-corrosive primer, boxer type
- Accuracy: Product Mean of 2.0 inches (5.1 cm) Extreme Spread
5 shot targets at 50 yards (45.7 m) from a 4 inch (10.2 cm) SAAMI test barrel
- Velocity: 1180 ft/sec (360 m/s) nominal at 15 ft (4.6 m)
Fired in a 4 inch (10.2 cm) standard SAAMI test barrel
- Energy: 383 ft-lb (519 joules)
Fired in a 4 inch (10.2 cm) standard SAAMI test barrel
- Pressure: 38,000 psi max. average (2621 bars)
- Waterproofing: Lacquer applied to primer annulus and Black Lucas applied to mouth of case

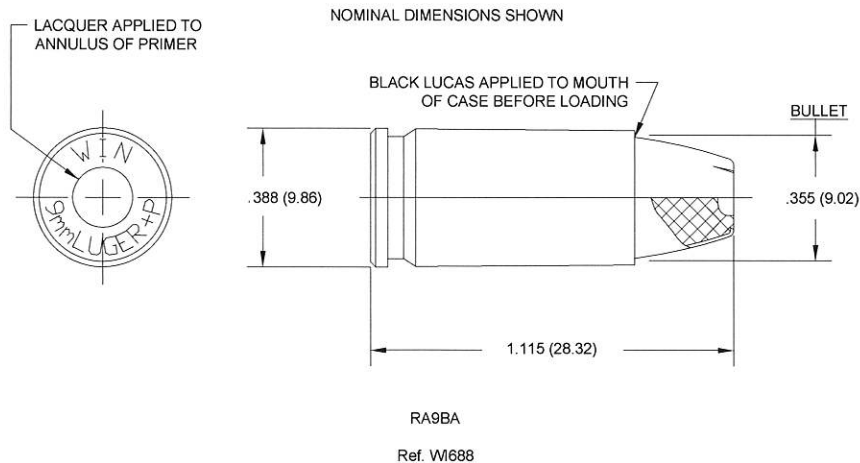

INFORMATION PUBLISHED HEREIN IS SUBJECT TO CHANGE AT MANUFACTURER'S DISCRETION WITHOUT NOTICE.

PRODUCT INFORMATION SHEET #253
Rev. B 9-13-2005

OLIN CORPORATION • WINCHESTER DIVISION • 427 NORTH SHAMROCK STREET • EAST ALTON, IL 62024-1197
TELEPHONE: 618 258-2000 • WEB SITE: www.winchester.com



Winchester 40 S&W (180) FMJ Paramilitary

- Symbol: **Q4238** – Winchester 40 S&W (180) Full Metal Jacket Paramilitary
- Shellcase: 40 S&W brass shellcase
- Bullet: 180 grain (11.7 gram) Full Metal Jacket
Brass jacket, lead core
Diameter .400 inch (10.2 mm)
- Powder: Clean burning, low flash
- Primer: Winchester non-corrosive primer – boxer type
- Accuracy: Product Mean of 2.5 inches (6.4 cm) Extreme Spread
5 shot targets at 50 yards (45.7 m) from a 4 inch (10.2 cm) SAAMI test barrel
- Velocity: 985 ft/sec (300 m/s) nominal at 15 ft (4.6 m)
Fired in a 4 inch (10.2 cm) standard SAAMI test barrel
- Energy: 388 ft-lb (526 joules)
- Pressure: 35,000 psi max. average (2,414 bars)
- Waterproofing: None

NOMINAL DIMENSIONS SHOWN

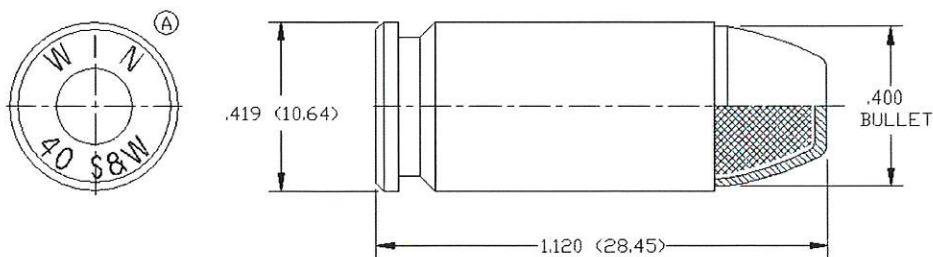

Q4238

REF. W1707

INFORMATION PUBLISHED HEREIN IS SUBJECT TO CHANGE AT MANUFACTURER'S DISCRETION WITHOUT NOTICE.

Rev. 07-30-2012, ECO 33013

OLIN CORPORATION • WINCHESTER DIVISION • 600 POWDER MILL RD • EAST ALTON, IL 62024-1197
TELEPHONE: 618 258-2000 • WEB SITE: www.winchester.com



WINCHESTER
AMMUNITION

Winchester 40 S&W (180) Ranger® Bonded JHP

- Symbol: **RA40B** – Winchester Ranger Bonded
- Shellcase: 40 S&W nickel plated brass shellcase
- Bullet: 180 grain (11.7 gram) Bonded JHP
Reversed Taper Bullet Jacket Bonded to Lead Core
Diameter .400 inch (10.16 mm)
- Powder: Clean burning, low flash
- Primer: Winchester non-corrosive primer, boxer type
- Accuracy: Product Mean of 2.25 inches (5.7 cm) Extreme Spread
5 shot targets at 50 yards (45.7 m) from a 4 inch (10.2 cm) SAAMI test barrel
- Velocity: 1020 ft/sec (311 m/s) nominal at 15 ft (4.6 m)
Fired in a 4 inch (10.2 cm) standard SAAMI test barrel
- Energy: 415 ft-lb (563 joules) nominal at 15 ft (4.6 m)
- Pressure: 35,000 psi max. average (2413 bars)
- Waterproofing: Lacquer applied to primer annulus and Black Lucas applied to mouth of case

NOMINAL DIMENSIONS SHOWN

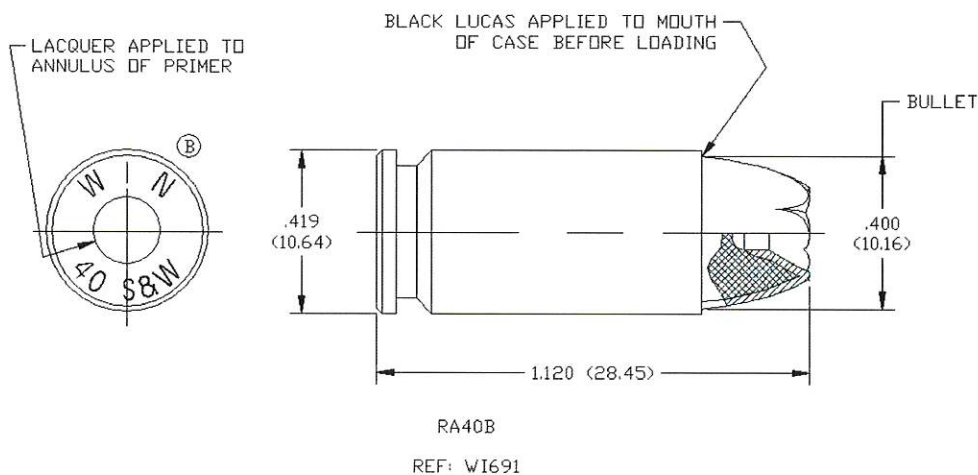

INFORMATION PUBLISHED HEREIN IS SUBJECT TO CHANGE AT MANUFACTURER'S DISCRETION WITHOUT NOTICE.
REFERENCE OLIN DRAWING W1691
Revised: 07-30-2012, ECO33013



Winchester 357 Sig (125) Bonded JHP

- Symbol: **RA357SB** – Winchester Ranger Bonded
- Shellcase: 357 Sig nickel plated brass shellcase
- Bullet: 125 grain (8.1 gram) Bonded JHP; Bullet Jacket Bonded to Lead Core
Diameter .355 inch (9.02 mm)
- Powder: Clean burning, low flash
- Primer: Winchester non-corrosive primer, boxer type
- Accuracy: Product Mean of 1.5 inches (3.8 cm) Extreme Spread
5 shot targets at 25 yards (22.9 m) from a 4 inch (10.2 cm) SAAMI test barrel
- Velocity: 1350 ft/sec (411 m/s) nominal at 15 ft (4.6 m)
Fired in a 4 inch (10.2 cm) standard SAAMI test barrel
- Energy: 506 ft-lb (686 joules)
- Pressure: 40,000 psi max. average (2,759 bars)
- Waterproofing: Black Lucas applied to mouth of shellcase

NOMINAL DIMENSIONS SHOWN

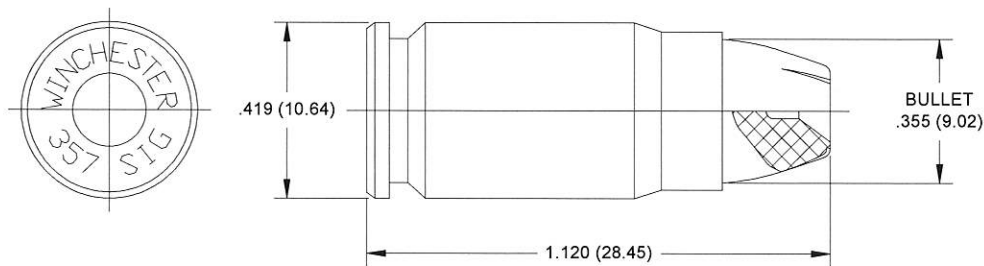

RA357SB

REF. WI596

INFORMATION PUBLISHED HEREIN IS SUBJECT TO CHANGE AT MANUFACTURER'S DISCRETION WITHOUT NOTICE.

PRODUCT INFORMATION SHEET #192

Rev. 6-30-2003

OLIN CORPORATION • WINCHESTER DIVISION • 427 NORTH SHAMROCK STREET • EAST ALTON, IL 62024-1197
TELEPHONE: 618 258-2000 • WEB SITE: www.winchester.com



Winchester 357 Sig (125) FMJ Paramilitary

- Symbol: **Q4309** – Winchester Full Metal Jacket Paramilitary
- Shellcase: 357 Sig brass shellcase
- Bullet: 125 grain (8.1 gram) Full Metal Jacket
Brass jacket, lead core
Diameter .355 inch (9.02 mm)
- Powder: Clean burning, low flash
- Primer: Winchester non-corrosive primer - boxer type
- Accuracy: Product Mean of 2.0 inches (5.1 cm) Extreme Spread
5 shot targets at 50 yards (45.7 m) from a 4 inch (10.2 cm) SAAMI test barrel
- Velocity: 1350 ft/sec (411 m/s) nominal at 15 ft (4.6 m)
Fired in a 4 inch (10.2 cm) standard SAAMI test barrel
- Energy: 506 ft-lb (686 joules)
- Pressure: 40,000 psi max. average (2,759 bars)
- Waterproofing: None

NOMINAL DIMENSIONS SHOWN

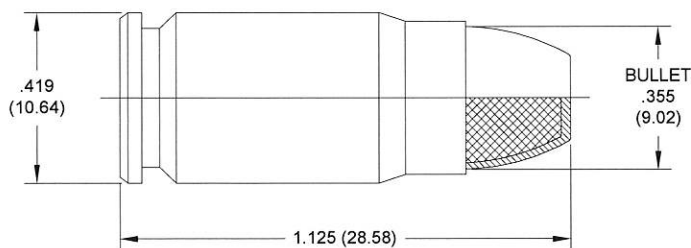

Q4309

WI730

INFORMATION PUBLISHED HEREIN IS SUBJECT TO CHANGE AT MANUFACTURER'S DISCRETION WITHOUT NOTICE.

PRODUCT INFORMATION SHEET #301

Rev. 6-14-2006

OLIN CORPORATION • WINCHESTER DIVISION • 427 NORTH SHAMROCK STREET • EAST ALTON, IL 62024-1197
TELEPHONE: 618 258-2000 • WEB SITE: www.winchester.com



Winchester 38 Special (130) FMJ Paramilitary

Symbol:	Q4171 – Winchester Full Metal Jacket Paramilitary
Shellcase:	38 Special brass shellcase
Bullet:	130 grain (8.4 gram) Full Metal Jacket – flat nose Brass jacket, lead core Diameter 0.3570 inch (9.07 mm)
Powder:	Clean burning, low flash
Primer:	Winchester non-corrosive primer – boxer type
Accuracy:	Product Mean of 3.5 inches (8.9 cm) Extreme Spread 5 shot targets at 50 yards (45.7 m) from a 7.71 inch (19.6 cm) SAAMI test barrel
Velocity:	950 ft/sec (290 m/s) nominal at 15 ft (4.6 m) Fired in a 7.71 inch (19.6cm) standard SAAMI test barrel
Energy:	260 ft-lb (352 joules)
Pressure:	17,000 psi max. average (1,172 bars)
Waterproofing:	None

NOMINAL DIMENSIONS SHOWN

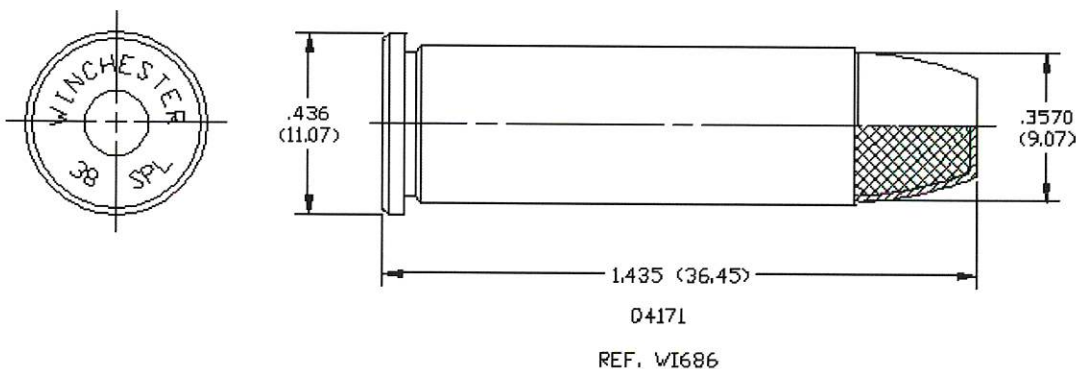

INFORMATION PUBLISHED HEREIN IS SUBJECT TO CHANGE AT MANUFACTURER'S DISCRETION WITHOUT NOTICE.

Rev. - 1-5-2017

OLIN CORPORATION • WINCHESTER DIVISION • 600 POWDER MILL RD • EAST ALTON, IL 62024-1197
TELEPHONE: 618 258-2000 • WEB SITE: www.winchester.com



WINCHESTER
A M M U N I T I O N

Winchester 45 Auto (230) FMJ

Symbol: **Q4170** - 45 Auto (230) FMJ Ball
Shellcase: 45 Auto brass shellcase with cap lacquer.
Bullet: 110 grain jacketed hollow point
Lot Identification: Ammunition is assigned a unique identification number to include the day, month and year of manufacture and assembly line on which it was manufactured.
Accuracy: Product mean of 1.90" - Five 5-shot targets at 50 yards from a SAMMI standard 5" test barrel.
Velocity: 830 \pm 45 ft/sec at 15 ft using a SAAMI standard 5" vented test barrel.
Pressure: 21,000 psi SAAMI maximum average pressure.
Bullet Pull/Push: Minimum pull = 50 lb., minimum push = 50 lb.
Propellant Detection: 100% mechanical and/or electrical detection of propellant levels within the cartridge.
Visual Inspection: 100% visual inspection of finished cartridges prior to packaging.
Loaded Round Length 1.245" - 1.275"



Winchester 45 Auto (230) Bonded JHP

- Symbol: **RA45B** – Winchester Ranger Bonded
- Shellcase: 45 Auto nickel plated brass shellcase with cap lacquer and mouth lacquer
- Bullet: 230 grain (14.9 gram) Bonded JHP; Bullet Jacket Bonded to Lead Core
Diameter .450 inch (11.43 mm)
- Powder: Clean burning, low flash
- Primer: Winchester non-corrosive primer, boxer type
- Accuracy: Product Mean of 1.5 inches (3.8 cm) Extreme Spread
5 shot targets at 50 yards (45.7 m) from a 5 inch (12.7 cm) SAAMI test barrel
- Velocity: 900 ft/sec (274 m/s) nominal at 15 ft (4.6 m)
Fired in a 5 inch (12.7 cm) SAAMI test barrel
- Energy: 414 ft-lb (561 joules)
- Pressure: 21,000 psi max. average (1448 bars)
- Waterproofing: Lacquer applied to primer annulus and Black Lucas applied to mouth of case



INFORMATION PUBLISHED HEREIN IS SUBJECT TO CHANGE AT MANUFACTURER'S DISCRETION WITHOUT NOTICE.

PRODUCT INFORMATION SHEET #282

Rev. - 9-19-2005

OLIN CORPORATION • WINCHESTER DIVISION • 427 NORTH SHAMROCK STREET • EAST ALTON, IL 62024-1197
TELEPHONE: 618 258-2000 • WEB SITE: www.winchester.com



Winchester 12 Ga. 2 3/4" 8 pellets 00 Buck - Low Recoil

- Symbol: **RA120085** – Winchester Ranger® Buckshot Low Recoil load
- Shellcase: 12 Ga. 2 3/4" Zinc Plated Low Steel Head, Red Plastic Tube
- Shot: 8 pellets 00 buckshot
- Powder: Clean burning, low flash
- Primer: Winchester non-corrosive battery cup primer
- Patterns: % pellets in 30 inch circle at 40 yards using a full choke barrel
Product Mean = 99%
Minimum Average = 90% (5 shots)
- Velocity: 1,145 ft/sec (349 m/s) nominal at 3 ft (0.9 m)
Fired in a 30 inch (76 cm) standard SAAMI test barrel
- Energy: 1190 ft-lb (1613 joules)
- Pressure: 11,500 psi maximum average (793 bars)
- Waterproofing: Applied to joint between the primer cup and battery cup

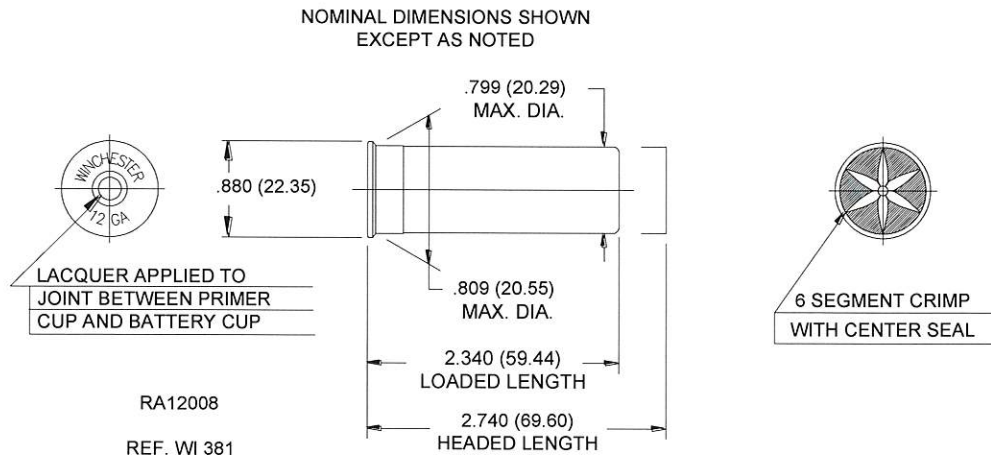

INFORMATION PUBLISHED HEREIN IS SUBJECT TO CHANGE AT MANUFACTURER'S DISCRETION WITHOUT NOTICE.

PRODUCT INFORMATION SHEET #191
Rev. - 6-30-2003

OLIN CORPORATION • WINCHESTER DIVISION • 427 NORTH SHAMROCK STREET • EAST ALTON, IL 62024-1197
TELEPHONE: 618 258-2000 • WEB SITE: www.winchester.com



Winchester 12 Ga. 2 3/4" 1 oz. Rifled Slug - Low Recoil

- Symbol: **RA12RS15** – Winchester Ranger® Rifled Slug Low Recoil load
- Shellcase: 12 Ga. 2 3/4" Zinc Plated Low Steel Head, White Plastic Tube
- Slug: 1 oz. (28 grams) Lead Hollow Point Rifled Slug
- Powder: Clean burning, low flash
- Primer: Winchester non-corrosive battery cup primer
- Accuracy: 2.5 inches (6.3 cm) Extreme Spread - Product Mean
5.5 inches (14.0 cm) Extreme Spread – Maximum Average
3 x 5 shot groups at 40 yards (36.6 m) tested in improved cylinder choke barrel
- Velocity: 1,200 ft/sec (366 m/s) nominal at 3 ft (0.9 m)
Fired in a 30 inch (76 cm) standard SAAMI test barrel
- Energy: 1400 ft-lb (1898 joules)
- Pressure: 11,500 psi maximum average (793 bars)
- Waterproofing: Applied to joint between primer cup and battery cup

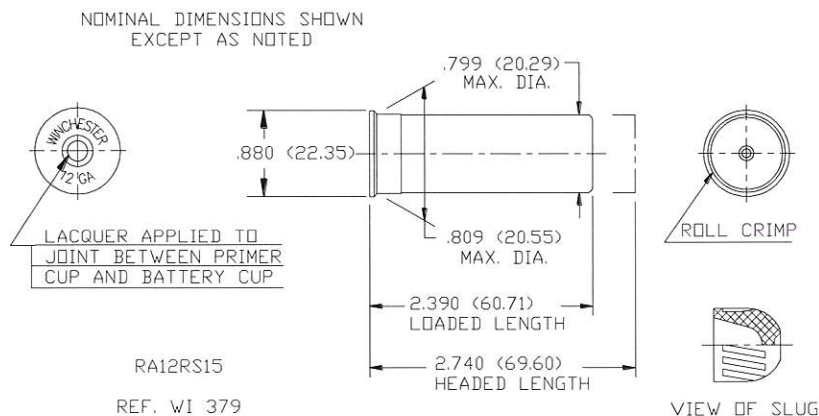

INFORMATION PUBLISHED HEREIN IS SUBJECT TO CHANGE AT MANUFACTURER'S DISCRETION WITHOUT NOTICE.

PRODUCT INFORMATION SHEET #124
Rev. - 6-21-2000



Winchester 12 Ga. 2 3/4" Super-Target Load – 7 1/2 Shot

- Symbol: TRGT127 – Winchester Super-Target Load
- Shellcase: 12 Ga. 2 3/4" Zinc Plated Low Steel Head, Red Plastic Tube
- Shot: 1 1/8 ounce (32 gram) #7 1/2 lead shot
- Powder: Clean burning, low flash
- Primer: Winchester non-corrosive battery cup primer
- Patterns: % pellets in 30 inch (76 cm) circle at 40 yards (37m) using a full choke barrel
Minimum Average = 70% (5 shots)
- Velocity: 1145 ft/sec (349 m/s) nominal at 3 ft (0.9 m)
Fired in a 30 inch (76 cm) standard SAAMI test barrel
- Energy: 1433 ft-lb (1943 joules)
- Pressure: 11,500 psi maximum average (793 bars)

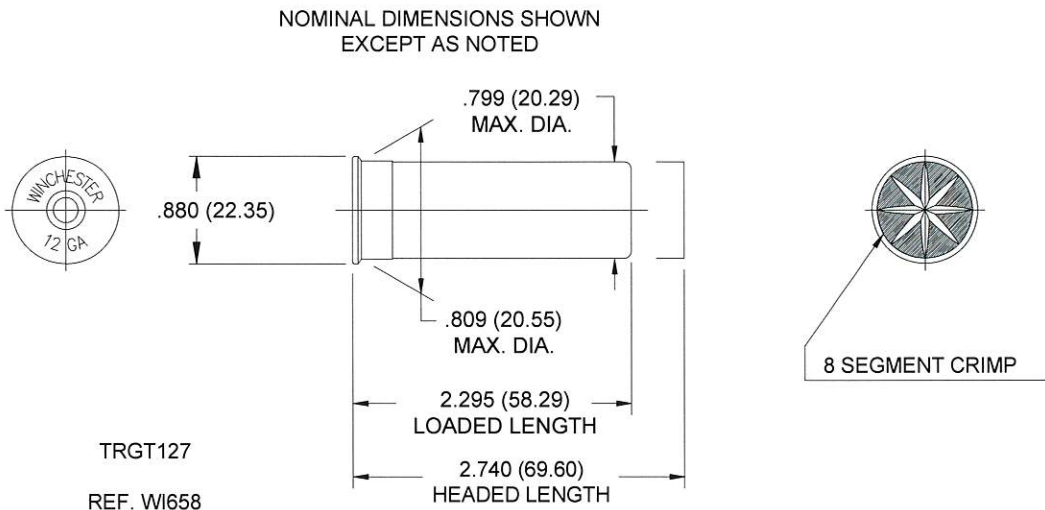

INFORMATION PUBLISHED HEREIN IS SUBJECT TO CHANGE AT MANUFACTURER'S DISCRETION WITHOUT NOTICE.

PRODUCT INFORMATION SHEET #256
Rev. - 10-18-2004

OLIN CORPORATION • WINCHESTER DIVISION • 427 NORTH SHAMROCK STREET • EAST ALTON, IL 62024-1197
TELEPHONE: 618 258-2000 • WEB SITE: www.winchester.com



30-30 Winchester, 150 Grain

POWER MAX BONDED

X30306BP \$

★★★★☆ 4.1 (16) [Write a review](#) [Ask a question](#)

Power Max Bonded ammunition, designed specifically with the whitetail deer hunter in mind. Winchester tradition of legendary excellence with a proprietary bonding process that delivers rapid expansion, long-range accuracy, and results in maximum knock-down power.

USAGE:

BRAND: **Power Max Bonded**

ROUNDS PER BOX: 20

ROUNDS PER CASE: 200



Features Ballistics Gallery

Convert Units US ▾

DISTANCE (YARDS)	VELOCITY (FPS)	ENERGY (FT-LBS)	TRAJ SHORT RANGE (IN)	TRAJ LONG RANGE (IN)
muzzle	2390	1902		
50			0.4	
100	2028	1370	0	3.8
200	1702	965	-7.6	0
300	1420		-27.4	-16
400	1198		-64.6	-49.3
500	1052			

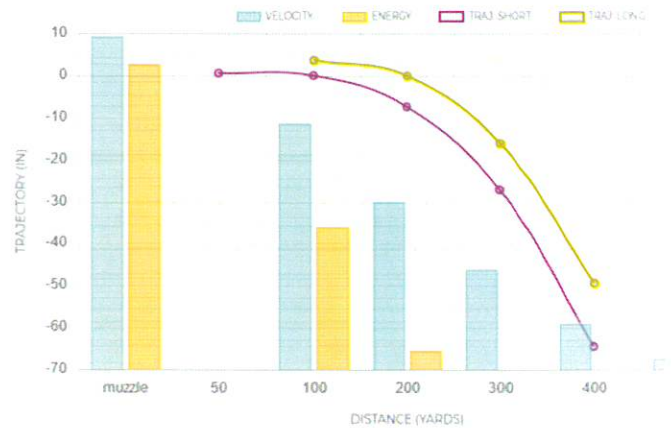

Home / Shotshell / Super X / XP12



12 Gauge, 2.75"

📍 WHERE TO BUY

SUPER X

XP12 \$

★★★★★ 4.2 (9) [Write a review](#) [Ask a question](#)

Since 1922, Super-X ammunition has provided exceptional quality and outstanding performance for all types of hunters and shooters who rely on its time-proven dependability backed by legendary excellence.

BRAND: **Super X**

ROUNDS PER BOX: 25

ROUNDS PER CASE: 250



[Features](#) [Ballistics](#) [Gallery](#)

Clean Burning Smokeless Blank

Realistic sound

Great Training Load

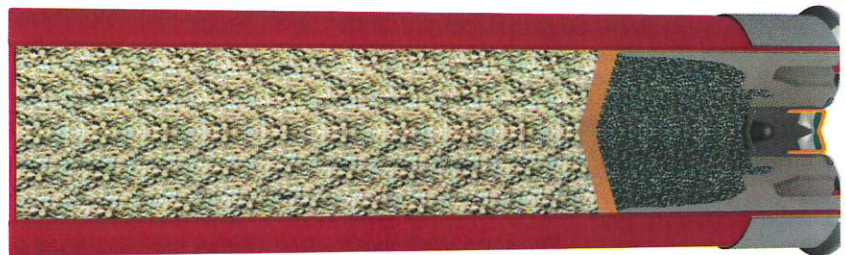



COUNTY PURCHASING AGENT
Fort Bend County, Texas

Vendor Information

Jaime Kovar
County Purchasing Agent

Office (281) 341-8640

Legal Company Name (top line of W9)	TXAT LLC		
Business Name (if different from legal name)			
Federal ID # or S.S. #	45-4008321	DUNS #	
Type of Business	<input checked="" type="checkbox"/> Corporation/LLC <input type="checkbox"/> Sole Proprietor/Individual	<input type="checkbox"/> Partnership <input type="checkbox"/> Tax Exempt Organization	Age in Business? 9
Publicly Traded Business	<input checked="" type="checkbox"/> No <input type="checkbox"/> Yes Ticker Symbol _____		
Remittance Address	3200 Kirby DR Suite 801		
City/State/Zip	Houston, TX 77098		
Physical Address	3200 Kirby DR Suite 801		
City/State/Zip	Houston, TX 77098		
Phone/Fax Number	Phone: (888)452-4019 Fax: _____		
Contact Person	Robin Eaves (864) 630-4952		
E-mail	robin@TX-AT.com		
Check all that apply to the company listed above and provide certification number.	DBE-Disadvantaged Business Enterprise _____	Certification # _____	
	SBE-Small Business Enterprise _____	Certification # _____	
	HUB -Texas Historically Underutilized Business _____	Certification # Pending	
	WBE-Women's Business Enterprise _____	Certification # _____	
Company's gross annual receipts	<\$500,000 _____	\$500,000-\$4,999,999 _____	
	\$5,000,000-\$16,999,999 _____	\$17,000,000-\$22,399,999 _____	
	>\$22,400,000 <input checked="" type="checkbox"/>		
NAICs codes (Please enter all that apply)			
Signature of Authorized Representative			
Printed Name	MIKE SMART		
Title	CONTROLLER		
Date	1/18/21		

THIS FORM MUST BE SUBMITTED WITH THE SOLICITATION RESPONSE

**Fort Bend County, Texas
Invitation for Bid**



**Term Contract for Purchase of Ammunition
BID 21-046**

SUBMIT BIDS TO:

Fort Bend County
Purchasing Department
Travis Annex
301 Jackson, Suite 201
Richmond, TX 77469

Note: All correspondence must include the term "Purchasing Department" in address to assist in proper delivery.

SUBMIT NO LATER THAN:

Tuesday, January 19, 2021
2:00 PM (Central)

LABEL ENVELOPE:

BID 21-046
AMMUNITION

***ALL BIDS MUST BE RECEIVED IN AND TIME/DATE STAMPED BY THE PURCHASING OFFICE
OF FORT BEND COUNTY BEFORE THE SPECIFIED TIME/DATE STATED ABOVE.
BIDS RECEIVED AS REQUIRED WILL THEN BE OPENED AND PUBLICLY READ.
BIDS RECEIVED AFTER THE SPECIFIED TIME, WILL BE RETURNED UNOPENED.***

Results will not be given by phone.
Results will be provided to bidder in writing
after the Commissioners Court awards.

Requests for information must be in
writing and directed to:
Cheryl Krejci, CPPB
Senior Buyer
cheryl.krejci@fortbendcountytexas.gov

Vendor Responsibilities:

- Download and complete any addendums. (Addendums will be posted on the Fort Bend County website no later than 48 hours prior to bid opening)
- Submit response in accordance with requirements stated on the cover of this document.
- DO NOT submit responses via email or fax.

Prepared: 12/15/20
Issued: 01/03/21

1.0 GENERAL REQUIREMENTS:

- 1.1 Read this entire document carefully. Follow all instructions. You are responsible for fulfilling all requirements and specifications. Be sure you understand them.
- 1.2 General Requirements apply to all advertised bids, however, these may be superseded, whole or in part, by the scope, special requirements, specifications, special specifications or other data contained herein.
- 1.3 Governing Law: Bidder is advised that these requirements shall be fully governed by the laws of the State of Texas and that Fort Bend County may request and rely on advice, decisions and opinions of the Attorney General of Texas and the County Attorney concerning any portion of these requirements.
- 1.4 Bid Document Completion: Fill out, initial each page, sign, and return ONE (1) complete bid document to the Fort Bend County Purchasing Department. An authorized representative of the bidder must sign the Contract Sheet. Do not complete the date at the top of the contract sheet. The bid document must be in a sealed envelope marked with the appropriate bid number and title. The contract will be binding only when signed by the County Judge, Fort Bend County and a purchase order authorizing the item(s) desired has been issued. The use of correction fluid is not acceptable and may result in the disqualification of bid. If an error is made, the bidder must draw a line through error and initial each change. All response, typed or written, information must be clear and legible.

If a pricing form in Excel is included and posted on the County's website amongst this bid document, the Vendor must download, complete and save the Excel (not a PDF of the Excel file) file of the pricing form on a CD or flash drive. The Excel file on the CD or flash drive must be downloadable by the Purchasing Department in order to copy and paste the vendor's pricing to the County's tabulation. The CD or flash drive must be labeled and included in the same sealed envelope with the respondent's completed bid document along with a printed copy of the pricing form completed by the vendor.

- 1.5 Bid Returns: Bidders must return completed bid document to the Fort Bend County Purchasing Department at 301 Jackson, Suite 201, Richmond, Texas no later than 2:00 P.M. on the date specified. Late bids will not be accepted. Bids must be submitted in a sealed envelope, addressed as follows: Fort Bend County Purchasing Agent, Travis Annex, 301 Jackson, Suite 201, Richmond, Texas 77469.
- 1.6 Governing Document: In the event of any conflict between the terms and provisions of these requirements and the specifications, the specifications shall govern. In the event of any conflict of interpretation of any part of this overall document, Fort Bend County's interpretation shall govern.

Initials of Bidder: 

- 1.7 Addenda: No interpretation of the meaning of the drawings, specifications or other bid documents will be made to any bidder orally. All requests for such interpretations must be made in writing addressed to Ms. Cheryl Krejci, Senior Buyer, 301 Jackson, Suite 201, Richmond, Texas 77469, e-mail: cheryl.krejci@fortbendcountytexas.gov. Any and all interpretations and any supplemental instructions will be in the form of written addenda to the contract documents which will be posted on Fort Bend County's website. Addenda will **ONLY** be issued by the Fort Bend County Purchasing Agent. It is the sole responsibility of each bidder to insure receipt of any and all addenda. All addenda issued will become part of the contract documents. Bidders must sign and include addendum in the returned bid package. Deadline for submission of questions and/or clarification is **Tuesday, January 12, 2021 at 9:00 AM (CST)**. Requests received after the deadline will not be responded to due to the time constraints of this bid process.
- 1.8 Hold Harmless Agreement: Contractor shall indemnify and hold Fort Bend County harmless from all claims for personal injury, death and/or property damage arising from any cause whatsoever, resulting directly or indirectly from contractor's performance. Contractor shall procure and maintain, with respect to the subject matter of this bid, appropriate insurance coverage including, as a minimum, public liability and property damage with adequate limits to cover contractor's liability as may arise directly or indirectly from work performed under terms of this bid. Certification of such coverage must be provided to the County upon request.
- 1.9 Waiver of Subrogation: Bidder and bidder's insurance carrier waive any and all rights whatsoever with regard to subrogation against Fort Bend County as an indirect party to any suit arising out of personal or property damages resulting from bidder's performance under this agreement.
- 1.10 Severability: If any section, subsection, paragraph, sentence, clause, phrase or word of these requirements or the specifications shall be held invalid, such holding shall not affect the remaining portions of these requirements and the specifications and it is hereby declared that such remaining portions would have been included in these requirements and the specifications as though the invalid portion had been omitted.
- 1.11 Bonds: If this bid requires submission of bid guarantee and performance bond, there will be a separate page explaining those requirements. Bids submitted without the required bid bond or cashier's checks are not acceptable. Bond/s or cashier's check must be complete with all required signatures.
- 1.12 Taxes: Fort Bend County is exempt from all federal excise, state and local taxes unless otherwise stated in this document. Fort Bend County claims exemption from all sales and/or use taxes under Chapter 20, Title 122a, Vernon's Texas Civil Statutes, as amended. Texas Limited Sales Tax Exemption Certificates will be furnished upon written request to the Fort Bend County Purchasing Department.

Initials of Bidder



- 1.13 Fiscal Funding: A multi-year lease or lease/purchase arrangement (if requested by the specifications), or any contract continuing as a result of an extension option, must include fiscal funding out. If, for any reason, funds are not appropriated to continue the lease or contract, said lease or contract shall become null and void. After expiration of the lease, leased equipment shall be removed by the bidder from the using department without penalty of any kind or form to Fort Bend County. All charges and physical activity related to delivery, installation, removal and redelivery shall be the responsibility of the bidder.
- 1.14 Pricing: Prices for all goods and/or services shall be firm for the duration of this contract and shall be stated in the bid spreadsheet. Prices shall be all inclusive. No price changes, additions, or subsequent qualifications will be honored during the course of the contract. All prices must be written in ink or typewritten. Pricing on all transportation, freight, and other charges are to be prepaid by the contractor and included in the bid prices. If there are any additional charges of any kind, other than those mentioned above, specified or unspecified, bidder MUST indicate the items required and attendant costs or forfeit the right to payment for such items.
- 1.15 Silence of Specifications: The apparent silence of specifications as to any detail, or the apparent omission from it of a detailed description concerning any point, shall be regarded as meaning that only the best commercial practice is to prevail and that only material and workmanship of the finest quality are to be used. All interpretations of specifications shall be made on the basis of this statement. The items furnished under this contract shall be new, unused of the latest product in production to commercial trade and shall be of the highest quality as to materials used and workmanship. Manufacturer furnishing these items shall be experienced in design and construction of such items and shall be an established supplier of the item bid.
- 1.16 Supplemental Materials: Bidders are responsible for including all pertinent product data in the returned bid package. Literature, brochures, data sheets, specification information, completed forms requested as part of the bid package and any other facts which may affect the evaluation and subsequent contract award should be included. Materials such as legal documents and contractual agreements, which the bidder wishes to include as a condition of the bid, must also be in the returned bid package. Failure to include all necessary and proper supplemental materials may be cause to reject the entire bid.
- 1.17 Material Safety Data Sheets: Under the "Hazardous Communication Act", commonly known as the "Texas Right To Know Act", a bidder must provide to County and using departments, with each delivery, material safety data sheets, which are, applicable to hazardous substances defined in the Act. Bidders are obligated to maintain a current, updated file in the Fort Bend County Purchasing Department. Failure of the bidder to maintain such a file will be cause to reject any bid applying thereto.

Initials of Bidder: 

- 1.18 Name Brands: Specifications may reference name brands and model numbers. It is not the intent of Fort Bend County to restrict these bids in such cases, but to establish a desired quality level of merchandise or to meet a pre-established standard due to like existing items. Bidders may offer items of equal stature and the burden of proof of such stature rests with them. Fort Bend County shall act as sole judge in determining equality and acceptability of products offered.
- 1.19 Color Selection: Determination of colors of materials is a right reserved by the using department unless otherwise specified in the bid. Unspecified colors shall be quoted as standard colors, not colors, which require up charges or special handling. Unspecified fabrics or vinyl should be construed as medium grade. If bidder fails to get color/material approvals prior to delivery of merchandise, the using department may refuse to accept the items and demand correct shipment without penalty, subject to other legal remedies.
- 1.20 Evaluation: Evaluation shall be used as a determinant as to which bid items or services are the most efficient and/or most economical for the County. It shall be based on all factors, which have a bearing on price and performance of the items in the user environment. All bids are subject to tabulation by the Fort Bend County Purchasing Department and recommendation to Fort Bend County Commissioners Court. Compliance with all bid requirements, delivery and needs of the using department are considerations in evaluating bids. Pricing is NOT the only criteria for making a recommendation. The Fort Bend County Purchasing Department reserves the right to contact any bidder, at any time, to clarify, verify or request information with regard to any bid.
- 1.21 Inspections: Fort Bend County reserves the right to inspect any item(s) or service location for compliance with specifications and requirements and needs of the using department. If a bidder cannot furnish a sample of a bid item, where applicable, for review, or fails to satisfactorily show an ability to perform, the County can reject the bid as inadequate.
- 1.22 Testing: Fort Bend County reserves the right to test equipment, supplies, material and goods bid for quality, compliance with specifications and ability to meet the needs of the user. Demonstration units must be available for review. Should the goods or services fail to meet requirements and/or be unavailable for evaluation, the bid is subject to rejection.
- 1.23 Disqualification of Bidder: Upon signing this bid document, a bidder offering to sell supplies, materials, services, or equipment to Fort Bend County certifies that the bidder has not violated the antitrust laws of this state codified in section 15.01, et seq., Business & Commerce Code, or the federal antitrust laws, and has not communicated directly or indirectly the bid made to any competitor or any other person engaged in such line of business. Any or all bids may be rejected if the County believes that collusion exists among the bidders. Bids in which the prices are

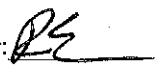
Initials of Bidder: 

obviously unbalanced may be rejected. If multiple bids are submitted by a bidder and after the bids are opened, one of the bids is withdrawn, the result will be that all of the bids submitted by that bidder will be withdrawn; however, nothing herein prohibits a vendor from submitting multiple bids for different products or services.

- 1.24 Awards: Fort Bend County reserves the right to award this contract on the basis of lowest and best bid in accordance with the laws of the State of Texas, to waive any formality or irregularity, to make awards to more than one bidder, to reject any or all bids. In the event the lowest dollar bidder meeting specifications is not awarded a contract, the bidder may appear before the Commissioners Court and present evidence concerning his responsibility. An award is final only upon formal execution by the Fort Bend County Commissioners Court or the Fort Bend County Purchasing Agent. Fort Bend County reserves the right to withdraw any award until execution by the proper authority.
- 1.25 Assignment: The successful vendor may not assign, sell or otherwise transfer this contract without written permission of Fort Bend County Commissioners Court.
- 1.26 Term Contracts: If the contract is intended to cover a specific time period, said time will be given in the specifications under scope.
- 1.27 Maintenance: Maintenance required for equipment bid should be available in Fort Bend County by a manufacturer authorized maintenance facility. Costs for this service shall be shown on the bid sheet as requested or on a separate sheet, as required. If Fort Bend County opts to include maintenance, it shall be so stated in the purchase order and said cost will be included. Service will commence only upon expiration of applicable warranties and should be priced accordingly.
- 1.28 Contract Obligation: Fort Bend County Commissioners Court must award the contract and the County Judge or other person authorized by the Fort Bend County Commissioners Court must sign the contract before it becomes binding on Fort Bend County or the bidders. Department heads are not authorized to sign agreements for Fort Bend County. Binding agreements shall remain in effect until all products and/or services covered by this purchase have been satisfactorily delivered and accepted.
- 1.29 Title Transfer: Title and Risk of Loss of goods shall not pass to Fort Bend County until Fort Bend County actually receives and takes possession of the goods at the point or points of delivery. Receiving times may vary with the using department. Generally, deliveries may be made between 8:30 a.m. and 4:00 p.m., Monday through Friday. Bidders are advised to consult the using department for instructions. The place of delivery shall be shown under the "Special Requirement" section of this bid document and/or on the Purchase Order as a "Ship To:" address.
- 1.30 Purchase Order and Delivery: The successful bidder shall not deliver products or

Initials of Bidder: 

provide services without a Fort Bend County Purchase Order, signed by an authorized agent of the Fort Bend County Purchasing Department. The fastest, most reasonable delivery time shall be indicated by the bidder in the proper place on the bid sheet. Any special information concerning delivery should also be included, on a separate sheet, if necessary. All items shall be shipped F.O.B. inside delivery unless otherwise stated in the specifications. This shall be understood to include bringing merchandise to the appropriate room or place designated by the using department. Every tender or delivery of goods must fully comply with all provisions of these requirements and the specifications including time, delivery and quality. Nonconformance shall constitute a breach, which must be rectified prior to expiration of the time for performance. Failure to rectify within the performance period will be considered cause to reject future deliveries and cancellation of the contract by Fort Bend County without prejudice to other remedies provided by law. Where delivery times are critical, Fort Bend County reserves the right to award accordingly.

- 1.31 Contract Extension: Extensions may be made only by written agreement between Fort Bend County and the bidder. Any price escalations are limited to those stated by the bidder in the original bid.
- 1.32 Termination: Fort Bend County reserves the right to terminate the contract for default if Seller breaches any of the terms therein, including warranties of bidder or if the bidder becomes insolvent or commits acts of bankruptcy. Such right of termination is in addition to and not in lieu of any other remedies, which Fort Bend County may have in law or equity. Default may be construed as, but not limited to, failure to deliver the proper goods and/or services within the proper amount of time, and/or to properly perform any and all services required to Fort Bend County's satisfaction and/or to meet all other obligations and requirements. Contracts may be terminated without cause upon thirty (30) days written notice to either party unless otherwise specified.
- 1.33 Recycled Materials: Fort Bend County encourages the use of products made of recycled materials and shall give preference in purchasing to products made of recycled materials if the products meet applicable specifications as to quantity and quality. Fort Bend County will be the sole judge in determining product preference application.
- 1.34 Interlocal Participation: Additional governmental entities may purchase from this bid. Vendor agrees to accept purchase orders from those participating entities and to invoice each entity separately.
- 1.35 Escalation Clause: Successful bidder may apply for a price increase to the Fort Bend County Purchasing Agent. The County Purchasing Agent will review, and, if increase is deemed warranted, place the request on Fort Bend County's Commissioners Court agenda for their action of approval or disapproval. Approval by the County's Commissioner's Court is required. Any proposed price increase will

Initials of Bidder:



only be the amount increased to the vendor from his/her supplier. The price increase request must be stated on the vendor's letterhead with the bid number and name in the subject including, in columns, for each item: item description, original bid price, percent of increase, and the total cost of the original bid price including the increased dollar amount. Written documentation from the vendor's supplier of the increase notice must be provided to the Purchasing Agent at time of increase request. No application for a price increase may be submitted within the first six (6) months of this contract. Increase requests of more than 25% of the original bid price will not be considered.

- 1.36 Modifications: This instrument contains the entire Contract between the parties relating to the rights herein granted and obligations herein assumed. Any oral or written representations or modifications concerning this instrument shall be of no force and effect excepting a subsequent written modification signed by both parties hereto.

2.0 TERMS & CONDITIONS:

- 2.1 Seller to Package Goods: Seller will package goods in accordance with good commercial practice. Each delivery container shall be clearly and permanently marked as follows (a) Seller's name and address; (b) Consignee's name, address and purchase order number and the bid number if applicable; (c) Container number and total number of containers (e.g. box 1 of 4 boxes); and (d) the number of the container bearing the packing slip. Seller shall bear cost of packaging unless otherwise provided. Goods shall be suitably packed to secure lowest transportation costs and to conform to requirements of common carriers and any applicable specifications. Fort Bend County's count or weight shall be final and conclusive on shipments not accompanied by packing list.
- 2.2 Shipment Under Reservation Prohibited: Seller is not authorized to ship goods under reservation and no tender of a bill of lading will operate as a tender of goods.
- 2.3 Title and Risk of Loss: The title and risk of loss of the goods shall not pass to the County until a County employee actually receives and takes possession of the goods at the point or points of delivery.
- 2.4 Delivery Terms: F.O.B. Destination Freight Prepaid, Inside Delivery, unless delivery terms are specified otherwise on Purchase Order.
- 2.5 No Replacement of Defective Tender: Every tender or delivery of goods must fully comply with all provisions of the Purchase Order as to time of delivery, quality and the like. If a tender is made which does not fully conform, this shall constitute a breach and Seller shall not have the right to substitute a conforming tender.
- 2.6 Place of Delivery: The place of delivery shall be that set forth in the block of the

Initials of Bidder: 

purchase order entitled "Ship To". Any change thereto shall be effective by modification as provided for in Clause number 2.20 "Modifications", hereof. The terms of this agreement are "no arrival, no sale", at the discretion of Fort Bend County.

2.7 Invoices and Payments:

2.7.1 Seller shall submit separate invoices, in duplicate. Invoices shall indicate the purchase order number and the bid number if applicable. Invoices shall be itemized and transportation charges, if any, shall be listed separately. A copy of the bill of lading, and the freight waybill when applicable should be attached to the invoice.

2.7.2 Fort Bend County's obligation is payable only and solely from funds available for the purpose of this purchase. Lack of funds shall render the order null and void to the extent funds are not available and any delivered but unpaid goods will be returned to Seller by the county.

2.7.3 Do not include Federal Excise, State, or City Sales Tax. Fort Bend County is a tax-exempt governmental entity.

2.8 Gratuities: Fort Bend County may, by written notice to the Seller, cancel any order without liability, if it is determined by the County that gratuities, in the form of entertainment, gifts, or otherwise were offered or given by the Seller, or any agent or representative of the Seller to any officer or employee of Fort Bend County with a view toward securing an order. In the event an order is canceled by the County pursuant to this provision, the County shall be entitled, in addition to any other rights and remedies, to recover or withhold the amount of the cost incurred by Seller in providing such gratuities.

2.9 Special Tools and Test Equipment: If the price stated on the face of an order includes the cost of any special tooling or special test equipment fabricated or required by Seller for the purpose of filing this order, such special tooling equipment and any process sheets related thereto shall become the property of the County and to the extent feasible shall be identified by the Seller as such.

2.10 Warranty/Price:

2.10.1 The price to be paid by the County shall be that contained in Seller's bid which Seller warrants to be no higher than Seller's current prices on orders by others for products of the kind and specification covered by an order for similar quantities under similar or like conditions and methods of purchase. In the event Seller breaches this warranty the prices of the items shall be reduced to the Seller's current prices on orders by others. Fort Bend County may cancel this contract without liability.

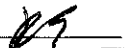
Initials of Bidder: 

- 2.10.2 The Seller warrants that no person or selling agency has been employed or retained to solicit or secure any County order based upon any agreement or understanding for commission, percentage, brokerage, or contingent fee excepting bona fide employees of bona fide established commercial or selling agencies maintained by the Seller for the purpose of securing business. A breach or violation of this warranty gives the County the right, in addition to any other right or rights, to cancel this contract without liability.
- 2.11 Warranty Product: Seller shall not limit or exclude any implied warranties and any attempt to do so shall render an order voidable at the option of the County. Seller warrants that the goods furnished will conform to the specifications, drawings, and description listed in the bid invitation and purchase order as applicable, and to the sample(s) furnished by Seller if any. In the event of a conflict between the specifications, drawings, and descriptions, the specifications shall govern.
- 2.12 Safety Warranty: Seller warrants that the product sold to Fort Bend County shall conform to the standards promulgated by the U.S. Department of Labor under the Occupational Safety and Health Act of 1970. In the event the product does not conform to OSHA standards, the County may return the product for correction or replacement at the Seller's expense. In the event Seller fails to make the appropriate correction within 10 days, correction made by the County will be at Seller's expense.
- 2.13 No Warranty by Fort Bend County Against Infringements: As part of a contract for sale Seller agrees to ascertain whether goods manufactured in accordance with the specifications will give rise to the rightful claim of any third person by way of infringement. Fort Bend County makes no warranty that the production of goods according to the specification will not give rise to such a claim and in no event shall Fort Bend County be liable to Seller for indemnification in the event the Seller is sued on the grounds of infringement or the like. If Seller is of the opinion that an infringement will result, he will notify Fort Bend County to this effect in writing within two days after the receiving Purchase Order. If the County does not receive notice and is subsequently held liable for the infringement, Seller will defend and save the County harmless. If Seller in good faith ascertains that production of the goods in accordance with the specifications will result in infringement, this contract shall be null and void except that the County will pay Seller the reasonable cost of his search as to infringements.
- 2.14 Right of Inspection: The County shall have the right to inspect the goods at delivery before accepting them.
- 2.15 Cancellation: Fort Bend County shall have the right to cancel for default all or any part of the undelivered portion of an order if Seller breaches any of the terms hereof including warranties of Seller, or if the Seller becomes insolvent or files for protection under the bankruptcy laws. Such rights of cancellation are in addition to and not in lieu of any other remedies, which Fort Bend County may have in law or

Initials of Bidder: 

equity.

- 2.16 Termination: The performance of work under a Purchase Order may be terminated in whole or in part by the County in accordance with this provision. Termination of work there under shall be effected by the delivery to the Seller of a "Notice of Termination" specifying the extent to which performance of work under the order is terminated and the date upon which such termination becomes effective. Such right of termination is in addition to and not in lieu of rights of Fort Bend County set forth in Clause 15 herein.
- 2.17 Force Majeure: Force Majeure means a delay encountered by a party in the performance of its obligations under this Agreement, which is caused by an event beyond the reasonable control of that party. Without limiting the generality of the foregoing, "Force Majeure" shall include but not be restricted to the following types of events: acts of God or public enemy; acts of governmental or regulatory authorities; fires, floods, epidemics or serious accidents; unusually severe weather conditions; strikes, lockouts, or other labor disputes; and defaults by subcontractors.
- In the event of a Force Majeure, the affected party shall not be deemed to have violated its obligations under this Agreement, and the time for performance of any obligations of that party shall be extended by a period of time necessary to overcome the effects of the Force Majeure, provided that the foregoing shall not prevent this Agreement from terminating in accordance with the termination provisions. If any event constituting a Force Majeure occurs, the affected party shall notify the other parties in writing, within twenty-four (24) hours, and disclose the estimated length of delay, and cause of the delay.
- 2.18 Assignment-Delegation: No right or interest in an order shall be assigned or delegation of any obligation made by Seller without the written permission of Fort Bend County. Any attempted assignment or delegation by Seller shall be wholly void and totally ineffective for all purposes unless made in conformity with this paragraph.
- 2.19 Waiver: No claim or right arising out of a breach of any contract can be discharged in whole or in part by a waiver or renunciation of the claim or right unless the waived or renunciation is supported by consideration and is in writing signed by the aggrieved party.
- 2.20 Modification: A Purchase Order can be modified or rescinded only by a writing signed by both of the parties or their duly authorized agents.
- 2.21 Parol Evidence: This writing is intended by the parties as a final expression of their agreement and is intended also as a complete and exclusive statement of the terms of this agreement. No course of prior dealings between the parties and no usage of the trade shall be relevant to supplement or explain any terms rendered under this agreement and shall not be relevant to determine the meaning of this agreement even

Initials of Bidder: 

though the accepting or acquiescing party has knowledge of the performance and opportunity for objection. Whenever a term defined by the Uniform Commercial Code is used in this agreement, the definition contained in the Code is to control.

- 2.22 **Applicable Law:** This agreement shall be governed by the Uniform Commercial Code. Whenever the term "Uniform Commercial Code" is used it shall be construed as meaning the Uniform Commercial Code as adopted in the State of Texas and in effective on the date of the purchase order.
- 2.23 **Advertising:** Seller shall not advertise or publish, without the County's prior consent the fact that Fort Bend County has entered into any contract, except to the extent necessary to comply with proper requests for information from an authorized representative of the federal, state, or local government.
- 2.24 **Right to Assurance:** Whenever the County in good faith has reason to question the other party's intent to perform. The County may demand that the other party give written assurance of his intent to perform. In the event that a demand is made and no assurance is given within five (5) days, the County may treat this failure as an anticipatory repudiation of the contract.
- 2.25 **Venue:** Both parties agree that venue for any litigation arising from this contract shall lie in Richmond, Fort Bend County, Texas.
- 2.26 **Prohibition Against Personal Interest in Contracts:** No officer or employee of the County shall have a financial interest, direct or indirect, in any contract with the County, or shall be financially interested, directly or indirectly, in the sale to the County of any land, materials, supplies, or service, except on behalf of the County as an officer or employee. Any willful violation of this section shall constitute malfeasance in office, and any officer or employee guilty thereof shall be subject to disciplinary action under applicable laws, statutes and codes of the State of Texas. Any violation of this section, with the knowledge, expressed or implied of the person or corporation contracting with the County shall render the contract involved voidable by the County Commissioners Court.

3.0 SCOPE:

It is the intent of Fort Bend County to contract with one (1) or more vendors to supply ammunition, which meets or exceeds the specifications contained herein.

4.0 TERM OF CONTRACT:

The term of this contract **April 1, 2021 through March 31, 2022**, renewable annually for two (2) years (through March 31, 2024) under the same terms and conditions if mutually agreeable by both parties. Either party for any reason may terminate this contract by giving thirty (30) days written notice of the intent to terminate.

Initials of Bidder: _____



5.0 TEXAS ETHICS COMMISSION FORM 1295:

- 5.1 Effective January 1, 2016 all contracts executed by Commissioners Court, regardless of the dollar amount, will require completion of Form 1295 "Certificate of Interested Parties", per the new Government Code Statute §2252.908. All vendors submitting a response to a formal Bid, RFP, SOQ or any contracts, contract amendments, renewals or change orders are required to complete the Form 1295 online through the State of Texas Ethics Commission website. Please visit: https://www.ethics.state.tx.us/whatsnew/elf_info_form1295.htm.
- 5.2 On-line instructions:
 - 5.2.1 Name of governmental entity is to read: Fort Bend County.
 - 5.2.2 Identification number used by the governmental entity is: B21-046.
 - 5.2.3 Description is the title of the solicitation: Ammunition.
- 5.3 Apparent low bidder(s) will be required to provide the Form 1295 within three (3) calendar days from notification; however, if your company is publicly traded you are not required to complete this form.

6.0 STATE LAW REQUIREMENTS FOR CONTRACTS:

The contents of this section are required by Texas Law and are included by County regardless of content.

- 6.1 Agreement to Not Boycott Israel Chapter 2270 Texas Government Code: By signature on vendor form, Contractor verifies Contractor does not boycott Israel and will not boycott Israel during the term of this Contract.
- 6.2 Texas Government Code Section 2251.152 Acknowledgment: By signature on vendor form, Contractor represents pursuant to Section 2252.152 of the Texas Government Code, that Contractor is not listed on the website of the Comptroller of the State of Texas concerning the listing of companies that are identified under Section 806.051, Section 807.051 or Section 2253.153.

7.0 HUMAN TRAFFICKING:

By acceptance of this contract, Contractor acknowledges that Fort Bend County is opposed to human trafficking and that no County funds will be used in support of services or activities that violate human trafficking laws.

Initials of Bidder:



Specifications are located in the Excel pricing forms downloadable from Fort Bend County's website. Provide bid prices in the electronic Excel file and return as stated in Section 1.4 and 1.5. Items 9.1 through 9.17 are to bid providing the specified Manufacture and Number. Items 9.18 through 9.39 are to be bid as specified or include the manufacture's name and number of the equal to item in the cell below the specified. See Name Brand Clause 1.18. All ammunition must be new and delivered in the original manufacturer's packaging. Minimum orders are not permitted.

10.0 DELIVERY:

Delivery of all items ordered must be completed within one hundred twenty (120) calendar days, unless otherwise noted, after receipt of purchase order issued by the Fort Bend County Purchasing Agent. If order cannot be fulfilled within this time frame, vendor is required to inform Fort Bend County Purchasing. Delivery must be made to the department listed on the purchase order.

11.0 AWARD:

This contract will be awarded to the low bidder meeting specifications per item.

12.0 REQUIRED FORMS:

All vendors submitting are required to complete and provide with submission along with any other documentation as stated herein:

12.1 Vendor Form

12.2 W9 Form

12.3 Tax Form/Debt/Residence Certification

Initials of Bidder: 

Contract Sheet
Bid 21-046

THE STATE OF TEXAS
COUNTY OF FORT BEND

This memorandum of agreement made and entered into on the 9th day of February, 20 21,
by and between Fort Bend County in the State of Texas (hereinafter designated County), acting herein by
County Judge KP George, by virtue of an order of Fort Bend County Commissioners Court, and
TXAT LLC (hereinafter designated Contractor).
(company name)

WITNESSETH:

The Contractor and the County agree that the bid and specifications for the **Purchase of Ammunition** which
are hereto attached and made a part hereof, together with this instrument and the bond (when required) shall
constitute the full agreement and contract between parties and for furnishing the items set out and described;
the County agrees to pay the prices stipulated in the accepted bid.

It is further agreed that this contract shall not become binding or effective until signed by the parties hereto
and a purchase order authorizing the items desired has been issued.

Executed at Richmond, Texas this 9 day of February 20 21.

KP George Fort Bend County, Texas
By: County Judge KP George
County Judge, KP George

By: [Signature]
Signature of Contractor

By: MIKE SMART - CONTROLLER
Printed Name and Title

Request for Taxpayer Identification Number and Certification

**Give Form to the
requester. Do not
send to the IRS.**

Print or type See Specific Instructions on page 2.	<p>1 Name (as shown on your income tax return). Name is required on this line; do not leave this line blank. TXAT LLC</p> <p>2 Business name/disregarded entity name, if different from above</p> <p>3 Check appropriate box for federal tax classification; check only one of the following seven boxes:</p> <table style="width: 100%; border: none;"> <tr> <td><input checked="" type="checkbox"/> Individual/sole proprietor or single-member LLC</td> <td><input type="checkbox"/> C Corporation</td> <td><input type="checkbox"/> S Corporation</td> <td><input type="checkbox"/> Partnership</td> <td><input type="checkbox"/> Trust/estate</td> </tr> </table> <p><small>limited liability company. Enter the tax classification (C=C corporation, S=S corporation, P=partnership) ▶ _____</small></p> <p><small>Note. For a single-member LLC that is disregarded, do not check LLC; check the appropriate box in the line above for the tax classification of the single-member owner.</small></p> <p><input type="checkbox"/> Other (see instructions) ▶ _____</p> <p>4 Exemptions (codes apply only to certain entities, not individuals; see instructions on page 3): Exempt payee code (if any) _____ Exemption from FATCA reporting code (if any) _____ <small>(Applies to accounts maintained outside the U.S.)</small></p> <p>5 Address (number, street, and apt. or suite no.) 3200 Kirby Dr. Suite 801</p> <p>6 City, state, and ZIP code Houston, TX 77098</p> <p>7 List account number(s) here (optional)</p> <p style="text-align: right;">Requester's name and address (optional)</p>	<input checked="" type="checkbox"/> Individual/sole proprietor or single-member LLC	<input type="checkbox"/> C Corporation	<input type="checkbox"/> S Corporation	<input type="checkbox"/> Partnership	<input type="checkbox"/> Trust/estate
<input checked="" type="checkbox"/> Individual/sole proprietor or single-member LLC	<input type="checkbox"/> C Corporation	<input type="checkbox"/> S Corporation	<input type="checkbox"/> Partnership	<input type="checkbox"/> Trust/estate		

Part I Taxpayer Identification Number (TIN)

Enter your TIN in the appropriate box. The TIN provided must match the name given on line 1 to avoid backup withholding. For individuals, this is generally your social security number (SSN). However, for a resident alien, sole proprietor, or disregarded entity, see the Part I instructions on page 3. For other entities, it is your employer identification number (EIN). If you do not have a number, see *How to get a TIN* on page 3.

Note. If the account is in more than one name, see the instructions for line 1 and the chart on page 4 for guidelines on whose number to enter.

<p>Social security number</p> <table border="1" style="width: 100%; border-collapse: collapse; height: 20px;"> <tr> <td style="width: 25%;"></td> <td style="width: 25%;"></td> <td style="width: 25%;"></td> <td style="width: 25%;"></td> </tr> </table> <p style="text-align: center;">or</p> <p>Employer identification number</p> <table border="1" style="width: 100%; border-collapse: collapse; height: 20px;"> <tr> <td style="width: 25%; text-align: center;">45</td> <td style="width: 25%; text-align: center;">- 4008</td> <td style="width: 25%; text-align: center;">321</td> <td style="width: 25%;"></td> </tr> </table>					45	- 4008	321		
45	- 4008	321							

Part II Certification

Under penalties of perjury, I certify that:

- The number shown on this form is my correct taxpayer identification number (or I am waiting for a number to be issued to me); and
- I am not subject to backup withholding because: (a) I am exempt from backup withholding, or (b) I have not been notified by the Internal Revenue Service (IRS) that I am subject to backup withholding as a result of a failure to report all interest or dividends, or (c) the IRS has notified me that I am no longer subject to backup withholding; and
- I am a U.S. citizen or other U.S. person (defined below); and
- The FATCA code(s) entered on this form (if any) indicating that I am exempt from FATCA reporting is correct.

Certification instructions. You must cross out item 2 above if you have been notified by the IRS that you are currently subject to backup withholding because you have failed to report all interest and dividends on your tax return. For real estate transactions, item 2 does not apply. For mortgage interest paid, acquisition or abandonment of secured property, cancellation of debt, contributions to an individual retirement arrangement (IRA), and generally, payments other than interest and dividends, you are not required to sign the certification, but you must provide your correct TIN. See the instructions on page 3.

Sign Here	<p>Signature of U.S. person ▶ Michael A. J.</p>	<p>Date ▶ 1/18/21</p>
------------------	--	--

General Instructions

Section references are to the Internal Revenue Code unless otherwise noted.

Future developments. Information about developments affecting Form W-9 (such as legislation enacted after we release it) is at www.irs.gov/fw9.

Purpose of Form

An individual or entity (Form W-9 requester) who is required to file an information return with the IRS must obtain your correct taxpayer identification number (TIN) which may be your social security number (SSN), individual taxpayer identification number (ITIN), adoption taxpayer identification number (ATIN), or employer identification number (EIN), to report on an information return the amount paid to you, or other amount reportable on an information return. Examples of information returns include, but are not limited to, the following:

- Form 1099-INT (interest earned or paid)
- Form 1099-DIV (dividends, including those from stocks or mutual funds)
- Form 1099-MISC (various types of income, prizes, awards, or gross proceeds)
- Form 1099-B (stock or mutual fund sales and certain other transactions by brokers)
- Form 1099-S (proceeds from real estate transactions)
- Form 1099-K (merchant card and third party network transactions)

- Form 1098 (home mortgage interest), 1098-E (student loan interest), 1098-T (tuition)
- Form 1099-C (canceled debt)
- Form 1099-A (acquisition or abandonment of secured property)

Use Form W-9 only if you are a U.S. person (including a resident alien), to provide your correct TIN.

If you do not return Form W-9 to the requester with a TIN, you might be subject to backup withholding. See What is backup withholding? on page 2.

By signing the filled-out form, you:

- Certify that the TIN you are giving is correct (or you are waiting for a number to be issued),
- Certify that you are not subject to backup withholding, or
- Claim exemption from backup withholding if you are a U.S. exempt payee. If applicable, you are also certifying that as a U.S. person, your allocable share of any partnership income from a U.S. trade or business is not subject to the withholding tax on foreign partners' share of effectively connected income, and
- Certify that FATCA code(s) entered on this form (if any) indicating that you are exempt from the FATCA reporting, is correct. See *What is FATCA reporting?* on page 2 for further information.

Job No.: _____

TAX FORM/DEBT/RESIDENCE CERTIFICATION
(for Advertised Projects)

Taxpayer Identification Number (T.I.N.): 45-4008321

Company Name submitting Bid/Proposal: TXAT LLC

Mailing Address: 3200 Kirby DR Suite 801, Houston TX 77098

Are you registered to do business in the State of Texas? Yes No

If you are an individual, list the names and addresses of any partnership of which you are a general partner or any assumed name(s) under which you operate your business

I. **Property:** List all taxable property in Fort Bend County owned by you or above partnerships as well as any d/b/a names. Include real and personal property as well as mineral interest accounts. (Use a second sheet of paper if necessary.)

<u>Fort Bend County Tax Acct. No.*</u>	<u>Property address or location**</u>

* This is the property account identification number assigned by the Fort Bend County Appraisal District.

** For real property, specify the property address or legal description. For business personal property, specify the address where the property is located. For example, office equipment will normally be at your office, but inventory may be stored at a warehouse or other location.

II. **Fort Bend County Debt** - Do you owe any debts to Fort Bend County (taxes on properties listed in I above, tickets, fines, tolls, court judgments, etc.)?

Yes No If yes, attach a separate page explaining the debt.

III. **Residence Certification** - Pursuant to Texas Government Code §2252.001 *et seq.*, as amended, Fort Bend County requests Residence Certification. §2252.001 *et seq.* of the Government Code provides some restrictions on the awarding of governmental contracts; pertinent provisions of §2252.001 are stated below:

- (3) "Nonresident bidder" refers to a person who is not a resident.
- (4) "Resident bidder" refers to a person whose principal place of business is in this state, including a contractor whose ultimate parent company or majority owner has its principal place of business in this state.

I certify that TXAT LLC is a Resident Bidder of Texas as defined in Government Code §2252.001.
[Company Name]

I certify that _____ is a Nonresident Bidder as defined in Government Code §2252.001 and our principal place of business is _____.
[Company Name] [City and State]

**Amended 1/05/21
Fort Bend County Pricing Form
Bid 21-046
Purchase of Ammunition**

Term: April 1, 2021 through March 31, 2022

Vendor Name: TXAT LLC

Description (no substitute)	Lawson Number	Rounds per Box	Bid Price per Box	Rounds per Case	Bid Price per Case	Number of Delivery Days	Number of Cases Purchased in 2020 Budget Year
		(only 4 decimal places are permitted)					
9.1: .223 HORNADY TAP 80265 75 GR. Manufacturer: HORNADY No Sub	12945				No Bid		NA
9.2: .223 HORNADY TAP 83278 55 GR. FPD Manufacturer: HORNADY No Sub					No Bid		NA
9.3: .223 REM, L223R3 55 GR. MC Manufacturer: REMINGTON No Sub	12946				No Bid		500
9.4: 9-MM Luger L9MM3 115 GR. MC Manufacturer: REMINGTON No Sub	12947				No Bid		165
9.5: 9-MM Luger L9MM2, 23718 124 GR. FMJ Manufacturer: REMINGTON							NA
9.6: 9-MM GS9MMB Manufacturer: REMINGTON							51

Please note that the Excel Sheet on the website would not display data in the cells. All information filled in. Fresh Drive is included.

Robin. Eaves.
TXAT. LE.
Sales

Vendor Name:

TXAT LLC

Description (no substitute)	Lawson Number	Rounds per Box	Bid Price per Box	Rounds per Case	Bid Price per Case	Number of Delivery Days	Number of Cases Purchased in 2020 Budget Year
(only 4 decimal places are permitted)							
9.7: 9-MM Luger TP, 29351, GSB9MMD 124 Manufacturer: REMINGTON No Sub					No Bid		NA
9.8: .40 S & W L40SW3 180 GR. MC Manufacturer: REMINGTON No Sub	12949				No Bid		3
9.9: .40 Golden Saber GS40SWB 180 GR. Manufacturer: REMINGTON No Sub	12950				No Bid		1
9.10: .357 SIG GSB357SB Golden Saber 357 SIG 125GR BJHP Manufacturer: REMINGTON No Sub	12951				No Bid		1
9.11: .357 SIG L357S1 UMC 125GR MC Manufacturer: REMINGTON No Sub	12952				No Bid		1
9.12: 38 SPL L38S11 130 GR. MC Manufacturer: REMINGTON No Sub	12953				No Bid		20
9.13: 38 SPL L38S11 158 GR., LRN, L3855, Manufacturer: REMINGTON No Sub					No Bid		NA
9.14: 45 Auto L45AP4 UMC 45 ACP 230GR. MC Manufacturer: REMINGTON No Sub	12954				No Bid		1

Vendor Name:

TXAT LLC

Description (no substitute)	Lawson Number	Rounds per Box	Bid Price per Box	Rounds per Case	Bid Price per Case	Number of Delivery Days	Number of Cases Purchased in 2020 Budget Year
(only 4 decimal places are permitted)							
9.15: 45 Auto GS45APB Manufacturer: REMINGTON No Sub	12955				No Bid		1
9.16: 12 GA. RR12BK8- 00 2 3/4" Buckshot 8 pellets reduced recoil Manufacturer:	12956				No Bid		NA

REMINGTON No Sub							
9.17: 308 win. #80965, 168GR, A-MAX Tap Manufacturer: HORNADY No Sub					No Bid		NA
9.18: 308 win. #80715, 168GR, ELD Tap AR Manufacturer: HORNADY No Sub					No Bid		NA
9.19: 12 GA. RR12RSB 12 GA 2 3/4" Foster slug reduced recoil Manufacturer: REMINGTON No Sub	12957				No Bid		NA

TXAT LLC
Houston TX

Vendor Name:

TXAT LLC

Description (no substitute)	Lawson Number	Rounds per Box	Bid Price per Box	Rounds per Case	Bid Price per Case	Number of Delivery Days	Number of Cases Purchased in 2020 Budget Year
(only 4 decimal places are permitted)							
9.20: 12 GA. GC127 2 3/4" 7 1/2 target loads Manufacturer: REMINGTON No Sub	12959				No Bid		NA
9.21: R30301 Core-Lokt, 30-30 win. 150 gr. SPCL. Manufacturer: REMINGTON No Sub	12960				No Bid		NA
9.22: Blank Popper, Winchester 12 GA. 2 3/4" smokeless power Manufacturer: WINCHESTER No Sub	12961				No Bid		NA

Vendor Name:

TXAT LLC

Description	Lawson Number	Rounds per Box	Bid Price per Box	Rounds per Case	Bid Price per Case	Number of Delivery Days	Number of Cases Purchased in 2020 Budget Year
(only 4 decimal places are permitted)							
9.23: .223 HORNADY TAP 80265 75 GR. HORNADY or Equal	12962				No BID		NA
9.24: .223 HORNADY TAP 83278 55 GR. FPD HORNADY or Equal	12963				No BID		NA
9.25: .223 REM, L223R3 55 GR. MC REMINGTON or Equal	12964	50	\$17.52	1000	\$350.40	60 days ARO	NA
Aquila 1E223110							
9.26: 9-MM Luger L9MM3 115 GR. MC REMINGTON or Equal	12965	50	\$9.87	1000	\$197.40	60 days ARO	NA
Aquila 1E097704							
9.27: 9-MM Golden Saber GS9MMB 124 GR. BJHP REMINGTON or Equal	12966				No BID		NA
9.28: .40 S & W L40SW3 180 GR. MC REMINGTON or Equal	12967	50	\$13.73	1000	\$274.60	60 days ARO	NA
Aquila 1E402110							
9.29: .40 Golden Saber GS40SWB 180 GR. REMINGTON or Equal	12968				No BID		NA

Vendor Name:

Description	Lawson Number	Rounds per Box	Bid Price per Box	Rounds per Case	Bid Price per Case	Number of Delivery Days	Number of Cases Purchased in 2020 Budget Year
9.30: .357 SIG GSB357SB Golden Saber 357 SIG 125GR BJHP REMINGTON or Equal	12969				No Bid		NA
9.31: .357 SIG L357S1 UMC 125GR MC REMINGTON or Equal	12970				No Bid		NA
9.32: 38 SPL L38S11 130 GR. MC REMINGTON or Equal <i>Aquila 1E382521</i>	12971	50	\$ 15.26	1000	\$ 305.20	60 days ARO	NA
9.33: 45 Auto L45AP4 UMC 45 ACP 230GR. MC REMINGTON or Equal <i>Aquila 1E452110</i>	12972	50	\$ 15.36	1000	\$ 307.20	60 days ARO	NA
9.34: 45 Auto GS45APB REMINGTON or Equal	12973				No Bid		NA
9.35: 12 GA. RR12BK8- 00 2 3/4" Buckshot 8 pellets reduced recoil REMINGTON or Equal	12974				No Bid		NA
9.36: 12 GA. RR12RSB 12 GA 2 3/4" Foster slug reduced recoil REMINGTON or Equal	12975				No Bid		NA

Vendor Name:

Description	Lawson Number	Bid Price per Round	Bid Price per Box	Bid Price per Case	Rounds per Case	Number of Delivery Days	Number of Cases Purchased in 2020 Budget Year
(only 4 decimal places are permitted)							
9.37: 12 GA. GC127 2 3/4" 7 1/2 target loads REMINGTON or Equal	12976	.206	\$5.16	\$51.60	250	60 days ARO	NA
Aquila 1CHB1357							
9.38: R30301 Core-Lokt, 30-30 win. 150 gr. SPCL. REMINGTON or Equal	12977			No. Bid			NA
9.39: Blank Popper, Winchester 12 GA. 2 3/4" smokeless power REMINGTON or Equal	12978			No. Bid			NA

CERTIFICATE OF INTERESTED PARTIES

FORM **1295**

1 of 1

Complete Nos. 1 - 4 and 6 if there are interested parties.
Complete Nos. 1, 2, 3, 5, and 6 if there are no interested parties.

**OFFICE USE ONLY
CERTIFICATION OF FILING**

Certificate Number:
2021-705179

Date Filed:
01/12/2021

Date Acknowledged:
02/09/2021

1 Name of business entity filing form, and the city, state and country of the business entity's place of business.
Precision Delta Corporation
Ruleville, MS United States

2 Name of governmental entity or state agency that is a party to the contract for which the form is being filed.
Fort Bend County

3 Provide the identification number used by the governmental entity or state agency to track or identify the contract, and provide a description of the services, goods, or other property to be provided under the contract.
B21-046
Ammunition

4	Name of Interested Party	City, State, Country (place of business)	Nature of interest (check applicable)	
			Controlling	Intermediary

5 Check only if there is NO Interested Party.

6 UNSWORN DECLARATION

My name is _____, and my date of birth is _____.

My address is _____, _____, _____, _____, _____.
(street) (city) (state) (zip code) (country)

I declare under penalty of perjury that the foregoing is true and correct.

Executed in _____ County, State of _____, on the _____ day of _____, 20____.
(month) (year)

Signature of authorized agent of contracting business entity
(Declarant)

CERTIFICATE OF INTERESTED PARTIES

FORM 1295

1 of 1

Complete Nos. 1 - 4 and 6 if there are interested parties.
Complete Nos. 1, 2, 3, 5, and 6 if there are no interested parties.

**OFFICE USE ONLY
CERTIFICATION OF FILING**

Certificate Number:
2021-712860

Date Filed:
02/02/2021

Date Acknowledged:
02/09/2021

1 Name of business entity filing form, and the city, state and country of the business entity's place of business.
TXAT LLC
Houston, TX United States

2 Name of governmental entity or state agency that is a party to the contract for which the form is being filed.
Fort Bend County

3 Provide the identification number used by the governmental entity or state agency to track or identify the contract, and provide a description of the services, goods, or other property to be provided under the contract.
B21-046
Ammunition

4	Name of Interested Party	City, State, Country (place of business)	Nature of interest (check applicable)	
			Controlling	Intermediary
	TXAT LLC	Houston, TX United States	X	

5 Check only if there is NO Interested Party.

6 UNSWORN DECLARATION

My name is _____, and my date of birth is _____.

My address is _____, _____, _____, _____, _____.
(street) (city) (state) (zip code) (country)

I declare under penalty of perjury that the foregoing is true and correct.

Executed in _____ County, State of _____, on the _____ day of _____, 20____.
(month) (year)

Signature of authorized agent of contracting business entity
(Declarant)