

**Fort Bend County Tabulation
Bid 20-099
X-Ray Equipment for Employee Clinic**

**Recommendation: VXS Imaging, Inc.
(funding: Employee Health Clinic)**

Company	Unit Bid Price	Form 1295
VXS Imaging, Inc., Stafford, TX	\$49,500.00	Yes
Mid-South Medical Imaging, Inc., Flowood, MS	\$51,000.00	
Ascend Imaging LLC, Springfield, VA	\$57,057.00	
Salus Medical Products, Indianapolis, IN	\$63,445.00	
Fujifilm Medical Systems USA Inc., Lexington, MA	\$86,720.50	
Med Tech Solutions, LLC, Tulsa, OK	Disqualified: Did not provide proof of all current required insurance.	
MXR Imaging, Inc., San Diego, CA	Disqualified: Did not provide proof of insurance.	

***Addendum 1
Fort Bend County, Texas
Invitation for Bid**



***X-Ray Equipment for Employee Clinic
BID 20-099***

SUBMIT BIDS TO:

Fort Bend County
Purchasing Department
Travis Annex
301 Jackson, Suite 201
Richmond, TX 77469

Note: All correspondence must include the term "Purchasing Department" in address to assist in proper delivery.

SUBMIT NO LATER THAN:

***Tuesday, August 4, 2020
2:00 PM (Central)**

LABEL ENVELOPE:

**BID 20-099
X-RAY EQUIPMENT**

ALL BIDS MUST BE RECEIVED IN AND TIME/DATE STAMPED BY THE PURCHASING OFFICE OF FORT BEND COUNTY BEFORE THE SPECIFIED TIME/DATE STATED ABOVE.

BIDS RECEIVED AS REQUIRED WILL THEN BE OPENED AND PUBLICLY READ.

BIDS RECEIVED AFTER THE SPECIFIED TIME, WILL BE RETURNED UNOPENED.

Results will not be given by phone.
Results will be provided to bidder in writing
after Commissioners Court award.

Requests for information must be in
writing and directed to:
Cheryl Krejci, CPPB
Senior Buyer
cheryl.krejci@fortbendcountytexas.gov

Vendor Responsibilities:

- Download and complete any addendums. (Addendums will be posted on the Fort Bend County website no Later than 48 hours prior to bid opening)
- Submit response in accordance with requirements stated on the cover of this document.
- DO NOT submit responses via email or fax.

Prepared: 6/25/20
Issued: 7/12/20

COUNTY PURCHASING AGENT
Fort Bend County, Texas



Jaime Kovar
Purchasing Agent

(281) 341-8640
Fax (281) 341-8645

July 23, 2020

TO: All Prospective Bidders

RE: Addendum No. 1 – Fort Bend County Bid 20-099 – X-Ray Equipment for Employee
Clinic

Addendum 1:

Attached is addendum 1. Vendors are to include Addendum 1 with bid response. Due date has
been extended through August 4, 2020, 2:00PM.

Immediately upon your receipt of this addendum, please fill out the following information and
email this page to Jessica Carabajal at jessica.carabajal@fortbendcountytexas.gov

VXS Imaging, Inc.

Company Name

Julie Tuckett

Signature of person receiving addendum

07/24/2020

Date

If you have any questions, please contact this office.

Sincerely,

Cheryl Krejci

Cheryl Krejci
Senior Buyer



COUNTY PURCHASING AGENT
Fort Bend County, Texas

Vendor Information

Office (281) 341-8640

Jaime Kovar
 County Purchasing Agent

Legal Company Name (top line of W9)	VXS Imaging, Inc.		
Business Name (if different from legal name)			
Federal ID # or S.S. #	1-76-0488062-9	DUNS #	
Type of Business	<input type="checkbox"/> * Corporation/LLC <input type="checkbox"/> Partnership <input type="checkbox"/> Sole Proprietor/Individual <input type="checkbox"/> Tax Exempt Organization		Age in Business? 35
Publicly Traded Business	<input type="checkbox"/> * No <input type="checkbox"/> Yes Ticker Symbol _____		
Remittance Address	12503 Exchange Drive, Suite 514		
City/State/Zip	Stafford, TX 77477		
Physical Address	12503 Exchange Drive, Suite 514		
City/State/Zip	Stafford, TX 77477		
Phone/Fax Number	Phone: 281-242-9729		Fax: 281-242-9750
Contact Person	Julie Tuckett		
E-mail	julie@vxsimaging.com		
Check all that apply to the company listed above and provide certification number.	DBE-Disadvantaged Business Enterprise _____		Certification # _____
	SBE-Small Business Enterprise _____		Certification # _____
	HUB -Texas Historically Underutilized Business _____		Certification # _____
	WBE-Women's Business Enterprise _____		Certification # _____
Company's gross annual receipts	<\$500,000 _____	\$500,000-\$4,999,999 _____*	
	\$5,000,000-\$16,999,999 _____	\$17,000,000-\$22,399,999 _____	
	>\$22,400,000 _____		
NAICs codes (Please enter all that apply)	811219, 446199 423450		
Signature of Authorized Representative			
Printed Name	Julie Tuckett		
Title	Owner, President		
Date	July 22, 2020		

THIS FORM MUST BE SUBMITTED WITH THE SOLICITATION RESPONSE

1.0 GENERAL REQUIREMENTS:

- 1.1 Read this entire document carefully. Follow all instructions. You are responsible for fulfilling all requirements and specifications. Be sure you understand them.
- 1.2 General Requirements apply to all advertised bids; however, these may be superseded, whole or in part, by the scope, special requirements, specifications, special specifications or other data contained herein.
- 1.3 Governing Law: Bidder is advised that these requirements be fully governed by the laws of the State of Texas and that Fort Bend County may request and rely on advice, decisions and opinions of the Attorney General of Texas and the County Attorney concerning any portion of these requirements.
- 1.4 Governing Document: In the event of any conflict between the terms and provisions of these requirements and the specifications, the specifications govern. In the event of any conflict of interpretation of any part of this overall document, Fort Bend County's interpretation governs.
- 1.5 Bid Document Completion: Fill out, initial each page, sign, and return ONE (1) complete bid document to the Fort Bend County Purchasing Department. An authorized representative of the bidder must sign the Contract Sheet. Do not complete the date at the top of the contract sheet. The bid document must be in a sealed envelope marked with the appropriate bid number and title. The contract will be binding only when signed by the County Judge, Fort Bend County and a purchase order authorizing the item(s) desired has been issued. The use of correction fluid is not acceptable and may result in the disqualification of bid. If an error is made, the bidder must draw a line through error and initial each change. All response, typed or written, information must be clear and legible.

If a pricing form in Excel is included and posted on the County website amongst this bid document, the Vendor must download, complete and save the Excel file of the pricing form on a CD or flash drive. The Excel file on the CD or flash drive must be downloadable by the Purchasing Department in order to copy and paste the vendor's pricing to the County's tabulation. The CD or flash drive must be included in the same sealed envelope with the respondent's completed bid document along with a printed copy of the completed pricing form.

- 1.6 Bid Returns: Bidders must return completed bid document to the Fort Bend County Purchasing Department at 301 Jackson, Suite 201, Richmond, Texas no later than 2:00 P.M. on the date specified. Late bids will not be accepted. Bids must be submitted in a sealed envelope, addressed as follows: Fort Bend County Purchasing Agent, Travis Annex, 301 Jackson, Suite 201, Richmond, Texas 77469.

Initials of Bidder: 

- 1.7 Addenda: No interpretation of the meaning of the drawings, specifications or other bid documents will be made to any bidder orally. All requests for such interpretations must be made in writing addressed to Cheryl Krejci, Senior Buyer, 301 Jackson, Suite 201, Richmond, Texas 77469, e-mail: cheryl.krejci@fortbendcountytexas.gov. Any and all interpretations and any supplemental instructions will be in the form of written addenda to the contract documents which will be posted on Fort Bend County's website. Addenda will **ONLY** be issued by the Fort Bend County Purchasing Agent. It is the sole responsibility of each bidder to insure receipt of any and all addenda. All addenda issued will become part of the contract documents. Bidders must sign and include addendum in the returned bid package. Deadline for submission of questions and/or clarification is **Wednesday, July 22, 2020 at 9:00 AM (CST)**. Requests received after the deadline will not be responded to due to the time constraints of this bid process.
- 1.8 Hold Harmless Agreement: Contractor indemnifies and holds Fort Bend County harmless from all claims for personal injury, death and/or property damage arising from any cause whatsoever, resulting directly or indirectly from contractor's performance. Contractor procures and maintains, with respect to the subject matter of this bid, appropriate insurance coverage including, as a minimum, public liability and property damage with adequate limits to cover contractor's liability as may arise directly or indirectly from work performed under terms of this bid. Certification of such coverage must be provided to the County upon request.
- 1.9 Waiver of Subrogation: Bidder and bidder's insurance carrier waive any and all rights whatsoever with regard to subrogation against Fort Bend County as an indirect party to any suit arising out of personal or property damages resulting from bidder's performance under this agreement.
- 1.10 Severability: If any section, subsection, paragraph, sentence, clause, phrase or word of these requirements or the specifications be held invalid, such holding does not affect the remaining portions of these requirements and the specifications and it is hereby declared that such remaining portions would have been included in these requirements and the specifications as though the invalid portion had been omitted.
- 1.11 Bonds: If this bid requires submission of bid guarantee and performance bond, there will be a separate page explaining those requirements. Bids submitted without the required bid bond or cashier's checks are not acceptable. Bond/s or cashier's check must be complete with all required signatures.
- 1.12 Taxes: Fort Bend County is exempt from all federal excise, state and local taxes unless otherwise stated in this document. Fort Bend County claims exemption from all sales and/or use taxes under Chapter 20, Title 122a, Vernon's Texas Civil Statutes, as amended. Texas Limited Sales Tax Exemption Certificates will be furnished upon written request to the Fort Bend County Purchasing Department.

Initials of Bidder: 

- 1.13 Fiscal Funding: A multi-year lease or lease/purchase arrangement (if requested by the specifications), or any contract continuing as a result of an extension option, must include fiscal funding out. If, for any reason, funds are not appropriated to continue the lease or contract, said lease or contract becomes null and void. After expiration of the lease, leased equipment will be removed by the bidder from the using department without penalty of any kind or form to Fort Bend County. All charges and physical activity related to delivery, installation, removal and redelivery are be the responsibility of the bidder.
- 1.14 Pricing: Prices for all goods and/or services are firm for the duration of this contract and are stated in the bid spreadsheet. Prices are all inclusive. No price changes, additions, or subsequent qualifications will be honored during the course of the contract. All prices must be written in ink or typewritten. Pricing on all transportation, freight, and other charges are to be prepaid by the contractor and included in the bid prices. If there are any additional charges of any kind, other than those mentioned above, specified or unspecified, bidder MUST indicate the items required and attendant costs or forfeit the right to payment for such items.
- 1.15 Silence of Specifications: The apparent silence of specifications as to any detail, or the apparent omission from it of a detailed description concerning any point, shall be regarded as meaning that only the best commercial practice is to prevail and that only material and workmanship of the finest quality are to be used. All interpretations of specifications shall be made on the basis of this statement. The items furnished under this contract shall be new, unused of the latest product in production to commercial trade and shall be of the highest quality as to materials used and workmanship. Manufacturer furnishing these items shall be experienced in design and construction of such items and shall be an established supplier of the item bid.
- 1.16 Supplemental Materials: Bidders are responsible for including all pertinent product data in the returned bid package. Literature, brochures, data sheets, specification information, completed forms requested as part of the bid package and any other facts which may affect the evaluation and subsequent contract award should be included. Materials such as legal documents and contractual agreements, which the bidder wishes to include as a condition of the bid, must also be in the returned bid package. Failure to include all necessary and proper supplemental materials may be cause to reject the entire bid.
- 1.17 Material Safety Data Sheets: Under the "Hazardous Communication Act", commonly known as the "Texas Right to Know Act", a bidder must provide to Fort Bend County and using departments, with each delivery, material safety data sheets, which are, applicable to hazardous substances defined in the Act. Bidders are obligated to maintain a current, updated file in the Fort Bend County Purchasing Department. Failure of the bidder to maintain such a file will be cause to reject any bid applying thereto.

- 1.18 Name Brands: Specifications may reference name brands and model numbers. It is not the intent of Fort Bend County to restrict these bids in such cases, but to establish a desired quality level of merchandise or to meet a pre-established standard due to like existing items. Bidders may offer items of equal stature and the burden of proof of such stature rests with them. Fort Bend County shall act as sole judge in determining equality and acceptability of products offered.
- 1.19 Color Selection: Determination of colors of materials is a right reserved by the using department unless otherwise specified in the bid. Unspecified colors shall be quoted as standard colors, not colors, which require up charges or special handling. Unspecified fabrics or vinyl should be construed as medium grade. If bidder fails to get color/material approvals prior to delivery of merchandise, the using department may refuse to accept the items and demand correct shipment without penalty, subject to other legal remedies.
- 1.20 Term Contracts: If the Contract is intended to cover a specific time period, said time will be given in the specifications under scope.
- 1.21 Recycled Materials: Fort Bend County encourages the use of products made of recycled materials and shall give preference in purchasing to products made of recycled materials if the products meet applicable specifications as to quantity and quality. Fort Bend County will be the sole judge in determining product preference application.
- 1.22 Evaluation: Evaluation shall be used as a determinant as to which bid items or services are the most efficient and/or most economical for Fort Bend County. It shall be based on all factors which have a bearing on price and performance of the items in the user environment. All bids are subject to tabulation by the Fort Bend County Purchasing Department and recommendation to Fort Bend County Commissioners Court. Compliance with all bid requirements, delivery and needs of the using department are considerations in evaluating bids. Pricing is NOT the only criteria for making a recommendation. The Fort Bend County Purchasing Department reserves the right to contact any bidder, at any time, to clarify, verify or request information with regard to any bid.
- 1.23 Inspections: Fort Bend County reserves the right to inspect any item(s) or service location for compliance with specifications and requirements and needs of the using department. If a bidder cannot furnish a sample of a bid item, where applicable, for review, or fails to satisfactorily show an ability to perform, the County can reject the bid as inadequate.
- 1.24 Testing: Fort Bend County reserves the right to test equipment, supplies, material and goods bid for quality, compliance with specifications and ability to meet the needs of the user. Demonstration units must be available for review. Should the goods or services fail to meet requirements and/or be unavailable for evaluation, the bid is subject to rejection.

- 1.25 Disqualification of Bidder: Upon signing this bid document, a bidder offering to sell supplies, materials, services, or equipment to Fort Bend County certifies that the bidder has not violated the antitrust laws of this state codified in section 15.01, et seq., Business & Commerce Code, or the federal antitrust laws, and has not communicated directly or indirectly the bid made to any competitor or any other person engaged in such line of business. Any or all bids may be rejected if Fort Bend County believes that collusion exists among the bidders. Bids in which the prices are obviously unbalanced may be rejected. If multiple bids are submitted by a bidder and after the bids are opened, one of the bids is withdrawn, the result will be that all of the bids submitted by that bidder will be withdrawn; however, nothing herein prohibits a vendor from submitting multiple bids for different products or services.
- 1.26 Awards: Fort Bend County reserves the right to award this Contract on the basis of lowest and best bid in accordance with the laws of the State of Texas, to waive any formality or irregularity, to make awards to more than one bidder, to reject any or all bids. In the event the lowest dollar bidder meeting specifications is not awarded a contract, the bidder may appear before the Commissioners Court and present evidence concerning its responsibility.
- 1.27 Term Contracts: If the contract is intended to cover a specific time period, said time will be given in the specifications under scope.
- 1.28 Maintenance: Maintenance required for equipment bid should be available in Fort Bend County by a manufacturer authorized maintenance facility. Costs for this service shall be shown on the bid sheet as requested or on a separate sheet, as required. If Fort Bend County opts to include maintenance, it shall be so stated in the purchase order and said cost will be included. Service will commence only upon expiration of applicable warranties and should be priced accordingly.
- 1.29 Contract Obligation: Fort Bend County Commissioners Court must award the Contract and the County Judge or other person authorized by the Fort Bend County Commissioners Court must sign the Contract before it becomes binding on Fort Bend County or the bidders. Department heads are not authorized to sign agreements for Fort Bend County. Binding agreements shall remain in effect until all products and/or services covered by this purchase have been satisfactorily delivered and accepted.
- 1.30 Title Transfer: Title and Risk of Loss of goods shall not pass to Fort Bend County until Fort Bend County actually receives and takes possession of the goods at the point or points of delivery. Receiving times may vary with the using department. Generally, deliveries may be made between 8:30 a.m. and 4:00 p.m., Monday through Friday. Bidders are advised to consult the using department for instructions. The place of delivery shall be shown under the "Special Requirement" section of this bid document and/or on the Purchase Order as a "Ship To:" address.

- 1.31 **Purchase Order and Delivery:** The successful bidder shall not deliver products or provide services without a Fort Bend County Purchase Order, signed by an authorized agent of the Fort Bend County Purchasing Department. The fastest, most reasonable delivery time shall be indicated by the bidder in the proper place on the bid sheet. Any special information concerning delivery should also be included, on a separate sheet, if necessary. All items will be shipped F.O.B. inside delivery unless otherwise stated in the specifications. This shall be understood to include bringing merchandise to the appropriate room or place designated by the using department. Every tender or delivery of goods must fully comply with all provisions of these requirements and the specifications including time, delivery and quality. Nonconformance shall constitute a breach, which must be rectified prior to expiration of the time for performance. Failure to rectify within the performance period will be considered cause to reject future deliveries and cancellation of the contract by Fort Bend County without prejudice to other remedies provided by law. Where delivery times are critical, Fort Bend County reserves the right to award accordingly.
- 1.32 **Contract Extension:** Extensions may be made only by written agreement between Fort Bend County and the bidder. Any price escalations are limited to those stated by the bidder in the original bid.
- 1.33 **Termination:** Fort Bend County reserves the right to terminate the contract for default if Seller breaches any of the terms therein, including warranties of bidder or if the bidder becomes insolvent or commits acts of bankruptcy. Such right of termination is in addition to and not in lieu of any other remedies, which Fort Bend County may have in law or equity. Default may be construed as, but not limited to, failure to deliver the proper goods and/or services within the proper amount of time, and/or to properly perform any and all services required to Fort Bend County's satisfaction and/or to meet all other obligations and requirements. Contracts may be terminated without cause upon thirty (30) days written notice to either party unless otherwise specified.
- 1.34 **Recycled Materials:** Fort Bend County encourages the use of products made of recycled materials and shall give preference in purchasing to products made of recycled materials if the products meet applicable specifications as to quantity and quality. Fort Bend County will be the sole judge in determining product preference application.
- 1.35 **Interlocal Participation:** Additional governmental entities may purchase from this bid. Vendor agrees to accept purchase orders from those participating entities and to invoice each entity separately.
- 1.36 **Modifications:** This instrument contains the entire Contract between the parties relating to the rights herein granted and obligations herein assumed. Any oral or written representations or modifications concerning this instrument shall be of no force and effect excepting a subsequent written modification signed by both

parties hereto.

2.0 TERMS & CONDITIONS:

- 2.1 Seller to Package Goods: Seller will package goods in accordance with good commercial practice. Each delivery container shall be clearly and permanently marked as follows (a) Seller's name and address; (b) Consignee's name, address and purchase order number and the bid number if applicable; (c) Container number and total number of containers (e.g. box 1 of 4 boxes); and (d) the number of the container bearing the packing slip. Seller shall bear cost of packaging unless otherwise provided. Goods shall be suitably packed to secure lowest transportation costs and to conform to requirements of common carriers and any applicable specifications. Fort Bend County's count or weight shall be final and conclusive on shipments not accompanied by packing list.
- 2.2 Shipment Under Reservation Prohibited: Seller is not authorized to ship goods under reservation and no tender of a bill of lading will operate as a tender of goods.
- 2.3 Title and Risk of Loss: The title and risk of loss of the goods shall not pass to the County until a County employee actually receives and takes possession of the goods at the point or points of delivery.
- 2.4 Delivery Terms: F.O.B. Destination Freight Prepaid, Inside Delivery, unless delivery terms are specified otherwise on Purchase Order.
- 2.5 No Replacement of Defective Tender: Every tender or delivery of goods must fully comply with all provisions of the Purchase Order as to time of delivery, quality and the like. If a tender is made which does not fully conform, this shall constitute a breach and Seller shall not have the right to substitute a conforming tender.
- 2.6 Place of Delivery: The place of delivery shall be that set forth in the block of the purchase order entitled "Ship To". Any change thereto shall be effective by modification as provided for in Clause number 2.20 "Modifications", hereof. The terms of this agreement are "no arrival, no sale", at the discretion of Fort Bend County.
- 2.7 Invoices and Payments:
- 2.7.1 Seller shall submit separate invoices, in duplicate. Invoices shall indicate the purchase order number and the bid number if applicable. Invoices shall be itemized and transportation charges, if any, shall be listed separately. A copy of the bill of lading, and the freight waybill when applicable should be attached to the invoice.
- 2.7.2 Fort Bend County's obligation is payable only and solely from funds

Initials of Bidder: 

available for the purpose of this purchase. Lack of funds shall render the order null and void to the extent funds are not available and any delivered but unpaid goods will be returned to Seller by the county.

- 2.7.3 Do not include Federal Excise, State, or City Sales Tax. Fort Bend County is a tax-exempt governmental entity.
- 2.8 Gratuities: Fort Bend County may, by written notice to the Seller, cancel any order without liability, if it is determined by the County that gratuities, in the form of entertainment, gifts, or otherwise were offered or given by the Seller, or any agent or representative of the Seller to any officer or employee of Fort Bend County with a view toward securing an order. In the event an order is canceled by the County pursuant to this provision, the County shall be entitled, in addition to any other rights and remedies, to recover or withhold the amount of the cost incurred by Seller in providing such gratuities.
- 2.9 Special Tools and Test Equipment: If the price stated on the face of an order includes the cost of any special tooling or special test equipment fabricated or required by Seller for the purpose of filing this order, such special tooling equipment and any process sheets related thereto shall become the property of the County and to the extent feasible shall be identified by the Seller as such.
- 2.10 Warranty/Price:
- 2.10.1 The price to be paid by the County shall be that contained in Seller's quote or bid which Seller warrants to be no higher than Seller's current prices on orders by others for products of the kind and specification covered by an order for similar quantities under similar or like conditions and methods of purchase. In the event Seller breaches this warranty the prices of the items shall be reduced to the Seller's current prices on orders by others. Fort Bend County may cancel this contract without liability.
- 2.10.2 The Seller warrants that no person or selling agency has been employed or retained to solicit or secure any County order based upon any agreement or understanding for commission, percentage, brokerage, or contingent fee excepting bona fide employees of bona fide established commercial or selling agencies maintained by the Seller for the purpose of securing business. A breach or violation of this warranty gives the County the right, in addition to any other right or rights, to cancel this contract without liability.
- 2.11 Warranty Product: Seller shall not limit or exclude any implied warranties and any attempt to do so shall render an order voidable at the option of the County. Seller warrants that the goods furnished will conform to the specifications, drawings, and description listed in the bid invitation and purchase order as applicable, and to the sample(s) furnished by Seller if any. In the event of a

Initials of Bidder: 

conflict between the specifications, drawings, and descriptions, the specifications shall govern.

- 2.12 **Safety Warranty:** Seller warrants that the product sold to Fort Bend County shall conform to the standards promulgated by the U.S. Department of Labor under the Occupational Safety and Health Act of 1970. In the event the product does not conform to OSHA standards, the County may return the product for correction or replacement at the Seller's expense. In the event Seller fails to make the appropriate correction within 10 days, correction made by the County will be at Seller's expense.
- 2.13 **No Warranty by Fort Bend County Against Infringements:** As part of a contract for sale Seller agrees to ascertain whether goods manufactured in accordance with the specifications will give rise to the rightful claim of any third person by way of infringement. Fort Bend County makes no warranty that the production of goods according to the specification will not give rise to such a claim and in no event shall Fort Bend County be liable to Seller for indemnification in the event the Seller is sued on the grounds of infringement or the like. If Seller is of the opinion that an infringement will result, he will notify Fort Bend County to this effect in writing within two days after the receiving Purchase Order. If the County does not receive notice and is subsequently held liable for the infringement, Seller will defend and save the County harmless. If Seller in good faith ascertains that production of the goods in accordance with the specifications will result in infringement, this contract shall be null and void except that the County will pay Seller the reasonable cost of his search as to infringements.
- 2.14 **Right of Inspection:** The County shall have the right to inspect the goods at delivery before accepting them.
- 2.15 **Cancellation:** Fort Bend County shall have the right to cancel for default all or any part of the undelivered portion of an order if Seller breaches any of the terms hereof including warranties of Seller, or if the Seller becomes insolvent or files for protection under the bankruptcy laws. Such rights of cancellation are in addition to and not in lieu of any other remedies, which Fort Bend County may have in law or equity.
- 2.16 **Termination:** The performance of work under a Purchase Order may be terminated in whole or in part by the County in accordance with this provision. Termination of work there under shall be effected by the delivery to the Seller of a "Notice of Termination" specifying the extent to which performance of work under the order is terminated and the date upon which such termination becomes effective. Such right of termination is in addition to and not in lieu of rights of Fort Bend County set forth in Clause 15 herein.
- 2.17 **Force Majeure:** Force Majeure means a delay encountered by a party in the performance of its obligations under this Agreement, which is caused by an event

Initials of Bidder: 

beyond the reasonable control of that party. Without limiting the generality of the foregoing, "Force Majeure" shall include but not be restricted to the following types of events: acts of God or public enemy; acts of governmental or regulatory authorities; fires, floods, epidemics or serious accidents; unusually severe weather conditions; strikes, lockouts, or other labor disputes; and defaults by subcontractors.

In the event of a Force Majeure, the affected party shall not be deemed to have violated its obligations under this Agreement, and the time for performance of any obligations of that party shall be extended by a period of time necessary to overcome the effects of the Force Majeure, provided that the foregoing shall not prevent this Agreement from terminating in accordance with the termination provisions. If any event constituting a Force Majeure occurs, the affected party shall notify the other parties in writing, within twenty-four (24) hours, and disclose the estimated length of delay, and cause of the delay.

- 2.18 Assignment-Delegation: No right or interest in an order shall be assigned or delegation of any obligation made by Seller without the written permission of Fort Bend County. Any attempted assignment or delegation by Seller shall be wholly void and totally ineffective for all purposes unless made in conformity with this paragraph.
- 2.19 Waiver: No claim or right arising out of a breach of any contract can be discharged in whole or in part by a waiver or renunciation of the claim or right unless the waived or renunciation is supported by consideration and is in writing signed by the aggrieved party.
- 2.20 Modification: A Purchase Order can be modified or rescinded only by a writing signed by both of the parties or their duly authorized agents.
- 2.21 Parol Evidence: This writing is intended by the parties as a final expression of their agreement and is intended also as a complete and exclusive statement of the terms of this agreement. No course of prior dealings between the parties and no usage of the trade shall be relevant to supplement or explain any terms rendered under this agreement and shall not be relevant to determine the meaning of this agreement even though the accepting or acquiescing party has knowledge of the performance and opportunity for objection. Whenever a term defined by the Uniform Commercial Code is used in this agreement, the definition contained in the Code is to control.
- 2.22 Applicable Law: This agreement shall be governed by the Uniform Commercial Code. Whenever the term "Uniform Commercial Code" is used it shall be construed as meaning the Uniform Commercial Code as adopted in the State of Texas and in effective on the date of the purchase order.
- 2.23 Advertising: Seller shall not advertise or publish, without the County's prior

Initials of Bidder: 

consent the fact that Fort Bend County has entered into any contract, except to the extent necessary to comply with proper requests for information from an authorized representative of the federal, state, or local government.

- 2.24 **Right to Assurance:** Whenever the County in good faith has reason to question the other party's intent to perform. The County may demand that the other party give written assurance of his intent to perform. In the event that a demand is made and no assurance is given within five (5) days, the County may treat this failure as an anticipatory repudiation of the contract.
- 2.25 **Venue:** Both parties agree that venue for any litigation arising from this contract shall lie in Richmond, Fort Bend County, Texas.
- 2.26 **Prohibition Against Personal Interest in Contracts:** No officer or employee of the County shall have a financial interest, direct or indirect, in any contract with the County, or shall be financially interested, directly or indirectly, in the sale to the County of any land, materials, supplies, or service, except on behalf of the County as an officer or employee. Any willful violation of this section shall constitute malfeasance in office, and any officer or employee guilty thereof shall be subject to disciplinary action under applicable laws, statutes and codes of the State of Texas. Any violation of this section, with the knowledge, expressed or implied of the person or corporation contracting with the County shall render the contract involved voidable by the County Commissioners Court.

3.0 SCOPE:

It is the intent of Fort Bend County to contract with one (1) vendor to provide and install x-ray equipment for Fort Bend County, as specified herein.

4.0 PRE-BID CONFERENCE:

A pre-bid conference will be conducted on **Tuesday, July 21, 2020 at 8:30AM** (central). The pre-bid conference will be held at the Fort Bend County Purchasing Department located in the Travis Annex at 301 Jackson, Suite 201, Richmond, Texas 77469, with a walk-through immediately following, (if needed). All bidders are encouraged to attend as this is the only date and time to view the site.

5.0 INSURANCE:

- 5.1 All respondents must submit, with response, a current certificate of insurance indicating coverage in the amounts stated below. In lieu of submitting a certificate of insurance, respondents may submit, with response, a notarized statement from an Insurance company, authorized to conduct business in the State of Texas, and acceptable to Fort Bend County, guaranteeing the issuance of an insurance policy, with the coverage stated below, to the firm named therein, if

successful, upon award of this Contract. Failure to provide current insurance certificate or notarized statement will result in disqualification of submittal.

- 5.2 At contract execution, contractor shall furnish County with properly executed certificates of insurance which shall evidence all insurance required and provide that such insurance shall not be canceled, except on 30 days prior written notice to County. Contractor shall provide certified copies of insurance endorsements and/or policies if requested by County. Contractor shall maintain such insurance coverage from the time Services commence until Services are completed and provide replacement certificates, policies and/or endorsements for any such insurance expiring prior to completion of Services. Contractor shall obtain such insurance written on an Occurrence form (or a Claims Made form for Professional Liability insurance) from such companies having Best's rating of A/VII or better, licensed or approved to transact business in the State of Texas, and shall obtain such insurance of the following types and minimum limits:
- 5.2.1 Workers' Compensation insurance. Substitutes to genuine Workers' Compensation Insurance will not be allowed.
- 5.2.2 Employers' Liability insurance with limits of not less than \$1,000,000 per injury by accident, \$1,000,000 per injury by disease, and \$1,000,000 per bodily injury by disease.
- 5.2.3 Commercial general liability insurance with a limit of not less than \$1,000,000 each occurrence and \$2,000,000 in the annual aggregate. Policy shall cover liability for bodily injury, personal injury, and property damage and products/completed operations arising out of the business operations of the policyholder.
- 5.2.4 Business Automobile Liability coverage with a combined Bodily Injury/Property Damage limit of not less than \$1,000,000 each accident. The policy shall cover liability arising from the operation of licensed vehicles by policyholder.
- 5.3 County and the members of Commissioners Court shall be named as additional insured to all required coverage except for Workers' Compensation and Professional Liability (if required). All Liability policies including Workers' Compensation written on behalf of contractor, excluding Professional Liability, shall contain a waiver of subrogation in favor of County and members of Commissioners Court.
- 5.4 If required coverage is written on a claims-made basis, contractor warrants that any retroactive date applicable to coverage under the policy precedes the effective date of the contract; and that continuous coverage will be maintained or an extended discovery period will be exercised for a period of two (2) years beginning from the time that work under the agreement is completed.

Initials of Bidder: 

- 5.5 Contractor shall not commence any portion of the work under this Contract until it has obtained the insurance required herein and certificates of such insurance have been filed with and approved by Fort Bend County.
- 5.6 No cancellation of or changes to the certificates, or the policies, may be made without sixty (60) days prior, written notification to Fort Bend County.
- 5.7 Approval of the insurance by Fort Bend County shall not relieve or decrease the liability of the Contractor.

6.0 INDEMNIFICATION:

Respondent shall save harmless County from and against all claims, liability, and expenses, including reasonable attorney's fees, arising from activities of respondent, its agents, servants or employees, performed under this agreement that result from the negligent act, error, or omission of respondent or any of respondent's agents, servants or employees.

- 6.1 Respondent shall timely report all such matters to Fort Bend County and shall, upon the receipt of any such claim, demand, suit, action, proceeding, lien or judgment, not later than the fifteenth day of each month; provide Fort Bend County with a written report on each such matter, setting forth the status of each matter, the schedule or planned proceedings with respect to each matter and the cooperation or assistance, if any, of Fort Bend County required by Respondent in the defense of each matter.
- 6.2 Respondent's duty to defend, indemnify and hold Fort Bend County harmless shall be absolute. It shall not abate or end by reason of the expiration or termination of any contract unless otherwise agreed by Fort Bend County in writing. The provisions of this section shall survive the termination of the contract and shall remain in full force and effect with respect to all such matters no matter when they arise.
- 6.3 In the event of any dispute between the parties as to whether a claim, demand, suit, action, proceeding, lien or judgment appears to have been caused by or appears to have arisen out of or in connection with acts or omissions of Respondent, Respondent shall never-the-less fully defend such claim, demand, suit, action, proceeding, lien or judgment until and unless there is a determination by a court of competent jurisdiction that the acts and omissions of Respondent are not at issue in the matter.
- 6.4 Respondent's indemnification shall cover, and Respondent agrees to indemnify Fort Bend County, in the event Fort Bend County is found to have been negligent for having selected Respondent to perform the work described in this request.
- 6.5 The provision by Respondent of insurance shall not limit the liability of Respondent under an agreement.

- 6.6 Respondent shall cause all trade contractors and any other contractor who may have a contract to perform construction or installation work in the area where work will be performed under this request, to agree to indemnify Fort Bend County and to hold it harmless from all claims for bodily injury and property damage that may arise from said Respondent's operations. Such provisions shall be in form satisfactory to Fort Bend County.
- 6.7 Loss Deduction Clause - Fort Bend County shall be exempt from, and in no way liable for, any sums of money which may represent a deductible in any insurance policy. The payment of deductibles shall be the sole responsibility of Respondent and/or trade contractor providing such insurance.

7.0 TEXAS ETHICS COMMISSION FORM 1295:

- 7.1 Effective January 1, 2016 all contracts executed by Commissioners Court, regardless of the dollar amount, will require completion of Form 1295 "Certificate of Interested Parties", per the new Government Code Statute §2252.908. All vendors submitting a response to a formal Bid, RFP, SOQ or any contracts, contract amendments, renewals or change orders are required to complete the Form 1295 online through the State of Texas Ethics Commission website. Please visit: https://www.ethics.state.tx.us/whatsnew/elf_info_form1295.htm.
- 7.2 On-line instructions:
- 7.2.1 Name of governmental entity is to read: Fort Bend County.
- 7.2.2 Identification number used by the governmental entity is: B20-099.
- 7.2.3 Description is the title of the solicitation: X-ray Equipment
- 7.3 Apparent low bidder(s) will be required to provide the Form 1295 within three (3) calendar days from notification; however, if your company is publicly traded you are not required to complete this form.

8.0 MODIFICATIONS:

This instrument contains the entire Contract between the parties relating to the rights herein granted and obligations herein assumed. Any oral or written representations or modifications concerning this instrument shall be of no force and effect excepting a subsequent written modification signed by both parties hereto.

9.0 SILENCE OF SPECIFICATIONS:

The apparent silence of specifications as to any detail, or the apparent omission from it of a detailed description concerning any point, shall be regarded as meaning that only the best commercial practice is to prevail and that only material and workmanship of the finest quality are to be used. All interpretations of specifications shall be made on the basis of this statement.

Initials of Bidder: 

The items furnished under this contract shall be new, unused of the latest product in production to commercial trade and shall be of the highest quality as to materials used and workmanship. Manufacturer furnishing these items shall be experienced in design and construction of such items and shall be an established supplier of the item bid.

10.0 SEVERABILITY:

In the event one or more of the provisions contained in these requirements or the specifications shall for any reason be held to be invalid, illegal or unenforceable in any respect, such invalidity, illegality, or unenforceability shall not affect any other provision hereof and these requirements or the specifications shall be construed as if such invalid, illegal, or unenforceable provision had never been contained herein.

11.0 GOVERNING FORMS:

In the event of any conflict between the terms and provisions of these requirements and the specifications, the specifications shall govern. In the event of any conflict of interpretation of any part of this overall document, Fort Bend County's interpretation shall govern.

12.0 TAX EXEMPT:

Fort Bend County is exempt from state and local sales and use taxes under Section 151.309 of the Texas Tax Code. This Contract is deemed to be a separate contract for Texas tax purposes, and as such, Fort Bend County hereby issues its Texas Exemption for the purchase of any items qualifying for exemption under this Contract. Contractor is to issue its Texas Resale Certificate to vendors and subcontractors for such items qualifying for this exemption, and further, contractor should state these items at cost.

13.0 ENTIRE AGREEMENT:

The Parties agree that this Contract contains all of the terms and conditions of the understanding of the parties relating to the subject matter hereof. All prior negotiations, discussions, correspondence and preliminary understandings between the parties and others relating hereto are superseded by this Contract. By entering into this Contract, the parties do not intend to create any obligations, express or implied, other than those specifically set out in this Contract.

14.0 APPLICABLE LAW AND VENUE:

This Contract shall be construed under and in accord with the laws of the State of Texas, and all obligations of the parties created hereunder are performable in Fort Bend County, Texas, and that venue for any litigation arising out of or related to this Contract shall lie solely in the court of appropriate jurisdiction located in Fort Bend County, Texas.

15.0 STATE LAW REQUIREMENTS FOR CONTRACTS:

The contents of this section are required by Texas Law and are included by County regardless of

content.

- 15.1 Agreement to Not Boycott Israel Chapter 2270 Texas Government Code: By signature on vendor form, Contractor verifies Contractor does not boycott Israel and will not boycott Israel during the term of this Contract.
- 15.2 Texas Government Code Section 2251.152 Acknowledgment: By signature on vendor form, Contractor represents pursuant to Section 2252.152 of the Texas Government Code, that Contractor is not listed on the website of the Comptroller of the State of Texas concerning the listing of companies that are identified under Section 806.051, Section 807.051 or Section 2253.153.

16.0 HUMAN TRAFFICKING:

By acceptance of this contract, Contractor acknowledges that Fort Bend County is opposed to human trafficking and that no County funds will be used in support of services or activities that violate human trafficking laws.

17.0 PERMITS:

It shall be the sole responsibility of the successful bidder to obtain all required permits in the name of Fort Bend County.

18.0 PREVAILING WAGES:

This project is subject to the prevailing wage rate requirements of Chapter 2258 of the Government Code. The Contractor shall pay Fort Bend County sixty dollars (\$60.00) for each worker employed by the Contractor for the provision of services described herein for each calendar day or part of the day that the worker is paid less than the below stated rates. Contractors may also visit <https://beta.sam.gov>.

General Decision Number: TX20200247 02/14/2020
Superseded General Decision Number: TX20190247

State: Texas
Construction Type: Building
County: Fort Bend County in Texas.

BUILDING CONSTRUCTION PROJECTS (does not include single family homes or apartments up to and including 4 stories).

Note: Under Executive Order (EO) 13658, an hourly minimum wage of \$10.80 for calendar year 2020 applies to all contracts subject to the Davis-Bacon Act for which the contract is awarded (and any solicitation was issued) on or after January 1, 2015. If this contract is covered by the EO, the contractor must pay all workers in any classification listed on this wage determination at least \$10.80 per hour (or the applicable wage rate listed on this wage determination, if it is

Initials of Bidder: 

higher) for all hours spent performing on the contract in calendar year 2020. If this contract is covered by the EO and a classification considered necessary for performance of work on the contract does not appear on this wage determination, the contractor must pay workers in that classification at least the wage rate determined through the conformance process set forth in 29 CFR 5.5(a)(1)(ii) (or the EO minimum wage rate, if it is higher than the conformed wage rate). The EO minimum wage rate will be adjusted annually. Please note that this EO applies to the above-mentioned types of contracts entered into by the federal government that are subject to the Davis-Bacon Act itself, but it does not apply to contracts subject only to the Davis-Bacon Related Acts, including those set forth at 29 CFR 5.1(a)(2)-(60). Additional information on contractor requirements and worker protections under the EO is available at www.dol.gov/whd/govcontracts.

Modification Number	Publication Date
0	01/03/2020

ASBE0022-009 06/01/2019

	Rates	Fringes
ASBESTOS WORKER/HEAT & FROST INSULATOR (Duct, Pipe and Mechanical System Insulation)	\$ 24.28	14.16
BOIL0074-003 01/01/2017		
BOILERMAKER	\$ 28.00	22.35
CARP0551-008 04/01/2016		
CARPENTER (Excludes Acoustical Ceiling Installation, Drywall Hanging, Form Work and Metal Stud Installation)	\$ 23.05	8.78
* ELEC0716-005 08/28/2019		
ELECTRICIAN (Excludes Low Voltage Wiring and Installation of Alarms)	\$ 32.25	9.24
ELEV0031-003 01/01/2019		
ELEVATOR MECHANIC	\$ 42.60	33.705

FOOTNOTES:

A. 6% under 5 years based on regular hourly rate for all hours worked. 8% over 5 years based on regular hourly rate for all hours worked.

B. Holidays: New Year's Day; Memorial Day; Independence Day; Labor Day; Thanksgiving Day; Friday after Thanksgiving Day; Christmas Day; and Veterans Day.

Initials of Bidder: 

ENGI0450-002 04/01/2014

POWER EQUIPMENT OPERATOR Cranes	\$ 34.85	9.85
------------------------------------	----------	------

IRON0084-002 06/01/2019

IRONWORKER (ORNAMENTAL AND STRUCTURAL) PLAS0079-004 01/01/2015	\$ 24.42	7.12
---	----------	------

PLASTERER	\$ 19.92	1.00
-----------	----------	------

* PLUM0068-002 10/01/2019

PLUMBER	\$ 36.15	11.04
---------	----------	-------

PLUM0211-010 10/01/2018

PIPEFITTER (Including HVAC Pipe Installation)	\$ 33.30	12.26
---	----------	-------

SHEE0054-003 07/01/2017

SHEET METAL WORKER (Excludes HVAC Duct and Unit Installation)	\$ 27.72	13.70
--	----------	-------

SUTX2014-023 07/21/2014

ACOUSTICAL CEILING MECHANIC	\$ 16.41	3.98
-----------------------------	----------	------

BRICKLAYER	\$ 19.86	0.00
------------	----------	------

CAULKER	\$ 15.36	0.00
---------	----------	------

CEMENT MASON/CONCRETE FINISHER	\$ 13.82	0.00
--------------------------------	----------	------

DRYWALL FINISHER/TAPER	\$ 16.30	3.71
------------------------	----------	------

DRYWALL HANGER AND METAL STUD INSTALLER	\$ 17.45	3.96
---	----------	------

ELECTRICIAN (Alarm Installation Only)	\$ 17.97	3.37
---------------------------------------	----------	------

ELECTRICIAN (Low Voltage Wiring Only)	\$ 18.00	1.68
---------------------------------------	----------	------

FLOOR LAYER: Carpet	\$ 20.00	0.00
---------------------	----------	------

FORM WORKER	\$ 11.87	0.00
-------------	----------	------

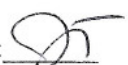
Initials of Bidder: 

GLAZIER	\$ 19.12	4.41
INSULATOR – BATT	\$ 14.87	0.73
IRONWORKER, REINFORCING	\$ 12.10	0.00
LABORER: Common or General	\$ 10.79	0.00
LABORER: Mason Tender – Brick	\$ 13.37	0.00
LABORER: Mason Tender - Cement/Concrete	\$ 10.50	0.00
LABORER: Pipelayer	\$ 12.94	0.00
LABORER: Roof Tearoff.	\$ 11.28	0.00
LABORER: Landscape and Irrigation	\$ 9.49	0.00
LATHER	\$ 19.73	0.00
OPERATOR: Backhoe/Excavator/Trackhoe	\$ 14.10	0.00
OPERATOR: Bobcat/Skid Steer/Skid Loader	\$ 13.93	0.00
OPERATOR: Bulldozer	\$ 20.77	0.00
OPERATOR: Drill	\$ 16.22	0.34
OPERATOR: Forklift	\$ 15.64	0.00
OPERATOR: Grader/Blade	\$ 13.37	0.00
OPERATOR: Loader	\$ 13.55	0.94
OPERATOR: Mechanic	\$ 17.52	3.33
OPERATOR: Paver (Asphalt, Aggregate, and Concrete)	\$ 16.03	0.00
OPERATOR: Roller	\$ 16.00	0.00
PAINTER (Brush, Roller and Spray), Excludes Drywall Finishing/Taping	\$ 16.77	4.51
ROOFER	\$ 15.40	0.00

Initials of Bidder: *GT*

SHEET METAL WORKER (HVAC Duct Installation Only)	\$ 17.81	2.64
SHEET METAL WORKER (HVAC Unit Installation Only)	\$ 16.00	1.61
SPRINKLER FITTER (Fire Sprinklers)	\$ 22.17	9.70
TILE FINISHER	\$ 12.00	0.00
TILE SETTER	\$ 16.17	0.00
TRUCK DRIVER: 1/Single Axle Truck	\$ 14.95	5.23
TRUCK DRIVER: Dump Truck	\$ 12.39	1.18
TRUCK DRIVER: Flatbed Truck	\$ 19.65	8.57
TRUCK DRIVER: Semi-Trailer Truck	\$ 12.50	0.00
TRUCK DRIVER: Water Truck	\$ 12.00	4.11
WATERPROOFER	\$ 14.39	0.00

WELDERS - Receive rate prescribed for craft performing operation to which welding is incidental.

Note: Executive Order (EO) 13706, Establishing Paid Sick Leave for Federal Contractors applies to all contracts subject to the Davis-Bacon Act for which the contract is awarded (and any solicitation was issued) on or after January 1, 2017. If this contract is covered by the EO, the contractor must provide employees with 1 hour of paid sick leave for every 30 hours they work, up to 56 hours of paid sick leave each year. Employees must be permitted to use paid sick leave for their own illness, injury or other health-related needs, including preventive care; to assist a family member (or person who is like family to the employee) who is ill, injured, or has other health-related needs, including preventive care; or for reasons resulting from, or to assist a family member (or person who is like family to the employee) who is a victim of, domestic violence, sexual assault, or stalking. Additional information on contractor requirements and worker protections under the EO is available at www.dol.gov/whd/govcontracts.

Unlisted classifications needed for work not included within the scope of the classifications listed may be added after award only as provided in the labor standards contract clauses (29CFR 5.5 (a) (1) (ii)).

The body of each wage determination lists the classification and wage rates that have been found to be prevailing for the cited type(s) of construction in the area covered by the wage determination. The classifications are listed in alphabetical order of ""identifiers"" that indicate whether the particular rate is a union rate (current union negotiated rate for local), a survey rate (weighted average rate) or a union average rate (weighted union average rate).

Initials of Bidder: 

Union Rate Identifiers

A four letter classification abbreviation identifier enclosed in dotted lines beginning with characters other than ""SU"" or ""UAVG"" denotes that the union classification and rate were prevailing for that classification in the survey. Example: PLUM0198-005 07/01/2014. PLUM is an abbreviation identifier of the union which prevailed in the survey for this classification, which in this example would be Plumbers. 0198 indicates the local union number or district council number where applicable, i.e., Plumbers Local 0198. The next number, 005 in the example, is an internal number used in processing the wage determination. 07/01/2014 is the effective date of the most current negotiated rate, which in this example is July 1, 2014.

Union prevailing wage rates are updated to reflect all rate changes in the collective bargaining agreement (CBA) governing this classification and rate.

Survey Rate Identifiers

Classifications listed under the ""SU"" identifier indicate that no one rate prevailed for this classification in the survey and the published rate is derived by computing a weighted average rate based on all the rates reported in the survey for that classification. As this weighted average rate includes all rates reported in the survey, it may include both union and non-union rates. Example: SULA2012-007 5/13/2014. SU indicates the rates are survey rates based on a weighted average

calculation of rates and are not majority rates. LA indicates the State of Louisiana. 2012 is the year of survey on which these classifications and rates are based. The next number, 007 in the example, is an internal number used in producing the wage determination. 5/13/2014 indicates the survey completion date for the classifications and rates under that identifier.

Survey wage rates are not updated and remain in effect until a new survey is conducted.

Union Average Rate Identifiers

Classification(s) listed under the UAVG identifier indicate that no single majority rate prevailed for those classifications; however, 100% of the data reported for the classifications was union data. EXAMPLE: UAVG-OH-0010 08/29/2014. UAVG indicates that the rate is a weighted union average rate. OH indicates the state. The next number, 0010 in the example, is an internal number used in producing the wage determination. 08/29/2014 indicates the survey completion date for the classifications and rates under that identifier.

A UAVG rate will be updated once a year, usually in January of each year, to reflect a weighted average of the current negotiated/CBA rate of the union locals from which the rate is based.

WAGE DETERMINATION APPEALS PROCESS

1.) Has there been an initial decision in the matter? This can be:

- * an existing published wage determination
- * a survey underlying a wage determination
- * a Wage and Hour Division letter setting forth a position on a wage determination matter

* a conformance (additional classification and rate) ruling

On survey related matters, initial contact, including requests for summaries of surveys, should be with the Wage and Hour Regional Office for the area in which the survey was conducted because those Regional Offices have responsibility for the Davis-Bacon survey program. If the response from this initial contact is not satisfactory, then the process described in 2.) and 3.) should be followed.

With regard to any other matter not yet ripe for the formal process described here, initial contact should be with the Branch of Construction Wage Determinations. Write to:

Branch of Construction Wage Determinations
Wage and Hour Division
U.S. Department of Labor
200 Constitution Avenue, N.W.
Washington, DC 20210

2.) If the answer to the question in 1.) is yes, then an interested party (those affected by the action) can request review and reconsideration from the Wage and Hour Administrator (See 29 CFR Part 1.8 and 29 CFR Part 7). Write to:

Wage and Hour Administrator
U.S. Department of Labor
200 Constitution Avenue, N.W.
Washington, DC 20210

The request should be accompanied by a full statement of the interested party's position and by any information (wage payment data, project description, area practice material, etc.) that the requestor considers relevant to the issue.

3.) If the decision of the Administrator is not favorable, an interested party may appeal directly to the Administrative Review Board (formerly the Wage Appeals Board). Write to:

Administrative Review Board
U.S. Department of Labor
200 Constitution Avenue, N.W.
Washington, DC 20210

4.) All decisions by the Administrative Review Board are final.

19.0 DELIVERY:

Delivery of the x-ray machine and installation must be completed by September 24, 2020 to Fort Bend County's Employee Health Clinic, 301 Jackson, Richmond, TX 77469, unless otherwise noted on purchase order.

20.0 SPECIFICATIONS AND BID PRICING:

Bidder is required to provide bid prices for delivery and installation of the below items or approved equals (see Section 1.18). If bidding an equal product, it is required of the bidder to provide the manufacturer name and model in the space provided. The manufacturer's detailed specifications of the equal product must be included with bidder's response as well as the specified item's detailed specifications proving the items are equal. Quantity listed below is estimated; all items may not be purchased. Fort Bend County reserves the right to purchase an increased or decreased quantity. Prices bid are all inclusive. No additional fees are permitted.

Provide and install, one (1) AmRad™ Advantage AA4 FRS System or equal with Medlink Alto DR System or equal to include the below during normal work hours of 7:00AM through 5:00PM. This item requires hardwiring.

AmRad 400S High Frequency Generator or equal:

- 25 kHz, 40 kW High Frequency (HF) generator
- mA stations: 10s to 500L
- mAs range: 0.1-630 mAs
- Operates from 1 phase, 230V electric service or 3-phase 230V or 400-480V
- Pedestal Mount

SST 3001 Floor Mount Tubestand or equal:

- Floor Mount, non-rotating Tubestand (82.25inch tall)
- 95.5 inch x 17 inch (includes travel track) floor rail assembly
- 106 inch (8 foot, 10 inch) total length
- Fixed length tube arm with manual x-ray tube rotation for centering to wallstand
- Angulation dial, operator handgrips, and electric positioning locks
- 6 inch Trunnion Tube Mount with cooling fan for x-ray tube

Receptor Stand:

- Heavy-duty Wallstand with motorized vertical travel, rotating center-mount enclosure for CR or DR applications (must specify at time of order)
- Manual rotating enclosure with angulation gauge in five (5) degree increments
- Footswitch and column button actuation for motorized vertical travel
- Grid Cabinet, 18 inch x 18 only
- 10:1, 103 line, 40 - 72 inch (52 in) focus grid
- Heavy-Duty cassette tray (not included with enclosure for Fixed DR)
- 120 VAC, 50/60 Hz, 500 VA power required
- UL Classified

Amrad AA4 FRS System with Amrad 400S HF Generator and Medlink Vivix 17x17 G DF

(Company provide manufacturer name, number and model number bidding.)

\$ 49,500.00

Initials of Bidder: 

21.0 AWARD:

This contract will be awarded to the lowest and best bidder meeting specifications.

22.0 REQUIRED FORMS:

All bidders are required to complete the attached and return with their submission:

- ✓ 22.1 Required Proof of Insurance
- ✓ 22.2 Vendor Form
- ✓ 22.3 W9 Form
- ✓ 22.4 Tax Form/Debt/Residence Certification
- 22.5 No Bid Questionnaire if applicable

**Contract Sheet
Bid 20-099**

**THE STATE OF TEXAS
COUNTY OF FORT BEND**

This memorandum of agreement made and entered into on the 25 day of August, 2020,
by and between Fort Bend County in the State of Texas (hereinafter designated County), acting herein by
County Judge KP George, by virtue of an order of Fort Bend County Commissioners Court, and
VXS Imaging, Inc. (hereinafter designated Contractor).
(company name)

WITNESSETH:

The Contractor and the County agree that the bid and specifications for the **X-ray Equipment for Employee Clinic** which are hereto attached and made a part hereof, together with this instrument and the bond (when required) shall constitute the full agreement and contract between parties and for furnishing the items set out and described; the County agrees to pay the prices stipulated in the accepted bid.

It is further agreed that this contract shall not become binding or effective until signed by the parties hereto and a purchase order authorizing the items desired has been issued.

Executed at Richmond, Texas this 25 day of August 2020.

KP George

Fort Bend County, Texas

By: _____
County Judge, KP George

By: Julie Tuckett
Signature of Contractor

By: Julie Tuckett, owner/president
Printed Name and Title

Request for Taxpayer Identification Number and Certification

**Give Form to the
requester. Do not
send to the IRS.**

Print or type
See Specific Instructions on page 2.

1 Name (as shown on your income tax return). Name is required on this line; do not leave this line blank. VXS Imaging, Inc.	
2 Business name/disregarded entity name, if different from above	
3 Check appropriate box for federal tax classification; check only one of the following seven boxes: <input type="checkbox"/> Individual/sole proprietor or single-member LLC <input type="checkbox"/> Limited liability company. Enter the tax classification (C=C corporation, S=S corporation, P=partnership) ▶ _____ <small>Note. For a single-member LLC that is disregarded, do not check LLC; check the appropriate box in the line above for the tax classification of the single-member owner.</small> <input type="checkbox"/> Other (see instructions) ▶ _____	<input type="checkbox"/> C Corporation <input checked="" type="checkbox"/> S Corporation <input type="checkbox"/> Partnership <input type="checkbox"/> Trust/estate
4 Exemptions (codes apply only to certain entities, not individuals; see instructions on page 3): Exempt payee code (if any) _____ Exemption from FATCA reporting code (if any) _____ <small>(Applies to accounts maintained outside the U.S.)</small>	
5 Address (number, street, and apt. or suite no.) 12503 Exchange Drive, Suite 514	Requester's name and address (optional) Fort Bend County
6 City, state, and ZIP code Stafford, TX 77477	
7 List account number(s) here (optional)	

Part I Taxpayer Identification Number (TIN)

Enter your TIN in the appropriate box. The TIN provided must match the name given on line 1 to avoid backup withholding. For individuals, this is generally your social security number (SSN). However, for a resident alien, sole proprietor, or disregarded entity, see the Part I instructions on page 3. For other entities, it is your employer identification number (EIN). If you do not have a number, see *How to get a TIN* on page 3.

Note. If the account is in more than one name, see the instructions for line 1 and the chart on page 4 for guidelines on whose number to enter.

Social security number											
OR											
Employer identification number											
7	6		-	0	4	8	8	0	6	2	

Part II Certification

Under penalties of perjury, I certify that:

1. The number shown on this form is my correct taxpayer identification number (or I am waiting for a number to be issued to me); and
2. I am not subject to backup withholding because: (a) I am exempt from backup withholding, or (b) I have not been notified by the Internal Revenue Service (IRS) that I am subject to backup withholding as a result of a failure to report all interest or dividends, or (c) the IRS has notified me that I am no longer subject to backup withholding; and
3. I am a U.S. citizen or other U.S. person (defined below); and
4. The FATCA code(s) entered on this form (if any) indicating that I am exempt from FATCA reporting is correct.

Certification instructions. You must cross out item 2 above if you have been notified by the IRS that you are currently subject to backup withholding because you have failed to report all interest and dividends on your tax return. For real estate transactions, item 2 does not apply. For mortgage interest paid, acquisition or abandonment of secured property, cancellation of debt, contributions to an individual retirement arrangement (IRA), and generally, payments other than interest and dividends, you are not required to sign the certification, but you must provide your correct TIN. See the instructions on page 3.

Sign Here	Signature of U.S. person ▶		Date ▶ 7/22/2020
------------------	----------------------------	--	------------------

General Instructions

Section references are to the Internal Revenue Code unless otherwise noted.

Future developments. Information about developments affecting Form W-9 (such as legislation enacted after we release it) is at www.irs.gov/fw9.

Purpose of Form

An individual or entity (Form W-9 requester) who is required to file an information return with the IRS must obtain your correct taxpayer identification number (TIN) which may be your social security number (SSN), individual taxpayer identification number (ITIN), adoption taxpayer identification number (ATIN), or employer identification number (EIN), to report on an information return the amount paid to you, or other amount reportable on an information return. Examples of information returns include, but are not limited to, the following:

- Form 1099-INT (interest earned or paid)
- Form 1099-DIV (dividends, including those from stocks or mutual funds)
- Form 1099-MISC (various types of income, prizes, awards, or gross proceeds)
- Form 1099-B (stock or mutual fund sales and certain other transactions by brokers)
- Form 1099-S (proceeds from real estate transactions)
- Form 1099-K (merchant card and third party network transactions)

- Form 1098 (home mortgage interest), 1098-E (student loan interest), 1098-T (tuition)
- Form 1099-C (canceled debt)
- Form 1099-A (acquisition or abandonment of secured property)

Use Form W-9 only if you are a U.S. person (including a resident alien), to provide your correct TIN.

If you do not return Form W-9 to the requester with a TIN, you might be subject to backup withholding. See What is backup withholding? on page 2.

By signing the filled-out form, you:

1. Certify that the TIN you are giving is correct (or you are waiting for a number to be issued),
2. Certify that you are not subject to backup withholding, or
3. Claim exemption from backup withholding if you are a U.S. exempt payee. If applicable, you are also certifying that as a U.S. person, your allocable share of any partnership income from a U.S. trade or business is not subject to the withholding tax on foreign partners' share of effectively connected income, and
4. Certify that FATCA code(s) entered on this form (if any) indicating that you are exempt from the FATCA reporting, is correct. See *What is FATCA reporting?* on page 2 for further information.

Job No.: RFO B20-099

TAX FORM/DEBT/RESIDENCE CERTIFICATION
(for Advertised Projects)

Taxpayer Identification Number (T.I.N.): 76-0488062

Company Name submitting Bid/Proposal: VXS Imaging, Inc.
12503 Exchange Drive, Suite 514, Stafford, TX 77477

Mailing Address: _____

Are you registered to do business in the State of Texas? Yes No

If you are an individual, list the names and addresses of any partnership of which you are a general partner or any assumed name(s) under which you operate your business

I. **Property:** List all taxable property in Fort Bend County owned by you or above partnerships as well as any d/b/a names. Include real and personal property as well as mineral interest accounts. (Use a second sheet of paper if necessary.)

<u>Fort Bend County Tax Acct. No.*</u>	<u>Property address or location**</u>
<u>P322236</u>	<u>12503 Exchange Drive, Suite 514, Stafford, TX 77477 (rented space where sales office and inventory is located)</u>
_____	_____
_____	_____
_____	_____

* This is the property account identification number assigned by the Fort Bend County Appraisal District.
 ** For real property, specify the property address or legal description. For business personal property, specify the address where the property is located. For example, office equipment will normally be at your office, but inventory may be stored at a warehouse or other location.

II. **Fort Bend County Debt** - Do you owe any debts to Fort Bend County (taxes on properties listed in I above, tickets, fines, tolls, court judgments, etc.)?
 Yes No If yes, attach a separate page explaining the debt.

III. **Residence Certification** - Pursuant to Texas Government Code §2252.001 *et seq.*, as amended, Fort Bend County requests Residence Certification. §2252.001 *et seq.* of the Government Code provides some restrictions on the awarding of governmental contracts; pertinent provisions of §2252.001 are stated below:

- (3) "Nonresident bidder" refers to a person who is not a resident.
- (4) "Resident bidder" refers to a person whose principal place of business is in this state, including a contractor whose ultimate parent company or majority owner has its principal place of business in this state.

I certify that VXS Imaging, Inc. is a Resident Bidder of Texas as defined in Government Code §2252.001.
 [Company Name]

I certify that _____ is a Nonresident Bidder as defined in Government Code §2252.001 and our principal place of business is _____.
 [Company Name] [City and State]



VXS Imaging Inc., 12503 Exchange Dr. Suite 514, Stafford, TX 77477
 (281) 242-X-ray (9729) Fax (281) 242-9750 e-mail: julie@vxsimaging.com

Quotation Prepared For:
 Fort Bend County
 Purchasing Department
 301 Jackson Street, Suite 201
 Richmond, TX 77469
 Attn: BID 20-099

QUOTATION NO 072220
 REPRESENTATIVE: Julie Tuckett
 INQUIRES REGARDING THIS QUOTATION SHOULD REFER TO QUOTATION NO.

VXS IMAGING INC. IS PLEASED TO SUBMIT THE FOLLOWING 1 PAGE QUOTATION OFFERING TO SELL THE PRODUCTS AND SERVICES DESCRIBED HEREIN AT THE STATED PRICES AND TERMS, SUBJECT TO YOUR ACCEPTANCE OF THE TERMS AND CONDITIONS ON THE FACE AND BACK HEREOF.

Ln #	Qty	DESCRIPTION OF ARTICLES AND/OR SERVICES	PRICE
1	1	<p>AmRad™ Advantage AA4 FRS System with Medlink Alto DR System</p> <p>AmRad 400S High Frequency Generator</p> <ul style="list-style-type: none"> • 25 kHz, 40 kW High Frequency (HF) generator • mA stations: 10s to 500L • mAs range: 0.1-630 mAs • Operates from 1 phase, 230V electric service or 3-phase 230V or 400-480V • Pedestal Mount <p>SST 3001 Floor Mount Tubestand</p> <ul style="list-style-type: none"> • Floor Mount, non-rotating Tubestand (82.25 in. tall) • 95.5 in. x 17 in. (includes travel track) floor rail assembly • 106 in. (8 ft. 10 in.) total length • Fixed length tube arm with manual x-ray tube rotation for centering to Wallstand • Angulation dial, operator handgrips, and electric positioning locks • 6 in. Trunnion Tube Mount with cooling fan for x-ray tube <p>Receptor Stand</p> <ul style="list-style-type: none"> • Heavy-duty Wallstand with motorized vertical travel, rotating center-mount enclosure for CR or DR applications (must specify at time of order) • Manual rotating enclosure with angulation gauge in 5 degree increments • Footswitch and column button actuation for motorized vertical travel • Grid Cabinet, 18 in. x 18 only • 10:1, 103 line, 40 - 72 in. (52 in) focus grid • Heavy-Duty cassette tray (Not included with enclosure for Fixed DR) • 120 VAC, 50/60 Hz, 500 VA power required • UL Classified 	

APPROX. SHIPPING DATE _____
 U.S. Shipping Point

F.O.B. Point _____

TERMS OF PAYMENT: LEASE FINANCING – OR:

- 50 % down payment with order.
- 50 % upon delivery of major equipment.

VXS IMAGING INC.
 SIGNATURE
 BY _____

Julie Tuckett

TITLE President _____ DATE 7/29/2020 _____

CUSTOMER'S SIGNATURE

ACCEPTED BY _____

TITLE _____ DATE _____

THIS QUOTATION IS GOOD FOR THIRTY (30) DAYS

Quotation Prepared For:
 Fort Bend County
 Purchasing Department
 301 Jackson Street, Suite 201
 Richmond, TX 77469
 Attn: BID 20-099

Ln #	Qty	DESCRIPTION OF ARTICLES AND/OR SERVICES	PRICE
2	1	<p>ST 1000 Mobile Radiographic Table</p> <ul style="list-style-type: none"> • 30 in. x 80 in. flat, seamless table top • 27.5 in. table height • Hospital-grade swivel casters with four locks • 500 lb. rated patient load • Electrical power not required <p>Standard X-Ray Tubes</p> <ul style="list-style-type: none"> • 0.6-1.5 mm focal spots, 200,000 heat units (40 kW generator) – E411 <p>Cables J995</p> <ul style="list-style-type: none"> • 35 ft. High Voltage cables, 150 kVp <p>Collimator 07385</p> <ul style="list-style-type: none"> • Certified 150 kVp manual collimator with swivel mount, LED light field, tray positioning laser, tape measure <p>VIVIX-S DR 17x17 Fixed Gadox Panel Panel</p> <ul style="list-style-type: none"> • 17x17 Fixed Flat Panel Detector • System Control Unit (SCU) • Image Processing Viewer Software • Cables and Acquisition Workstation • <p>VIVIX-S DR Acquisition Workstation Configuration</p> <ul style="list-style-type: none"> • Acquisition Workstation Hardware , Dell Optiplex 7060 • 8th Gen Intel Core i7 vPro Processor (6 Cores/12 MB/3.2 GHz) • Preload OS: Windows 10 Pro 64 • 16 GB DDR4, 2666 MHz UDIMM • 1 TB Local Mini-PACs in a RAID 1 (2 drives total) • VXVue with PureImpact DR Acquisition ViewerSoftware • Professional Monitor: 24 in. Touchscreen <p>(Specifications are subject to change without notification)</p> <p>Concurrent Viewers: Ten (10) Local Area Network (LAN) Viewers: DICOM Send – Multi Destination, DICOM Print, DICOM MWL Modality Worklist (Optional), User Friendly Touch Screen GUI, Measurement Tools, including: Auto and Manual Selection, Archive, Image Preview, Magnify, Zoom, Pan, Annotation, Window Level, Rotate, Repeat/Reject, L/R Marker.</p>	

Quotation Prepared For:
 Fort Bend County
 Purchasing Department
 301 Jackson Street, Suite 201
 Richmond, TX 77469
 Attn: BID 20-099

Ln #	Qty	DESCRIPTION OF ARTICLES AND/OR SERVICES	PRICE
3	1	Warranty: AmRad Structure – 5 years X-Ray Tube – 5 years prorated Generator – 5 years, parts ViVIX DR Includes; 5 Year Warranty ViVIX workstation and monitor hardware – 5 years Labor – 2 years onsite labor & remote support from VXS Imaging local service	
4	1	Removal of existing equipment Includes VXS Imaging de-install and removal of the current equipment	
5	1	Equipment Performance Evaluation	
6	1	Freight	
		Sub total	\$49,500.00
		OPTIONAL SERVICE CONTRACT FOR YEAR 3, 4, 5..... \$2,500.00/YEAR Service contract to cover onsite and remote troubleshooting, plus Annual PM or EPE.	

AMRAD  MEDICAL

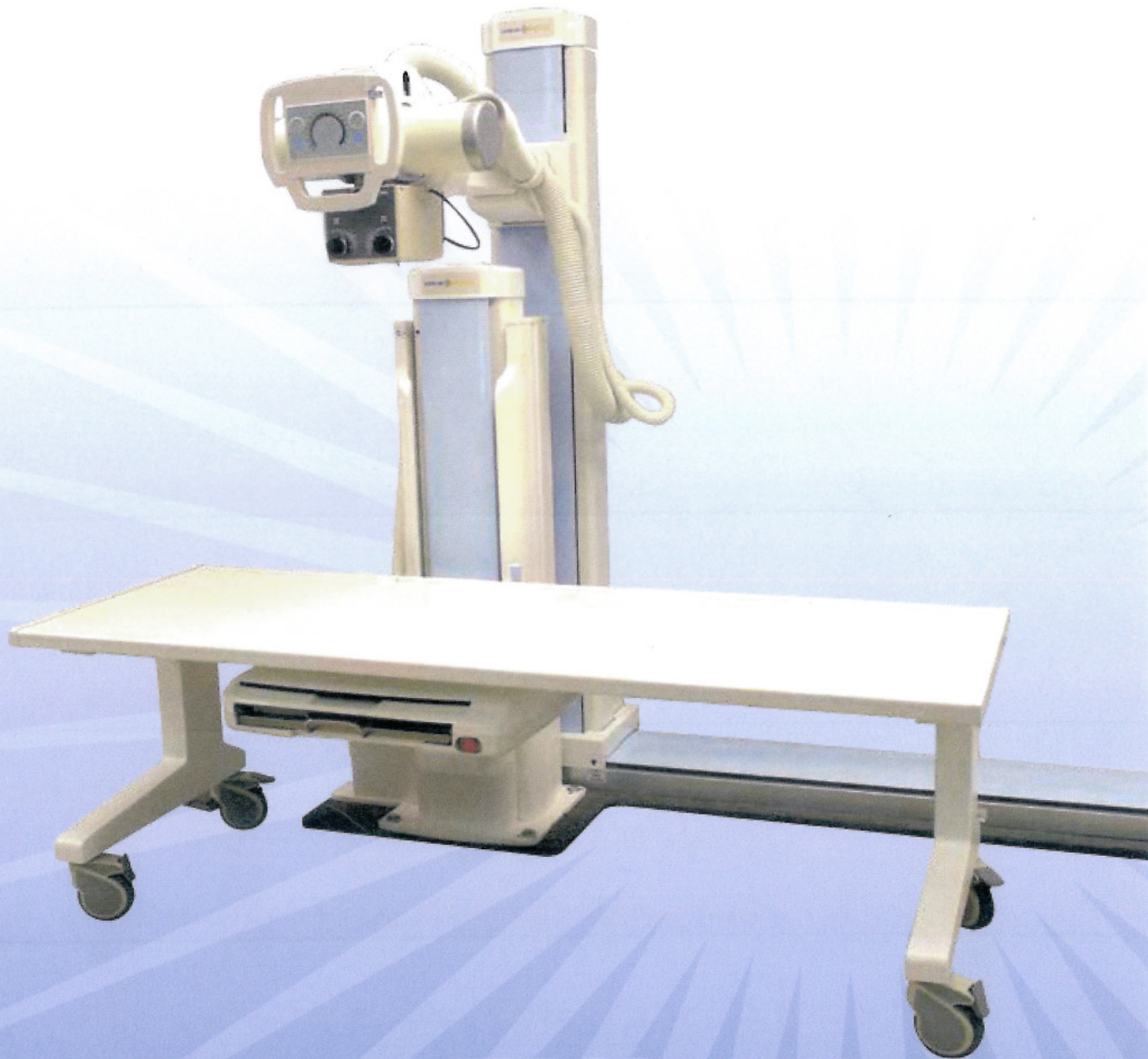

FRS | Floor Rail System

Multi-purpose Radiographic System

www.AmRadMedical.com



Decubitus Abdomen

- Easy to move floor mounted tube stand and motorized detector stand movement helps improve productivity and optimize workflow
- Traditional floor mounted tube stand means no complicated learning curve for technologists
- Floor mounted design minimizes installation requirements
- Mobile table with 500 pound patient capacity provides a full-featured system with maximum imaging capability and flexibility
- Compatible with CR or DR and customizable with any power generator, the FRS can be configured for the needs of any facility

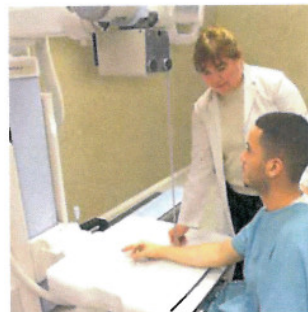

The Journal of Urgent Care Medicine states that Sinusitis is the number one diagnosis based on an analysis of Urgent Care CPT Codes.



The US FDA says that the Chest X-ray is the most common medical imaging examination.

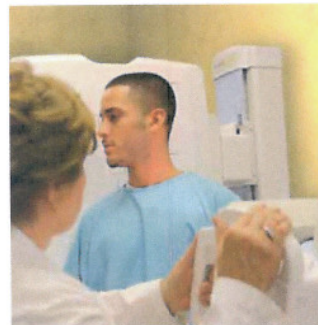

More than one million whiplash injuries occur each year due to automobile accidents.



Your shoulders are the most movable joints in your body and having them work properly is important.

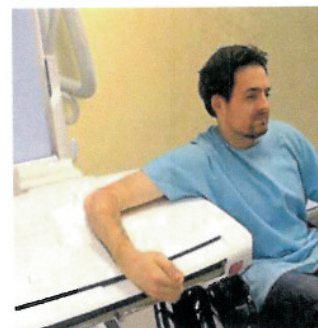

Disabled-World indicates that there are at least 1.7 million users of wheelchairs in the U.S.



Knee injuries are common at all ages.

ROTATION RANGE 105° TO -15° IN 5° INCREMENTS

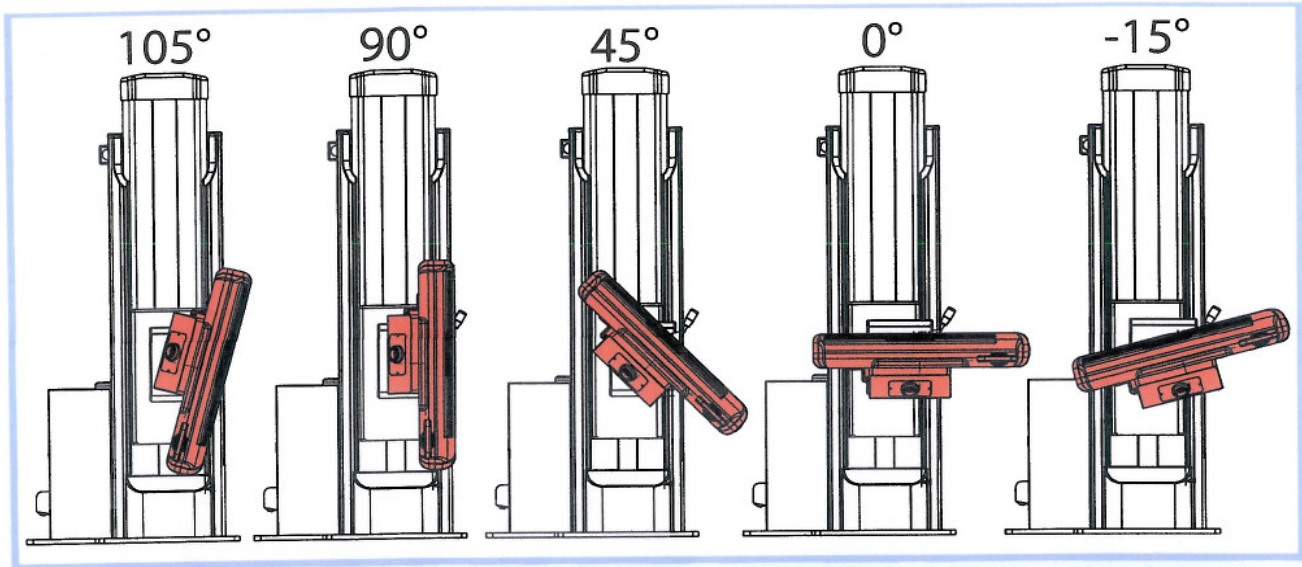

System Description



Motorized, elevating detector stand

- Footswitch and hand button operation
- -15° to +105° manual Bucky rotation in 5° increments
- Tray for CR or wireless DR cassettes
- Enclosure for fixed DR panels
- Removable 178 line, 8:1, mid-focus grid
- Collision sensing and power disrupt

Floor Mount Tubestand

- 8 foot floor rail
- Manual, fully counterbalanced movement
- Longitudinal, vertical and rotational electric locks
- Longitudinal travel: 72 inches
- Vertical travel: 59 inches
- Tube rotation: $\pm 135^\circ$

Mobile Table with 500 Pound Patient Capacity

Certified Manual Collimator

Configuration Flexibility

- 30kW to 80kW generators
- Up to 400,000 Heat Unit x-ray tube
- Compatible with most CR and DR technology

Options

- Automatic Exposure Control (AEC)
- Alternative grids



2901 W. Lawrence Avenue
Chicago, IL 60625 USA

Phone: 773-353-4000
Fax: 773-588-3424
Toll Free: 1-800-729-9729

AMRAD  MEDICAL

www.AmRadMedical.com





VIVIX-S 1717V

Wide and Slim Flat Panel Detector for Digital Radiography



Stable and Reliable
AED



Easy Installation
(cassette tray)



High Image Quality



Fast Booting Time



Efficient Workflow

Product

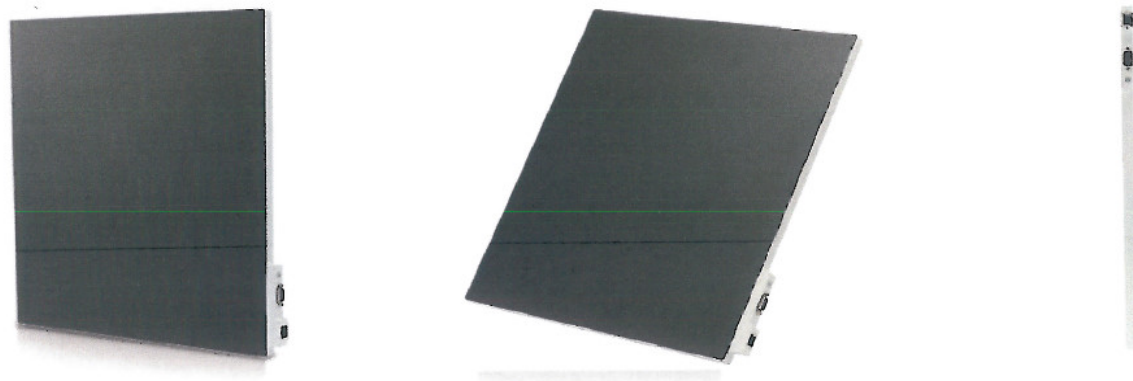

Features

- * 17"X17" fixed cassette size tethered panel
- * Stable and reliable AED (Automatic Exposure Detection)
- * Fast booting time: 15 seconds
- * 16 bit analog-to-digital conversion
- * Easy Installation with Plug and Play Technology

Drawing

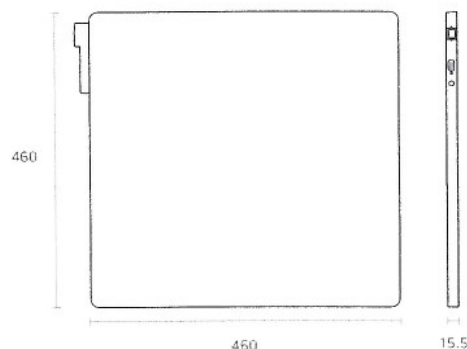

Technical Specifications

Model Name	FXRD-1717VA	FXRD-1717VB
Technology	a-Si TFT with PIN diode	
Scintillator	CsI:TI	Gd ₂ O ₂ S:Tb
Pixel Pitch	140µm	
Spatial Resolution	3.5lp/mm	
Pixels	3,072 x 3,072 pixels	
Image Size	430.08mm x 430.08mm	
Grayscale	16 bit	
Energy Range	40 – 150kV	
X-ray Generator Interface	Automatic Exposure Detection, External Line Trigger	
Data Interface	Gigabit Ethernet (1000BASE-T)	
Image Acquisition Time	2 sec	
Dimensions	460mm x 460mm x 15.5mm	
Weight	4.5kg	
Operating Environment	10°C – 35°C, 30 – 85% RH (non-condensing)	

FDA Approved

* Specifications are subject to change without prior notification.

S SERIES GENERATOR RADIOGRAPHIC SPECIFICATIONS

	320S	400S	500S	650S	800S
Model	320S	400S	500S	650S	800S
Part#	08105*	08106*	08107*	08108*	08109*
Power	32kW	40kW	50kW	65kW	80kW
kVp Range	40-125	40-125	40-150	40-150	40-150
mA Range	10-400	10-500	10-630	10-630	10-1000
mAs Range	0.1-630	0.1-630	0.1-630	0.1-800	0.1-1000

ELECTRICAL SPECIFICATIONS

		320S		400S		500S		650S	800S
Generator Model		54,000 VA		66,000 VA		80,000 VA		99,000 VA	123,000 VA
Max Momentary Input		54,000 VA		66,000 VA		80,000 VA		99,000 VA	123,000 VA
Line Phase		1PH	3PH	1PH	3PH	1PH	3PH	3PH	3PH
Min Distribution Xfrmr		75kVA	3x25kVA	75kVA	3x25kVA	100kVA	3x37.5kVA	3x37.5kVA	3x50kVA
Line Frequency		50/60	50/60	50/60	50/60	50/60	50/60	50/60	50/60
208 (202 to 214)	Power Supply #	07147-002	07147-004	07147-008	07147-010	07147-013	07147-014	-	-
	Line Match #	00530-000	07287	00530-000	07287	08326	07287	-	-
	Min Disconnect	130A	75A	159A	92A	192A	111A	-	-
	Min Cu wire run (AWG@FT)	2@50 1/0@100 3/0@150 4/0@200	6@50 2@100 1@150 1@200	2@50 2/0@100 4/0@150 4/0@200	4@50 2@100 1/0@150 2/0@200	1@50 3/0@100 250MCM @150 300MCM@ 200	4@50 1@100 2/0@150 3/0@200	-	-
220 (213 to 229)	Power Supply #	07147-002	07147-004	07147-008	07147-010	07147-013	07147-014	-	-
	Line Match #	00530-000	-	00530-000	-	08326	-	-	-
	Min Disconnect	123A	71A	150A	87A	182A	105A	-	-
	Min Cu wire run (AWG@FT)	4@50 1@100 2/0@150 3/0@200	6@50 4@100 2@150 1@200	2@50 1/0@100 3/0@150 4/0@200	6@50 2@100 1@150 1/0@200	1@50 3/0@100A 250MCM @150 300MCM@ 200	4@50 2@100 1/0@150 2/0@200	-	-
240 (230 to 250)	Power Supply #	07147-002	07147-004	07147-008	07147-010	07147-013	07147-014	-	-
	Line Match #	-	-	-	-	-	-	-	-
	Min Disconnect	113A	65A	138A	80A	167A	96A	-	-
	Min Cu wire run (AWG@FT)	4@50 1@100 2/0@150 3/0@200	6@50 4@100 2@150 1@200	2@50 1/0@100 3/0@150 4/0@200	6@50 2@100 1@150 1/0@200	2@50 2/0@100 4/0@150 250MCM @200	4@50 2@100 1/0@150 2/0@200	-	-
400 (361 to 428)	Power Supply #	-	-	-	07147-011	-	07147-015	07147-017	07147-019
	Line Match #	-	-	-	-	-	-	-	-
	Min Disconnect	-	-	-	48A	-	58A	72A	89A
	Min Cu wire run (AWG@FT)	-	-	-	10@50 8@100 6@150 4@200	-	10@50 6@100 4@150 4@200	8@50 6@100 4@150 2@200	8@50 4@100 2@150 2@200
480 (461 to 504)	Power Supply #	-	-	-	07147-012	-	07147-016	07147-018	07147-020
	Line Match #	-	-	-	-	-	-	-	-
	Min Disconnect	-	-	-	40A	-	48A	60A	74A
	Min Cu wire run (AWG@FT)	-	-	-	12@50 8@100 8@150 6@200	-	10@50 8@100 6@150 4@200	10@50 6@100 4@150 4@200	8@50 6@100 4@150 2@200

*** Notes:**

1. 230VAC labeled generator operates from 208VAC to 240VAC lines. A line match transformer is only needed if specified in the chart above.
2. The power supply# and the line match# are the required options to operate the generator at the specified nominal Line VAC
3. Maximum VAC drop under load at the generator input is 5%

4. Run "RUN" is defined as length of wire between the building's main incoming electrical panel and the service disconnect switch in the X-ray room.
5. The generator does not provide 110/120 VAC supply.
6. Auxiliary power supplies: 24VAC@6A and 24VDC@10A
7. Min disconnect: Refers to the minimum Amp rating of the current protection whether it is via a circuit breaker or a fused disconnect switch. See NEC 660.5 for details.

Min Disconnect Amps = Max momentary Amps/2

1PH Max Momentary Amps = Max Momentary Input/Nominal Line VAC.

3PH Max Momentary Amps = Max Momentary Input/Nominal Line VAC/ $\sqrt{3}$

Common Fused Disconnect sizes:

50A, 60A, 100A, 200A

Common Circuit Breaker sizes:

1PH/240: 125A,150A; 3PH/240: 40A,45A,50A,60A,70A,80A,90A,100A; 3PH/480: 40,50,60,70,80,90,100

ENVIRONMENTAL OPERATING SPECIFICATIONS

Ambient temperature range	Relative humidity range	Atmosphere pressure range
50°F (10°C) to 104°F (40°C)	30% to 75%	20.67 inHg (700 hPa) to 31.30 inHg (1060 hPa)

TUBE COMPATIBILITY LIST

TOSHIBA	VARIAN
7239, 7242, 7252-AL, 7252-RA, 7254, 7255, 7869, 7884	RAD14, RAD56

DIMENSIONS

COMPONENT	Length	Width	Height	Weight
CRATED Generator (Shipping Information)	1070 mm (42.1")	620 mm (24.4")	740 mm (29.1")	92 kg (203 lb)
Generator with Leveling Legs	445 mm (17.5")	360 mm (14.2")	564.5 mm (22.2")	65 kg (143 lb)
Pedestal	298 mm (11.7")	236 mm (9.3")	930 mm (36.6")	10 kg (22 lb)
RAD Console Graphic Display	430 mm (16.9")	290 mm (11.4")	50 mm (1.9")	6 kg (13.2 lb)

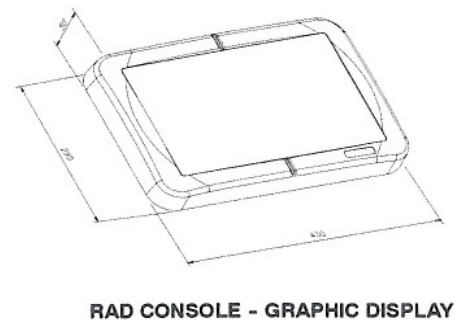
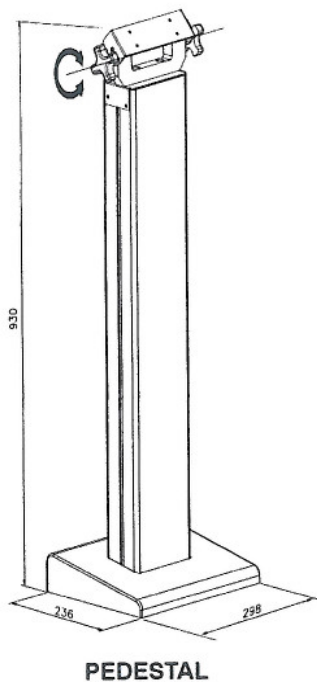
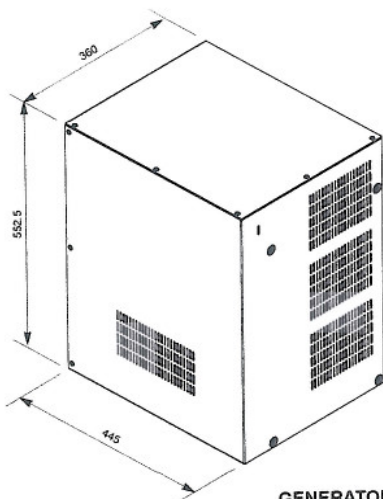

CERTIFICATE OF INTERESTED PARTIES

FORM 1295

1 of 1

Complete Nos. 1 - 4 and 6 if there are interested parties.
 Complete Nos. 1, 2, 3, 5, and 6 if there are no interested parties.

**OFFICE USE ONLY
 CERTIFICATION OF FILING**

Certificate Number:
 2020-654574

Date Filed:
 08/07/2020

Date Acknowledged:
 08/25/2020

1 Name of business entity filing form, and the city, state and country of the business entity's place of business.
 VXS Imaging
 Stafford, TX United States

2 Name of governmental entity or state agency that is a party to the contract for which the form is being filed.
 Fort Bend County

3 Provide the identification number used by the governmental entity or state agency to track or identify the contract, and provide a description of the services, goods, or other property to be provided under the contract.
 B20-099
 X-Ray Machine

4	Name of Interested Party	City, State, Country (place of business)	Nature of interest (check applicable)	
			Controlling	Intermediary
	VXS Imaging, Inc.	Stafford, TX United States	X	

5 Check only if there is NO Interested Party.

6 UNSWORN DECLARATION

My name is _____, and my date of birth is _____.

My address is _____, _____, _____, _____, _____.
(street) (city) (state) (zip code) (country)

I declare under penalty of perjury that the foregoing is true and correct.

Executed in _____ County, State of _____, on the _____ day of _____, 20____.
(month) (year)

 Signature of authorized agent of contracting business entity
 (Declarant)