



**REVIEW BY FORT BEND COUNTY  
COMMISSIONERS COURT**

**Fort Bend County  
Engineering Department**  
301 Jackson Suite 401  
Richmond, Texas 77469  
281 633 7500  
Permits@fortbendcountytexas.gov

Right of Way Permit  
 Commercial Driveway Permit  
Permit No: 2017-17508

**Applicant:** Monarch Civil Constructors, LLC

**Job Location Site:** Intersection of Hampton Breeze Ln and Dry Stone Ln, Richmond, TX 77469

**Bond No.**                      **Date of Bond:** 12/14/2017 **Amount:** \$10,000.00

The above applicant came to make use of certain Fort Bend County property subject to, "The Order Regulating the Laying, Construction, Maintenance, and Repair of Buried Cables, Conduits, and Pole Lines, In, Under, Across or Along Roads, Streets, Highways, and Drainage Ditches in Fort Bend County, Texas, Under the Jurisdiction of the Commissioners Court of Fort Bend County, Texas," as passed by the Commissioners Court of Fort Bend County, Texas, of the Minutes of the Commissioners Court of Fort Bend County, Texas, to the extent that such order is not inconsistent with Chapter 181, Vernon's Texas Statutes and Codes Annotated.

**Notes:**

1. Evidence of review by the Commissioners Court must be kept on the job site and failure to do so constitutes grounds for job shutdown.
2. Written notices are required:
  - a. 48 hours in advance of construction start up, and
  - b. When construction is completed and ready for final inspection, submit notification to Permit Administrator thru MyGovernmentOnline.org portal.
3. This permit expires one (1) year from date of permit if construction has not commenced.

On this 2nd day of January, 2018, Upon Motion of Commissioner Meyers, seconded by Commissioner Patterson, duly put and carried, it is ORDERED, ADJUDGED AND DECREED that said notice of said above purpose is hereby acknowledged by the Commissioners Court of Fort Bend County, Texas, and that said notice be placed on record according to the regulation order thereof.

**Signature**

By: Charles O. Dean  
County Engineer

By: Mark Vogt  
Drainage District Engineer/Manager

Presented to Commissioners Court and approved.

Date Recorded 1-4-2018 Comm. Court No. 12A

Clerk of Commissioners Court

By: Janet Willis  
Deputy



**PERMIT APPLICATION REVIEW FORM FOR  
CABLE, CONDUIT, AND POLE LINE ACTIVITY  
IN FORT BEND COUNTY**

**Fort Bend County  
Engineering Department**  
301 Jackson Suite 401  
Richmond, Texas 77469  
281.633.7500  
Permits@fortbendcountytx.gov

- Right of Way Permit  
 Commercial Driveway Permit  
Permit No: 2017-17508

The following "Notice of Proposed Cable, Conduit, and/or Pole Line activity in Fort Bend County" and accompanying attachments have been reviewed and the notice conforms to appropriate regulations set by Commissioner's Court of Fort Bend County, Texas.

**(1) COMPLETE APPLICATION FORM:**

- a. Name of road, street, and/or drainage ditch affected.  
 b. Vicinity map showing course of directions  
 c. Plans and specifications

**(2) BOND:**

- County Attorney, approval when applicable.  
 Perpetual bond currently posted. Bond No: \_\_\_\_\_ Amount: \_\_\_\_\_  
 Performance bond submitted. Bond No: [REDACTED] Amount: \$10,000.00  
 Cashier's Check Check No. \_\_\_\_\_ Amount: \_\_\_\_\_

**(3) DRAINAGE DISTRICT APPROVAL (WHEN APPLICABLE):**

Mark Vogler  
Drainage District Approval

12/27/17  
Date

We have reviewed this project and agree it meets minimum requirements.

Charles O. Ay  
Permit Administrator

12/20/2017  
Date



**PERFORMANCE BOND COVERING ALL CABLE CONDUIT AND/OR POLE LINE  
ACTIVITY IN UNDER ACROSS OR ALONG FORT BEND COUNTY ROAD  
COMMERCIAL DRIVEWAY AND MEDIAN OPENINGS OR MODIFICATIONS  
(AUTHORIZED)**

BOND NO. 2018001400

THE STATE OF TEXAS  
COUNTY OF FORT BEND

KNOW ALL MEN BY THESE PRESENTS:

THAT WE, Monarch Civil Constructors, LLC whose (address, phone) is 20228 Schiel Road Cypress, TX 77433, (713) 808 - 9388 Texas, hereinafter called the Principal, and North American Specialty Insurance Company a Corporation existing under and by virtue of the laws of the state of NH and authorized to do an indemnifying business in the state of Texas, and whose principal office is located at (name/address/phone) North American Specialty Insurance Company 3050 Post Oak Boulevard, Suite 850, Houston, TX 77056 whose officer residing in the State of Texas, authorized to accept service in all suits and actions brought whining said state is Erica Anne Cox c/o Technical Assurance, L.L.C. and whose address is 26623 Oak Ridge Drive, The Woodlands, TX 77380 hereinafter called the Surety, and held and firmly bound unto, Robert E. Hebert, County Judge of Fort Bend County, Texas, or his successors in office, in the full sum of Ten Thousand Dollars and 00/100 Dollars (\$10,000.00) current, lawful money of the United States of America, to be paid to said Robert E. Hebert, County Judge of Fort Bend County, Texas, or his successors in office, to which payment well and truly to be made and done, we, the undersigned, bind ourselves and each of us, our heirs, executors, administrators, successors, assigns, and legal representatives, jointly and severally, by these presents.

THE CONDITION OF THIS BOND IS SUCH THAT, WHEREAS, the above bounden principal contemplates laying, constructing maintaining and/or repairing one or more cables, conduits, and/or pole lines in, under, across and/or along roads, streets and highways, commercial driveway and median openings or modifications in the County of Fort Bend, and the State of Texas, under the jurisdiction of the Commissioners' Court of Fort Bend County, Texas, pursuant to the Commissioners' Court order adopted on the 1st day of December, A.D. 1980, recorded in Volume 13, of the Commissioners' Court Minutes of Fort Bend County, Texas, regulating same, which Commissioners' Court order is hereby referred to and made a part hereof for all purposes as though fully set out herein;

AND WHEREAS, the principal desires to provide Fort Bend County with a performance bond covering all such cable, conduit and/or pole line activity, commercial driveway and median Openings or modifications;

NOW, THEREFORE, if the above bounden principal shall faithfully perform all its cable, conduit and/or pole line activity (including, but not limited to the laying, construction, maintenance and/or repair of cables, conduits and/or pole lines) in, under, across and/or along roads, streets and highways, commercial driveway and median openings or modifications in the County of Fort Bend and State of Texas, under the jurisdiction of the Commissioners Court of Fort Bend County, Texas, pursuant to and in accordance with minimum requirements and conditions of the above mentioned Commissioners' Court order set forth and specified to be by said principal done and performed, at the time and in the manner therein specified, and shaft pay over and make good and reimburse Fort Bend County, all loss and damages which Fort Bend County may sustain by reason of any failure or default on the part of said principal, then this obligation shall be null and void, otherwise to remain in full force and effect.

This bond is payable at the County Courthouse in the County of Fort Bend and State of Texas.

It is understood that at any time Fort Bend County deems itself insecure under this bond, it may require further and/or additional bonds of the principal.

EXECUTED this 14th day of December, 2017

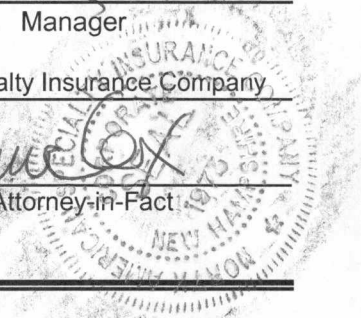
Monarch Civil Constructors, LLC  
PRINCIPAL

BY Ronnie Vaughan Manager

North American Specialty Insurance Company  
SURETY

BY Erica Anne Cox, Attorney-in-Fact

CCM 1-2-2018 # 12A  
Fort Bend County Clerk  
Return Admin Serv Coord  
RAC



NAS SURETY GROUP

NORTH AMERICAN SPECIALTY INSURANCE COMPANY
WASHINGTON INTERNATIONAL INSURANCE COMPANY

GENERAL POWER OF ATTORNEY

KNOW ALL MEN BY THESE PRESENTS, THAT North American Specialty Insurance Company, a corporation duly organized and existing under laws of the State of New Hampshire, and having its principal office in the City of Manchester, New Hampshire, and Washington International Insurance Company, a corporation organized and existing under the laws of the State of New Hampshire and having its principal office in the City of Schaumburg, Illinois, each does hereby make, constitute and appoint:

EDWARD ARENS, PHILIP BAKER, MICHELE BONNIN,

ERICA ANNE COX, JILLIAN MCKENZIE and REBECCA GARZA

JOINTLY OR SEVERALLY

Its true and lawful Attorney(s)-in-Fact, to make, execute, seal and deliver, for and on its behalf and as its act and deed, bonds or other writings obligatory in the nature of a bond on behalf of each of said Companies, as surety, on contracts of suretyship as are or may be required or permitted by law, regulation, contract or otherwise, provided that no bond or undertaking or contract or suretyship executed under this authority shall exceed the amount of: FIFTY MILLION (\$50,000,000.00) DOLLARS

This Power of Attorney is granted and is signed by facsimile under and by the authority of the following Resolutions adopted by the Boards of Directors of both North American Specialty Insurance Company and Washington International Insurance Company at meetings duly called and held on the 9th of May, 2012:

"RESOLVED, that any two of the Presidents, any Managing Director, any Senior Vice President, any Vice President, any Assistant Vice President, the Secretary or any Assistant Secretary be, and each or any of them hereby is authorized to execute a Power of Attorney qualifying the attorney named in the given Power of Attorney to execute on behalf of the Company bonds, undertakings and all contracts of surety, and that each or any of them hereby is authorized to attest to the execution of any such Power of Attorney and to attach therein the seal of the Company; and it is

FURTHER RESOLVED, that the signature of such officers and the seal of the Company may be affixed to any such Power of Attorney or to any certificate relating thereto by facsimile, and any such Power of Attorney or certificate bearing such facsimile signatures or facsimile seal shall be binding upon the Company when so affixed and in the future with regard to any bond, undertaking or contract of surety to which it is attached."



By [Signature] Steven P. Anderson, Senior Vice President of Washington International Insurance Company & Senior Vice President of North American Specialty Insurance Company



By [Signature] Michael A. Ito, Senior Vice President of Washington International Insurance Company & Senior Vice President of North American Specialty Insurance Company

IN WITNESS WHEREOF, North American Specialty Insurance Company and Washington International Insurance Company have caused their official seals to be hereunto affixed, and these presents to be signed by their authorized officers this 1st day of July, 2016.

North American Specialty Insurance Company
Washington International Insurance Company

State of Illinois
County of Cook ss:

On this 1st day of July, 2016, before me, a Notary Public personally appeared Steven P. Anderson, Senior Vice President of Washington International Insurance Company and Senior Vice President of North American Specialty Insurance Company and Michael A. Ito, Senior Vice President of Washington International Insurance Company and Senior Vice President of North American Specialty Insurance Company, personally known to me, who being by me duly sworn, acknowledged that they signed the above Power of Attorney as officers of and acknowledged said instrument to be the voluntary act and deed of their respective companies.



[Signature] M. Kenny, Notary Public

I, Jeffrey Goldberg, the duly elected Assistant Secretary of North American Specialty Insurance Company and Washington International Insurance Company, do hereby certify that the above and foregoing is a true and correct copy of a Power of Attorney given by said North American Specialty Insurance Company and Washington International Insurance Company, which is still in full force and effect.

IN WITNESS WHEREOF, I have set my hand and affixed the seals of the Companies this 14th day of December, 2017

[Signature] Jeffrey Goldberg, Vice President & Assistant Secretary of Washington International Insurance Company & North American Specialty Insurance Company

**North American Specialty Insurance Company  
Washington International Insurance Company**

**TEXAS CLAIMS INFORMATION**

**IMPORTANT NOTICE**

In order to obtain information or make a complaint:

You may contact **Jim Carpenter, Vice President – Claims at 1-800-338-0753**

You may call **Washington International Insurance Company and/or North American Specialty Insurance Company's toll-free number for information or to make a complaint at:**

**1-800-338-0753**

You may also write to **Washington International Insurance Company and/or North American Specialty Insurance Company at the following address:**

**475 N. Martingale Road  
Suite 850  
Schaumburg, IL 60173**

You may contact the **Texas Department of Insurance** to obtain information on companies, coverages, rights or complaints at:

**1-800-252-3439**

You may write the **Texas Department of Insurance:**

**P.O. Box 149104  
Austin, TX 78714-9104  
Fax: (512) 475-1771  
Web: <http://www.tdi.state.tx.us>  
Email: [ConsumerProtection@tdi.state.tx.us](mailto:ConsumerProtection@tdi.state.tx.us)**

**PREMIUM OR CLAIM DISPUTES:**

Should you have a dispute concerning your premium or about a claim you should first contact the **Washington International Insurance Company and/or North American Specialty Insurance Company**. If the dispute is not resolved, you may contact the **Texas Department of Insurance**.

**ATTACH THIS NOTICE TO YOUR POLICY:**

This notice is for information only and does not become a part or condition of the attached document.

**ADVISO IMPORTANTE**

Para obtener informacion o para someter un queja:

Puede comunicarse con **Jim Carpenter, Vice President – Claims, al 1-800-338-0753**

Usted puede llamar al numero de telefono gratis de **Washington International Insurance Company and/or North American Specialty Insurance Company's** para informacion o para someter una queja al:

**1-800-338-0753**

Usted tambien puede escribir a **Washington International Insurance Company and/or North American Specialty Insurance Company al:**

**475 N. Martingale Road  
Suite 850  
Schaumburg, IL 60173**

Puede escribir al **Departamento de Seguros de Texas** para obtener informacion acerca de companias, coberturas, derechos o quejas al:

**1-800-252-3439**

Puede escribir al **Departamento de Seguros de Texas:**

**P.O. Box 149104  
Austin, TX 78714-9104  
Fax: (512) 475-1771  
Web: <http://www.tdi.state.tx.us>  
Email: [ConsumerProtection@tdi.state.tx.us](mailto:ConsumerProtection@tdi.state.tx.us)**

**DISPUTAS SOBRE PRIMAS O RECLAMOS:**

Si tiene una disputa concerniente a su prima o a un reclamo, debe comunicarse con el **Washington International Insurance Company and/or North American Specialty Insurance Company** primero. Si no se resuelve la disputa, puede entonces comunicarse con el **Departamento de Seguros de Texas**.

**UNA ESTE AVISO A SU POLIZA**

Este aviso es solo para proposito de informacion y no se convierte en parte o condicion del documento adjunto.

FILED AND RECORDED  
OFFICIAL PUBLIC RECORDS

*Laura Richard*

Laura Richard, County Clerk

Fort Bend County Texas

January 03, 2018 03:35:56 PM



FEE: \$0.00

RR1

**2018001400**

**TECHNICAL ASSURANCE, LLC**

26623 Oak Ridge Drive  
The Woodlands, TX 77380

Phone:(281) 296-9997 E-mail: mrothe@technical-assurance.com

**Invoice**

Date	Invoice #
12/14/2017	7-B66-N8650

Principal
Monarch Civil Constructors 20228 Schiel Rd. Cypress, TX 77433

Bond No.
----------



Issuing Carrier
North American Specialty Ins. Co.

Bond Details	Amount Due
TX Fort Bend Co Pole Line Performance Bond - Walnut Creek Section 14 Bond Amount: \$10,000.00  Obligee Robert e. Hebert, County Judge of Fort Bend County  BOND TERM: DECEMBER 14, 2017 TO DECEMBER 13, 2018	100.00
<b>Payments/Credits</b>	\$0.00

Surety Premium and Related Client Services

**Balance Due** \$100.00

*Thank you for your business. We appreciate your prompt payment.*

# LENNAR HOMES OF TEXAS LAND AND CONSTRUCTION, LTD.

ON BEHALF OF

## FORT BEND COUNTY MUNICIPAL UTILITY DISTRICT NO. 152

PLANS

### FOR CONSTRUCTION OF

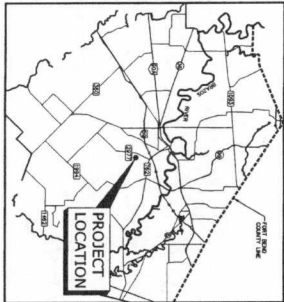
# WATER DISTRIBUTION, SANITARY SEWER, DRAINAGE FACILITIES AND PAVING

TO SERVE

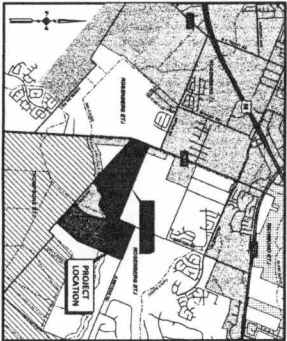
## WALNUT CREEK SECTION 14

FORT BEND COUNTY, TEXAS

DESIGN JOB NO. 1278-029-00 (W.S.&D.)      CONTRACT NO. 1  
 DESIGN JOB NO. 0371-155-00 (PAVING)      CONTRACT NO. 1



**VICINITY MAP**  
SCALE: N.T.S.



**LOCATION MAP**  
N.T.S.  
KEY MAP 6450 & 646A

Sheet Number	Sheet Title	Sheet List Table
1	COVER SHEET	
2	CONSTRUCTION NOTES	
3	WATER DISTRIBUTION AND SANITARY SEWER INDEX (NOT IN PAVING CONTRACT)	
4	PAVING AND STORM SEWER INDEX	
5	DRAINAGE AREA MAP AND POLLUTION PREVENTION PLAN	
6	SIGNAGE PLAN (NOT IN WS&D CONTRACT)	
7	DRAINAGE CALCULATIONS (NOT IN PAVING CONTRACT)	
8	PLAN AND PROFILE - WINDMILL RIDGE LANE AND OUTFALL	
9	PLAN AND PROFILE - COLEY MANOR LANE	
10	PLAN AND PROFILE - ORY STONE LANE	
11	PLAN AND PROFILE - HAMPTON BREEZE LANE	
12	PLAN AND PROFILE - IRBY COBB BLVD.	
13	PLAN AND PROFILE - OFFSITE STORM	
14	STORM SEWER DETAILS 1 (NOT IN PAVING CONTRACT)	
15	STORM SEWER DETAILS 2 (NOT IN PAVING CONTRACT)	
16	SANITARY SEWER DETAILS (NOT IN PAVING CONTRACT)	
17	WATER LINE DETAILS AND (CEQA NOTES) (NOT IN PAVING CONTRACT)	
18	WATER LINE DETAILS (NOT IN PAVING CONTRACT)	
19	PAVING DETAILS 1 (NOT IN WS&D CONTRACT)	
20	PAVING DETAILS 2 (NOT IN WS&D CONTRACT)	
21	POLLUTION PREVENTION DETAILS AND NOTES	
22	TPOOT DETAILS - PEDESTRIAN FACILITIES - CURB RAMPS (NOT IN WS&D CONTRACT)	
23	LOT GRADING PLAN	
24	CONSTRUCTION CONTROL MAP	

EXCEL, FORT BEND COUNTY ENGINEER

DESIGNED BY: *Richard W. Stricker, P.E.*

DATE: 10/21/17

THESE SIGNATURES ARE VOID IF CONSTRUCTION HAS NOT COMMENCED IN (1) YEAR FROM DATE OF APPROVAL.

APPROVED BY: *[Signature]*

DATE: 10/27/17

**IDS Engineering Group**

3240 West Riverway, Suite 700  
Houston, TX 77006  
Tel: 281-468-2222  
Fax: 281-468-2222  
www.idseng.com

DESIGNED BY: *Richard W. Stricker, P.E.*

DATE: 10/21/17

APPROVED BY: *[Signature]*

DATE: 10/27/17

SUPERVISED BY: IDS SURVEYORS

FB NO. 9102017

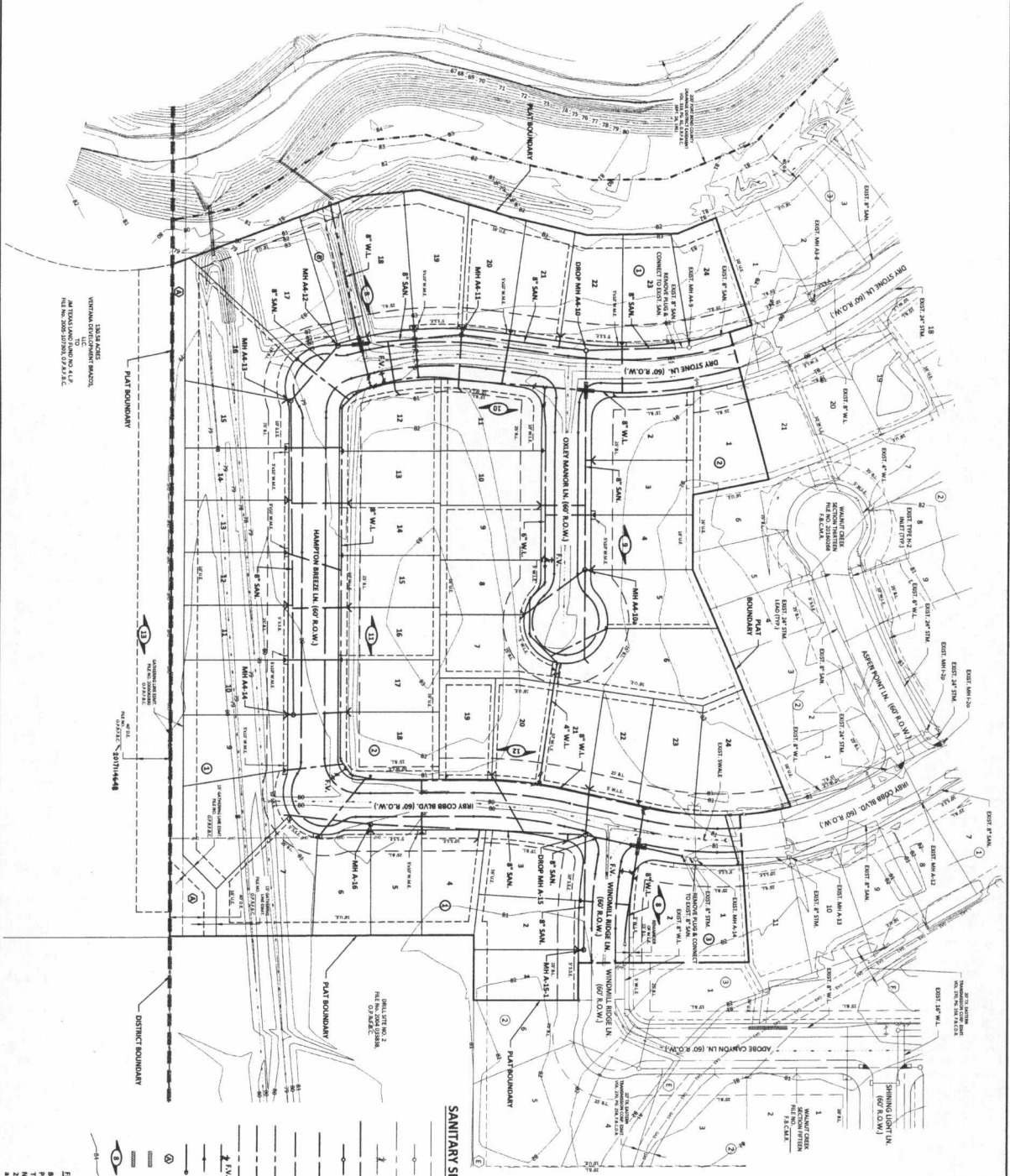
CITY OF ROSENBERG  
DEPARTMENT OF PUBLIC WORKS AND ENGINEERING

JOHN MARSH, CITY MANAGER

CHARLES W. EASTLAND, P.E., CITY ENGINEER

SHEET NO. 1 OF 24 SHEETS








**SANITARY SEWER AND WATER LINE LEGEND**

- EXIST. SANITARY SEWER
- EXIST. SANITARY MANHOLE
- EXIST. WATERLINE
- EXIST. FISHING VALVE w/DATE VALVE
- PROP. SANITARY SEWER
- PROP. SANITARY MANHOLE
- 6" SANITARY LEAD w/WAVE TO SERVE 2 LOTS (UNLESS OTHERWISE NOTED)
- 6" SANITARY LEAD TO SERVE 1 LOT
- EXIST. 1" WATER LEAD w/WAVE TO SERVE 2 LOTS
- EXIST. 1" WATER LEAD TO SERVE 1 LOT
- PROP. WATER LINE
- PROP. FISHING VALVE w/DATE VALVE
- PROP. MANHOLE
- PROP. 2" BLOW OFF VALVE w/PLUG
- INDICATES A RESTRICTED RESERVE
- CENTER ONE FULL JOINT OF PROP. WATER LINE
- CENTER ONE FULL JOINT OF PROP. SANITARY SEWER
- SHEET INDEX
- EXIST. GROUND CONTOUR

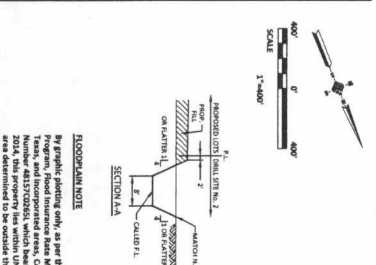
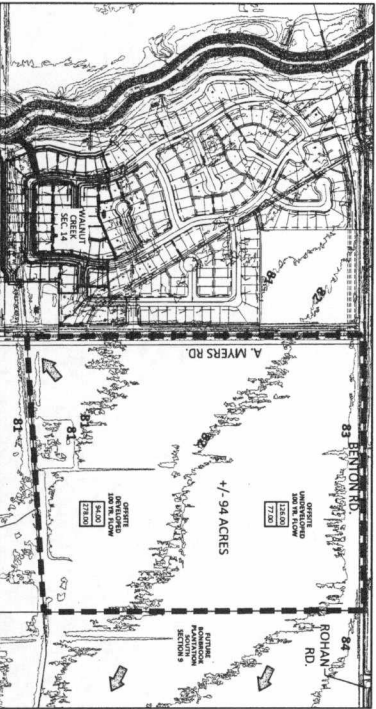
**FLOODPLAIN NOTE**

By graphic detailing only as per the National Flood Insurance Program, Flood Insurance Rate Map (FIRM), Fort Bend County, Texas, and District 3, Community No. 48222A, Map No. 130300010001, dated 08/11/2014, this property falls within UNDESIGNED ZONE X, which is an area determined to be outside the 500-year floodplain.

<p><b>CITY OF ROSENBERG</b>                    WALNUT CREEK SEC. 14                  WATER DISTRIBUTION AND                  SANITARY SEWER INDEX</p>		<p><b>IDS Engineering Group</b>                    BRIAN D. GIBBOLD                  PROJECT MANAGER                  7/17/2017</p>		<p><b>FORT BEND COUNTY ENGINEERING DEPARTMENT</b>                  APPROVED:                   DATE: 06/15/17</p>							
<p>PROJECT: WALNUT CREEK SEC. 14                  SHEET: 3 OF 24</p>	<p>DATE: 7/17/2017</p>	<p>SCALE: 1"=40'</p>	<p>REVISIONS:</p> <table border="1"> <tr><th>No.</th><th>DATE</th><th>REVISIONS</th></tr> <tr><td> </td><td> </td><td> </td></tr> </table>	No.	DATE	REVISIONS				<p>DATE: 7/17/2017</p>	<p>SCALE: 1"=40'</p>
No.	DATE	REVISIONS									



- PROPOSED PAVEMENT WITH CONCRETE CURB AND GUTTER AWAY, ALL PROPOSED FABRIC FINISH BEHIND THE CURB.**
- EXISTING PAVEMENT**
- PROPOSED STORM SEWER AND MANHOLE**
- PROPOSED 18" INCHES WITH FLOW CONTROL AND AWAY (ALL CURB METERS WITH 24" LAD UNLESS OTHERWISE NOTED)**
- INDICATES A STORM SEWER ESTIMATE**
- EXISTING GROUND CONTOUR**
- FUTURE DRAINAGE AT STORM SEWER (100% TR EVENT)**
- INDICATES A DRAINAGE BOUNDARY**
- FUTURE FENCE FINISH**
- INDICATES A DRAINAGE BOUNDARY (100% TR EVENT)**
- INDICATES A DRAINAGE BOUNDARY AT STORM SEWER (DESIGN EVENT)**
- GRAVEL BIAS**
- STABILIZED CONSTRUCTION ACCESS**
- STAKE / STAKE II INLET**
- STAKE / STAKE II INLET**
- PILE CELL TO BE LOCATED BY THAM COMPUTATION TO BE LOCATED BY CONCRETE THICK VASHPUT**
- MAXIMUM FOUNDING ELEVATION**
- INDICATES A RESTRICTED RESERVE DIRECTION**



**FLOODPLAIN NOTE**

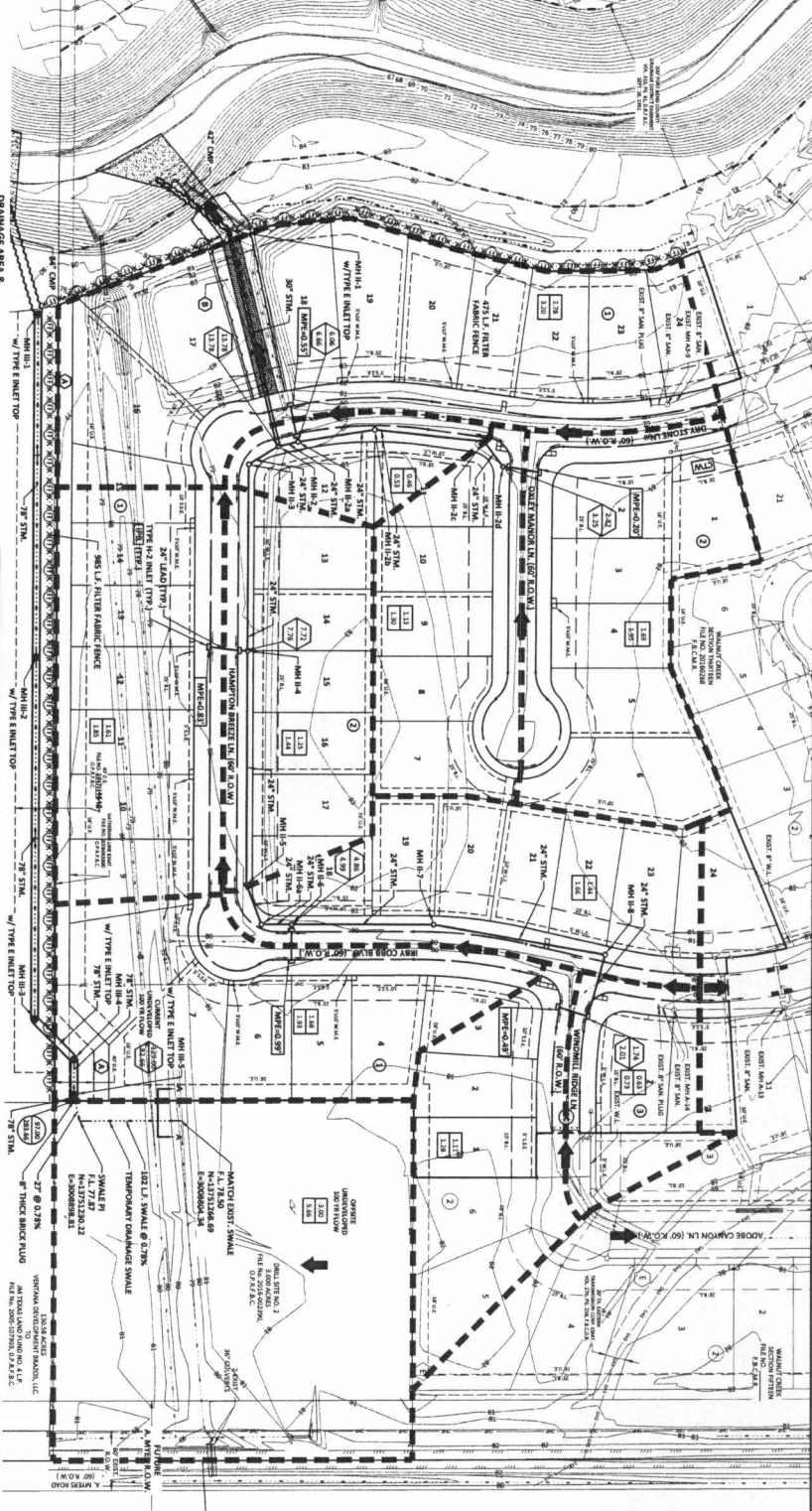
By graphic shading only, as per the National Flood Insurance Program, Flood Insurance Rate Map (FIRM), Fort Bend County, Number 48137C0205, which bears an effective date of April 2, 2014, this property lies within UNDEVELOPED ZONE X, which is an area determined to be suitable for some types of development.

**CITY OF ROSENBERG**

**WALNUT CREEK SEC. 14**

**DRAINAGE AREA MAP AND POLLUTION PREVENTION PLAN**

DATE: 5 of 24



**ENGINEERING**

**IDS Engineering Group**

**APPROVED:** [Signature]

**DATE:** 9/6/2017

**PROJECT:** WALNUT CREEK SEC. 14 DRAINAGE AREA MAP AND POLLUTION PREVENTION PLAN

**DATE:** 5 of 24

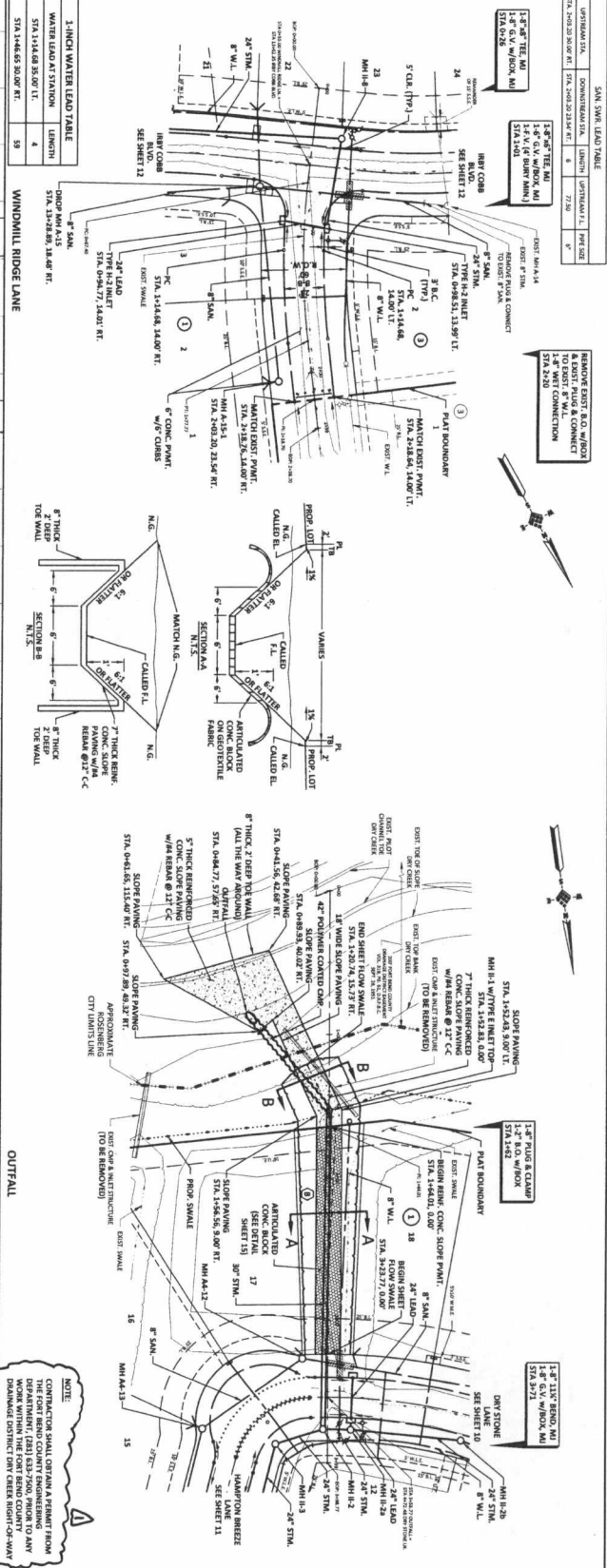
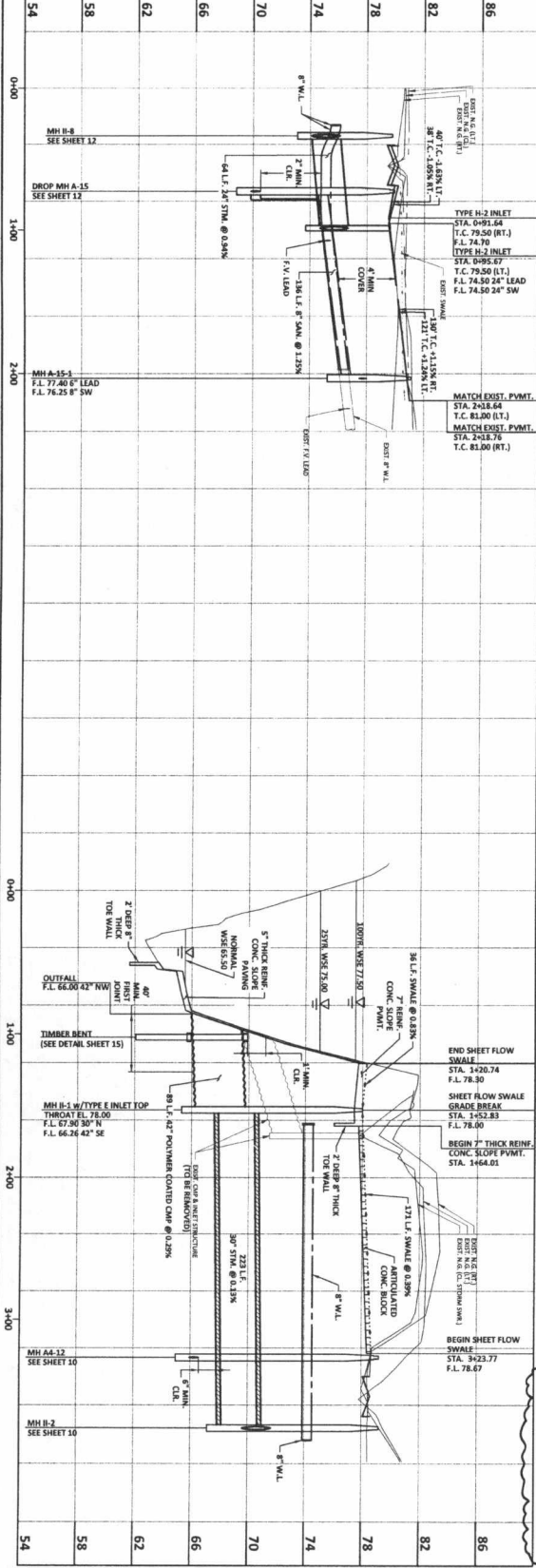
**SCALE:** 1"=400'

**SECTION A-A**

**SECTION B-B**







VERT. 1" = 4'	8' of 24'
HORIZ. 1" = 40'	

105 Drawing No.

**WALNUT CREEK SEC. 14**  
**PLAN AND PROFILE**  
**WINDMILL RIDGE LANE**  
**AND OUTFALL**

**CITY OF ROSENBERG**

**Engineering Group**

**10/17/2017**

**APPROVED: [Signature]**

**DATE: 10/17/17**

**DESIGNED: [Signature]**

**CHECKED: [Signature]**

**DATE: JUNE 2017**

**PROJECT: WALNUT CREEK SEC. 14**

**CONTRACT NO. 14-000000-0000**

**CONTRACTOR: [Name]**

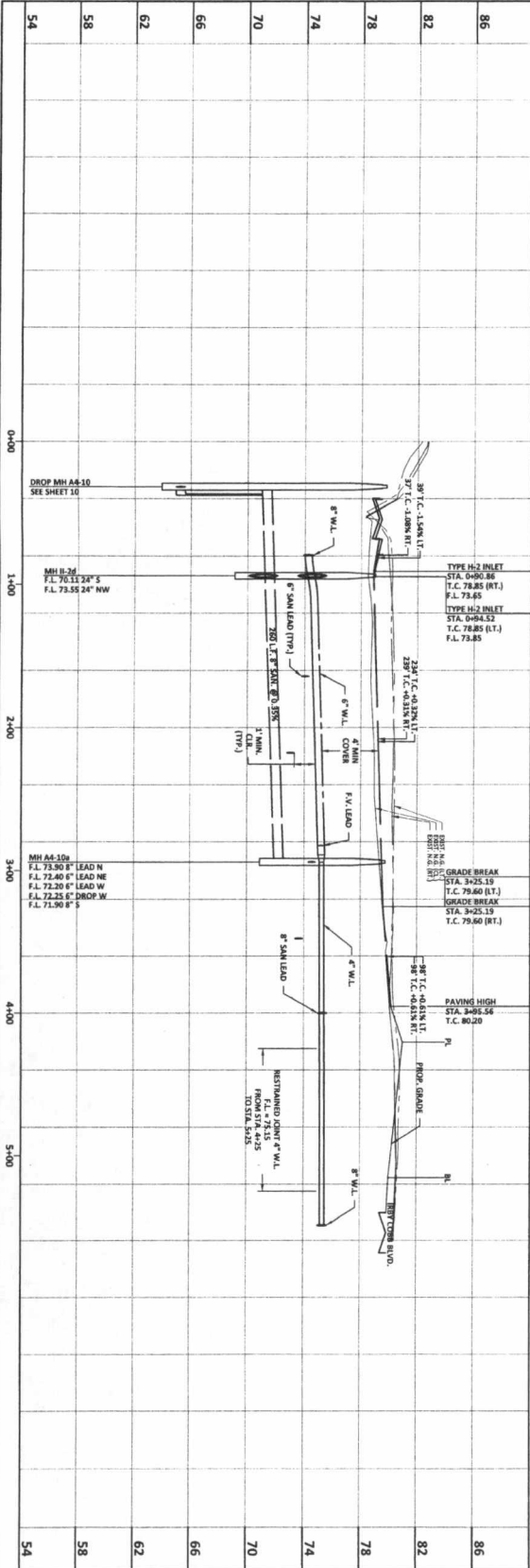
**ENGINEER: [Name]**

**SCALE: 1" = 40'**

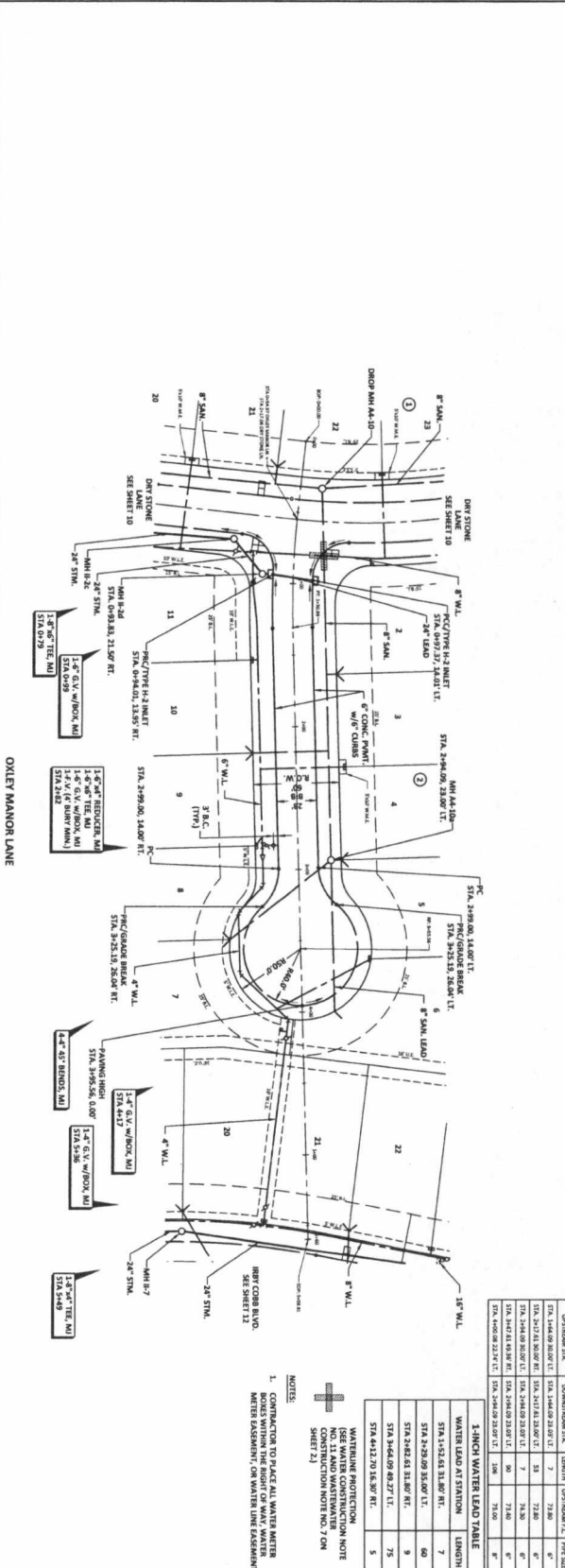
**NOTES:**

- CONTRACTOR TO PLACE ALL WATER METER BOXES WITHIN WATER MAINS AND/OR WATER LINE EASEMENT.
- WATERLINE PROTECTION (SEE WATER PROTECTION CONSTRUCTION NOTE NO. 7 ON SHEET 2)

**ADD NOTE**



STATION	DESCRIPTION	LENGTH	UNITARY L.	UNITARY L.
54	1.5" G.W. W/BOX, MI	7.00	7.00	7.00
58	1.5" G.W. W/BOX, MI	7.00	7.00	7.00
62	1.5" G.W. W/BOX, MI	7.00	7.00	7.00
66	1.5" G.W. W/BOX, MI	7.00	7.00	7.00
70	1.5" G.W. W/BOX, MI	7.00	7.00	7.00
74	1.5" G.W. W/BOX, MI	7.00	7.00	7.00
78	1.5" G.W. W/BOX, MI	7.00	7.00	7.00
82	1.5" G.W. W/BOX, MI	7.00	7.00	7.00



STATION	DESCRIPTION	LENGTH	UNITARY L.	UNITARY L.
54	1.5" G.W. W/BOX, MI	7.00	7.00	7.00
58	1.5" G.W. W/BOX, MI	7.00	7.00	7.00
62	1.5" G.W. W/BOX, MI	7.00	7.00	7.00
66	1.5" G.W. W/BOX, MI	7.00	7.00	7.00
70	1.5" G.W. W/BOX, MI	7.00	7.00	7.00
74	1.5" G.W. W/BOX, MI	7.00	7.00	7.00
78	1.5" G.W. W/BOX, MI	7.00	7.00	7.00
82	1.5" G.W. W/BOX, MI	7.00	7.00	7.00

**WATERLINE PROTECTION**  
 (SEE WATER CONSTRUCTION NOTE  
 CONSTRUCTION NOTE NO. 7 ON  
 SHEET 2)

**1-INCH WATER LEAD TABLE**

WATER LEAD AT STATION	LENGTH	UNITARY L.	UNITARY L.
STA. 1-05.43 13.00' FT.	7	7.00	7.00
STA. 2-25.09 33.00' FT.	60	60.00	60.00
STA. 2-42.63 31.00' FT.	9	9.00	9.00
STA. 3-44.09 49.27' FT.	75	75.00	75.00
STA. 4-11.20 16.00' FT.	5	5.00	5.00

**NOTES:**

- CONSTRUCTION TO PLACE ALL WATER METER BOXES WITHIN THE RIGHT OF WAY WATER METER EASEMENT, OR WATER LINE EASEMENT.

**IDS Engineering Group**

REGISTERED PROFESSIONAL ENGINEER  
 STATE OF CALIFORNIA  
 LICENSE NO. 61864

DATE: 10/11/17

APPROVED: *[Signature]*  
 PROJECT ENGINEER

**CITY OF ROSENBERG**

PLAN AND PROFILE  
 OXLEY MANOR LANE

**WALNUT CREEK SEC. 14**

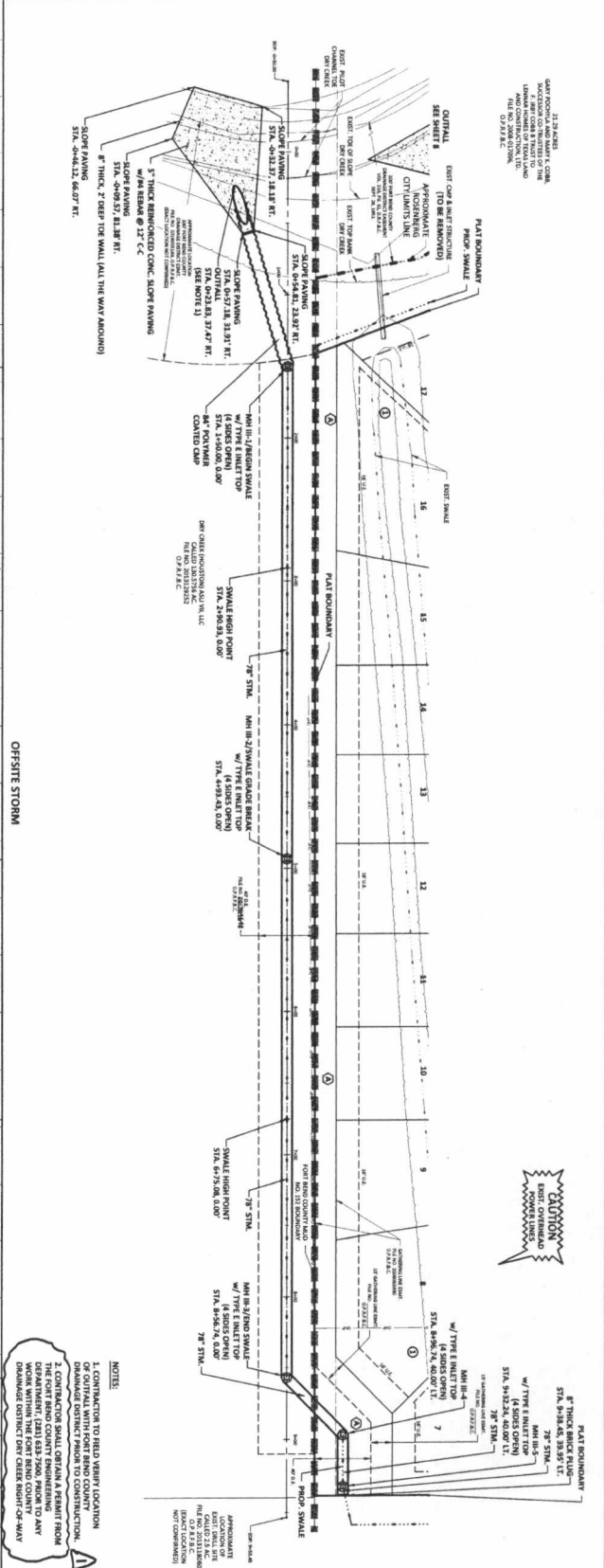
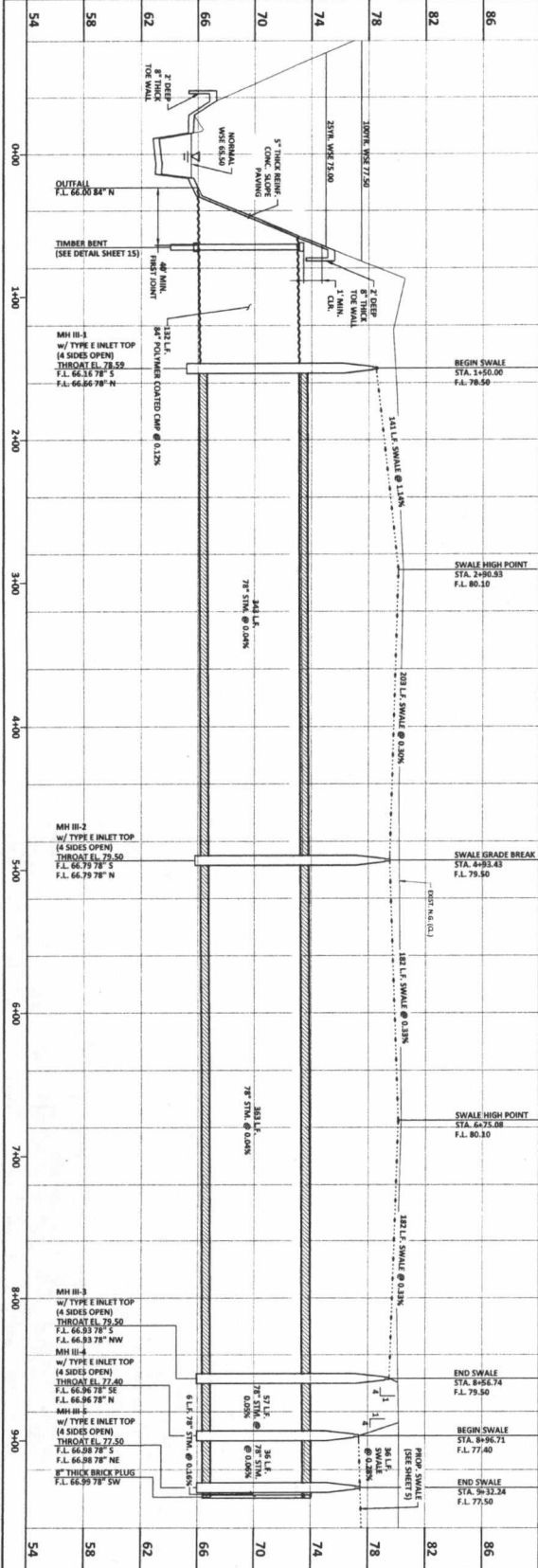
DATE: 11-20-17

SCALE: 1"=40'









**NOTES:**

- CONTRACTOR TO FIELD VERIFY LOCATION
- CONTRACTOR SHALL OBTAIN A PERMIT FROM THE FORT BEND COUNTY ENGINEERING DEPARTMENT WITHIN THE FORT BEND COUNTY DRAINAGE DISTRICT DRY CREEK RIGHT-OF-WAY

**VERIFICATION OF PRIVATE UTILITY LINES**

DATE: 10/17/2017

APPROVED: *[Signature]*

DATE: 10/17/2017

SCALE: 1"=40'

11/10/17 ADD NOTE

**CITY OF ROSENBERG**

**WALNUT CREEK SEC. 14**

**PLAN AND PROFILE**

**OFFSITE STORM**

**Engineering Group**

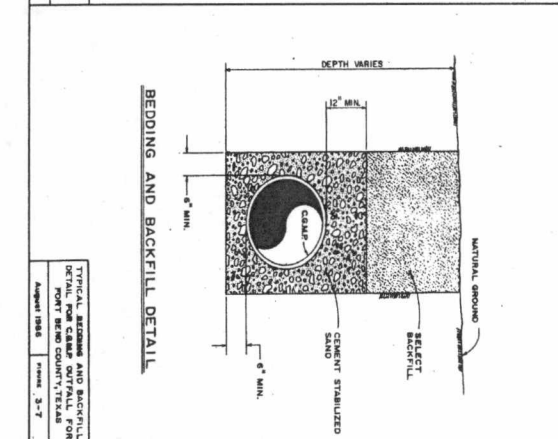
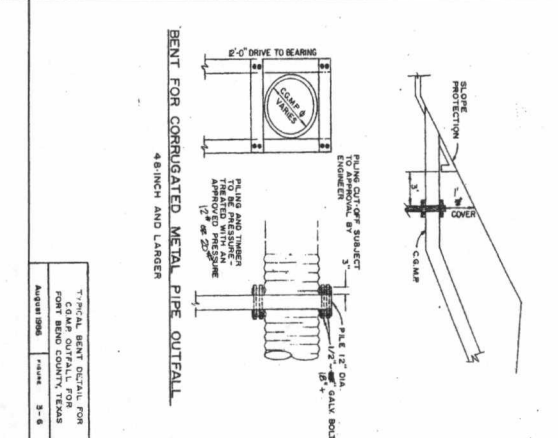
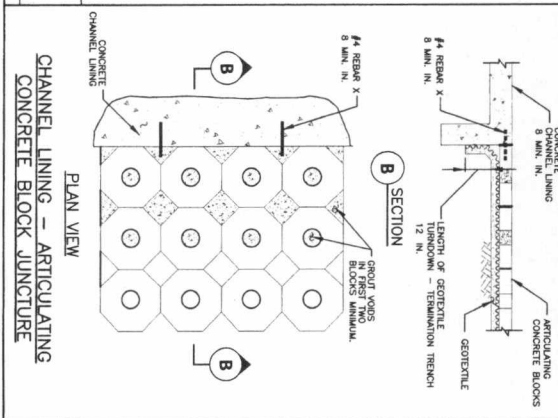
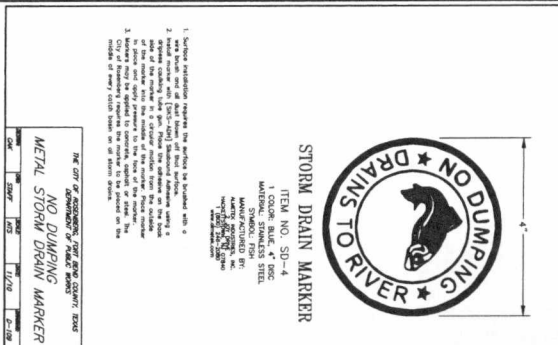
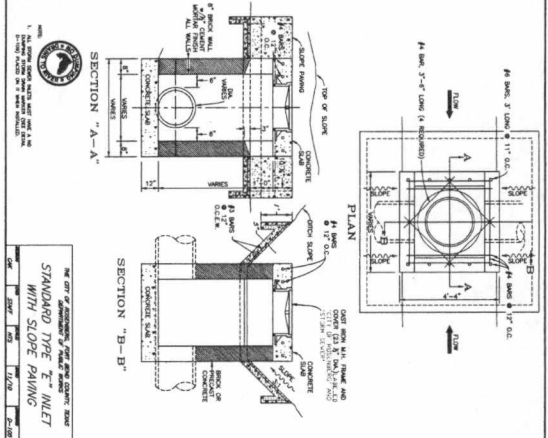
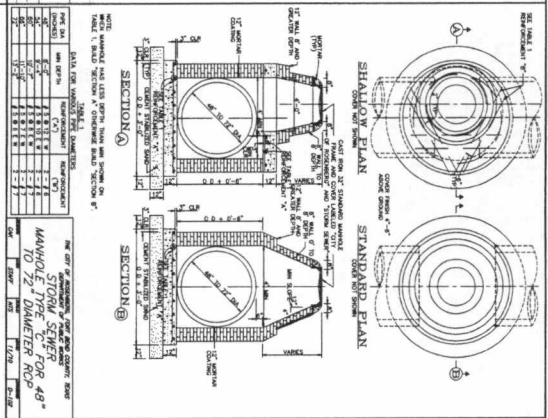
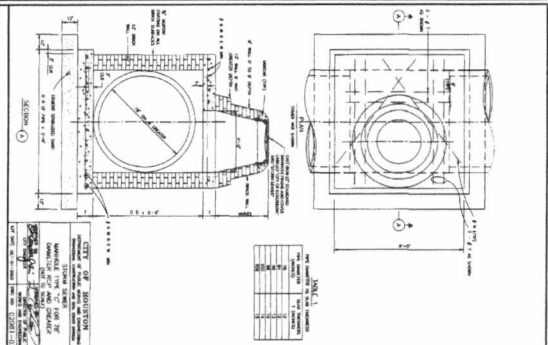
**IDS**

DATE: 10/17/2017

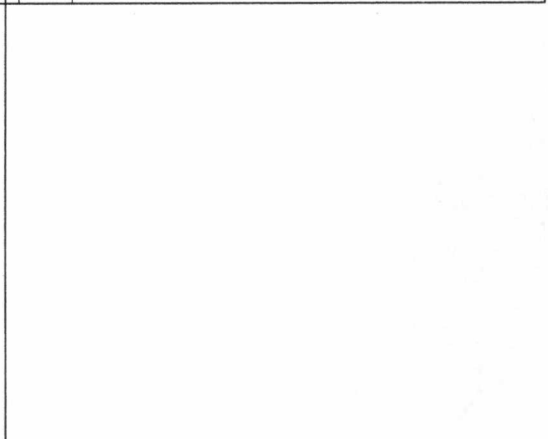
SCALE: 1"=40'

11/10/17 ADD NOTE





<p>7-TYPICAL BENT DETAIL FOR 48\"/&gt; </p>	<p>7-TYPICAL BEDDING AND BACKFILL DETAIL FOR 48\"/&gt; </p>
<p>August 1988</p>	<p>August 1988</p>
<p>3-8</p>	<p>3-7</p>



**IDS**  
Engineering Group

3000  
109504  
7/1/2017

APPROVED: [Signature]  
DATE: 7/1/2017

FOR TOWN ENGINEERING DEPARTMENT  
APPROVED: [Signature]  
DATE: 7/1/2017

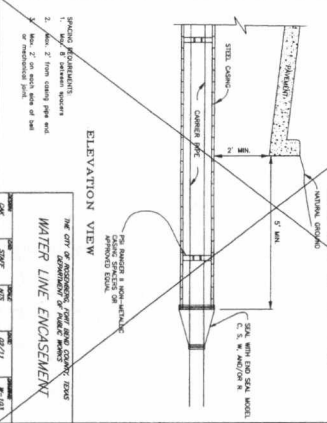
PROJECT NO.	DATE	REVISION





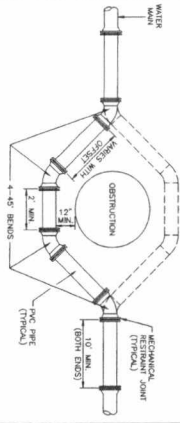
1. Cast the top and bottom ends of the pipe and the reinforcement of the pipe or the reinforcement of the pipe.
2. Reinforce the pipe with the reinforcement of the pipe.
3. Cast the pipe with the reinforcement of the pipe.

CONCRETE	REINFORCEMENT	PIPE DIA. (IN.)	MIN. WALL THICKNESS (IN.)
4"	#4	12"	3.11
6"	#6	18"	3.18
8"	#8	24"	3.20

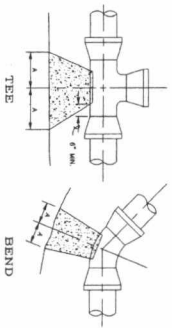


**ELEVATION VIEW**  
**WATER LINE ENCASEMENT**  
 THE CITY OF ROSENBERG, FORT BEND COUNTY, TEXAS  
 PROJECT NO. 1378-029-00  
 SHEET 18 OF 24

1. REINFORCE CONCRETE PER 18, 100 PSI MIN. DESIGN PER CODE.
1. REINFORCE CONCRETE PER 18, 100 PSI MIN. DESIGN PER CODE.
2. PROVIDE 2-1/2" AL-THE-ROUND STAINLESS STEEL ROSS BENDERS ALL FITTINGS.
4. FITTINGS TO BE PROVIDED BY MANUFACTURER OF PIPE JOINTS AND BE CAST AS AN INTEGRAL PART OF THE CONCRETE.
5. REINFORCED STEEL PIPE SECTIONS ARE TO BE CAST AS AN INTEGRAL AS APPROVED BY THE ENGINEER.

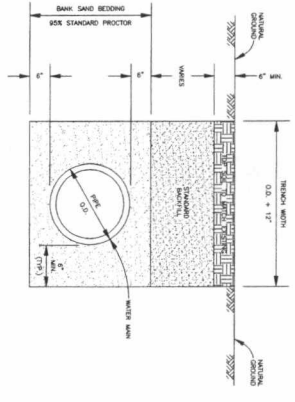


**FIGURE A: LINE TO INSIDE DIA. OF PIPE**  
 THE CITY OF ROSENBERG, FORT BEND COUNTY, TEXAS  
**WATER PIPE OFF-SET ASSEMBLY**  
 PROJECT NO. 1378-029-00  
 SHEET 18 OF 24

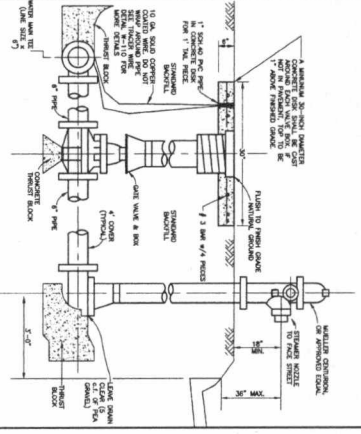


SIZE	FOR RING 1 OF RING 2	12" VENTILATION	TEE	BEND
1 1/2"	1 1/2"	1 1/2"	1 1/2"	1 1/2"
2"	2"	2"	2"	2"
3"	3"	3"	3"	3"
4"	4"	4"	4"	4"
6"	6"	6"	6"	6"
8"	8"	8"	8"	8"
10"	10"	10"	10"	10"
12"	12"	12"	12"	12"
18"	18"	18"	18"	18"
24"	24"	24"	24"	24"

**THRUST BLOCKING DETAILS**  
 THE CITY OF ROSENBERG, FORT BEND COUNTY, TEXAS  
 PROJECT NO. 1378-029-00  
 SHEET 18 OF 24



**WATER MAIN BEDDING & BACKFILL**  
 THE CITY OF ROSENBERG, FORT BEND COUNTY, TEXAS  
 PROJECT NO. 1378-029-00  
 SHEET 18 OF 24



**FINE HYDRANT ASSEMBLY**  
 THE CITY OF ROSENBERG, FORT BEND COUNTY, TEXAS  
 PROJECT NO. 1378-029-00  
 SHEET 18 OF 24

No.	Date	Revisions	App.

FOR BEND COUNTY ENGINEERING DEPARTMENT  
 APPROVED: *[Signature]*  
 DATE: 10/13/18

*Kim A. Hardy*  
 9/16/2017



**IDS Engineering Group**  
 LICENSED PROFESSIONAL ENGINEER  
 STATE OF TEXAS  
 PROJECT NO. 1378-029-00  
 SHEET 18 OF 24

**VERIFICATION OF PRIVATE UTILITY LINES**  
 WALNUT CREEK SEC. 14  
 WATER LINE DETAILS



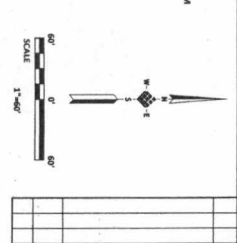
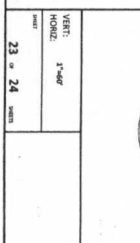
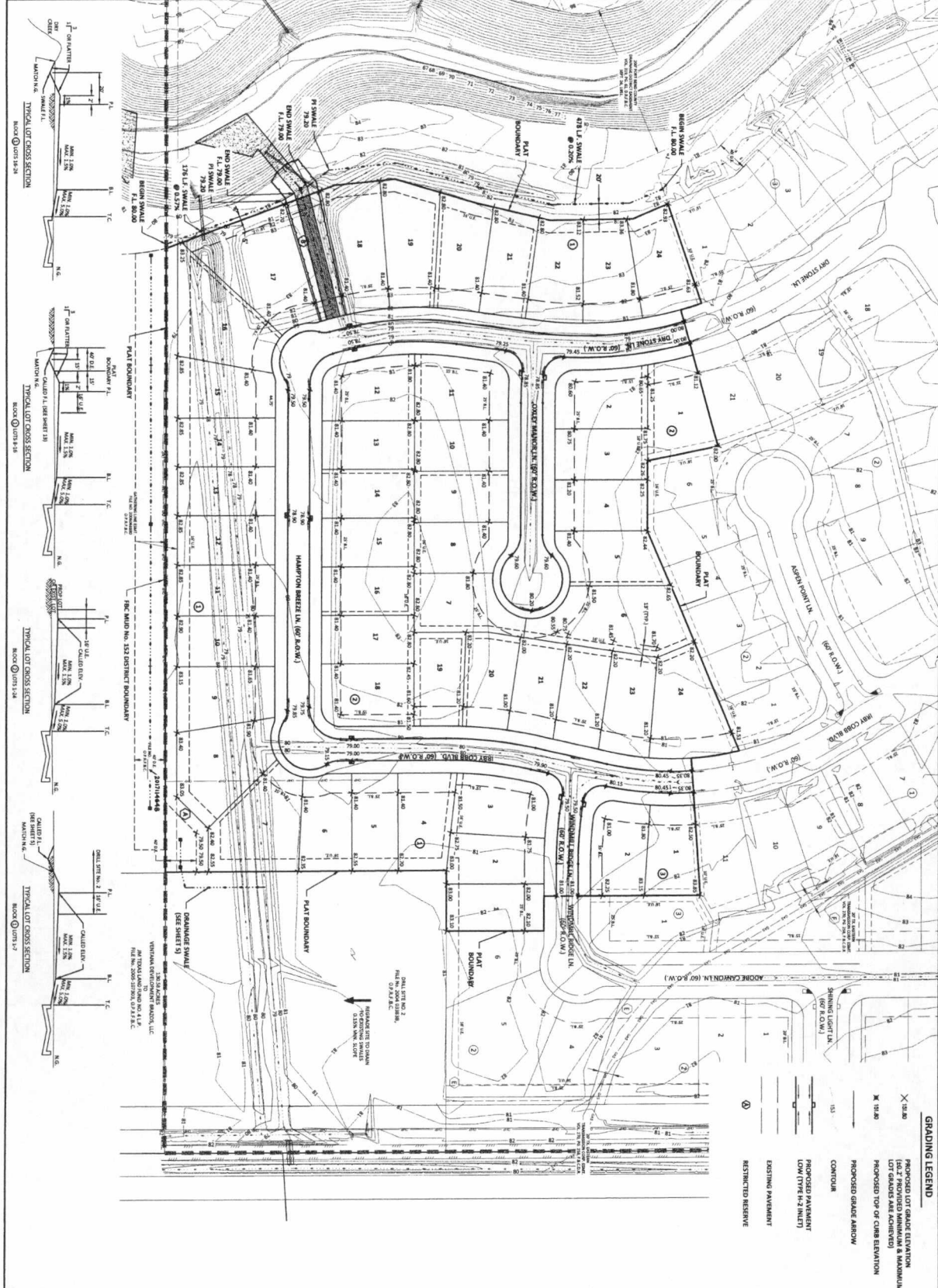
**CITY OF ROSENBERG**  
 PROJECT NO. 1378-029-00  
 SHEET 18 OF 24











**CITY OF ROSENBERG**  
 ENGINEERING DEPARTMENT  
 105 Drawing No. \_\_\_\_\_

**WALNUT CREEK SEC. 14**  
 LOT GRADING PLAN

**IDS**  
 Engineering Group  
 13415 West Loop West, Suite 100  
 Houston, Texas 77040  
 Phone: 281.410.1100  
 Fax: 281.410.1101  
 www.ids-engineering.com

APPROVED: *[Signature]*  
 DATE: 01/11/17

FOR THE CITY OF ROSENBERG  
 APPROVED: *[Signature]*  
 DATE: 01/11/17

VERIFICATION OF PRIVATE UTILITY LINES  
 The undersigned has verified the location and depth of all private utility lines shown on this plan. The location and depth of all private utility lines shown on this plan are based on the records of the City of Rosenberg, Texas, and the records of the utility companies. The location and depth of all private utility lines shown on this plan are based on the records of the City of Rosenberg, Texas, and the records of the utility companies. The location and depth of all private utility lines shown on this plan are based on the records of the City of Rosenberg, Texas, and the records of the utility companies.

