



**REVIEW BY FORT BEND COUNTY
COMMISSIONERS COURT**

**Fort Bend County
Engineering Department**
301 Jackson Suite 401
Richmond, Texas 77469
281.633.7500
Permits@fortbendcountytx.gov

Right of Way Permit
 Commercial Driveway Permit
Permit No: 2017-17255

Applicant: LEM Construction Co., Inc.

Job Location Site: 5600 Riverwood Drive., Richmond, TX 77463

Bond No. **Date of Bond:** 11/21/2017 **Amount:** \$5,000.00

The above applicant came to make use of certain Fort Bend County property subject to, "The Order Regulating the Laying, Construction, Maintenance, and Repair of Buried Cables, Conduits, and Pole Lines, In, Under, Across or Along Roads, Streets, Highways, and Drainage Ditches in Fort Bend County, Texas, Under the Jurisdiction of the Commissioners Court of Fort Bend County, Texas," as passed by the Commissioners Court of Fort Bend County, Texas, of the Minutes of the Commissioners Court of Fort Bend County, Texas, to the extent that such order is not inconsistent with Chapter 181, Vernon's Texas Statutes and Codes Annotated.

Notes:

1. Evidence of review by the Commissioners Court must be kept on the job site and failure to do so constitutes grounds for job shutdown.
2. Written notices are required:
 - a. 48 hours in advance of construction start up, and
 - b. When construction is completed and ready for final inspection, submit notification to Permit Administrator thru MyGovernmentOnline.org portal.
3. This permit expires one (1) year from date of permit if construction has not commenced.

On this 19th day of December, 2017, Upon Motion of Commissioner Meyer, seconded by Commissioner Morales, duly put and carried, it is ORDERED, ADJUDGED AND DECREED that said notice of said above purpose is hereby acknowledged by the Commissioners Court of Fort Bend County, Texas, and that said notice be placed on record according to the regulation order thereof.

Signature

Presented to Commissioners Court and approved.

By: Charles O. AM
for County Engineer

Date Recorded 12-26-2017 Comm. Court No. 13C

By: N/A
Drainage District Engineer/Manager

Clerk of Commissioners Court
By: Arinda Wilkes
Deputy

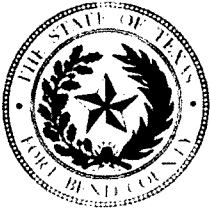

**PERMIT APPLICATION REVIEW FORM FOR
CABLE, CONDUIT, AND POLE LINE ACTIVITY
IN FORT BEND COUNTY**

**Fort Bend County
Engineering Department**
301 Jackson Suite 401
Richmond, Texas 77469
281.633.7500
Permits@fortbendcountytx.gov

- Right of Way Permit
- Commercial Driveway Permit

Permit No: 2017-17255

The following "Notice of Proposed Cable, Conduit, and/or Pole Line activity in Fort Bend County" and accompanying attachments have been reviewed and the notice conforms to appropriate regulations set by Commissioner's Court of Fort Bend County, Texas.

(1) COMPLETE APPLICATION FORM:

- a. Name of road, street, and/or drainage ditch affected.
- b. Vicinity map showing course of directions
- c. Plans and specifications

(2) BOND:

- County Attorney, approval when applicable.
- Perpetual bond currently posted. Bond No: _____ Amount: _____
- Performance bond submitted. Bond No: [REDACTED] Amount: \$5,000.00
- Cashier's Check Check No: _____ Amount: _____

(3) DRAINAGE DISTRICT APPROVAL (WHEN APPLICABLE):

Drainage District Approval

Date

We have reviewed this project and agree it meets minimum requirements.

Chandy O. AM

Permit Administrator

12-8-2017
Date

**PERFORMANCE BOND COVERING ALL CABLE, CONDUIT AND/OR POLE LINE
ACTIVITY IN, UNDER, ACROSS OR ALONG FORT BEND COUNTY ROAD,
COMMERCIAL DRIVEWAY AND MEDIAN OPENINGS OR MODIFICATIONS
(AUTHORIZED)**

BOND NO. [REDACTED]

THE STATE OF TEXAS §
COUNTY OF FORT BEND §

KNOW ALL MEN BY THESE PRESENTS:

THAT WE, LEM Construction Co., Inc. whose (address, phone) is 10849 Kinghurst, Ste. 150, Houston Texas; Ph#(281)495-9550, hereinafter called the Principal, and Liberty Mutual Insurance Company, a Corporation existing under and by virtue of the laws of the state of Texas and authorized to do an indemnifying business in the state of Texas, and whose principal office is located at (name/address/phone) 1600 N. Collins Blvd., Ste. 3000, Richardson, TX 75080; Ph#(800)472-5357, whose officer residing in the State of Texas, authorized to accept service in all suits and actions brought whining said state is Insurepointe of Texas, Inc. and whose address is 2909 Hillcroft, Ste. 600, Houston, TX 77057; Ph#(713)964-0022, hereinafter called the Surety, and held and firmly bound unto , Robert E. Hebert, County Judge of Fort Bend County, Texas, or his successors in office, in the full sum of Five Thousand and No/100 Dollars (\$ 5,000.00) current, lawful money of the United States of America, to be paid to said Robert E. Hebert, County Judge of Fort Bend County, Texas, or his successors in office, to which payment well and truly to be made and done, we, the undersigned, bind ourselves and each of us, our heirs, executors, administrators, successors, assigns, and legal representatives, jointly and severally, by these presents.

THE CONDITION OF THIS BOND IS SUCH THAT, WHEREAS, the above bounden principal contemplates laying, constructing, maintaining and/or repairing one or more cables, conduits, and/or pole lines in, under, across and/or along roads, streets and highways, commercial driveway and median openings or modifications in the County of Fort Bend, and the State of Texas, under the jurisdiction of the Commissioners' Court of Fort Bend County, Texas, pursuant to the Commissioners' Court order adopted on the 1st day of December, A.D. 1980, recorded in Volume 13, of the Commissioners' Court Minutes of Fort Bend County, Texas, regulating same, which Commissioners' Court order is hereby referred to and made a part hereof for all purposes as though fully set out herein;

AND WHEREAS, the principal desires to provide Fort Bend County with a performance bond covering all such cable, conduit and/or pole line activity, commercial driveway and median openings or modifications;

NOW, THEREFORE, if the above bounden principal shall faithfully perform all its cable, conduit and/or pole line activity (including, but not limited to the laying, construction, maintenance and/or repair of cables, conduits and/or pole lines) in, under, across and/or along roads, streets and highways, commercial driveway and median openings or modifications in the County of Fort Bend and State of Texas, under the jurisdiction of the Commissioners Court of Fort Bend County, Texas, pursuant to and in accordance with minimum requirements and conditions of the above mentioned Commissioners' Court order set forth and specified to be by said principal done and performed, at the time and in the manner therein specified, and shall pay over and make good and reimburse Fort Bend County, all loss and damages which Fort Bend County may sustain by reason of any failure or default on the part of said principal, then this obligation shall be null and void, otherwise to remain in full force and effect.

This bond is payable at the County Courthouse in the County of Fort Bend and State of Texas.

It is understood that at any time Fort Bend County deems itself insecure under this bond, it may require further and/or additional bonds of the principal.

EXECUTED this 21st day of November, 2017 .

LEM Construction Co., Inc.
PRINCIPAL

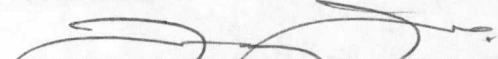
BY Larry W. Laird, II, President

Liberty Mutual Insurance Company
SURETY

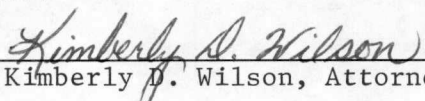
BY Kimberly D. Wilson, Attorney-in-Fact

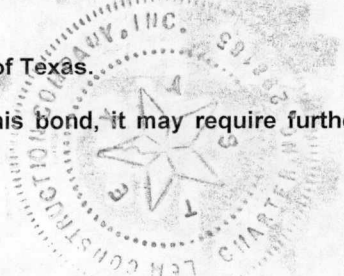
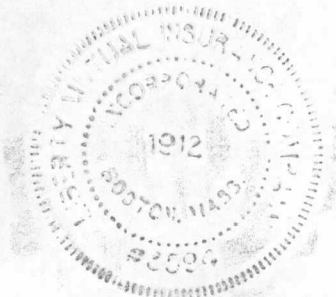

4 pgs
2017140789

CCM 12-19-2017 # 13C
Fort Bend County Clerk
Return Admin Serv Coord. *RAC*
Permit # 201717255

THIS POWER OF ATTORNEY IS NOT VALID UNLESS IT IS PRINTED ON RED BACKGROUND.

This Power of Attorney limits the acts of those named herein, and they have no authority to bind the Company except in the manner and to the extent herein stated.

Certificate No. 7625466

Liberty Mutual Insurance Company
The Ohio Casualty Insurance Company West American Insurance Company

POWER OF ATTORNEY

KNOWN ALL PERSONS BY THESE PRESENTS: That The Ohio Casualty Insurance Company is a corporation duly organized under the laws of the State of New Hampshire, that Liberty Mutual Insurance Company is a corporation duly organized under the laws of the State of Massachusetts, and West American Insurance Company is a corporation duly organized under the laws of the State of Indiana (herein collectively called the "Companies"), pursuant to and by authority herein set forth, does hereby name, constitute and appoint, Carol M. Sweeney; James D. Frith; Karen Brooks; Kimberly D. Wilson; Patricia A. Watson; Susan Palmer

all of the city of Houston, state of TX each individually if there be more than one named, its true and lawful attorney-in-fact to make, execute, seal, acknowledge and deliver, for and on its behalf as surety and as its act and deed, any and all undertakings, bonds, recognizances and other surety obligations, in pursuance of these presents and shall be as binding upon the Companies as if they have been duly signed by the president and attested by the secretary of the Companies in their own proper persons.

IN WITNESS WHEREOF, this Power of Attorney has been subscribed by an authorized officer or official of the Companies and the corporate seals of the Companies have been affixed thereto this 13th day of February, 2017.



The Ohio Casualty Insurance Company
Liberty Mutual Insurance Company
West American Insurance Company
By: David M. Carey
David M. Carey, Assistant Secretary

STATE OF PENNSYLVANIA ss
COUNTY OF MONTGOMERY

On this 13th day of February, 2017, before me personally appeared David M. Carey, who acknowledged himself to be the Assistant Secretary of Liberty Mutual Insurance Company, The Ohio Casualty Company, and West American Insurance Company, and that he, as such, being authorized so to do, execute the foregoing instrument for the purposes therein contained by signing on behalf of the corporations by himself as a duly authorized officer.

IN WITNESS WHEREOF, I have hereunto subscribed my name and affixed my notarial seal at King of Prussia, Pennsylvania, on the day and year first above written.



COMMONWEALTH OF PENNSYLVANIA
Notarial Seal
Teresa Pastella, Notary Public
Upper Merion Twp., Montgomery County
My Commission Expires March 28, 2017
Member, Pennsylvania Association of Notaries

By: Teresa Pastella
Teresa Pastella, Notary Public

This Power of Attorney is made and executed pursuant to and by authority of the following By-laws and Authorizations of The Ohio Casualty Insurance Company, Liberty Mutual Insurance Company, and West American Insurance Company which resolutions are now in full force and effect reading as follows:

ARTICLE IV – OFFICERS – Section 12. Power of Attorney. Any officer or other official of the Corporation authorized for that purpose in writing by the Chairman or the President, and subject to such limitation as the Chairman or the President may prescribe, shall appoint such attorneys-in-fact, as may be necessary to act in behalf of the Corporation to make, execute, seal, acknowledge and deliver as surety any and all undertakings, bonds, recognizances and other surety obligations. Such attorneys-in-fact, subject to the limitations set forth in their respective powers of attorney, shall have full power to bind the Corporation by their signature and execution of any such instruments and to attach thereto the seal of the Corporation. When so executed, such instruments shall be as binding as if signed by the President and attested to by the Secretary. Any power or authority granted to any representative or attorney-in-fact under the provisions of this article may be revoked at any time by the Board, the Chairman, the President or by the officer or officers granting such power or authority.

ARTICLE XIII – Execution of Contracts – SECTION 5. Surety Bonds and Undertakings. Any officer of the Company authorized for that purpose in writing by the chairman or the president, and subject to such limitations as the chairman or the president may prescribe, shall appoint such attorneys-in-fact, as may be necessary to act in behalf of the Company to make, execute, seal, acknowledge and deliver as surety any and all undertakings, bonds, recognizances and other surety obligations. Such attorneys-in-fact subject to the limitations set forth in their respective powers of attorney, shall have full power to bind the Company by their signature and execution of any such instruments and to attach thereto the seal of the Company. When so executed such instruments shall be as binding as if signed by the president and attested by the secretary.

Certificate of Designation – The President of the Company, acting pursuant to the Bylaws of the Company, authorizes David M. Carey, Assistant Secretary to appoint such attorneys-in-fact as may be necessary to act on behalf of the Company to make, execute, seal, acknowledge and deliver as surety any and all undertakings, bonds, recognizances and other surety obligations.

Authorization – By unanimous consent of the Company's Board of Directors, the Company consents that facsimile or mechanically reproduced signature of any assistant secretary of the Company, wherever appearing upon a certified copy of any power of attorney issued by the Company in connection with surety bonds, shall be valid and binding upon the Company with the same force and effect as though manually affixed.

I, Renee C. Llewellyn, the undersigned, Assistant Secretary, The Ohio Casualty Insurance Company, Liberty Mutual Insurance Company, and West American Insurance Company do hereby certify that the original power of attorney of which the foregoing is a full, true and correct copy of the Power of Attorney executed by said Companies, is in full force and effect and has not been revoked.

IN TESTIMONY WHEREOF, I have hereunto set my hand and affixed the seals of said Companies this 21st day of November, 20 17.



By: Renee C. Llewellyn
Renee C. Llewellyn, Assistant Secretary

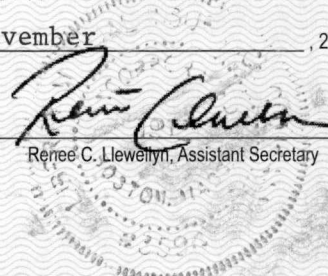

Not valid for mortgage, note, loan, letter of credit, currency rate, interest rate or residual value guarantees.

To confirm the validity of this Power of Attorney call 1-610-832-8240 between 9:00 am and 4:30 pm EST on any business day.



TEXAS IMPORTANT NOTICE

To obtain information or make a complaint:

You may call toll-free for information or to make a complaint at
1-877-751-2640

You may also write to:

2200 Renaissance Blvd., Ste. 400
King of Prussia, PA 19406-2755

You may contact the Texas Department of Insurance to obtain information on companies, coverages, rights or complaints at
1-800-252-3439

You may write the Texas Department of Insurance
Consumer Protection (111-1A)
P. O. Box 149091
Austin, TX 78714-9091
FAX: (512) 490-1007
Web: <http://www.tdi.texas.gov>
E-mail: ConsumerProtection@tdi.texas.gov

PREMIUM OR CLAIM DISPUTES:

Should you have a dispute concerning your premium or about a claim you should first contact the agent or call 1-800-843-6446. If the dispute is not resolved, you may contact the Texas Department of Insurance.

ATTACH THIS NOTICE TO YOUR POLICY:

This notice is for information only and does not become a part or condition of the attached document.

TEXAS AVISO IMPORTANTE

Para obtener informacion o para someter una queja:

Usted puede llamar al numero de telefono gratis para informacion o para someter una queja al
1-877-751-2640

Usted tambien puede escribir a:

2200 Renaissance Blvd., Ste. 400
King of Prussia, PA 19406-2755

Puede comunicarse con el Departamento de Seguros de Texas para obtener informacion acerca de companias, coberturas, derechos o quejas al
1-800-252-3439

Puede escribir al Departamento de Seguros de Texas Consumer Protection (111-1A)
P. O. Box 149091
Austin, TX 78714-9091
FAX # (512) 490-1007
Web: <http://www.tdi.texas.gov>
E-mail: ConsumerProtection@tdi.texas.gov

DISPUTAS SOBRE PRIMAS O RECLAMOS:

Si tiene una disputa concerniente a su prima o a un reclamo, debe comunicarse con el agente o primero. Si no se resuelve la disputa, puede entonces comunicarse con el departamento (TDI)

UNA ESTE AVISO A SU POLIZA:

Este aviso es solo para proposito de informacion y no se convierte en parte o condicion del documento adjunto.

FILED AND RECORDED
OFFICIAL PUBLIC RECORDS

Laura Richard

Laura Richard, County Clerk

Fort Bend County Texas

December 26, 2017 02:34:53 PM

FEE: \$0.00 ER

2017140789



DRILL AND EPOXY
DOWELS INTO EXISTING
PAVEMENT AT 18" O.C.

JOINT SEAL AS
PER DETAIL

#4 BARS AT
18" O.C.E.W.

7" THICK,
3,500 PSI
CONCRETE

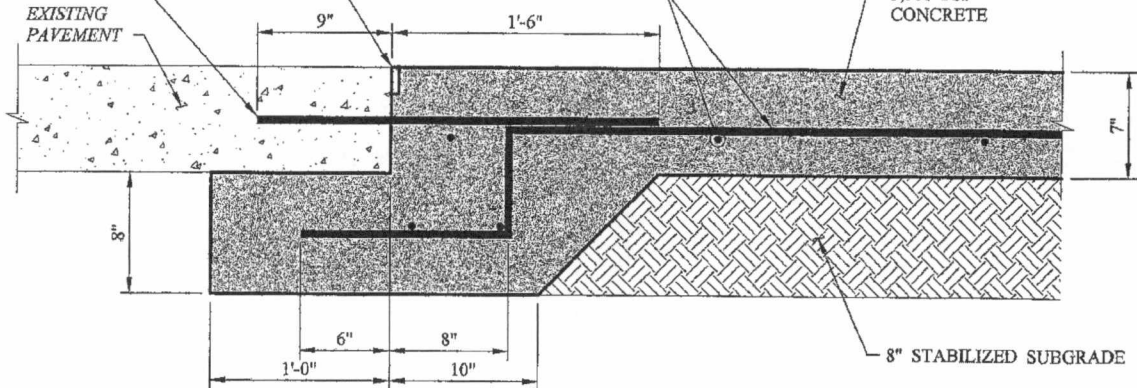

**DRIVEWAY CONNECTION
TO EXISTING STREET**

NO SCALE

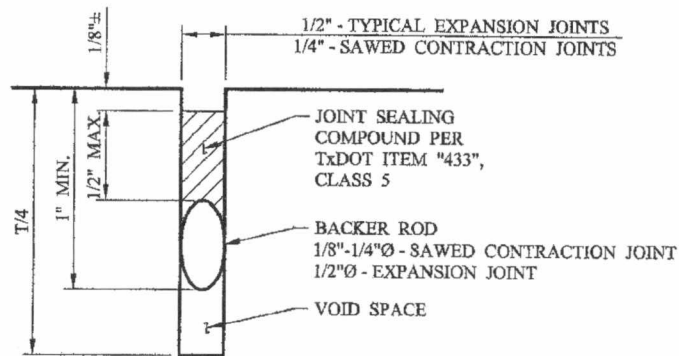

JOINT SEAL NOTES:

1. BACKER RODS SHALL BE COMPATIBLE WITH THE CLASS OF SEALANT USED.
2. T = SLAB THICKNESS.

TYPICAL JOINT SEAL

NO SCALE

11/15/2017



Jonathan Baum



ENPROTEC/HIBBS & TODD, INC.

ENVIRONMENTAL AND CIVIL ENGINEERING
402 Cedar Street
325-698-5900
Albion, Texas 77601
PE Firm Registration No. 1151
PC Firm Registration No. 50108
RPLS Firm Registration Nos. 10011900 & 10007300

DRIVEWAY DETAIL

CITY OF RICHMOND, TEXAS
RICHMOND WATER SURFACE TREATMENT PLANT

14-6021

11/15/2017

