

STANDARD UTILITY AGREEMENT

U-0017: CyrusOne
 County: Fort Bend
 Highway: FM 1093 Westpark Extension

This Agreement by and between the County of Fort Bend, Texas, ("**County**"), and **CyrusOne**, ("**Utility**"), acting by and through its duly authorized representative, shall be effective on the date of approval and execution by and on behalf of the **County**.

WHEREAS, the **County** has deemed it necessary to make certain highway improvements as designated by the **County** and approved by the Federal Highway Administration within the limits of the highway as indicated above;

WHEREAS, the proposed highway improvements will necessitate the adjustment, removal, and/or relocation of certain facilities of **Utility** as indicated in the following statement of work: relocation of assets into a predesignated corridor according to the following schedule:

Start Date – March 28, 2016
 Completion Date – May 16, 2016

and more specifically shown in **Utility's** Plans and Specifications, Estimated Costs, and Schedule which are attached hereto as Exhibits "A," "B" and "C."

WHEREAS, Subchapter E of Chapter 203 of the Texas Transportation Code regarding the relocation of utilities does not apply to this Project, but the County wishes to negotiate in good faith and enter into agreements with all affected utility companies for the participation in the costs of the adjustment, removal, and/or relocation of certain facilities as authorized under such subchapter.



WHEREAS, the **County**, upon receipt of evidence it deems sufficient, acknowledges **Utility's** interest in certain lands and/or facilities and determined it is appropriate to enter an agreement with **Utility** to govern the terms for participation in the costs of the adjustment, removal, and relocation of certain of its facilities located upon the lands as indicated in the statement of work above.

NOW, THEREFORE, BE IT AGREED:

The **County** will pay to **Utility** fifty percent (50%) of the documented actual costs incurred for relocation of the utility in adjustment, removal, and/or relocation of **Utility's** facilities up to the amount said costs may be eligible for **County** participation.

All conduct under this agreement, including but not limited to the adjustment, removal and relocation of the facility, the development and reimbursement of costs, any environmental requirements, and retention of records will be in accordance with all applicable federal and state laws, rules and regulations, including, without limitation, the Federal Uniform Relocation Assistance and Real Property Acquisition Policies Act, 42 U.S.C. §§ 4601, et seq., the National Environmental Policy Act, 42 U.S.C. §§ 4231, et seq., the Buy America provisions of 23 U.S.C. § 313 and 23 CFR 635.410, the Utility Relocations, Adjustments, and Reimbursements provisions of 23 CFR 645, Subpart A, and with the Utility Accommodation provisions of 23 CFR 645, Subpart B. **Utility** shall supply, upon request by the **County**, proof of compliance with the aforementioned laws, rules and regulations prior to the commencement of construction.

The **Utility** agrees to develop relocation or adjustment costs by accumulating actual direct and related indirect costs in accordance with a work order accounting procedure prescribed by **County**, or may, with the **County's** approval, accumulate actual direct and related indirect costs in accordance with an established accounting procedure developed by **Utility**. Bills for work hereunder will be submitted to **County** not later than 90 days after completion of the work.

 <u>3/30/16</u> Date	 <u>3/29/16</u> Date
Fort Bend County	CyrusOne

4/11/2016 - Original sent to Jillian Peterson, Engineering

When requested, the **County** will make intermediate payments at not less than monthly intervals to **Utility** when properly billed and such payments will not exceed 90 percent (90%) of the eligible cost as shown in each such billing. Intermediate payments shall not be construed as final payment for any items included in the intermediate payment.

Upon execution of this agreement by both parties hereto, the **County** will, by written notice, authorize the **Utility** to perform such work diligently, and to conclude said adjustment, removal, or relocation by the stated completion date. The completion date shall be extended for delays caused by events outside **Utility's** control, including an event of Force Majeure, which shall include a strike, war or act of war (whether an actual declaration of war is made or not), insurrection, riot, act of public enemy, accident, fire, flood or other act of God, sabotage, or other events, interference by the **County** or any other party with **Utility's** ability to proceed with the relocation, or any other event in which **Utility** has exercised all due care in the prevention thereof so that the causes or other events are beyond the control and without the fault or negligence of **Utility**.

The **County** will, upon satisfactory completion of the relocation or adjustment and upon receipt of final billing prepared in an approved form and manner, make payment in the amount of 90 percent (90%) of the eligible costs as shown in the final billing prior to audit and after such audit shall make an additional final payment totaling the reimbursement amount found eligible for **County** reimbursement.

Unless an item below is stricken and initialed by the **County and Utility**, this agreement in its entirety consists of the following:

1. Standard Utility Agreement;
2. Plans & Specifications (Attachment "A");
3. Utility Construction Cost Estimate (Attachment "B");
4. Utility's Schedule of Work and Estimated Date of Completion (Attachment "C").

All attachments are included herein as if fully set forth. In the event it is determined that a substantial change from the statement of work contained in this agreement is required, reimbursement therefore shall be limited to costs covered by a modification or amendment of this agreement or a written change or extra work order approved by the **County and Utility**.

This agreement is subject to cancellation by the **County** at any time up to the date that work under this agreement has been authorized and that such cancellation will not create any liability on the part of the **County**. However, the **County** will review and reimburse the **Utility** for eligible costs incurred by the **Utility** in preparation of this Agreement.

LIMITATIONS OF LIABILITY. NEITHER PARTY SHALL BE LIABLE IN ANY COURT ACTION INITIATED BY A PARTY OR ANY THIRD PARTY FOR ANY INDIRECT, CONSEQUENTIAL, SPECIAL, INCIDENTAL, RELIANCE, OR PUNITIVE DAMAGES OF ANY KIND OR NATURE WHATSOEVER, INCLUDING, WITHOUT LIMITATION, ANY LOST PROFITS, LOST REVENUE, LOST SAVINGS OR ANY OTHER BUSINESS LOSS INCLUDING GOODWILL, LOSS OF USE OF PROPERTY, LOSS OF DATA, AND CLAIMS FOR DAMAGES OR HARM TO BUSINESS REGARDLESS OF FORSEEABILITY OR WHETHER DAMAGES ARE CAUSED BY THE NEGLIGENCE, INTENTIONAL ACTS OR OMISSIONS OR WILLFUL MISCONDUCT ARISING FROM OR RELATED TO THIS AGREEMENT, DIRECTLY OR INDIRECTLY. NOTWITHSTANDING THE FOREGOING, UTILITY SHALL BE LIABLE FOR ANY COSTS COUNTY IS OBLIGATED TO PAY UNDER A CONSTRUCTION AGREEMENT WITH A THIRD PARTY DUE TO DELAYS CAUSED BY THE SOLE NEGLIGENCE OF UTILITY'S FAILURE TO COMPLETE WORK BY STATED COMPLETION DATE.

The **Utility** acknowledges to and for the benefit of the **County** and State of Texas that it understands the project under this Agreement is eligible for Federal-aid highway funds and as such, requires all of the iron, steel, and manufactured goods used in the project be produced in the United States ("Buy American Requirements") including iron, steel, and manufactured goods provided by the **Utility** pursuant to this Agreement.

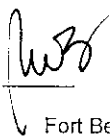
Date 3/30/16
Fort Bend County

GA
Initial
3/29/16
Date
CyrusOne

The State Auditor may conduct an audit or investigation of any entity receiving funds from the **County** directly under this contract or indirectly through a subcontract under this contract. Acceptance of funds directly under this contract or indirectly through a subcontract under this contract acts as acceptance of the authority of the State Auditor, under the direction of the Legislative Audit Committee, to conduct an audit or investigation in connection with those funds. An entity that is the subject of an audit or investigation must provide the state auditor with access to any information the state auditor considers relevant to the investigation or audit.

Any audit performed by the State Auditor under this Agreement shall be under the authority of and consistent with the provisions of Chapter 321 of the Texas Government Code

The **Utility** by execution of this agreement does not waive any of the rights which **Utility** may have within the limits of the law.

It is expressly understood that the **Utility** conducts the adjustment, removal, or relocation at its own risk, and that Fort Bend County, Texas makes no warranties or representations regarding the existence or location of utilities currently within its right of way.

The signatories to this agreement warrant that each has the authority to enter into this agreement on behalf of the party represented.

UTILITY

Utility: CyrusOne
Name of Utility

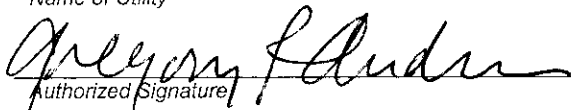
By: 
Authorized Signature

Gregory Andrews
Print or Type Name

Title: Chief financial Officer

Date: March 29, 2016

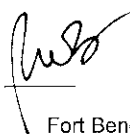
 3/30/16
Date
Fort Bend County

GA 3/29/16
Initial *Date*
CyrusOne

EXECUTION RECOMMENDED:

COUNTY

By:

Robert E. Hebert
Robert E. Hebert, County Judge

Date:

April 5, 2016

ATTEST:

By:

Laura Richard
Laura Richard, County Clerk

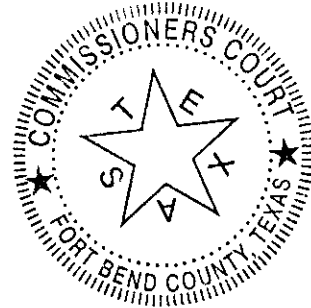

APPROVED:

By:

Richard W. Stolleis
Richard W. Stolleis, P.E., County Engineer

APPROVED AS TO LEGAL FORM:

By:

Marcus D. Spencer
Marcus D. Spencer, First Assistant County Attorney

AUDITOR'S CERTIFICATE

I hereby certify that funds are available in the amount of \$175,860.⁶⁸ to accomplish and pay the obligation of Fort Bend County under this contract.

Robert Ed Sturdivant

Robert Ed Sturdivant, County Auditor

WS 3/30/16
Date
Fort Bend County

GA 3/29/16
Initial Date
CyrusOne

Exhibit A

CyrusOne Plans & Specifications

(62 Pages that Follow)

WS 3/30/16
Date
Fort Bend County

GA 3/29/16
Initial Date
CyrusOne

ADDRESS: FM 1093 WEST OF GRAND PARKWAY
 PROJECT NAME: FM 1093 / WESTPARK EXTENSION RELO

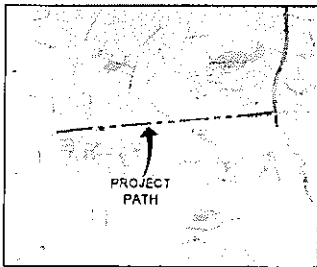

LOCATION MAP

PROJECT LOCATION
 MAP NOT TO SCALE

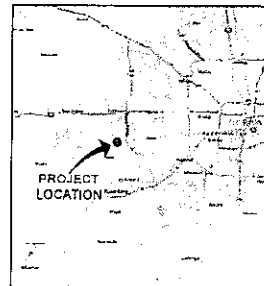

VICINITY MAP

CONTACTS

LEVEL (3)
 4678 HALL #12-544-8013
 GOLDEN FIELD SERVICES
 6846 BRACKER #03-357-5322

PROJECT INDEX

1 - COVER SHEET
 2 - LEGEND
 2A - GENERAL NOTES 1
 2B - GENERAL NOTES 2
 3 - INDEX SHEET
 4-33 - CONSTRUCTION PLANS & PROFILES
 12A-100 - CONSTRUCTION SCHEDULE
 100 - LEVEL 3 CABLE PULLING SCHEMATIC
 11 - TAKE OFF TOTAL

SCOPE OF WORK

REMOVE AND REPLACE 14,177' OF THE EXISTING LEVEL 1 COMMUNICATIONS FIBER NETWORK & PLACE 847 MORE CONDUITS & 21 MANHOLES IN THE NORTH RIGHT-OF-WAY OF FM 1093 & WESTPARK TOLLWAY DUE TO CITY OF HOUSTON INFRASTRUCTURE EXPANSION OF WESTPARK TOLLWAY

PROJECT DESCRIPTION

GLS CODE: P4100000
 ADDRESS: 4678 HALL
 COUNTY: HARRIS COUNTY
 CITY: HOUSTON, TX 77030
 PROJECT NUMBER: 2018-1000
 CUSTOMER/CLIENT: TARRANT ENERGY

1			
2			
3			
NO.	DATE	BY	DESCRIPTION
2-23-18		AL-IBAT	REVISION 1/3
11-14-13		ORIGINAL	
DRAWING		EQUIPMENT	

Level(3)
 ENGINEERS

LEVEL 3 ENGINEER
 4678 HALL
 HOUSTON, TX 77030
 ENGINEERING FIRM
 GOLDEN FIELD SERVICES
 PROJECT NUMBER
 LOCATION: FM 1093 WESTPARK EXTENSION - HOUSTON, TX
 CONTRACTOR

SHEET 1 OF 31
 CDTA 02/11/2018 09:21:44 AM

GENERAL NOTES 2

GENERAL CONSTRUCTION NOTES

1. WASTEWATER COLLECTION SYSTEMS, WATER LINES, STORM DRAINAGE AND STREET PAVING ARE DESIGNED IN ACCORDANCE WITH THE LATEST EDITION OF THE DOCUMENTS "STANDARD CONSTRUCTION SPECIFICATION FOR WASTEWATER COLLECTION SYSTEMS, WATER LINES, STORM DRAINAGE AND STREET PAVING", "STANDARD CONSTRUCTION DETAILS FOR WASTEWATER COLLECTION SYSTEMS, WATER LINES, STORM DRAINAGE AND STREET PAVING" AND THE "INFRASTRUCTURE DESIGN MANUAL" PUBLISHED BY THE CITY OF HOUSTON, DEPARTMENT OF PUBLIC WORKS AND ENGINEERING (OCTOBER 2011)
2. ALL UTILITIES PRESENTED ON THESE DRAWINGS ARE SHOWN BASED ON THE BEST AVAILABLE INFORMATION. CONTRACTOR SHALL VERIFY IN THE FIELD THE EXACT LOCATIONS OF ALL UTILITIES PRIOR TO COMMENCING CONSTRUCTION. CONTRACTOR SHALL NOTIFY TEXAS ONE-CALL @ 800-543-6055 AND HOUSTON'S UTILITY COORDINATING COMMITTEE @ 713-223-4567 AT LEAST 48 HOURS BEFORE PROCEEDING WITH ANY EXCAVATION.
3. THE CONTRACTOR SHALL BE FULLY RESPONSIBLE FOR ANY DAMAGES TO EXISTING WATER, WASTEWATER, STORM WATER, AND TRAFFIC CONTROL DEVICES. ALL DAMAGES SHALL BE REPAIRED IN ACCORDANCE WITH THE CITY OF HOUSTON DEPARTMENT OF PUBLIC WORKS AND ENGINEERING'S "STANDARD CONSTRUCTION SPECIFICATIONS" REFERENCED ABOVE, AT NO COST TO THE CITY OF HOUSTON.
4. CONTRACTOR SHALL NOTIFY THE CITY OF HOUSTON, DEPARTMENT OF PUBLIC WORKS AND ENGINEERING, OFFICE OF THE CITY ENGINEER, 48 HOURS BEFORE STARTING WORK ON THIS PROJECT @ 832-394-0058.
5. ADEQUATE DRAINAGE SHALL BE MAINTAINED AT ALL TIMES DURING CONSTRUCTION AND ANY DRAINAGE DITCH OR STRUCTURE DISTURBED DURING CONSTRUCTION SHALL BE RESTORED TO THE SATISFACTION OF THE OWNING AUTHORITY.
6. CONTRACTOR SHALL TAKE NECESSARY PRECAUTIONS TO PROTECT ROOT SYSTEMS OF SHRUBS, PLANTS AND TREES ALONG THE AREA OF EXCAVATION.
7. THE CONTRACTOR SHALL COMPLY WITH THE LATEST EDITION OF OSHA REGULATION AND THE STATE OF TEXAS LAWS CONCERNING EXCAVATION.
8. IF THE CONSTRUCTION DOES NOT BEGIN WITHIN A YEAR AFTER THE PLANS HAVE BEEN SIGNED, NEW SIGNATURES MUST BE OBTAINED AND LETTERS OF AVAILABILITY MUST BE UPDATED.
9. CONTRACTOR SHALL PREPARE A SET OF "AS-BUILT" DRAWINGS SHOWING ANY FIELD CHANGES MADE TO THE APPROVED ENGINEERING PLANS AND SUBMIT TO THE DESIGN CONSULTANT FOR SUBMISSION TO THE CITY ENGINEER.
10. THE PROJECT IS SUBJECT TO THE CITY OF HOUSTON STREET CUT CANCELLANCE.

CONTRACTOR NOTE

1. THE INFORMATION SHOWN ON THESE DRAWINGS WAS OBTAINED FROM AVAILABLE PUBLIC CITY INFORMATION. ALL INFORMATION CONCERNING TYPE AND LOCATION OF UNDERGROUND UTILITIES IS NOT GUARANTEED TO BE ACCURATE OR ALL INCLUSIVE. THE CONTRACTOR IS RESPONSIBLE FOR MAKING HIS OWN DETERMINATIONS AS TO TYPE AND LOCATION OF UNDERGROUND UTILITIES AS MAY BE NECESSARY TO AVOID DAMAGE THERETO. THE CONTRACTOR SHALL VERIFY LOCATION OF UNDERGROUND PIPELINES, CONDUITS AND STRUCTURES BY CONTACTING OWNERS OF UNDERGROUND UTILITIES OR BY EXCAVATING IN ADVANCE OF CONSTRUCTION.
2. THE CONTRACTOR IS RESPONSIBLE FOR DETERMINING THE EXACT LOCATION OF ALL UTILITIES WHEN AND WHERE THEY FALL IN THE PATH OF CONSTRUCTION.
3. THE CONTRACTOR IS ALSO RESPONSIBLE FOR CONTACTING THE CITY'S UTILITY COORDINATING COMMITTEE @ 713-223-4567 AND TEXAS ONE-CALL @ 800-543-6055 48 FORTY-EIGHT (48) HOURS PRIOR TO ANY CONSTRUCTION.
4. ALL PROPOSED FACILITIES SHALL MAINTAIN 12" CLEARANCE FROM ALL PUBLIC AND PRIVATE UTILITIES.

PROPOSED FACILITIES

1. THE LOCATIONS OF ALL PROPOSED FACILITIES ARE SHOWN IN AN APPROXIMATE WAY ONLY. THE CONTRACTOR SHALL DETERMINE THE EXACT LOCATION BEFORE COMMENCING WORK. CONTRACTOR AGREES TO BE FULLY RESPONSIBLE FOR ANY AND ALL DAMAGES WHICH MIGHT BE OCCASIONED BY FAILURE TO EXACTLY LOCATE AND PRESERVE ALL UNDERGROUND UTILITIES.
2. THE CONTRACTOR SHALL CALL AEP TEXAS @ 800-344-8377 A MINIMUM OF 48 HOURS PRIOR TO CONSTRUCTION TO HAVE UNDERGROUND LINES FIELD LOCATED.
3. WHEN EXCAVATING WITHIN EIGHTEEN (18") OF THE INDICATED LOCATION OF EXISTING FACILITIES, ALL EXCAVATIONS MUST BE ACCOMPLISHED USING NON-MECHANIZED EXCAVATION PROCEDURES. WHEN BORING, THE CONTRACTOR SHALL EXPOSE THE EXISTING FACILITIES.
4. WHEN THE EXISTING FACILITIES ARE EXPOSED, THE CONTRACTOR WILL PROVIDE SUPPORT TO PREVENT DAMAGE TO THE CONDUIT DUCTS OR CABLES. WHEN EXCAVATING NEAR TELEPHONE POLES, THE CONTRACTOR SHALL BRACE THE POLE FOR SUPPORT.
5. THE PRESENCE OR ABSENCE OF EXISTING FACILITIES SHOWN ON THESE PLANS DOES NOT MEAN THAT THERE ARE NO DIRECT BURIED CABLES OR OTHER CABLES IN CONDUIT IN THE AREA.
6. CONTRACTOR TO CONTACT UTILITY OWNER DEPARTMENT FOR DAMAGE PREVENTION IF THERE ARE ANY QUESTIONS ABOUT BORING OR EXCAVATING NEAR EXISTING FACILITIES.

!!WARNING!! OVERHEAD ELECTRIC

OVERHEAD LINES MAY EXIST ON THE PROPERTY. WE HAVE NOT ATTEMPTED TO MARK THOSE LINES SINCE THEY ARE CLEARLY VISIBLE, BUT THE CONTRACTOR SHOULD LOCATE THEM PRIOR TO BEGINNING ANY CONSTRUCTION. TEXAS LAW, SECTION 753, HEALTH & SAFETY CODE, FORBIDS ALL ACTIVITIES IN WHICH PERSONS OR THINGS MAY COME WITHIN SIX (6) FEET OF LIVE OVERHEAD HIGH-VOLTAGE LINES. PARTIES RESPONSIBLE FOR THE WORK, INCLUDING CONTRACTORS, ARE LEGALLY RESPONSIBLE FOR THE SAFETY OF CONSTRUCTION WORKERS UNDER THIS LAW. THIS LAW CARRIES BOTH CRIMINAL AND CIVIL LIABILITY TO ATTEMPT TO TURN OFF OR REMOVED CALL CENTERPOINT ENERGY @ 713-207-2222.

::CAUTION:: UNDERGROUND GAS

LOCATIONS OF CENTERPOINT ENERGY MAIN LINES (TO INCLUDE CENTERPOINT ENERGY, INTERSTATE PIPELINE LLC WHERE APPLICABLE) ARE SHOWN IN APPROXIMATE LOCATION ONLY. SERVICES LINES ARE NOT USUALLY SHOWN. OUR SIGNATURE ON THESE PLANS ONLY INDICATES THAT OUR FACILITIES ARE SHOWN IN APPROXIMATE LOCATION. IT DOES NOT IMPLY THAT A CONFLICT ANALYSIS HAS BEEN MADE. THE CONTRACTOR SHALL CONTACT THE UTILITY COORDINATING COMMITTEE @ 713-223-4567 OR 800-468-3044 A MINIMUM OF 48 HOURS PRIOR TO CONSTRUCTION TO HAVE MAIN AND SERVICE LINES FIELD LOCATED.

- WHEN CENTERPOINT ENERGY PIPE LINE MARKING ARE NOT VISIBLE, CALL 713-967-8037 (7:00 AM TO 4:30 PM) FOR STATUS OF LINE LOCATION REQUEST BEFORE EXCAVATION BEGINS.
- WHEN EXCAVATING WITHIN (18") OF INDICATED LOCATION OF CENTERPOINT ENERGY FACILITIES, ALL EXCAVATION MUST BE ACCOMPLISHED USING NON-MECHANIZED EXCAVATION PROCEDURES.
- WHEN CENTERPOINT ENERGY FACILITIES ARE EXPOSED, SUFFICIENT SUPPORT MUST BE PROVIDED TO THE FACILITIES TO PREVENT EXCESSIVE STRESS ON THE PIPING.

THE CONTRACTOR IS FULLY RESPONSIBLE FOR ANY DAMAGES CAUSED BY FAILURE TO EXACTLY LOCATE AND PRESERVE THESE UNDERGROUND FACILITIES.

1					
2					
3					
4					
5					
6					
7					
8					
9					
10					
11					
12					
13					
14					
15					
16					
17					
18					
19					
20					
21					
22					
23					
24					
25					
26					
27					
28					
29					
30					
31					
32					
33					
34					
35					
36					
37					
38					
39					
40					
41					
42					
43					
44					
45					
46					
47					
48					
49					
50					
51					
52					
53					
54					
55					
56					
57					
58					
59					
60					
61					
62					
63					
64					
65					
66					
67					
68					
69					
70					
71					
72					
73					
74					
75					
76					
77					
78					
79					
80					
81					
82					
83					
84					
85					
86					
87					
88					
89					
90					
91					
92					
93					
94					
95					
96					
97					
98					
99					
100					

Level 3
ENGINEERING
 LEVEL 3 ENGINEER
 MATH HALL
 ENGINEERING FIRM
 2200 SOUTH FIELD SERVICE
 PROJECT NUMBER
 LOCATION: 1401 WESTPARK
 EXTENSION - HOUSTON, TX
 77057-1200

INDEX SHEET

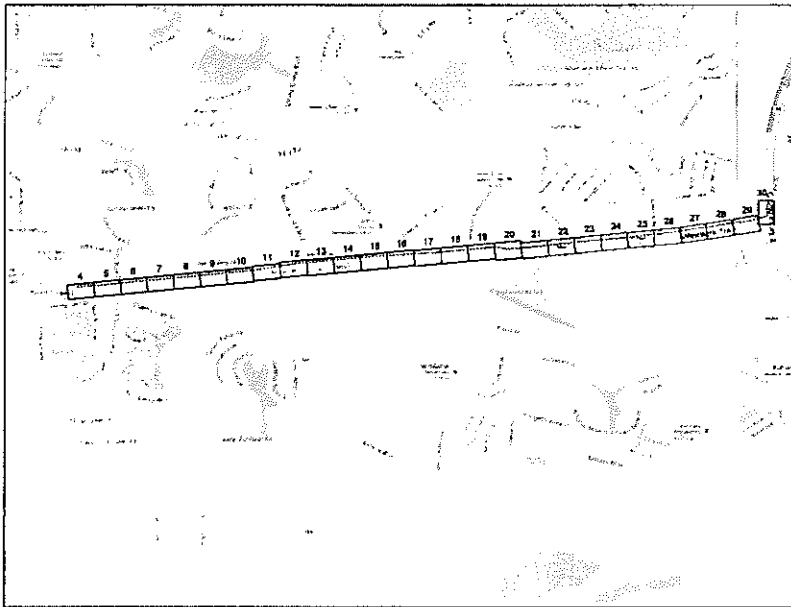

1		
2		
3		
4		
5		
6		
7		
8		
9		
10		
11		
12		
13		
14		
15		
16		
17		
18		
19		
20		
21		
22		
23		
24		
25		
26		
27		
28		
29		
30		

NO.	DATE	BY	CHKD BY
1	11-13-18	AM/SLK	
2	11-13-18	AM/SLK	
3	11-13-18	AM/SLK	
4	11-13-18	AM/SLK	

Level(3)	
CORPORATION	
LEVEL 3 ENGINEER	
REGISTERED	
ENGINEER/PAVING	
GOLDEN FIELD SERVICES	
PROJECT NUMBER:	
LOCATION: 1 W 1005 WEA FHWY	
EXTENSION - HOUSTON, TX	
DATE: 11/13/18	
SHEET 3 OF 31	
CONFIDENTIAL/PROPRIETARY	

HOUSTON, TX
FORT BEND COUNTY



- CONSTRUCTION NOTES**
- 1. EXISTING UNDER-LEVELS
CONDUIT LENGTH EST.
CABLE 100' ±
CONDUIT SIZE 1"
NOTES: VERIFY THE DEPT.
NOTES: VERIFY 1'-2" DEPT.
 - 2. EXIST. HANDBOLE - 2
EX. 100' 1-1/4" W. D. IN
 - 3. CABLE FROM 144F
CABLE UNDER LEVELS
CABLE LENGTH 300'
 - 4. CABLE FROM 144F
CABLE UNDER LEVELS
CABLE LENGTH 300'
 - 5. EXISTING HANDBOLE - 2
 - 6. EXISTING HANDBOLE - 2

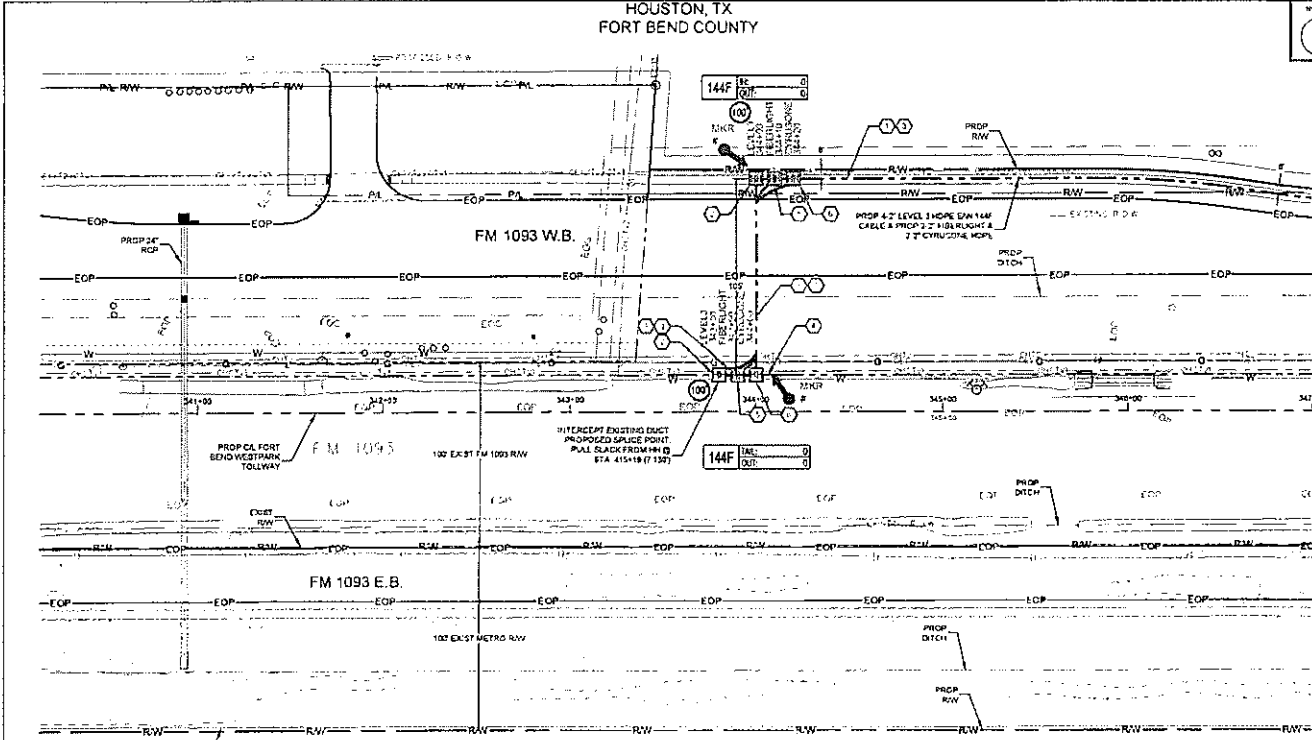

SEE SHEET 5 TO MATCH SURVEY STA. 347+00

- CONSTRUCTION NOTES**
- 1. CONSTRUCTION SHALL SUPPLY ALL HOPE CONDUITS AS NOTED BELOW
 - 2. HOPE CONFIGURATION
 - 3. 2" HOPE
 - 4. 2" HOPE
 - 5. BLACK W/ PURPLE STRIPE
 - 6. BLACK W/ ORANGE STRIPE
 - 7. BLACK W/ GREEN STRIPE
 - 8. BLACK W/ BROWN STRIPE
 - 9. 2" FIBERGLASS
 - 10. BLACK W/ RED STRIPE
 - 11. BLACK W/ BLUE STRIPE
 - 12. 2" FIBERGLASS
 - 13. BLACK W/ WHITE STRIPE
 - 14. BLACK W/ GREY STRIPE

Page Name: OI - Materials			
Unit Code & Description	Units	Estimated Quantity	Actual Quantity
MAT-90110 - CONDUIT 4" HOPE 100' ±	FT	415	
MAT-90270 - TIER 15 33"x48"x36" - WITH KNOCK-OUTS AND RACKING - E-ALL LOADING COVER	EA	6	
MAT-92090 - WARNING TAGS & MJOR MARKERS	EA	2	

Page Name: OI - Work Performance			
Unit Code & Description	Units	Estimated Quantity	Actual Quantity
UOB-30020-S - TRENCH GREATER THAN 1500' TRENCH 48" MINIMUM COVER	FT	405	
UOB-30140-S - PLACE 1" HOPE CONDUITS IN OPEN TRENCH UP TO 2"	FT	405	
UGD-30260-S - PLACE UP TO 216 COUNT FOC IN CONDUIT UP TO 1500' (200' BY COL)	EA	635	
UGD-31270-S - PLACE NEW 33"x48"x36" - NON-CONCRETE HANDBOLE	EA	6	
UGD-31350-S - REMOVE AND DISPOSE OF 1-144F CABLE	FT	300	
UGD-30200-S - INTERCEPT CONDUIT W/ CAST 2"	EA	1	
US3-31790-S - PLACE LOCATE MARKER POST	EA	2	
UOB-30150-S - PLACE ADDITIONAL HOPE IN OPEN TRENCH CONDUIT UP TO 2"	FT	2,835	

UNDERGROUND UTILITIES HAVE BEEN PLOTTED FROM AVAILABLE RECORDS AND FIELD OBSERVATION BUT ARE NOT NECESSARILY EXACT. IT IS THE CONTRACTOR'S RESPONSIBILITY TO FIELD LOCATE ALL UNDERGROUND OBSTRUCTIONS AND UTILITIES PRIOR TO CONSTRUCTION. COMPLETE REPAIR OF ANY AND ALL DAMAGES INCURRED SHALL BE AT THE EXPENSE OF THE CONTRACTOR.



CALL BEFORE YOU DIG
1-800-345-6889
48 HOURS NOTICE REQUIRED

Level(3)
LEVEL ENGINEER
KERNALL
ENGINEERING FIRM
COURTNEY FIELD SERVICES
PROJECT MANAGER
LOCATION: FM 1093 WESTPARK
EXTENSION HOUSTON TX
DAVINGTOWN

SCALE: HOR 1"=50'
SHEET 4 OF 31
CONFIDENTIAL/PROPRIETARY

HOUSTON, TX
FORT BEND COUNTY



CONSTRUCTION NOTES

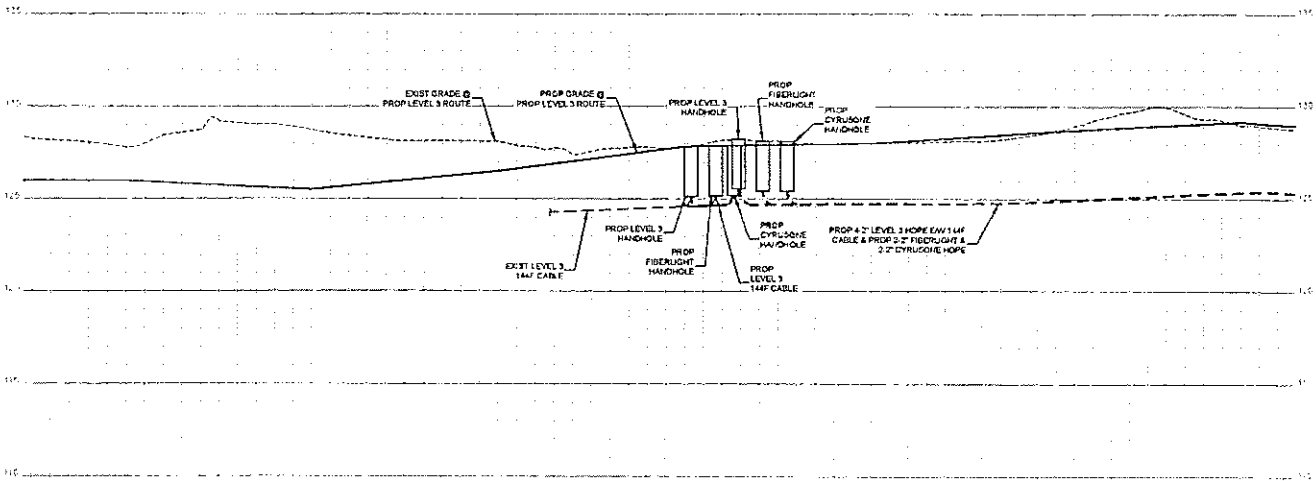

CONTRACTOR NOTE:
CONTRACTOR MUST SUPPLY
ALL HOPE CONDUITS AS
NOTED BELOW

6\"/>

1		
2		
3		
NO	DATE	ENG DESIGN
2-2-13		AL-BRIE
11-13-13		RYSON #1
		ORINA
		DOBNEY

Level(3)
ENGINEERS

LEVEL 3 ENGINEER
KEITH HALL
ENGINEERING FIRM
GOLDEN FIELD SERVICES
PROJECT NUMBER
LOCATION: FIBER OPTIC STRIPING
CATCHCREEK-HOUSTON TX
DRAWING DATE

SCALE: VERT: 1"=5'
SHEET: 4A OF 31
CONFIDENTIAL/PROPRIETARY



CALL 813 ONE YOU DIG
1-800-548-4800
48-HOURS NOTICE REQUIRED

UNDERGROUND UTILITIES HAVE BEEN PLOTTED FROM AVAILABLE RECORDS AND FIELD OBSERVATIONS BUT ARE NOT NECESSARILY EXACT. IT IS THE CONTRACTOR'S RESPONSIBILITY TO FIELD LOCATE ALL UNDERGROUND OBSTRUCTIONS AND UTILITIES PRIOR TO CONSTRUCTION. COMPLETE REPAIR OF ANY AND ALL DAMAGES INCURRED SHALL BE AT THE EXPENSE OF THE CONTRACTOR.

HOUSTON, TX
FORT BEND COUNTY



CONSTRUCTION NOTES

- 1) CONDUIT OWNER LEVELS
CONDUIT LOCATIONS SHOWN
CONDUIT SIZE & TYPE
CONDUIT TYPE: 8" HDPE
NOTE: REMOVE 8"-2" HDPE
- 2) CABLE PROPS: 144"
CABLE OWNER LEVELS
CABLE LOCATIONS SHOWN
NOTE: REMOVE 144" CABLE
- 3) CABLE PROPS: 144"
CABLE OWNER LEVELS
CABLE LOCATIONS SHOWN
NOTE: REMOVE 144" CABLE

SEE SHEET 4 TO MATCH SURVEY STA. 347+00

SEE SHEET 6 TO MATCH SURVEY STA. 353+00

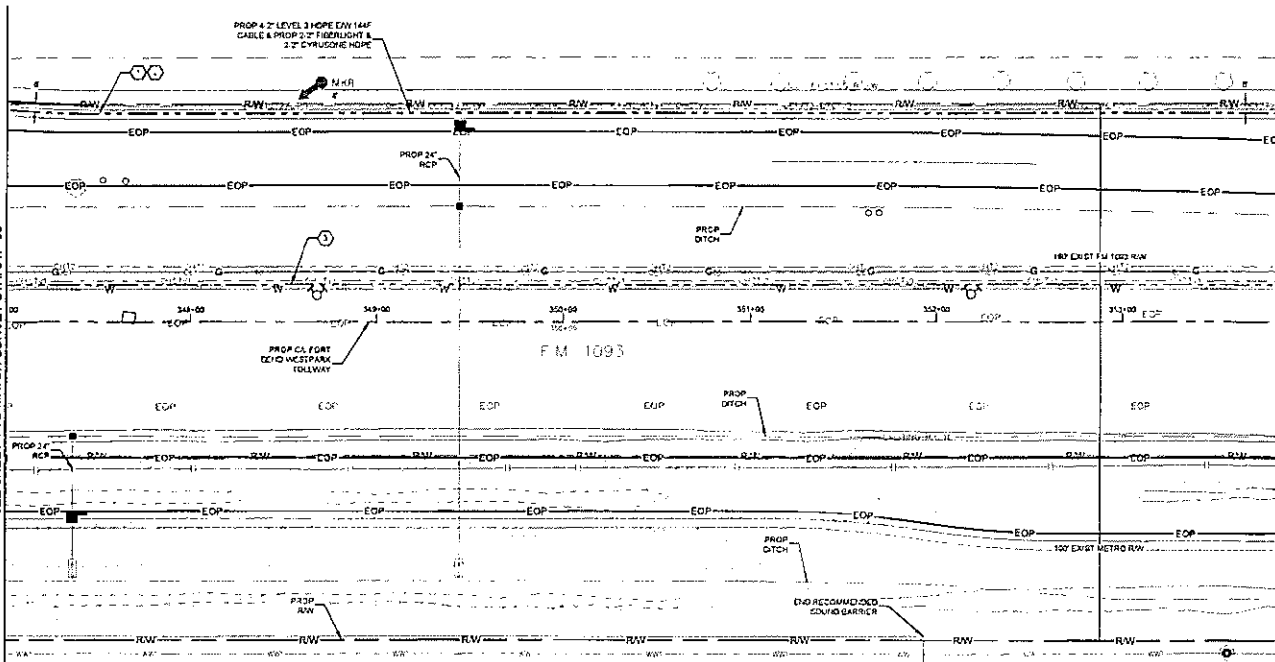

Page Rate Of - Maximum			
Unit Code & Description	Units	Estimated Quantity	Actual Quantity
WAT-00150 - CONDUIT 8" 2" HDPE SDH 8	FT	650	
WAT-02000 - WARNING TAGS AND/OR MARKERS	EA	1	

Page Rate Of - Work Performed			
Unit Code & Description	Units	Estimated Quantity	Actual Quantity
UCB-30050 - TRENCH GREATER THAN 1500' TRENCH 48" MINIMUM COVER	FT	650	
UCB-30140 - PLACE 1" HOPE CONDUITS IN OPEN TRENCH UP TO 2"	FT	650	
UCB-30200 - PLACE UP TO 255 CONDUIT FOC IN CONDUIT UP TO 1500'	FT	650	
UCB-31000 - REMOVE AND DISPOSE OF 1-144" CABLE	FT	650	
UCB-31500 - PLACE LOCATE MARKER POST	EA	1	
UCB-33150 - PLACE ADDITIONAL HOPE IN OPEN TRENCH CONDUIT UP TO 2"	FT	470	

UNDERGROUND UTILITIES HAVE BEEN PLOTTED FROM AVAILABLE RECORDS AND FIELD OBSERVATIONS BUT ARE NOT NECESSARILY EXACT. IT IS THE CONTRACTOR'S RESPONSIBILITY TO FIELD LOCATE ALL UNDERGROUND OBSTRUCTIONS AND UTILITIES PRIOR TO CONSTRUCTION. COMPLETE REPAIR OF ANY AND ALL DAMAGES INCURRED SHALL BE AT THE EXPENSE OF THE CONTRACTOR.



CALL BEFORE YOU DIG
1-800-545-8005
48 HOURS NOTICE REQUIRED

CONTRACTOR NOTE
CONTRACTOR MUST SUPPLY
ALL HOPE CONDUITS AS
NOTED BELOW

- 8" HDPE CONFIGURATION
- 4" (LEVEL 2)
- BLACK W/ PURPLE STRIPE
- BLACK W/ ORANGE STRIPE
- BLACK W/ GREEN STRIPE
- BLACK W/ BROWN STRIPE
- 2" FIRE RESISTANT
- BLACK W/ RED STRIPE
- BLACK W/ BLUE STRIPE
- 2" CYRUSOLITE
- BLACK W/ WHITE STRIPE
- BLACK W/ GREY STRIPE

NO.	DATE	REV. REASON
1		AS-BUILT
2	11-13-18	REVISED E.I.
3	11-13-19	ORIGINAL
4		CURRENT

Level (3)
LEVEL ENGINEER
REGISTERED PROFESSIONAL ENGINEER
GOLDEN FIELDS ENGINEERS
PROJECT NUMBER
LOCATION: FM 1093 WESTPARK
EXTENSION HOUSTON, TX
DATE: 11/13/19

SCALE: HORIZ. 1"=50'
SHEET 5 OF 31
CONTRACT NUMBER: 1919000000000000

HOUSTON, TX
FORT BEND COUNTY



CONSTRUCTION NOTES

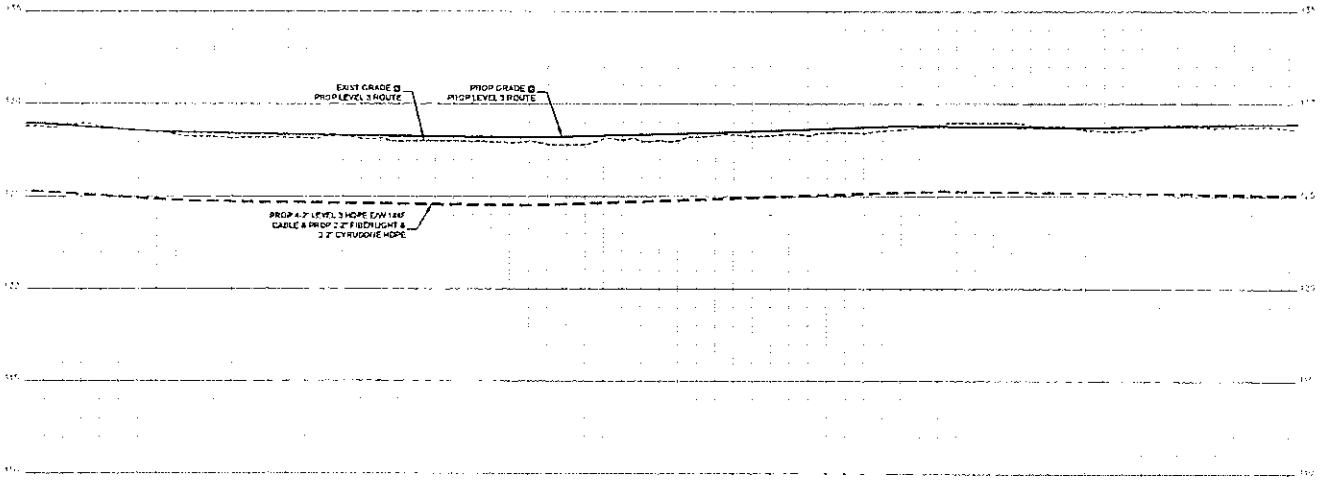

- CONSTRUCTION NOTE
CONTRACTOR MUST SUPPLY
ALL HOPE CONFIGS AS
NOTED BELOW
- 6\"/>

NO	DATE	ENG DESIGN
1		
2		
3		
4		

Level(3)
ENGINEERING

LEVEL ENGINEER
R. STEINMILLER
ENGINEER/REGISTERED FIRM
COURTESY FIELD SERVICES

PROJECT NUMBER
LOCATION: FORT BEND COUNTY
EXTENSION: HOUSTON, TX

DATE/TIME: 11-13-15
CONTRACT: ORIGINAL

SCALE: VERT. 1"=2'
SHEET: SA OF 31
COORDINATE: 110507.14

UNRECORDED UTILITIES HAVE BEEN PLOTTED FROM AVAILABLE RECORDS AND FIELD OBSERVATIONS BUT ARE NOT NECESSARILY EXACT. IT IS THE CONTRACTOR'S RESPONSIBILITY TO FIELD LOCATE ALL UNDERGROUND OBSTRUCTIONS AND UTILITIES PRIOR TO CONSTRUCTION. COMPLETE REPAIR OF ANY AND ALL DAMAGES INCURRED SHALL BE AT THE EXPENSE OF THE CONTRACTOR.



CALL BEFORE YOU DIG
1-800-4-A-DIG
48 HOURS NOTICE REQUIRED

HOUSTON, TX
FORT BEND COUNTY



CONSTRUCTION NOTES

- 1 CONDUIT OWNER LEVELS
CONDUIT LENGTH 240'
CONDUIT CITY: B
CONDUIT SIZE: 2"
CONDUIT TYPE: HDPE
NOTE: BRUSH 8-2" HDPE
- 2 PROPOSED BORE
1 CONDUIT OWNER LEVELS
CONDUIT LENGTH: 400'
CONDUIT CITY: B
CONDUIT SIZE: 2"
CONDUIT TYPE: HDPE
NOTE: BRUSH 8-2" HDPE
- 3 CABLE OWNER LEVELS
CABLE LENGTH: 144'
- 4 CABLE OWNER LEVELS
CABLE LENGTH: 630'
NOTE: ABOVE 144' CABLE

CONTRACTOR NOTE
CONTRACTOR MUST SUPPLY
ALL HOPE CONDUITS AS
NOTED BELOW

- 4.7 HOPE CONFIGURATION
12" LEVEL (EOL)
- BLACK W/ PURPLE STRIPE
 - BLACK W/ ORANGE STRIPE
 - BLACK W/ GREEN STRIPE
 - BLACK W/ BROWN STRIPE
 - 2" FIBERGLASS
 - BLACK W/ RED STRIPE
 - BLACK W/ BLUE STRIPE
 - 2" CYRUSOLIC
 - BLACK W/ WHITE STRIPE
 - BLACK W/ GREY STRIPE

NO.	DATE	END DESIGN
1		
2		

DATE	REVISION	BY
11-13-15	ORIGINAL	

Level (3)

LEVEL BENCHER
KEITH HALL
ENGINEER-IN-CHARGE
ROCKY FELD SERVICES
PROJECT NUMBER
LOCATION: FM 1093 @ SPARK
EXTENSION, HOUSTON, TX
DATE: 11/13/15

SCALE: HORIZ 1"=10'
VERTICAL 1"=10'
SHEET 6 OF 31
CONTRACT NUMBER: 1447

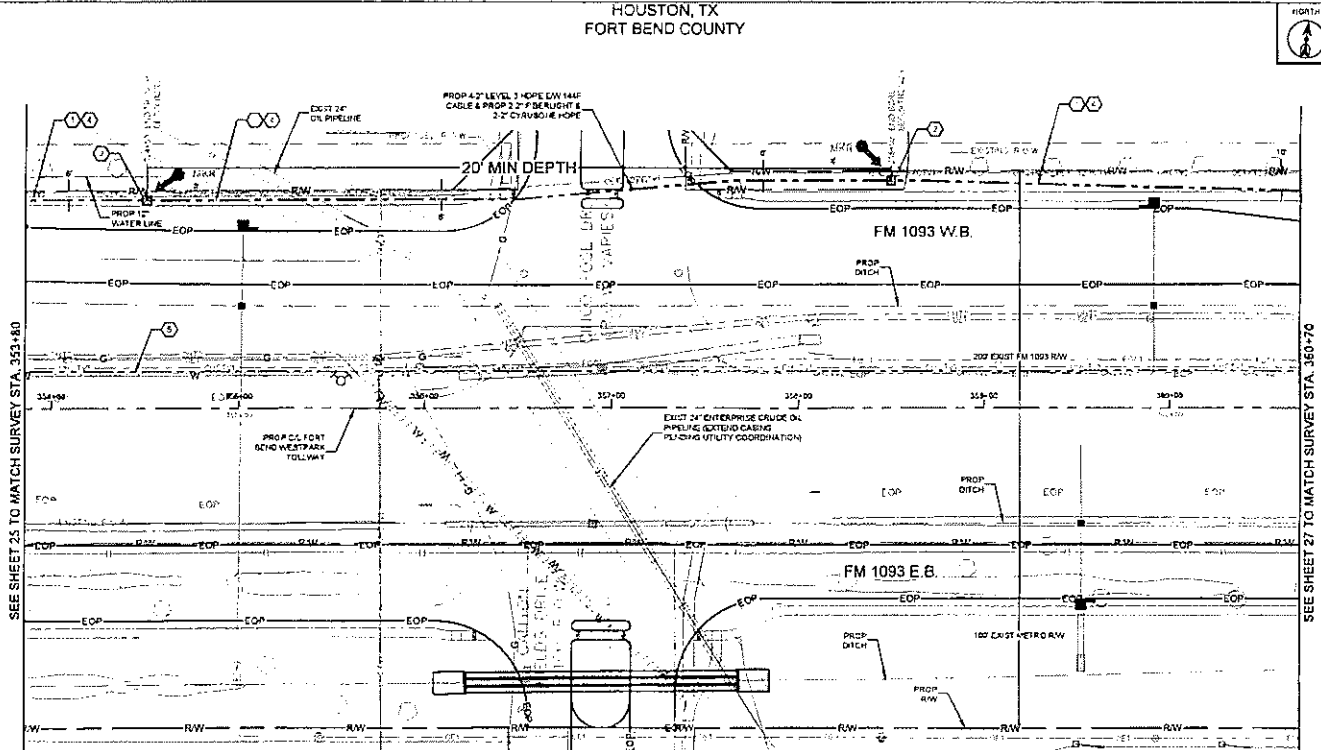

SEE SHEET 25 TO MATCH SURVEY STA. 353+40

SEE SHEET 27 TO MATCH SURVEY STA. 360+70

Propose Item Off - Materials			
U-M Code & Description	Units	Estimate Quantity	Actual Quantity
MAT-2015D - CONDUIT 8-2" HDPE SDR 11	FT	630	
MAT-2020D - VARIETAS TAGS AND/OR MARKERS	EA	2	

Propose Item Off - Work Performed			
U-M Code & Description	Units	Estimate Quantity	Actual Quantity
UGB-2005D-S - TRENCH GREATER THAN 1800' TRENCH 48" W/ 1/4" ULM COVER	FT	200	
UGB-2014D-S - PLACE 1 - HOPE CONDUITS IN OPEN TRENCH UP TO 2'	FT	200	
UGB-2020D-S - DIRECTIONAL BORE GREATER THAN 1500' 1 HOPE CONDUIT UP TO 2'	FT	400	
UGB-2025D-S - PLACE UP TO 255 COUNT FOC IN CONDUIT UP TO 1500'	FT	630	
UGD-3114C-S - EXCAVATE SMALL HPY 6'X4'X3'	EA	2	
UGD-3105D-S - REMOVE AND DISPOSE OF 1-1/4" GASLET	FT	622	
UGD-3119D-S - PLACE LOCATE MARKER POST	EA	2	
UGB-3015D-S - PLACE ADDITIONAL HOPE IN OPEN TRENCH CONDUIT UP TO 2'	FT	2,050	
UGD-3070D-S - DIR BORE GREATER THAN 1500' ADDITIONAL CONDUIT UP TO 2'	FT	2,820	

UNDERGROUND UTILITIES HAVE BEEN PLOTTED FROM AVAILABLE RECORDS AND FIELD OBSERVATIONS BUT ARE NOT NECESSARILY EXACT. IT IS THE CONTRACTOR'S RESPONSIBILITY TO FIELD LOCATE ALL UNDERGROUND OBSTRUCTIONS AND UTILITIES PRIOR TO CONSTRUCTION. COMPLETE REPAIR OF ANY AND ALL DAMAGES INCURRED SHALL BE AT THE EXPENSE OF THE CONTRACTOR.

CALL BEFORE YOU DIG
800-545-6005
48 HOURS NOTICE REQUIRED

HOUSTON, TX
FORT BEND COUNTY



CONSTRUCTION NOTES

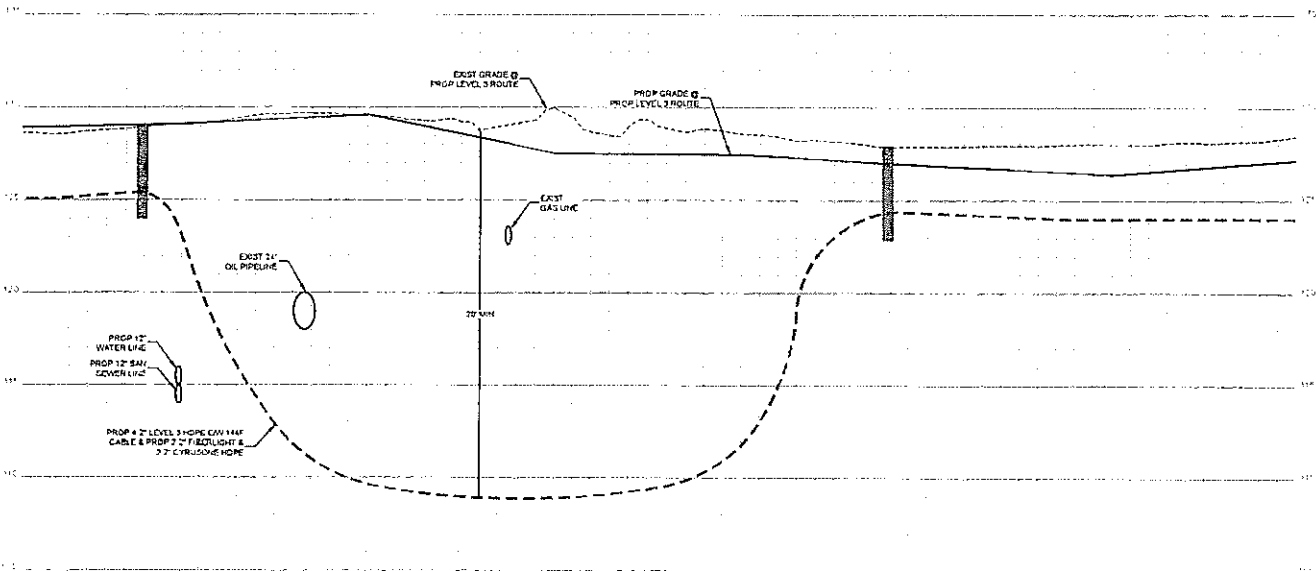

- CONTRACTOR NOTE
CONTRACTOR MUST SUPPLY
ALL HOPE CONFIGS AS
NOTED BELOW
- 4" LEVELID
- BLACK W/ PURPLE STRIPE
 - BLACK W/ ORANGE STRIPE
 - BLACK W/ GREEN STRIPE
 - BLACK W/ BROWN STRIPE
- 2" FIBERLIGHT
- BLACK W/ RED STRIPE
 - BLACK W/ BLUE STRIPE
- 2" CYRUSKLE
- BLACK W/ WHITE STRIPE
 - BLACK W/ GREY STRIPE

1		
2		
3		
NO	DATE	END DESIGN
1		AS-BUILT
2	11-12-18	REVISED
3	11-12-18	ORANGE
4		ORANGE

Level(3)
LEVEL ENGINEERING

LEVEL ENGINEER
KEITH HALL

ENGINE PRODUCTION
QUALITY FIELD SERVICES

PROJECT NUMBER

LOCATION: FM 1033 VICTOR PARK
EAST HOUSTON - HOUSTON, TX

DATE: 11/12/18

SCALE: VERT 1"=4'

SHEET: CA OF 21

FOR CONTRACT REPRESENTATIVE

UNDERGROUND UTILITIES HAVE BEEN PLOTTED FROM AVAILABLE RECORDS AND FIELD OBSERVATIONS BUT ARE NOT NECESSARILY EXACT. IT IS THE CONTRACTOR'S RESPONSIBILITY TO FIELD LOCATE ALL UNDERGROUND OBSTRUCTIONS AND UTILITIES PRIOR TO CONSTRUCTION. COMPLETE REPAIR OF ANY AND ALL DAMAGES INCURRED SHALL BE AT THE EXPENSE OF THE CONTRACTOR.



CALL BEFORE YOU DIG
1-800-547-6225
48 HOURS NOTICE REQUIRED

HOUSTON, TX
FORT BEND COUNTY



CONSTRUCTION NOTES

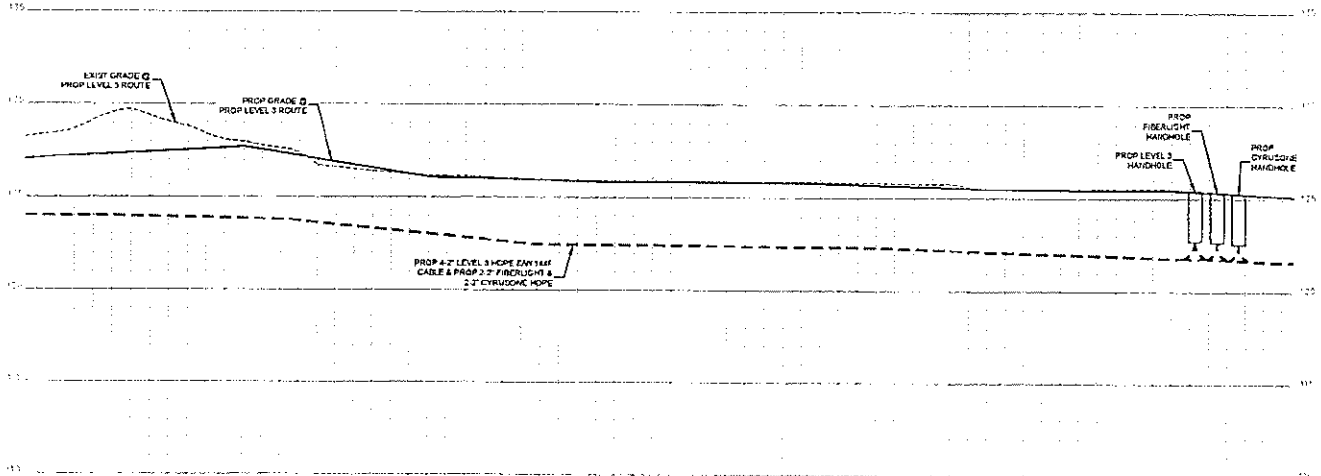

- CONTRACTOR MUST CONTRACTOR MUST SUPPLY ALL HOPE CONDUITS AS NOTED BELOW
- 4-2' HOPE CONFIGURATION
- 4-2' LEVELS
 - BLACK W/ PURPLE STRIPE
 - BLACK W/ ORANGE STRIPE
 - BLACK W/ GREEN STRIPE
 - BLACK W/ BROWN STRIPE
 - 2' FIBERGLASS
 - BLACK W/ RED STRIPE
 - BLACK W/ BLUE STRIPE
 - 2' CYRUSONE
 - BLACK W/ WHITE STRIPE
 - BLACK W/ GREY STRIPE

UNDERGROUND UTILITIES HAVE BEEN PLOTTED FROM AVAILABLE RECORDS AND FIELD OBSERVATIONS BUT ARE NOT NECESSARILY EXACT. IT IS THE CONTRACTOR'S RESPONSIBILITY TO FIELD LOCATE ALL UNDERGROUND OBSTRUCTIONS AND UTILITIES PRIOR TO CONSTRUCTION. COMPLETE REPAIR OF ANY AND ALL DAMAGES INCURRED SHALL BE AT THE EXPENSE OF THE CONTRACTOR.



CALL BEFORE YOU DIG
1-800-543-8000
48 HOUR NOTICE REQUIRED

1		
2		
3	DATE	ENG. DESIGN
4		
5	AS-BUILT	
6	REVISION # 1	
7	ORIGINAL	
8	COMMENT	
Level(3)		
LEVEL 3 DESIGNER		
ENGINEERING FIRM		
GOLDEN FIELD SERVICES		
PROJECT NUMBER		
LOCATION: FM 1233 WESTPARK		
EXTENSION: HOUSTON, TX		
DATE: 10/20/2016		
SCALE	1" = 10'	
SHEET 7A OF 31		
EDMUNDS@GOLDENFIELD.COM		

HOUSTON, TX
FORT BEND COUNTY



CONSTRUCTION NOTES

- 1 CONDUIT OVER LEVELS
CONDUIT LENGTH 145'
CONDUIT SIZE 8"
CONDUIT TYPE HOPE
NOTES: BORE 8-7" HOPE
- 2 PROPOSED BORE??
- 3 CONDUIT OVER LEVELS
CONDUIT LENGTH 245'
CONDUIT SIZE 8"
CONDUIT TYPE HOPE
NOTES: BORE 8-7" HOPE
- 4 CABLE PINS: 144"
CABLE OVER LEVELS
CABLE LENGTH 250'
- 5 CABLE PINS: 144"
CABLE OVER LEVELS
CABLE LENGTH 240'
NOTES: REMOVE 144" CABLE

CONTRACTOR NOTE
CONTRACTOR SHALL SUPPLY
ALL HOPE CONDUITS AS
NOTED BELOW

- 8" HOPE CONFIGURATION:
4" LEVELS
- BLACK W/ PURPLE STRIPE
 - BLACK W/ ORANGE STRIPE
 - BLACK W/ GREEN STRIPE
 - BLACK W/ BROWN STRIPE
 - 2" FIBERGLASS
 - BLACK W/ RED STRIPE
 - BLACK W/ BLUE STRIPE
 - 2" CYRUSIDE
 - BLACK W/ WHITE STRIPE
 - BLACK W/ GREY STRIPE

NO.	DATE	BY	REVISION
1			AS-BUILT
2	11-13-19	DRM/ML	REVISION # 2

Level 3
LEVEL 3 ENERGY SERVICES
11111 RICHMOND AVE
HOUSTON, TX 77036
PHONE: 281-410-1000
WWW.LEVEL3.COM

PROJECT NUMBER: FM 1093 WESTPARK
LOCATION: FM 1093 WESTPARK
DATE: 11/13/19

SCALE: HOR 1"=50'
SHEET: 8 OF 31
CONTRACT: 1919000100

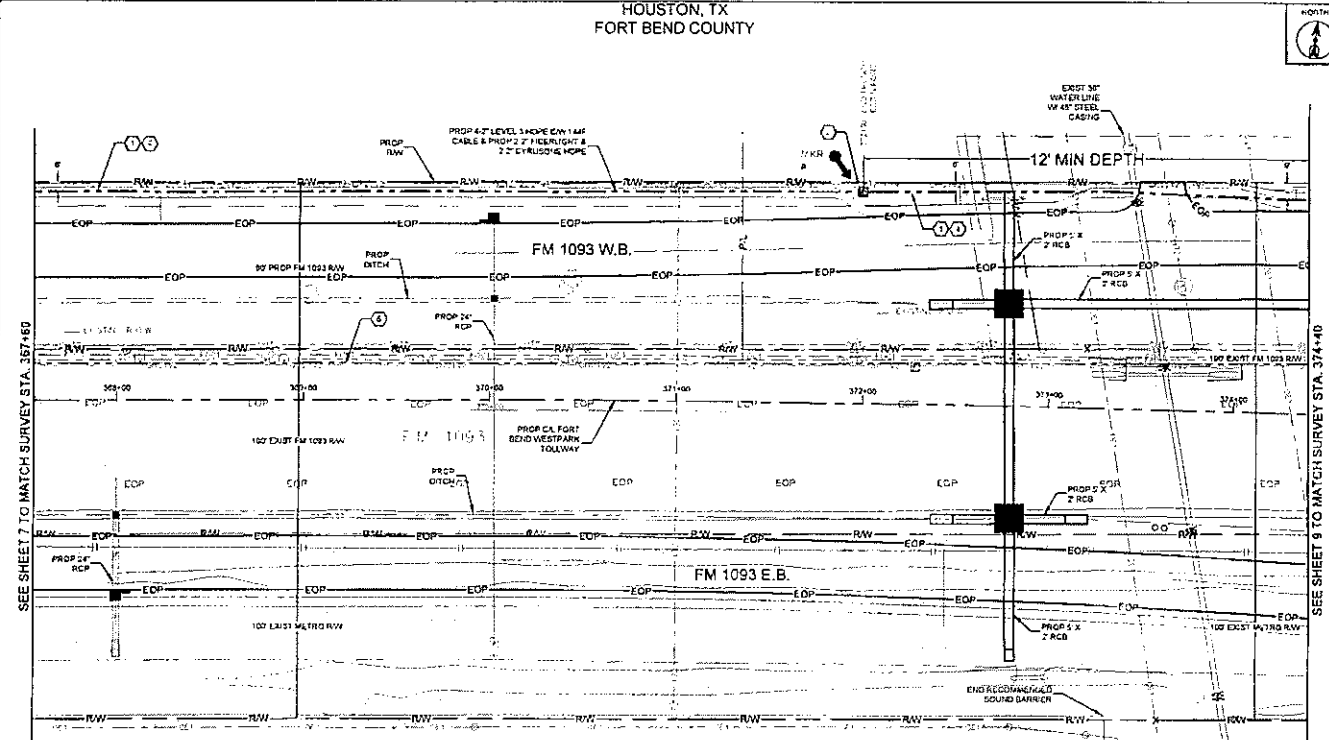

Page Plate C3 - Materials

Unit Code & Description	Units	Quantity	Actual Quantity
MAT-00150 - CONDUIT 8" HOPE SDR 9	FT	680	
MAT-02250 - WARNING TAGS AND/OR MARKERS	EA	1	

Page Plate C3 - Vitrified

Unit Code & Description	Units	Quantity	Actual Quantity
UG3-3005-S - TRENCH GREATER THAN 1500' TRENCH 48" MINIMUM COVER	FT	440	
UG3-3214-S - PLACE 1" HOPE CONDUITS IN OPEN TRENCH UP TO 2"	FT	440	
UG3-3090-S - DRILL ONE BORE GREATER THAN 1500' 1" HOPE CONDUIT UP TO 2"	FT	240	
UG3-3090-S - PLACE UP TO 288 COUNT FOC IN CONDUIT UP TO 1500'	FT	250	
UG3-3164-S - EXCAVATE SMALL PIT 6'X4'X3'	CA	1	
UG3-3100-S - REMOVE AND DISPOSE OF 1-1/4" CABLE	FT	600	
UG3-3190-S - PLACE LOCATE MARKER POST	EA	1	
UG3-3010-S - PLACE ADDITIONAL HOPE IN OPEN TRENCH CONDUIT UP TO 2"	FT	3,050	
UG3-3010-S - DRILL BORE GREATER THAN 1500' ADDITIONAL CONDUIT UP TO 2"	FT	1,680	

UNDERGROUND UTILITIES HAVE BEEN PLOTTED FROM AVAILABLE RECORDS AND FIELD OBSERVATIONS BUT ARE NOT NECESSARILY EXACT. IT IS THE CONTRACTOR'S RESPONSIBILITY TO FIELD LOCATE ALL UNDERGROUND OBSTRUCTIONS AND UTILITIES PRIOR TO CONSTRUCTION. COMPLETE REPAIR OF ANY AND ALL DAMAGES INCURRED SHALL BE AT THE EXPENSE OF THE CONTRACTOR.



HOUSTON, TX
FORT BEND COUNTY



CONSTRUCTION NOTES

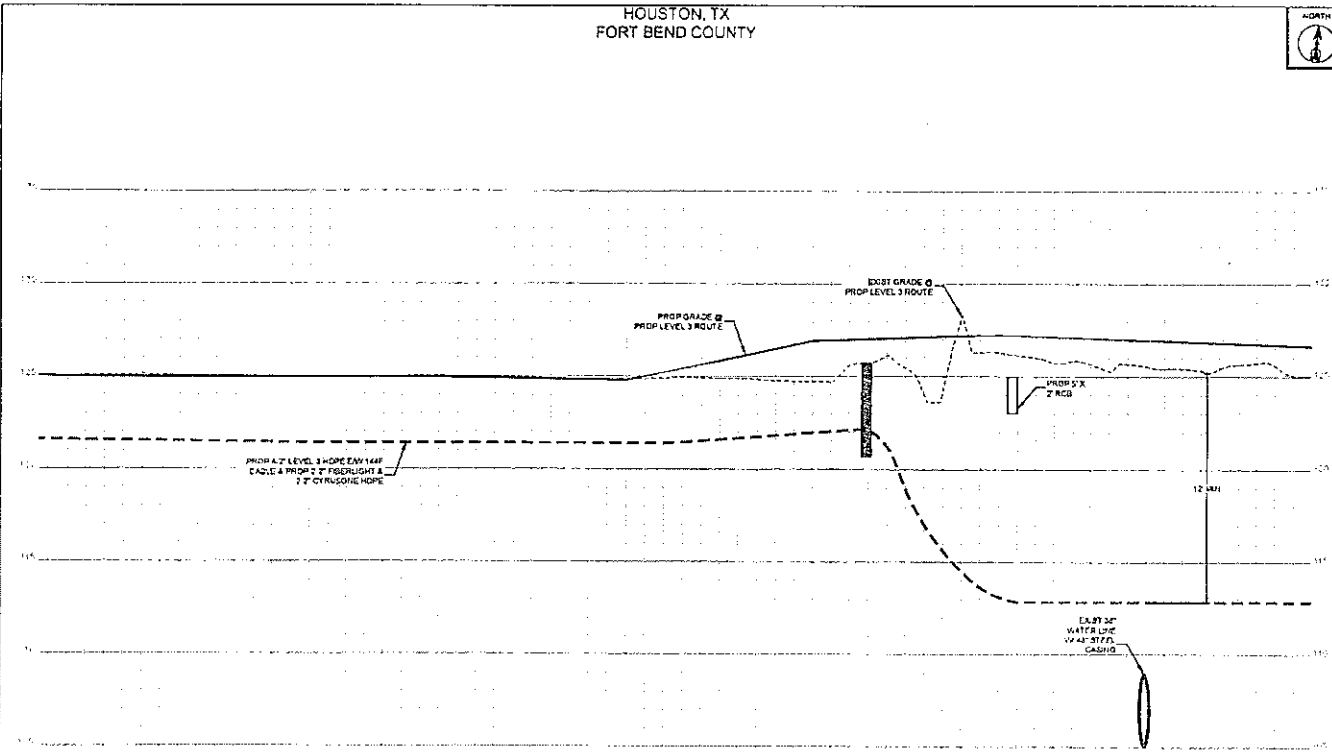

- CONTRACTOR NOTE**
CONTRACTOR MUST SUPPLY ALL HOPE CONDUITS AS NOTED BELOW
- 8\"/>
 - BLACK W/ PURPLE STRIPE
 - BLACK W/ ORANGE STRIPE
 - BLACK W/ GREEN STRIPE
 - BLACK W/ BROWN STRIPE
 - 2\"/>
 - BLACK W/ RED STRIPE
 - BLACK W/ BLUE STRIPE
 - 3\"/>
 - BLACK W/ WHITE STRIPE
 - BLACK W/ GREY STRIPE**

1		
2		
3		
NO.	DATE	END DESIGN
1	7-12-18	DESIGN 2 1
2	11-12-19	OPENING
3		QUANTIFY
4		REWORK

Level 3
ENGINEERS

LEVEL 3 ENGINEER
KEITH HALL
ENGINEERING FIRM
500 DEN FELD SERVICE E
HOUSTON, TX 77056
PROJECT NUMBER
LOCATION: FM 1053 W/ STARK
EXTENSION: HOUSTON, TX
DRAWN BY: JMM

SCALE: VERT 1"=5'
SHEET 8A OF 31
CONTRACT: 1807000000

UNDERGROUND UTILITIES HAVE BEEN PLOTTED FROM AVAILABLE RECORDS AND FIELD OBSERVATIONS BUT ARE NOT NECESSARILY EXACT. IT IS THE CONTRACTOR'S RESPONSIBILITY TO FIELD LOCATE ALL UNDERGROUND OBSTRUCTIONS AND UTILITIES PRIOR TO CONSTRUCTION. COMPLETE REPAIR OF ANY AND ALL DAMAGES INCURRED SHALL BE AT THE EXPENSE OF THE CONTRACTOR.



CALL BEFORE YOU DIG
1-800-543-8225
48 HOURS NOTICE REQUIRED

HOUSTON, TX
FORT BEND COUNTY



CONSTRUCTION NOTES

1. CONDUIT OWNER: LEVEL 3
CONDUIT LENGTH: 144'
CONDUIT SIZE: 4"
CONDUIT TYPE: HDPE
NOTE: BORE 8-2" HOPE
2. PROPOSED BORE
3. CONDUIT OWNER: LEVEL 3
CONDUIT LENGTH: 480'
CONDUIT SIZE: 4"
CONDUIT TYPE: HDPE
NOTE: BORE 8-2" HOPE
4. CABLE NUMBER: 144F
CABLE OWNER: LEVEL 3
CABLE LENGTH: 500'
5. CABLE NUMBER: 144F
CABLE OWNER: LEVEL 3
CABLE LENGTH: 500'
NOTE: BORE 144F CABLE

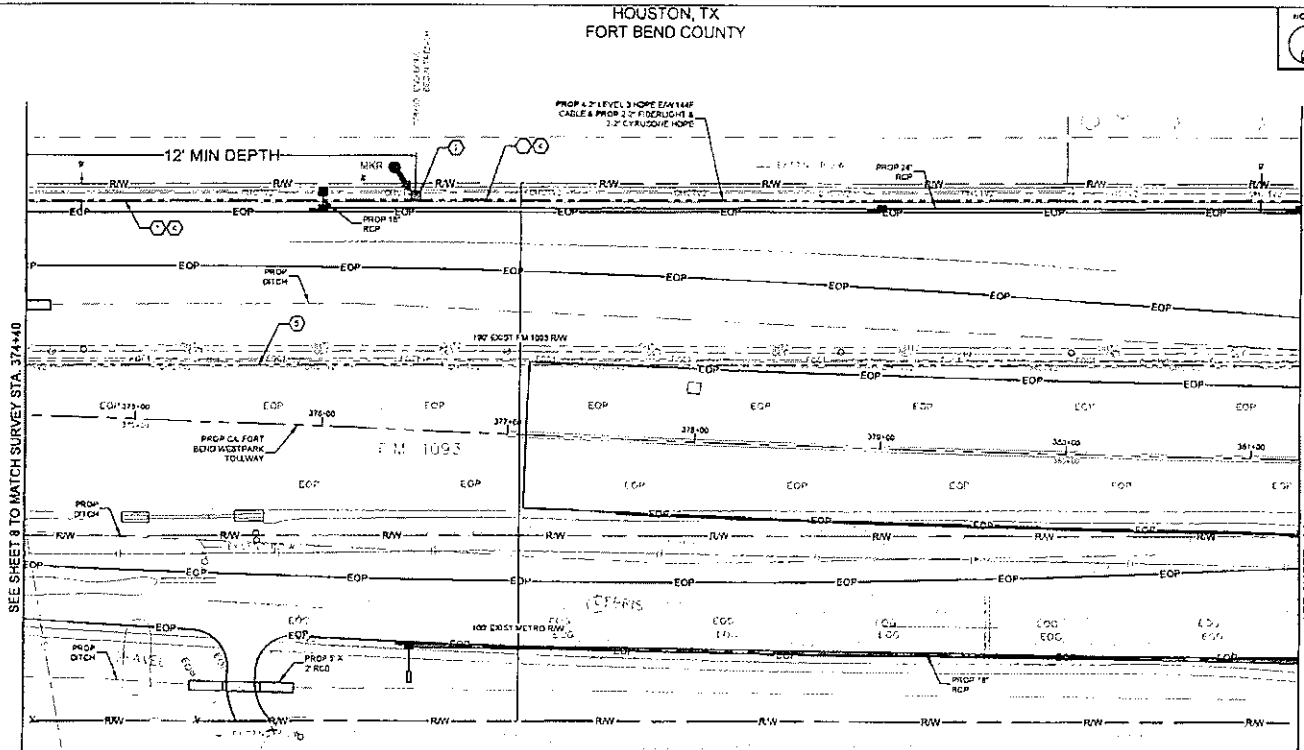

SEE SHEET 8 TO MATCH SURVEY STA. 374+40

SEE SHEET 10 TO MATCH SURVEY STA. 381+30

Stage Make Off - Materials			
Unit Code & Description	Units	Estimated Quantity	Actual Quantity
MAT-08150 - CONDUIT 4-2" HDPE GDR 9	FT	480	
MAT-8200 - WARNING TAGS AND/OR MARKERS	EA	1	

Proposed Work Performed			
Unit Code & Description	Units	Estimated Quantity	Actual Quantity
UGB-30250-S - TRENCH GREATER THAN 1500' TRENCH 48" MINIMUM COVER	FT	480	
UGB-30140-S - PLACE 1" HOPE CONDUITS IN OPEN TRENCH UP TO 2"	FT	450	
UGB-30260-S - DIRECTIONAL BORE GREATER THAN 1500' 3" HOPE CONDUIT UP TO 2"	FT	210	
UGB-30280-S - PLACE UP TO 288 COUNT FOC IN CONDUIT UP TO 1500'	FT	620	
UGB-31640-S - EXCAVATE SMALL PIT 6'x6'x5'	CA	1	
UGB-31050-S - REMOVE AND DISPOSE OF 1 1/4" CABLE	FT	600	
UGB-31060-S - PLACE LOCATE MARKER POST	EA	1	
UGB-30110-S - PLACE ADDITIONAL HOPE IN OPEN TRENCH CONDUIT UP TO 2"	FT	3,300	
UGB-30100-S - D.A. BORE GREATER THAN 1500' ADDITIONAL CONDUIT UP TO 2"	FT	1,470	

UNDERGROUND UTILITIES HAVE BEEN PLOTTED FROM AVAILABLE RECORDS AND FIELD OBSERVATIONS BUT ARE NOT NECESSARILY EXACT. IT IS THE CONTRACTOR'S RESPONSIBILITY TO FIELD LOCATE ALL UNDEGROUND OBSTRUCTIONS AND UTILITIES PRIOR TO CONSTRUCTION. COMPLETE REPAIR OF ANY AND ALL DAMAGES INCURRED SHALL BE AT THE EXPENSE OF THE CONTRACTOR.



CALL BEFORE YOU DIG
1-800-445-6000
48 - HOURS NOTICE REQUIRED

Level(3)
CONSTRUCTION

LEVEL 3 ENGINEER
14111 WALL
DUNWELLS ROAD
GOLDEN VALLEY, TEXAS 75038
PROJECT NUMBER:
LOCATION: 14111 WALL ST PARK
EXTENSION, HOUSTON, TX
77055-0000

SCALE: 1"=20'
SHEET: 9 OF 31
CONTRACT: 14111 WALL

HOUSTON, TX
FORT BEND COUNTY



CONSTRUCTION NOTES

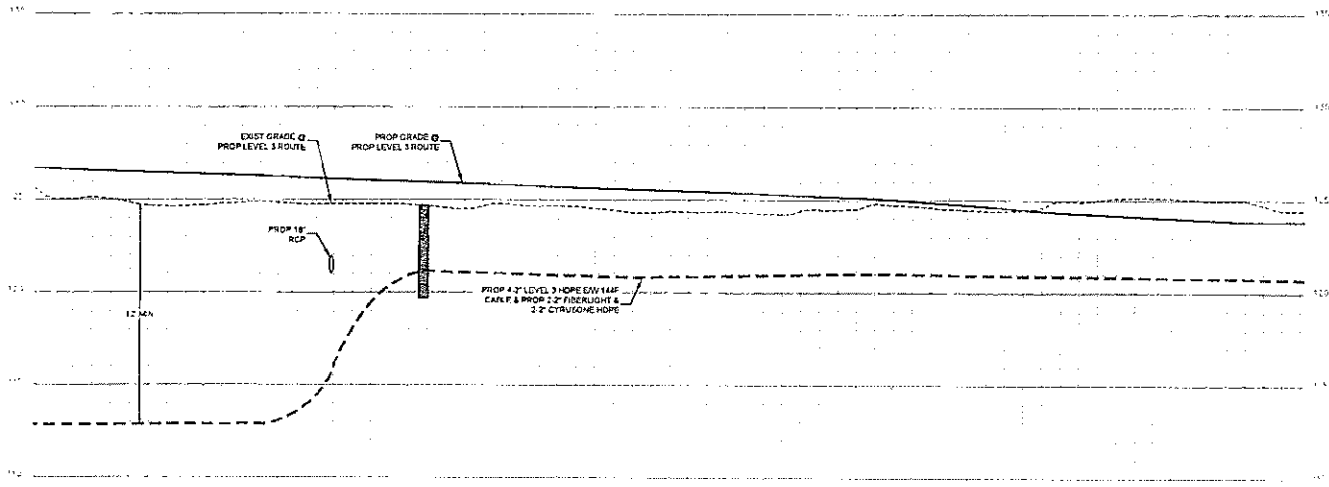

CONTRACTOR NOTE
CONTRACTOR MUST SUPPLY
ALL HOPE COVOLITS AS
NOTED BELOW

- 5" HOPE CONFIGURATION
- 4" LEVELS
 - BLACK W/ PURPLE STRIPE
 - BLACK W/ ORANGE STRIPE
 - BLACK W/ GREEN STRIPE
 - BLACK W/ BROWN STRIPE
 - 2" FIRELIGHT
 - BLACK W/ RED STRIPE
 - BLACK W/ BLUE STRIPE
 - 2" CYRUSONE
 - BLACK W/ WHITE STRIPE
 - BLACK W/ GREY STRIPE

NO	DATE	END DESIGN
1		
2-2-18		AS-BUILT
11-13-15		ORIGINAL
		REVISION

Level(3)
ENGINEERS

LEVEL ENGINEER
KEVIN MCEL
ENGINEERING FIRM
GOLDEN FIELD SERVICES
PROJECT NUMBER
LOCATION: 181195 WESTPARK
EXTENSION, HOUSTON, TX
DRAWING DATE

SCALE: VERT 1"=1'
SHEET: 5A OF 31
© 2018 LEVEL(3) ENGINEERS

UNDERGROUND UTILITIES HAVE BEEN PLOTTED FROM AVAILABLE RECORDS AND FIELD OBSERVATIONS BUT ARE NOT NECESSARILY EXACT. IT IS THE CONTRACTOR'S RESPONSIBILITY TO FIELD LOCATE ALL UNDERGROUND OBSTRUCTIONS AND UTILITIES PRIOR TO CONSTRUCTION. COMPLETE REPAIR OF ANY AND ALL DAMAGES INCURRED SHALL BE AT THE EXPENSE OF THE CONTRACTOR.



CALL BEFORE YOU DIG
1-800-245-6000
48 HOURS NOTICE REQUIRED

HOUSTON, TX
FORT BEND COUNTY

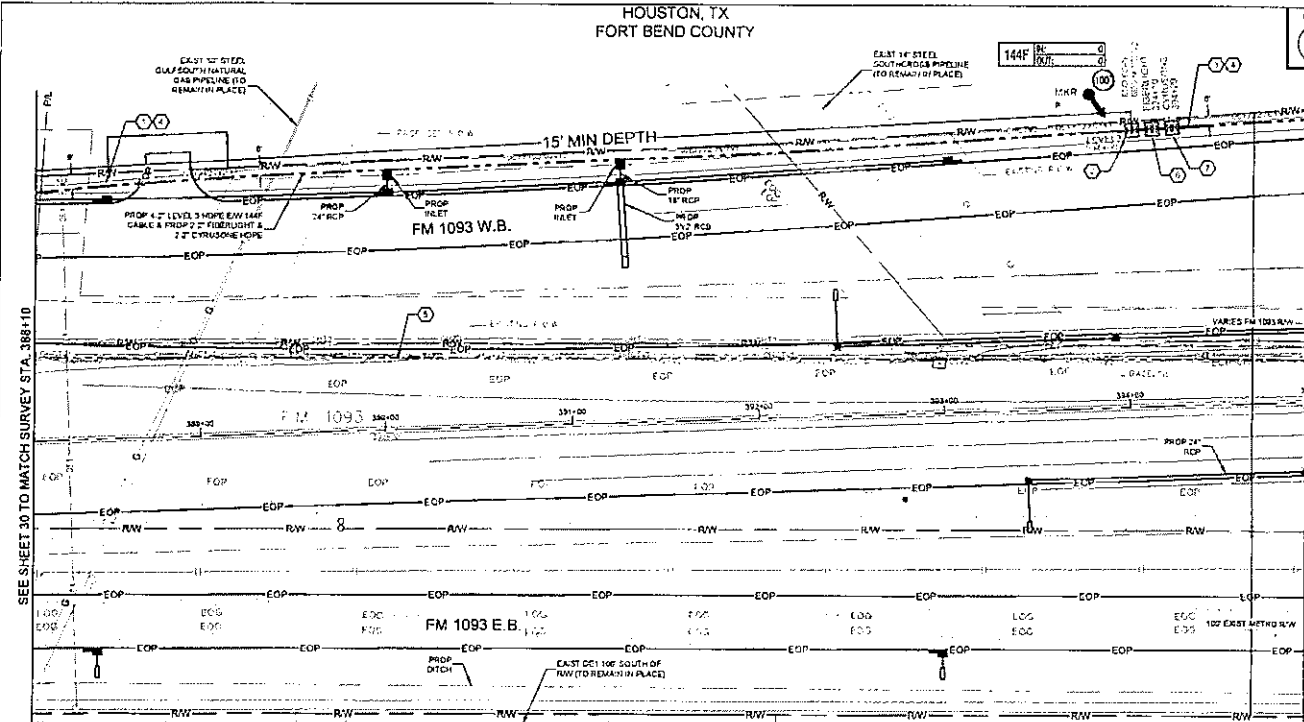

- CONSTRUCTION NOTES**
1. CONDUIT OWNER LEVELS
CONDUIT OWNER 1500'
CONDUIT SIZE 2"
CONDUIT TYPE HDPE
NOTE: SIZE 8-2" HDPE
 2. LEVELS HANGHOLE
CONDUIT OWNER LEVELS
CONDUIT LENGTH 100'
CONDUIT SIZE 2"
CONDUIT TYPE HDPE
NOTE: 3000 PSI 8-2" HDPE
 3. CABLE TIE: 1/4" CABLE OWNER LEVELS
CABLE LENGTH 100'
 4. CABLE TIE: 1/4" CABLE OWNER LEVELS
CABLE LENGTH 100'
NOTE: REMOVE 1/4" CABLE
7/8" DIA. HANG-HOLE
 5. CABLE TIE: 1/4" CABLE OWNER LEVELS
CABLE LENGTH 100'
 6. CYCLONE HANG-HOLE

- CONTRACTOR NOTE**
CONTRACTOR MUST SUPPLY
ALL HDPE CONDUITS AS
NOTED BELOW
- 8-2" HDPE CONFIGURATION
- BLACK W/ PURPLE STRIPE
 - BLACK W/ ORANGE STRIPE
 - BLACK W/ GREEN STRIPE
 - BLACK W/ BROWN STRIPE
 - 2" FIBERGLASS
 - BLACK W/ RED STRIPE
 - BLACK W/ BLUE STRIPE
 - 2" CYCLONE
 - BLACK W/ WHITE STRIPE
 - BLACK W/ GREY STRIPE



UNDERGROUND UTILITIES HAVE BEEN PLOTTED FROM AVAILABLE RECORDS AND FIELD OBSERVATIONS BUT ARE NOT NECESSARILY EXACT. IT IS THE CONTRACTOR'S RESPONSIBILITY TO FIELD LOCATE ALL UNDERGROUND OBSTRUCTIONS AND UTILITIES PRIOR TO CONSTRUCTION. COMPLETE REPAIR OF ANY AND ALL DAMAGES INCURRED SHALL BE AT THE EXPENSE OF THE CONTRACTOR.

Unit Code & Description	Units	Estimated Quantity	Actual Quantity
MAT-80150 - CONDUIT 8-2" HDPE EDR 9	FT	800	
MAT-90970 - TIE 1/4" 307487306 - WITH KNOCK-OUTS AND RACKING - INCLUDING COVER	EA	3	
MAT-91020 - WARNING TAGS AND/OR MARKERS	EA	1	

Unit Code & Description	Units	Estimated Quantity	Actual Quantity
UGB-32023-S - TRENCH GREATER THAN 1500' TRENCH 40" MINIMUM COVER	FT	100	
UGB-32143-R - PLACE 1 - HDPE CONDUITS IN OPEN TRENCH UP TO 2"	FT	100	
UGB-32030-S - DIRECTIAL BORE GREATER THAN 1500' 1 HDPE CONDUIT UP TO 2"	FT	200	
UGB-32020-S - PLACE UP TO 265 COUNT EDR IN CONDUIT UP TO 1500' (100 IN COLL)	FT	750	
UGB-31270-S - PLACE NEW 30"x48"x33" NON-CONCRETE HANGHOLE	EA	3	
UGB-31050-S - REMOVE AND DISPOSE OF 1-1/4" CABLE	FT	200	
UGB-31020-S - PLACE LOCATE MARKER POST	EA	1	
UGB-32110-S - PLACE ADDITIONAL HDPE IN OPEN TRENCH CONDUIT UP TO 2"	FT	700	
UGB-32700-S - EDR BORE GREATER THAN 1500' ADDITIONAL CONDUIT UP TO 2"	FT	4150	

Level 3

LEVEL 3 ENGINEERING
KEITH HALL
ENGINEERING FROM
OUR FIELD SERVICES

PROJECT NUMBER
LOCATION: FM 1093 WESTPARK
EXTENSION HOUSTON, TX
DATE: 03/20/20

SCALE: 1"=50'
SHEET: 11 OF 31
CON: 001/2000000000

HOUSTON, TX
FORT BEND COUNTY



CONSTRUCTION NOTES

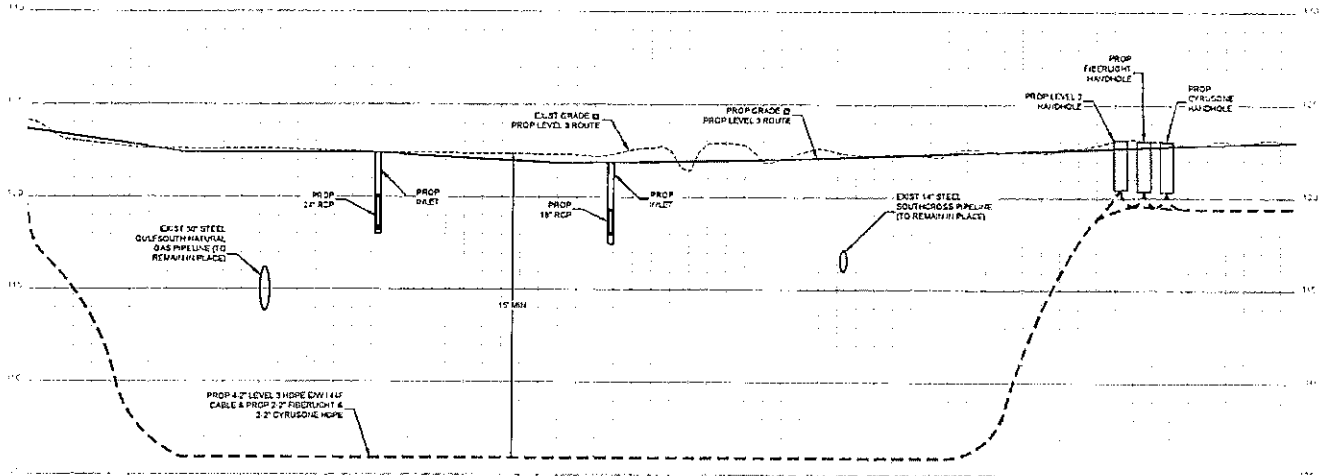

- CONSTRUCTION NOTE
CONTRACTOR MUST SUPPLY
ALL HDPE CONDUITS AS
NOTED BELOW
- 3" HDPE CONDUITATION
 - 4" LEVEL 3
 - BLACK W/ PURPLE STRIPE
 - BLACK W/ ORANGE STRIPE
 - BLACK W/ GREEN STRIPE
 - BLACK W/ BROWN STRIPE
 - 2" FIBERGLASS
 - BLACK W/ RED STRIPE
 - BLACK W/ BLUE STRIPE
 - 2" CONDUIT
 - BLACK W/ WHITE STRIPE
 - BLACK W/ GREY STRIPE

NO.	DATE	REV. REASON
1		
2		
3		

Level(3)
ENGINEERS

LEVEL 3 ENGINEER
WEST HALL
ENGINEERING FIRM
GOLDEN FIELD SERVICES

PROJECT NUMBER
LOCATION: FM 1913 ALBANY PARK
LATENOCH - HOUSTON, TX
ENGINEERING

SCALE: 1" = 10'
SHEET 11A OF 31

CONFIDENTIAL - PER PLAN

UNDERGROUND UTILITIES HAVE BEEN PLOTTED FROM AVAILABLE RECORDS AND FIELD OBSERVATION. BUT ARE NOT NECESSARILY EXACT. IT IS THE CONTRACTOR'S RESPONSIBILITY TO FIELD LOCATE ALL UNDERGROUND OBSTRUCTIONS AND UTILITIES PRIOR TO CONSTRUCTION. COMPLETE REPAIR OF ANY AND ALL DAMAGES INCURRED SHALL BE AT THE EXPENSE OF THE CONTRACTOR.



CALL BEFORE YOU DIG
1-800-541-6005
48 HOURS NOTICE REQUIRED

HOUSTON, TX
FORT BEND COUNTY



CONSTRUCTION NOTES

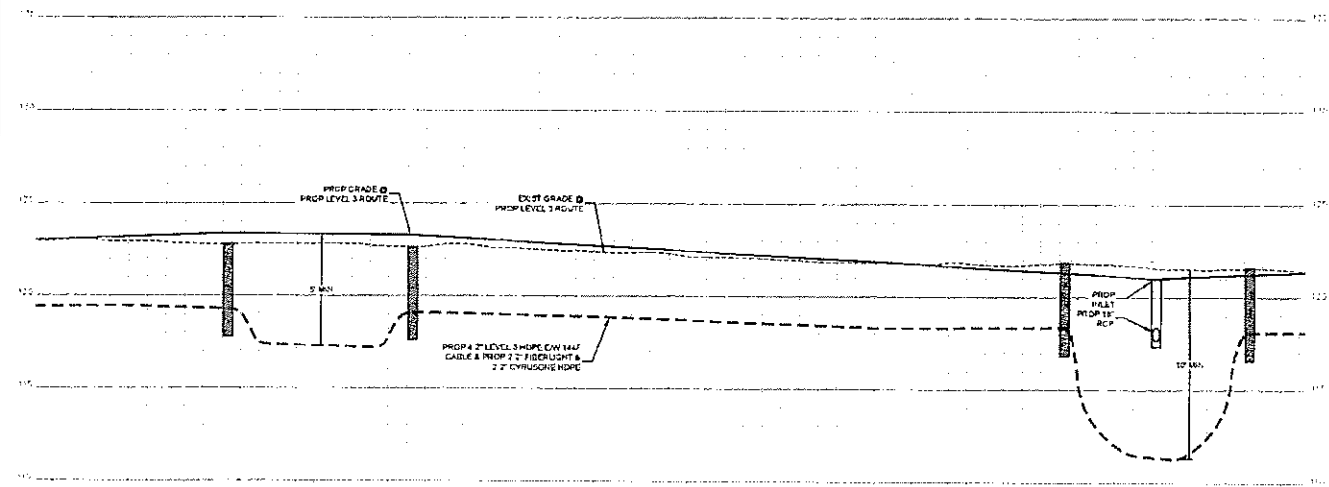

- CONTRACTOR NOTE
CONTRACTOR MUST SUPPLY
ALL HOPE CONDUITS AS
NOTED BELOW
- 8.7 HOPE CONFIGURATION
- 4.2' LEVEL(D)
 - BLACK W/ PURPLE STRIPE
 - BLACK W/ ORANGE STRIPE
 - BLACK W/ GREEN STRIPE
 - BLACK W/ BROWN STRIPE
- 2.2' FREE-RIGHT
- BLACK W/ RED STRIPE
 - BLACK W/ BLUE STRIPE
 - 2.2' GRAY/WHITE
 - BLACK W/ WHITE STRIPE
 - BLACK W/ GRAY STRIPE

1		
2		
3		

NO.	DATE	BY	REASON
1			
2			

Level(3)
CORPORATION

LEVEL ENGINEER
KEITH HALL
EX-100 (E) (R) (F) (M)
GOLDEN FIELD SERVICE
PROJECT NUMBER
LOCATION: FM 1029 W/ ST PAUL
EXTENSION - HOUSTON, TX
DATE: 02/20/2013

SCALE: VERT. 1"=3'
SHEET 12A OF 31
CONTRACT: 12A-12-12-12

UNDERGROUND UTILITIES HAVE BEEN PLOTTED FROM AVAILABLE RECORDS AND FIELD OBSERVATIONS BUT ARE NOT NECESSARILY EXACT. IT IS THE CONTRACTOR'S RESPONSIBILITY TO FIELD LOCATE ALL UNDERGROUND OBSTRUCTIONS AND UTILITIES PRIOR TO CONSTRUCTION. COMPLETE REPAIR OF ANY AND ALL DAMAGES INCURRED SHALL BE AT THE EXPENSE OF THE CONTRACTOR.



CALL BEFORE YOU DIG
1-800-543-0200
48 HOUR NOTICE REQUIRED

HOUSTON, TX
FORT BEND COUNTY



CONSTRUCTION NOTES

1. EXISTING OWNER LEVELS
CONDUIT LENGTH 100'
CONDUIT SIZE 2"
CONDUIT TYPE HDPE
NOTES: REACH 8'-2" DEPTH
2. PROPOSED OWNER LEVELS
CONDUIT LENGTH 200'
CONDUIT SIZE 2"
CONDUIT TYPE HDPE
NOTES: REACH 8'-2" DEPTH
3. CABLE MARKS: 144"
CABLE OWNER LEVELS
CABLE LENGTH 600'
NOTES: REACH 144" DEPTH

CONTRACTOR NOTE:
CONTRACTOR MUST SUPPLY
ALL HDPE CONDUITS AS
NOTED BELOW

- 4.2" HDPE CONFIGURATION
- 4.2" (LEVEL 1)
- BLACK W/ PURPLE STRIPE
- BLACK W/ ORANGE STRIPE
- BLACK W/ GREEN STRIPE
- BLACK W/ BROWN STRIPE
- 2.2" HDPE CONDUIT
- BLACK W/ RED STRIPE
- BLACK W/ BLUE STRIPE
- 3.2" HDPE CONDUIT
- BLACK W/ WHITE STRIPE
- BLACK W/ GREY STRIPE

NO.	DATE	ENG. REVISION
1		
2		
3		
4		
5		

Level(3)
LEVEL 3 ENGINEERS

LEVEL 3 ENGINEERS
10000 WESTPARK
EXTENSION - HOUSTON, TX
77060
PHONE: 281-410-1111
FAX: 281-410-1112
WWW.LEVEL3ENGINEERS.COM

SCALE: HORIZ. 1"=50'
VERT. 1"=10'
SHEET 13 OF 31
CONFIDENTIAL/PROPRIETARY

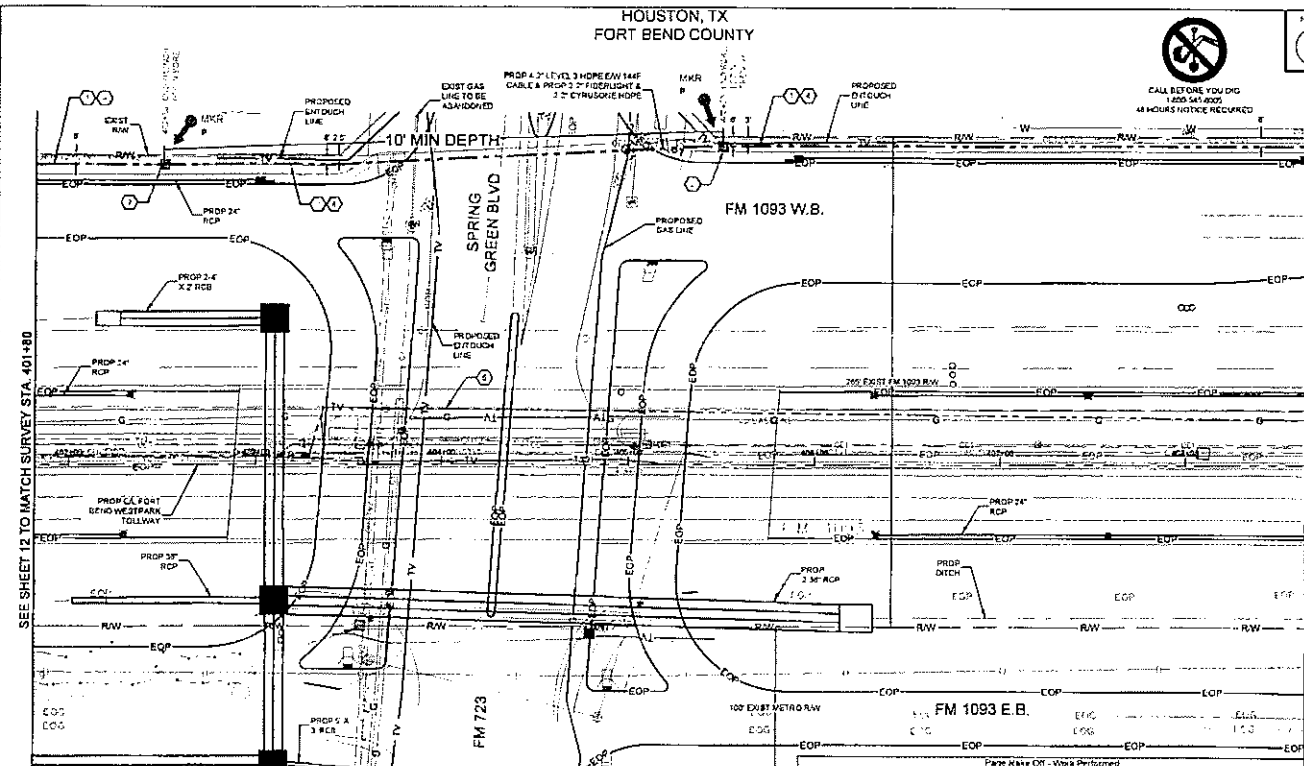

SEE SHEET 12 TO MATCH SURVEY STA. 401+80

SEE SHEET 14 TO MATCH SURVEY STA. 408+70

Unit Code & Description	Units	Quantity	Actual Quantity
MAT-00150 - CONDUIT 2" HDPE SDR 3	FT	600	
MAT-00200 - WARNING TAPS AND/OR MARKERS	EA	2	

Unit Code & Description	Units	Quantity	Actual Quantity
UGS-30050-S - TRENCH GREATER THAN 1500' TRENCH 48" MINIMUM COVER	FT	450	
UGS-30140-S - PLACE 1" HDPE CONDUITS IN OPEN TRENCH 1/4" TO 2"	FT	450	
UGS-30230-S - DIRECTIONAL BORE GREATER THAN 1500' 1" HDPE CONDUIT UP TO 2"	FT	200	
UGS-30250-S - PLACE UP TO 258 COUNT FOC IN CONDUIT UP TO 1500'	FT	600	
UGS-31840-S - EXCAVATE 1' SMALL P.T. 6"X4"X5"	EA	2	
UGS-31850-S - REMOVE AND DISPOSE OF 1.144" CABLE	FT	600	
UGS-31920-S - PLACE LOCATE MARKER POINT	EA	3	
UGS-30150-S - PLACE ADDITIONAL HDPE IN OPEN TRENCH CONDUIT UP TO 2"	FT	3,450	
UGS-30100-S - DR BORE GREATER THAN 1500' ADDITIONAL CONDUIT UP TO 2"	FT	1,420	

UNDERGROUND UTILITIES HAVE BEEN PLOTTED FROM AVAILABLE RECORDS AND FIELD OBSERVATIONS BUT ARE NOT NECESSARILY EXACT. IT IS THE CONTRACTOR'S RESPONSIBILITY TO FIELD LOCATE ALL UNDERGROUND OBSTRUCTIONS AND UTILITIES PRIOR TO CONSTRUCTION. COMPLETE REPAIR OF AUP AND ALL DAMAGES INCURRED SHALL BE AT THE EXPENSE OF THE CONTRACTOR.

HOUSTON, TX
FORT BEND COUNTY



CONSTRUCTION NOTES

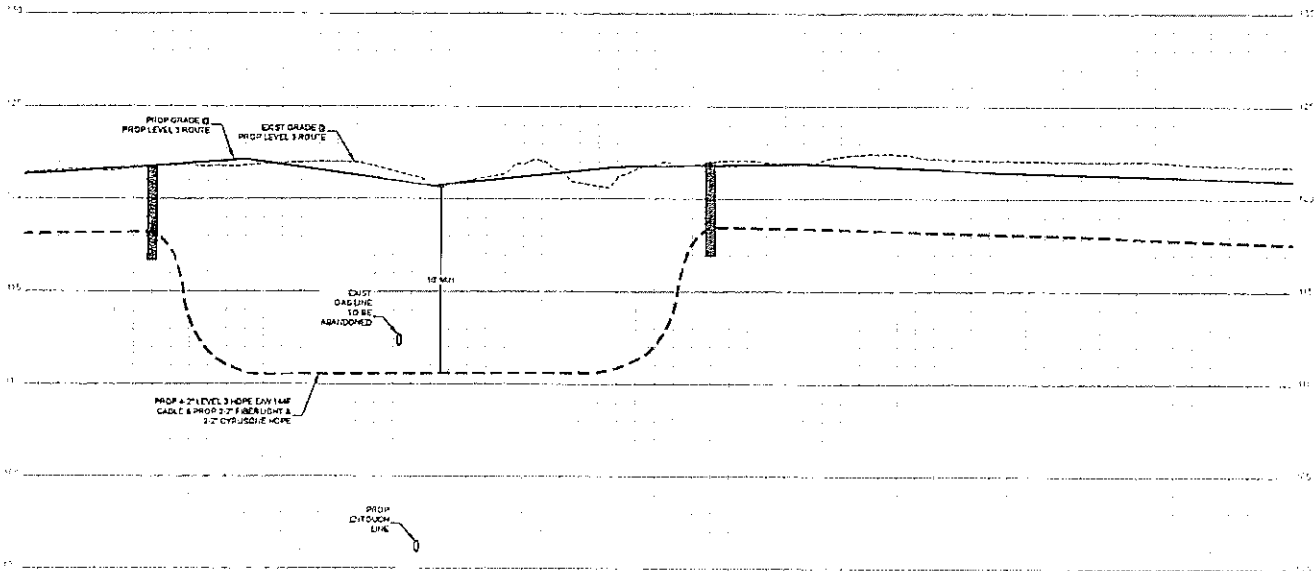

- CONTRACTOR NOTE
CONTRACTOR MUST SUPPLY
ALL HOPE CONDUITS AS
NOTED BELOW
- 8" HOPE CONFIGURATION
- 4" LEVELS
 - BLACK W/ PLAIN STRIPE
 - BLACK W/ ORANGE STRIPE
 - BLACK W/ GRN STRIPE
 - BLACK W/ BROWN STRIPE
 - 2" FIBERGLASS
 - BLACK W/ RED STRIPE
 - BLACK W/ BLUE STRIPE
 - 2" CYRUSIDE
 - BLACK W/ WHITE STRIPE
 - BLACK W/ GREY STRIPE

UNDERGROUND UTILITIES HAVE BEEN PLOTTED FROM AVAILABLE RECORDS AND
FIELD OBSERVATIONS BUT ARE NOT NECESSARILY EXACT. IT IS THE CONTRACTOR'S
RESPONSIBILITY TO FIELD LOCATE ALL UNDERGROUND OBSTRUCTIONS AND
UTILITIES PRIOR TO CONSTRUCTION. COMPLETE REPAIR OF ANY AND ALL
DAMAGED UTILITIES SHALL BE AT THE EXPENSE OF THE CONTRACTOR.



CALL BEFORE YOU DIG
1-800-541-6205
48 HOURS NOTICE REQUIRED

NO.	DATE	BY	REVISION
1			
2			
3			
4			
5			
6			
7			
8			
9			
10			
11			
12			
13			
14			
15			
16			
17			
18			
19			
20			
21			
22			
23			
24			
25			
26			
27			
28			
29			
30			
31			
32			
33			
34			
35			
36			
37			
38			
39			
40			
41			
42			
43			
44			
45			
46			
47			
48			
49			
50			
51			
52			
53			
54			
55			
56			
57			
58			
59			
60			
61			
62			
63			
64			
65			
66			
67			
68			
69			
70			
71			
72			
73			
74			
75			
76			
77			
78			
79			
80			
81			
82			
83			
84			
85			
86			
87			
88			
89			
90			
91			
92			
93			
94			
95			
96			
97			
98			
99			
100			

Level 3
LEVEL 3 ENGINEER

LEVEL 3 ENGINEER
KEITH HALL
ENGINEERING FIRM
LOCATION FIELD OFFICE
PROJECT NAME
LOCATION: FUTURE PARK
OFFICE: HOUSTON, TX
DRAWING NO.

SCALE: VERT 1"=1'
SHEET 13A OF 31
CONTRACTOR PROPERTY

HOUSTON, TX
FORT BEND COUNTY

144F
100'

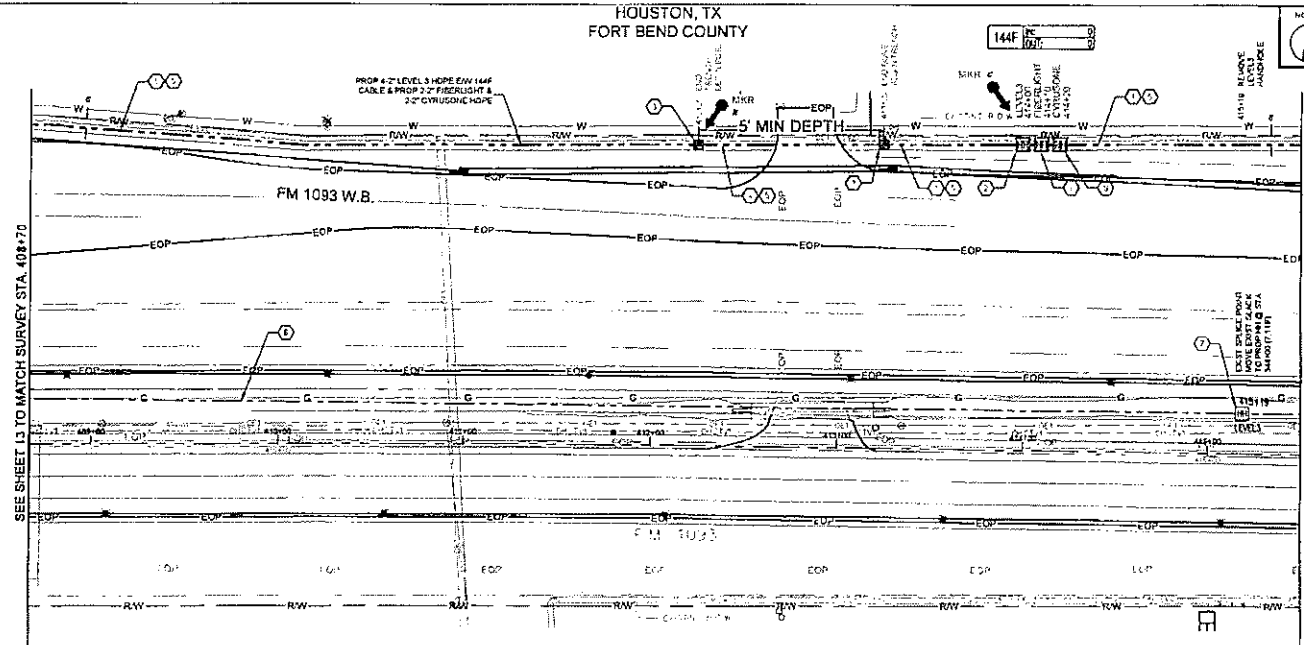

- CONSTRUCTION NOTES**
1. EXISTING OWNER LEVELS
CONDUIT LENGTH 787'
CONDUIT QTY: 8
CONDUIT TYPE: HDPE
NOTE: BORE 8-2" HOPE
 2. LEVELS: 1144F
CONDUIT LENGTH 100'
CONDUIT QTY: 1
CONDUIT TYPE: HDPE
NOTE: BORE 8-2" HOPE
 3. EXISTING OWNER LEVELS
CONDUIT LENGTH 787'
CONDUIT QTY: 8
CONDUIT TYPE: HDPE
NOTE: BORE 8-2" HOPE
 4. CABLE MARKS: 1144F
CABLE OWNER LEVELS
CABLE LENGTH 787'
NOTE: REMOVE 1144F CABLE
REPOSITION SLACK (2,114)
 5. LEVELS: 1144F
CABLE OWNER LEVELS
CABLE LENGTH 787'
NOTE: REMOVE 1144F CABLE
REPOSITION SLACK (2,114)
 6. LEVELS: 1144F
CABLE OWNER LEVELS
CABLE LENGTH 787'
NOTE: REMOVE 1144F CABLE
REPOSITION SLACK (2,114)
 7. CRANE: 1144F
CABLE OWNER LEVELS
CABLE LENGTH 787'
NOTE: REMOVE 1144F CABLE
REPOSITION SLACK (2,114)
 8. CRANE: 1144F
CABLE OWNER LEVELS
CABLE LENGTH 787'
NOTE: REMOVE 1144F CABLE
REPOSITION SLACK (2,114)

SEE SHEET 13 TO MATCH SURVEY STA. 408+70

SEE SHEET 15 TO MATCH SURVEY STA. 415+50

Page Name Qty - Materials

Unit Code & Description	Units	Quantity	Actual Quantity
MAT-90150 - CONDUIT 8-2" HDPE SDR 9	FT	682	
MAT-90970 - TIER 15 30"x48" XSP - WITH KNOCK-OUTS AND RACKING - INCLUDING COVER	EA	3	
MAT-92030 - WARNING TAGS AND/OR MARKERS	EA	2	

Page Name Qty - Work Performed

Unit Code & Description	Units	Quantity	Actual Quantity
UGB-30250-S - TRENCH GREATER THAN 1500' TRENCH 48" MAXIMUM COVER	FT	580	
UGB-30140-S - PLACE 1" HOPE CONDUITS IN OPEN TRENCH UP TO 2"	FT	580	
UGB-30280-S - UNIDIRECTIONAL BORE GREATER THAN 1500' 1" HOPE CONDUIT UP TO 2"	FT	100	
UGB-30280-S - PLACE UP TO 228 COUNT FOC IN CONDUIT, UP TO 1500' (100' IN COL)	FT	185	
UGB-31210-S - PLACE REV. 35"x48" XSP CONCRETE HANDHOLE	EA	3	
UGB-31640-S - EXCAVATE SMALL PIT 6"x6"x2	EA	2	
UGB-31050-S - REMOVE AND DISPOSE OF 1-1144F CABLE	FT	620	
UGB-31250-S - REMOVE EXISTING 30"x48" XSP CONCRETE HANDHOLE	EA	1	
UGB-31920-S - PLACE LOCATE MARKER POST	EA	2	
UGB-20150-S - PLACE ADDITIONAL HOPE IN OPEN TRENCH CONDUIT UP TO 2"	FT	400	
UGB-30700-S - DR BORE GREATER THAN 1500' ADDITIONAL CONDUIT UP TO 2"	FT	700	

UNDERGROUND UTILITIES HAVE BEEN PLOTTED FROM AVAILABLE RECORDS AND FIELD OBSERVATIONS BUT ARE NOT NECESSARILY EXACT. IT IS THE CONTRACTOR'S RESPONSIBILITY TO FIELD LOCATE ALL UNDERGROUND UTILITIES AND UTILITIES PRIOR TO CONSTRUCTION. COMPLETE REPAIR OF ANY AND ALL DAMAGES INCURRED SHALL BE AT THE EXPENSE OF THE CONTRACTOR.



CALL BEFORE YOU DIG
1-800-545-6000
48 HOURS NOTICE REQUIRED

CONTRACTOR NOTE
CONTRACTOR MUST SUPPLY
ALL HOPE CONDUITS AS
NOTED BELOW

- 8-2" HOPE CONFIGURATION
- 4-2" LEVEL(S)
 - BLACK W/ PURPLE STRIPE
 - BLACK W/ ORANGE STRIPE
 - BLACK W/ GREEN STRIPE
 - BLACK W/ BROWN STRIPE
- 2" FREEBURST
- BLACK W/ RED STRIPE
 - BLACK W/ BLUE STRIPE
- 3-2" CIVIL/ENG
- BLACK W/ WHITE STRIPE
 - BLACK W/ GREY STRIPE

Level(3)
LEVEL 3 ENGINEERS
1144F
100'

LEVEL 3 ENGINEERS
1144F
100'

ENGINEERING FIRM
COURTESY FIELD SERVICES
PROJECT NUMBER
LOCATION: FM 1093 WESTPARK
EXTENSION: 1065' FROM STA. 408+70 TO STA. 415+50

SCALE: 1"=40'
SHEET: 14 OF 31
COMPUTER: 11/18/2014

HOUSTON, TX
FORT BEND COUNTY



CONSTRUCTION NOTES

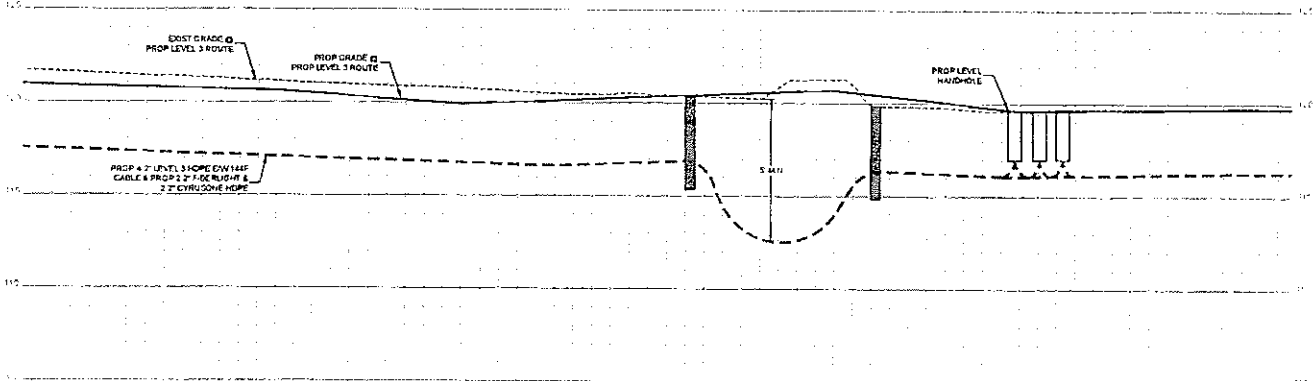

CONTRACTOR NOTE:
SIZING/FRAGMENT SUPPLY
ALL HOPE COULTS AS
NOTED BELOW.

- 5\"/>
 - 4\"/>
 - BLACK W/ PURPLE STRIPE
 - BLACK W/ ORANGE STRIPE
 - BLACK W/ GREEN STRIPE
 - BLACK W/ BROWN STRIPE
 - 2\"/>
 - BLACK W/ RED STRIPE
 - BLACK W/ BLUE STRIPE
 - 2\"/>
 - BLACK W/ WHITE STRIPE
 - BLACK W/ GREY STRIPE

NO.	DATE	BY	DESC.
1			
2			
3			

Level(3)
ENGINEERS

LEVEL 3 ENGINEER
15711 HALL
ENCHETERNO SPRING
COLUMBIA FIELD SERVICES
PROJECT NUMBER
LOCATION: FM 1071 WESTPARK
EXTENSION - HOUSTON, TX
DATE: 10/20/18

SCALE: VERT 1"=4'
SHEET 14A OF 31
EQUIPMENT: ALPHAPRINTARY

UNDERGROUND UTILITIES HAVE BEEN PLOTTED FROM AVAILABLE RECORDS AND FIELD OBSERVATIONS BUT ARE NOT NECESSARILY EXACT. IT IS THE CONTRACTOR'S RESPONSIBILITY TO FIELD LOCATE ALL UNDERGROUND OBSTRUCTIONS AND UTILITIES PRIOR TO CONSTRUCTION. COMPLETE REPAIR OF ANY AND ALL DAMAGES INCURRED SHALL BE AT THE EXPENSE OF THE CONTRACTOR.



CALL BEFORE YOU DIG
1-800-54-8025
48 HOUR NOTICE REQUIRED

HOUSTON, TX
FORT BEND COUNTY



CONSTRUCTION NOTES

1. CONDUIT OVER LVL 0.3
CONDUIT LENGTH 530'
CONDUIT DIA. 8"
CONDUIT TYPE: 1144
NOTES: 1144 8-2" HOPE
2. 1144 8-2" HOPE
3. CONDUIT OVER LVL 0.3
CONDUIT LENGTH 1147'
CONDUIT DIA. 8"
CONDUIT TYPE: 1144
NOTES: 1144 8-2" HOPE
4. CABLE 1144 1147'
CABLE OVER LVL 0.3
CABLE LENGTH 1147'
5. CABLE 1144 1147'
CABLE OVER LVL 0.3
CABLE LENGTH 1147'

- CONTRACTOR NOTE:
CONTRACTOR MUST SUPPLY
ALL HOPE CONDUITS AS
NOTED BELOW.
- 6-2" HOPE CONDUIT (1144)
 - 4.7" LEVEL:
 - BLACK W/ WHITE STRIPE
 - BLACK W/ ORANGE STRIPE
 - BLACK W/ GREEN STRIPE
 - BLACK W/ BROWN STRIPE
 - 2.2" FIBERGLASS
 - BLACK W/ RED STRIPE
 - BLACK W/ BLUE STRIPE
 - 2" CYRUS (1144)
 - BLACK W/ WHITE STRIPE
 - BLACK W/ GREY STRIPE

NO.	DATE	ENG. DESIGN
1	11-13-13	AS-BUILT
2	2-2-15	REVISION # 1
3	11-13-15	ORIGINAL
4	02-02-16	CONDUIT

Level (3)
ENGINEERING
LEVEL 3 ENGINEER
REGISTERED PROFESSIONAL ENGINEER
NO. 11447
LOCATION: FM 1093 WESTPARK
EXTENSION, HOUSTON TX
11-13-13

SCALE: HORIZ 1"=50'
SHEET 15 OF 31
CONTRACT: 150121001

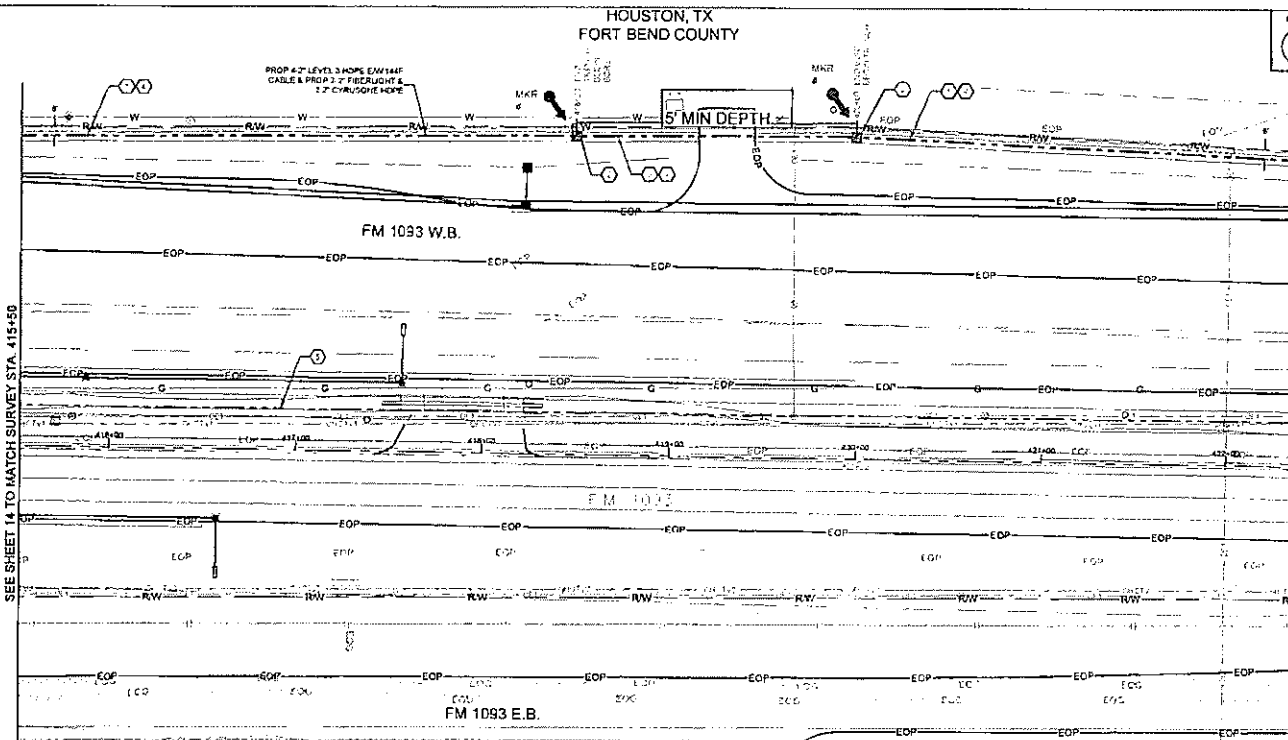

SEE SHEET 14 TO MATCH SURVEY STA. 415+50

SEE SHEET 16 TO MATCH SURVEY STA. 422+30

Unit Code & Description	Units	Estimated Quantity	Actual Quantity
MAT-30150 - CONDUIT 8" HOPE EDR 9	FT	650	
MAT-32020 - WARNING TABS AND/OR MARKERS	EA	2	

Unit Code & Description	Units	Estimated Quantity	Actual Quantity
UGD-30050-S TRENCH GREATER THAN 1500' TRENCH 48" MINIMUM COVER	LF	530	
UGD-30140-S PLACE 1 HOPE CONDUITS IN OPEN TRENCH UP TO 2"	FT	530	
UGD-30050-S DIRECTIONAL BORE GREATER THAN 1500' 1 HOPE CONDUIT UP TO 2"	FT	150	
UGD-30050-S PLACE UP TO 288 COUNT FIBER IN CONDUIT UP TO 1500'	FT	530	
UGD-31640-S EXCAVATE SMALL PIT EXAKS	EA	2	
UGD-31050-S REMOVE AND DISPOSE OF 1-1144 CABLE	FT	530	
UGD-31900-S PLACE LOCATE MARKER POST	EA	2	
UGD-30150-S PLACE ADDITIONAL HOPE IN OPEN TRENCH CONDUIT UP TO 2"	FT	3,710	
UGD-30150-S DR BORE GREATER THAN 1500' ADDITIONAL CONDUIT UP TO 2"	FT	1,050	



CALL BEFORE YOU DIG
1-800-4-A-DIG
48 HOURS NOTICE REQUIRED

UNDERGROUND UTILITIES HAVE BEEN PLOTTED FROM AVAILABLE RECORDS AND FIELD OBSERVATIONS BUT ARE NOT NECESSARILY EXACT. IT IS THE CONTRACTOR'S RESPONSIBILITY TO FIELD LOCATE ALL UNDERGROUND OBSTRUCTIONS AND UTILITIES PRIOR TO CONSTRUCTION. COMPLETE REPAIR OF ANY AND ALL DAMAGES INCURRED SHALL BE AT THE EXPENSE OF THE CONTRACTOR.

HOUSTON, TX
FORT BEND COUNTY



CONSTRUCTION NOTES

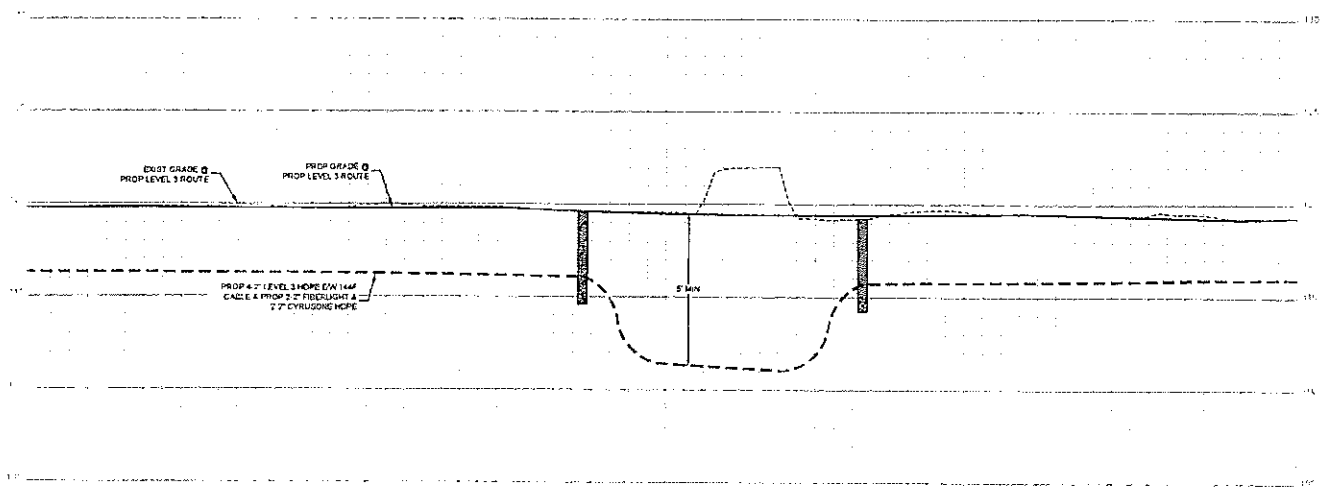

- CONTRACTOR NOTE
CONTRACTOR MUST SUPPLY
ALL HOPE COORDS AS
NOTED BELOW
- 4.2" HOPE CONFIGURATION:
- 4.2" LEVEL(1)
 - BLACK W/ PURPLE STRIPE
 - BLACK W/ ORANGE STRIPE
 - BLACK W/ GREEN STRIPE
 - BLACK W/ BROWN STRIPE
 - 2" FIBERGLASS
 - BLACK W/ RED STRIPE
 - BLACK W/ BLUE STRIPE
 - 2" CYAN/SLK
 - BLACK W/ WHITE STRIPE
 - BLACK W/ GREY STRIPE

1		
2		
3		
NO	DATE	END DESIGN
1-2-11	PERSON # 1	
11-12-11	PERSON	
DRAWING	COMMENT	

Level(3)
LEVEL 3 ENGINEER
KEITH HALL
1404 KIRKWOOD FARM
CONCRETE FIELD SERVICES
PROJECT NUMBER
LOCATION: FM 1753 WESTPARK
EXTENSION HOUSTON, TX
DRAWN BY: NAME

SCALE: VERT. 1"=4'
SHEET 15A OF 31
CONFIDENTIAL/PROPRIETARY

UTILITY/UNDERGROUND UTILITIES HAVE BEEN PLOTTED FROM AVAILABLE RECORDS AND FIELD OBSERVATIONS BUT ARE NOT NECESSARILY EXACT. IT IS THE CONTRACTOR'S RESPONSIBILITY TO FIELD LOCATE ALL UNDERGROUND OBSTRUCTIONS AND UTILITIES PRIOR TO CONSTRUCTION. COMPLETE REPAIR OF ANY AND ALL DAMAGES INCURRED SHALL BE AT THE EXPENSE OF THE CONTRACTOR.



CALL BEFORE YOU DIG
1-800-345-6205
88-24-REVISION OF 8/20/08

HOUSTON, TX
FORT BEND COUNTY

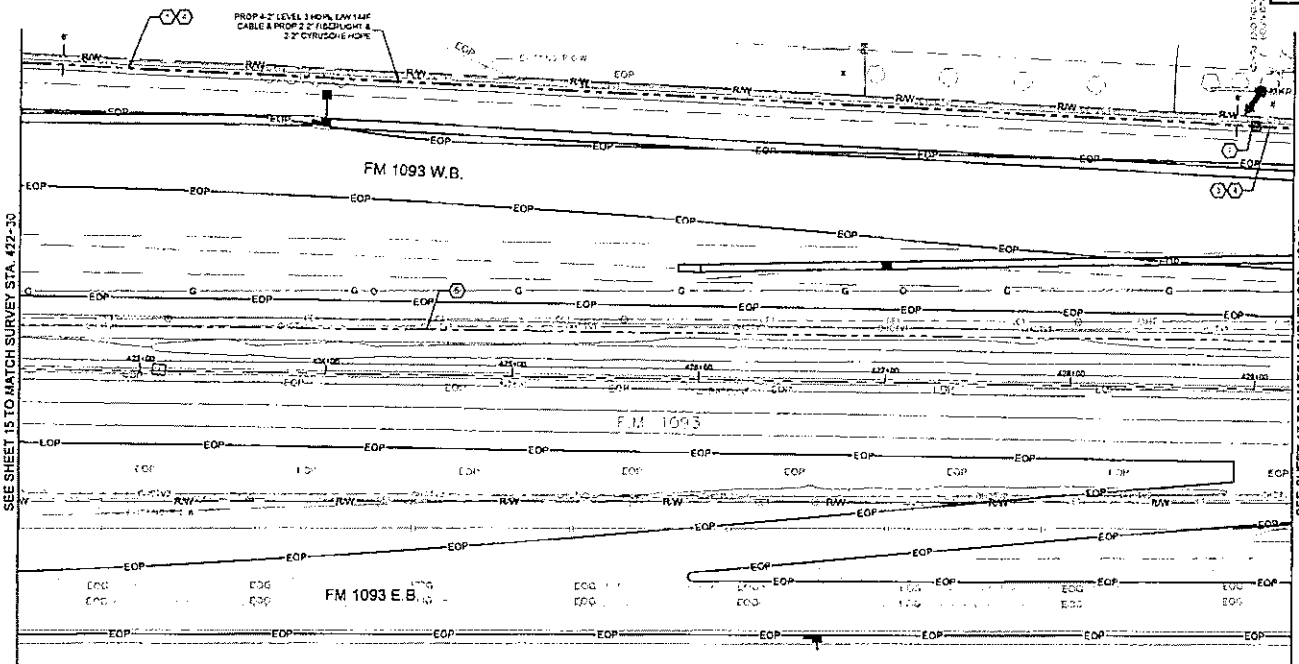

- CONSTRUCTION NOTES**
1. EXIST OWNER LEVELS
CONDUIT LOCUS: 8"
CONDUIT SIZE: 8"
CONDUIT TYPE: HOPE
NOTE: TRENCH 8"-2" HOPE
 2. EXIST OWNER LEVELS
CONDUIT LOCUS: 37"
CONDUIT SIZE: 8"
CONDUIT TYPE: HOPE
NOTE: SEE 8"-2" HOPE
 3. EXIST OWNER LEVELS
CONDUIT LOCUS: 144"
CONDUIT SIZE: 144"
CONDUIT TYPE: HOPE
NOTE: MARK 144" CABLE

SEE SHEET 15 TO MATCH SURVEY STA. 422+30

SEE SHEET 17 TO MATCH SURVEY STA. 429+20

Page Make Of: Water's

UM Code & Description	Units	REQUIRE QUANTITY	ACTUAL QUANTITY
MAT-80150 - CONDUIT 8"-2" HOPE SDR 9	FT	630	
MAT-02000 - WARNING TAGS AND/OR MARKERS	EA	1	

Page Make Of: Work Performed

UM Code & Description	Units	REQUIRE QUANTITY	ACTUAL QUANTITY
UCB-32260-S - TRENCH GREATER THAN 1500' TRENCH 48" MINIMUM COVER	FT	630	
UCB-30140-S - PLACE 1" HOPE CONDUITS IN OPEN TRENCH UP TO 2"	FT	670	
UCB-30090-S - DIRECTIONAL BORE GREATER THAN 1500' 1 HOPE CONDUIT UP TO 2"	FT	20	
UCB-30250-S - PLACE UP TO 255 COUNT FOC IN CONDUIT UP TO 1500'	FT	630	
UCB-31640-S - EXCAVATE SMALL PIT 6'X4'X2'	EA	1	
UCB-31050-S - REMOVE AND DISPOSE CP 1-144" CABLE	FT	000	
UCB-31990-S - PLACE LOCATE MARKER POET	EA	1	
UCB-32150-S - PLACE ADDITIONAL HOPE IN OPEN TRENCH CONDUIT UP TO 2"	FT	400	
UCB-32100-S - DIR BORE GREATER THAN 1500' ADDITIONAL HOPE UP TO 2"	FT	140	

UNDERGROUND UTILITIES HAVE BEEN PLOTTED FROM AVAILABLE RECORDS AND FIELD OBSERVATION BUT ARE NOT NECESSARILY EXACT. IT IS THE CONTRACTOR'S RESPONSIBILITY TO FIELD LOCATE ALL UNDERGROUND OBSTRUCTIONS AND UTILITIES PRIOR TO CONSTRUCTION. COMPLETE REPAIR OF ANY AND ALL DAMAGES INCURRED SHALL BE AT THE EXPENSE OF THE CONTRACTOR.



- CONTRACTOR NOTE**
CONTRACTOR MUST SUPPLY ALL HOPE CONDUITS AS NOTED BELOW
- 8"-2" HOPE CONFIGURATION
- 4" LEVELS
 - BLACK W/ PURPLE STRIPE
 - BLACK W/ ORANGE STRIPE
 - BLACK W/ GREEN STRIPE
 - BLACK W/ BROWN STRIPE
- 2" FACE LIGHT
- BLACK W/ RED STRIPE
 - BLACK W/ BLUE STRIPE
 - 3" CYRUSHOPE
 - BLACK W/ WHITE STRIPE
 - BLACK W/ GREY STRIPE

Level(3)

LEVEL ENGINEER
KATHY HALL
REGISTERED PROFESSIONAL ENGINEER
COLUMBIA FIELD SERVICE
PROJECT NUMBER
LOCATION: FM 1093 WESTPARK
EXTENSION, HOUSTON, TX
724095270200

SCALE: HORIZ 1"=10'
SHEET 16 OF 31
CONTRACT: 144010001001

HOUSTON, TX
FORT BEND COUNTY



CONSTRUCTION NOTES

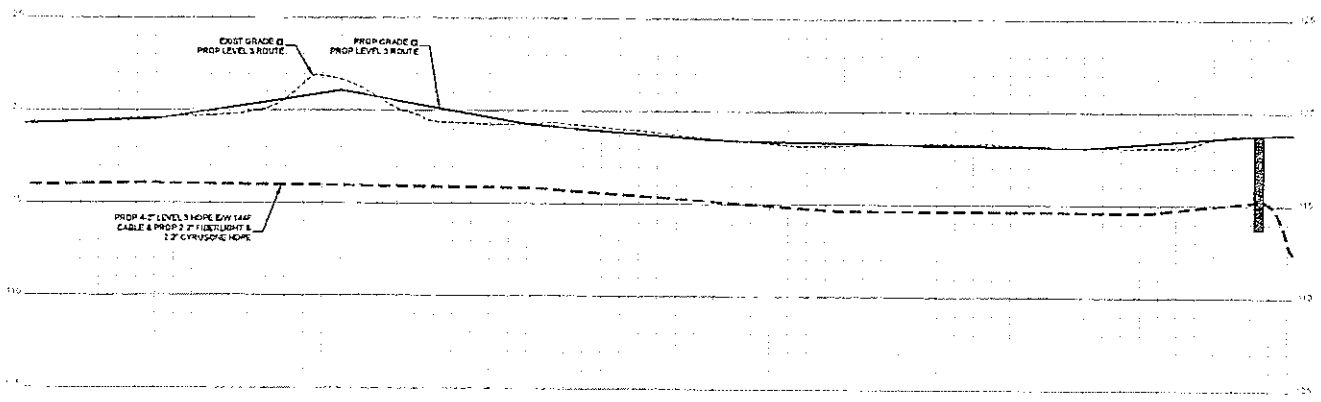

- CONTRACTOR NOTE
CONTRACTOR SHALL SUPPLY
ALL HORPE CONFIGURATIONS AS
NOTED BELOW
- 6-2" HORPE CONFIGURATION
 - 4-1" LEVEL(1)
 - BLACK W/ PURPLE STRIPE
 - BLACK W/ ORANGE STRIPE
 - BLACK W/ GREEN STRIPE
 - BLACK W/ BROWN STRIPE
 - 2" FIBER LIGHT
 - BLACK W/ RED STRIPE
 - BLACK W/ BLUE STRIPE
 - 2" FIBER OPTIC
 - BLACK W/ WHITE STRIPE
 - BLACK W/ GRAY STRIPE

NO.	DATE	DESCRIPTION
1		AS-BUILT
2-2018		REVISION # 1
11-15-18		ISSUED FOR PERMIT
04-17-19		ISSUED FOR CONSTRUCTION

Level(3)
REGISTERED PROFESSIONAL ENGINEER

LEVEL(3) ENGINEER
REGISTERED PROFESSIONAL ENGINEER
ENGINEERING FIRM
GOLDEN FIELD SERVICES
PROJECT NUMBER
LOCATION: FM 1351 WESTPARK
DATE: 11/15/18
HOUSTON, TX
FOOTNOTES

SCALE: VERT 1"=5'
SHEET 16A OF 31
CONFIDENTIAL/RESERVED

UNDERGROUND UTILITIES HAVE BEEN PLOTTED FROM AVAILABLE RECORDS AND FIELD OBSERVATIONS BUT ARE NOT NECESSARILY EXACT. IT IS THE CONTRACTOR'S RESPONSIBILITY TO FIELD LOCATE ALL UNDERGROUND OBSTRUCTIONS AND UTILITIES PRIOR TO CONSTRUCTION. COMPLETE REPAIR OF ANY AND ALL DAMAGES INCURRED SHALL BE AT THE EXPENSE OF THE CONTRACTOR.



CALL BEFORE YOU DIG
1-800-545-6009
48 HOUR NOTICE REQUIRED

HOUSTON, TX
FORT BEND COUNTY



CONSTRUCTION NOTES

1. CONDUIT OWNER LEVELS
CONDUIT LENGTH MAY
VARY 0.5%
CONDUIT SIZE 2"
CONDUIT TYPE: HDPE
NOTES: RACE 8-2" HDPE
2. CONDUIT OWNER LEVELS
CONDUIT LENGTH MAY
VARY 0.5%
CONDUIT SIZE 2"
CONDUIT TYPE: HDPE
NOTES: RACE 8-2" HDPE
3. CABLE PILES: 1.5"
CABLE OWNER LEVELS
CABLE LENGTH MAY
VARY 0.5%
NOTES: RACE 1.5" CABLE

- CONTRACTOR NOTE:
CONTRACTOR MUST SUPPLY
ALL HOPE CONDUITS AS
NOTED BELOW.
- 8-2" HOPE CONFIGURATION
4-2" LEVEL (1)
 - BLACK W/ PURPLE STRIPE
 - BLACK W/ ORANGE STRIPE
 - BLACK W/ GREEN STRIPE
 - BLACK W/ BROWN STRIPE
 - 2" FIBERGLASS
 - BLACK W/ RED STRIPE
 - BLACK W/ BLUE STRIPE
 - 2" CYRUS HDPE
 - BLACK W/ WHITE STRIPE
 - BLACK W/ GREY STRIPE

Level (3)

LEVEL 3 ENGINEER
MAY 11, 2011
PROJECT NUMBER:
LOCATION: FM 1093 WESTPARK
RATONOH, HOUSTON, TX
DATE: NOV 11, 2010
SHEET 17 OF 31
CONTRACT: 14610001000

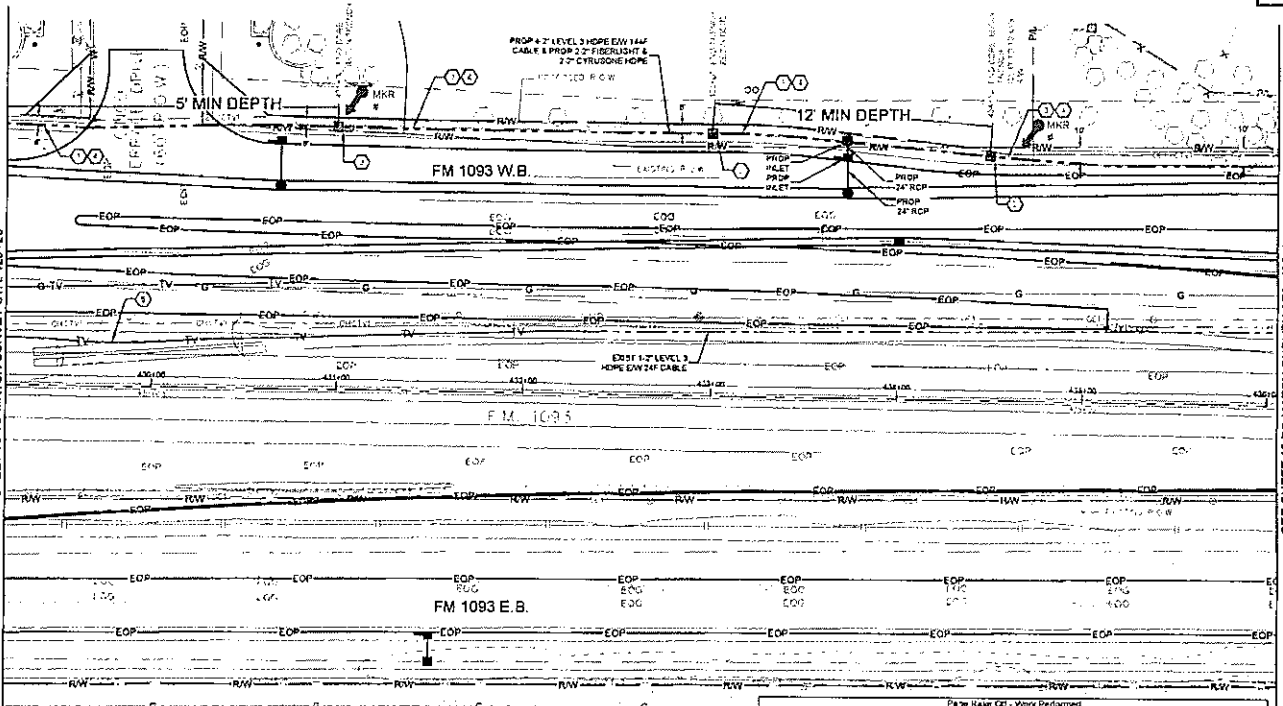

SEE SHEET 15 TO MATCH SURVEY STA. 428+20

SEE SHEET 18 TO MATCH SURVEY STA. 438+10



CALL BEFORE YOU DIG
1-800-545-6225
48 HOURS NOTICE REQUIRED

UNDERGROUND UTILITIES HAVE BEEN PLOTTED FROM AVAILABLE RECORDS AND FIELD OBSERVATIONS BUT ARE NOT NECESSARILY EXACT. IT IS THE CONTRACTOR'S RESPONSIBILITY TO FIELD LOCATE ALL UNDERGROUND OBSTRUCTIONS AND UTILITIES PRIOR TO CONSTRUCTION. COMPLETE REPAIR OF ANY AND ALL DAMAGES INCURRED SHALL BE AT THE EXPENSE OF THE CONTRACTOR.

Page Name	Qty	Material	Units	Quantity	Actual Quantity
MAT-50150 - CONDUIT 8-2" HDPE CDR 3			FT	650	
MAT-80250 - WARNING TAGS AND/OR MARKERS			EA	2	

Page Name	Qty	Work Performed	Units	Quantity	Actual Quantity
UCB-3000-S - TRENCH GREATER THAN 1500' TRENCH 48" MINIMUM COVER			FT	300	
UCB-33140-S - PLACE 1- HOPE CONDUITS IN OPEN TRENCH UP TO 2'			FT	300	
UCB-3000-S - REGIONAL BORE GREATER THAN 1500' 1 HOPE CONDUIT UP TO 2'			FT	300	
UCB-3000-S - PLACE UP TO 2M COUNT FOC IN CONDUIT UP TO 1500'			FT	600	
UCB-31640-S - EXCAVATE SMALL PIT 6'x4'x5'			EA	3	
UCB-31020-S - REMOVE AND DISPOSE OF 1-1.544' CABLE			LF	630	
UCB-31020-S - PLACE LOCATE MARKER POST			EA	2	
UCB-30120-S - PLACE ADDITIONAL HOPE IN OPEN TRENCH CONDUIT UP TO 2'			FT	2,670	
UCB-30120-S - 0-R BORE GREATER THAN 1500' ADDITIONAL CONDUIT UP TO 2'			FT	2,310	

HOUSTON, TX
FORT BEND COUNTY



CONSTRUCTION NOTES

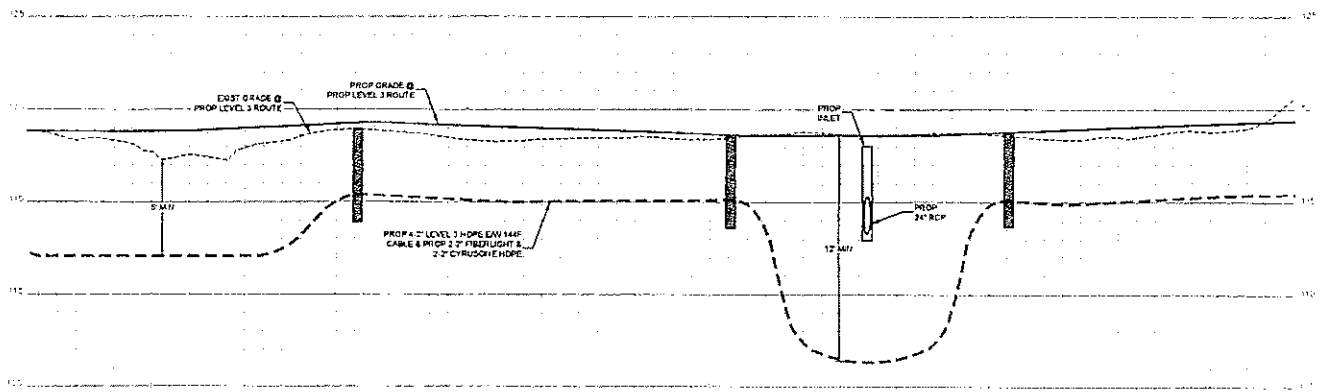

- CONTRACTOR NOTE:
CONTRACTOR MUST SUPPLY ALL HOPE CONFIGS AS NOTED BELOW
- 5-2" HOPE CONFIGURATION
- 4-2" LEVELS
 - BLACK W/ PURPLE STRIPE
 - BLACK W/ ORANGE STRIPE
 - BLACK W/ GREEN STRIPE
 - BLACK W/ BROWN STRIPE
 - 2-2" FIBERGLASS
 - BLACK W/ RED STRIPE
 - BLACK W/ BLUE STRIPE
 - 2-2" FRUSON-C
 - BLACK W/ WHITE STRIPE
 - BLACK W/ GREY STRIPE

1	
2	
3	
NO DATE	ONE DESIGN
2-2-18	AS-BUILT
11-13-13	REVISION # 1
	ORIGINAL
	CONSENT

Level(3)
CORPORATION

LEVEL 3 ENGINEER
KEITH HALL
ENGINEERING FIRM
COURTESY FIELD SERVICES
PROJECT NUMBER
LOCATION: 150 WEST PARK
EXTENSION - HOUSTON, TX
DRAWING NO.

SCALE: 1" = 1'-0"
SHEET 17A OF 31
CDDUTW17A-17A-17A-17A

UNDERGROUND UTILITIES HAVE BEEN PLOTTED FROM AVAILABLE RECORDS AND FIELD OBSERVATIONS BUT ARE NOT NECESSARILY EXACT. IT IS THE CONTRACTOR'S RESPONSIBILITY TO FIELD LOCATE ALL UNDERGROUND OBSTRUCTIONS AND UTILITIES PRIOR TO CONSTRUCTION. COMPLETE REPAIR OF ANY AND ALL DAMAGES INCURRED SHALL BE AT THE EXPENSE OF THE CONTRACTOR.



CALL BEFORE YOU DIG
1-800-545-4545
48 HOUR NOTICE REQUIRED

HOUSTON, TX
FORT BEND COUNTY



144F
100' 0'

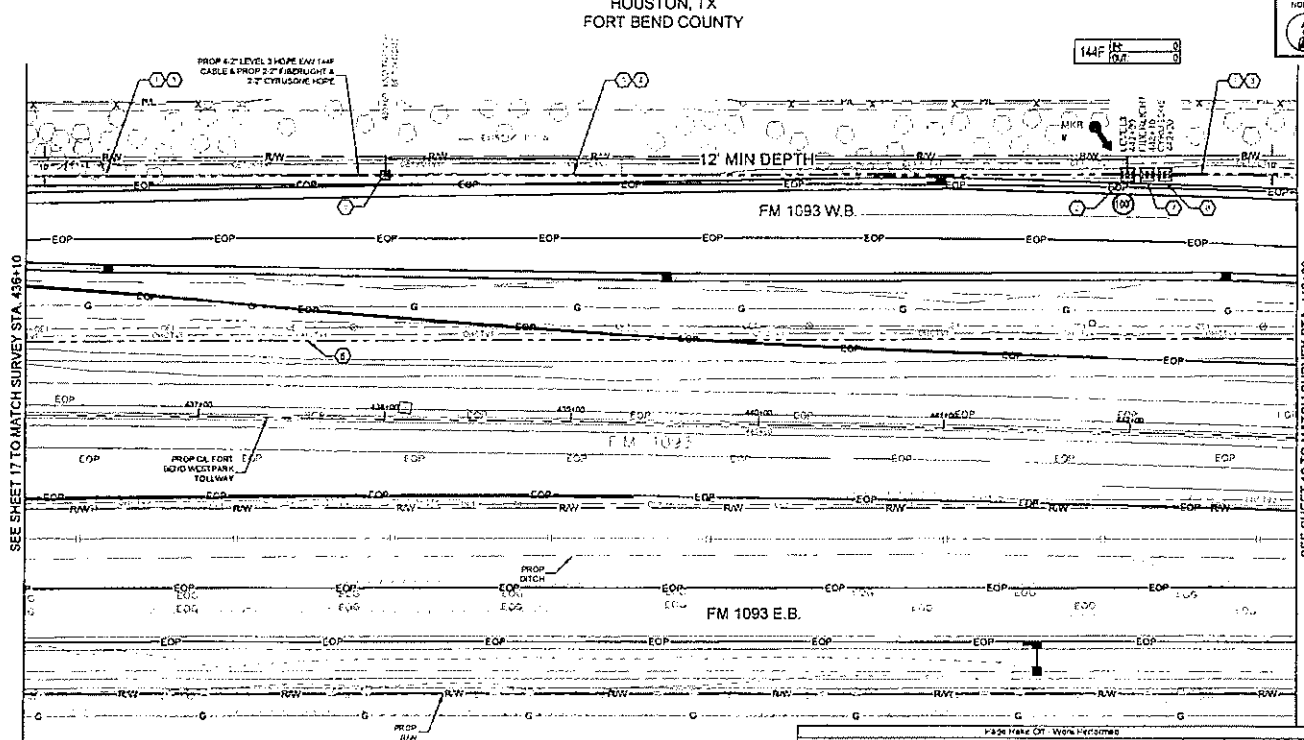

SEE SHEET 17 TO MATCH SURVEY STA. 436+10

SEE SHEET 18 TO MATCH SURVEY STA. 442+80

- CONSTRUCTION NOTES**
- 1. CONDUIT UNDER LEVELS EXHIBIT UNDER LEVELS SEE OFF. 6
 - 2. CONDUIT UNDER LEVELS EXHIBIT UNDER LEVELS SEE OFF. 6
 - 3. CONDUIT UNDER LEVELS EXHIBIT UNDER LEVELS SEE OFF. 6
 - 4. CONDUIT UNDER LEVELS EXHIBIT UNDER LEVELS SEE OFF. 6
 - 5. CONDUIT UNDER LEVELS EXHIBIT UNDER LEVELS SEE OFF. 6
 - 6. CONDUIT UNDER LEVELS EXHIBIT UNDER LEVELS SEE OFF. 6
 - 7. CONDUIT UNDER LEVELS EXHIBIT UNDER LEVELS SEE OFF. 6
 - 8. CONDUIT UNDER LEVELS EXHIBIT UNDER LEVELS SEE OFF. 6
 - 9. CONDUIT UNDER LEVELS EXHIBIT UNDER LEVELS SEE OFF. 6
 - 10. CONDUIT UNDER LEVELS EXHIBIT UNDER LEVELS SEE OFF. 6
 - 11. CONDUIT UNDER LEVELS EXHIBIT UNDER LEVELS SEE OFF. 6
 - 12. CONDUIT UNDER LEVELS EXHIBIT UNDER LEVELS SEE OFF. 6
 - 13. CONDUIT UNDER LEVELS EXHIBIT UNDER LEVELS SEE OFF. 6
 - 14. CONDUIT UNDER LEVELS EXHIBIT UNDER LEVELS SEE OFF. 6
 - 15. CONDUIT UNDER LEVELS EXHIBIT UNDER LEVELS SEE OFF. 6
 - 16. CONDUIT UNDER LEVELS EXHIBIT UNDER LEVELS SEE OFF. 6
 - 17. CONDUIT UNDER LEVELS EXHIBIT UNDER LEVELS SEE OFF. 6
 - 18. CONDUIT UNDER LEVELS EXHIBIT UNDER LEVELS SEE OFF. 6
 - 19. CONDUIT UNDER LEVELS EXHIBIT UNDER LEVELS SEE OFF. 6
 - 20. CONDUIT UNDER LEVELS EXHIBIT UNDER LEVELS SEE OFF. 6

- CONSTRUCTION NOTE**
CONTRACTOR MUST SUPPLY ALL HOPE CONDUITS AS NOTED BELOW
- 4" HOPE CONFIGURATION
- 4" LEVEL (L)
 - BLACK W/PURPLE STRIPE
 - BLACK W/ORANGE STRIPE
 - BLACK W/GREEN STRIPE
 - BLACK W/BROWN STRIPE
 - 3" FIBERGLASS
 - BLACK W/RED STRIPE
 - BLACK W/BLUE STRIPE
 - 3" CURBSTONE
 - BLACK W/WHITE STRIPE
 - BLACK W/GRAY STRIPE

Page Make Off - Materials

Unit Code & Description	UNITS	Estimated Quantity	Actual Quantity
MAT-00150 - CONDUIT 4" HOPE SDR 8	FT	650	
MAT-00370 - TIER 15 30"x45"x30" - WITH HOOK-OUTS AND RACKING - INCLUDING COVER	EA	3	
MAT-00200 - WARNING TAGS AND/OR MARKERS	EA	1	

Page Make Off - Work Performance

Unit Code & Description	Units	Estimated Quantity	Actual Quantity
UGB-13055-S - TRENCH GREATER THAN 1500' TRENCH 48" MINIMUM COVER	FT	250	
UGB-10145-G - PLACE 1" HOPE CONDUITS IN OPEN TRENCH UP TO 2"	FT	250	
UGB-10030-S - DIRECTIONAL BORE GREATER THAN 1500' 1 HOPE CONDUIT UP TO 2"	FT	400	
UGB-30955-G - PLACE UP TO 285 CONDUIT (60 IN CONDUIT UP TO 1500' (100' IN CO L))	FT	780	
UGB-31270-S - PLACE (NEW 30"x45"x30" - NON-CONCRETE HANDHOLE	EA	3	
UGB-31040-S - EXCAVATE 6" ALL PIT EXCAV	EA	1	
UGB-31050-S - REMOVE AND DISPOSEL OF 1-1/4" CABLE	FT	650	
UGB-31020-S - PLACE LOCATE WARNER POST	EA	1	
UGB-32150-S - PLACE ADDITIONAL HOPE IN OPEN TRENCH CONDUIT UP TO 2"	FT	1850	
UGB-32700-S - DR BORE GREATER THAN 100' ADDITIONAL CONDUIT UP TO 2"	FT	2500	

UNDERGROUND UTILITIES HAVE BEEN PLOTTED FROM AVAILABLE RECORDS AND FIELD OBSERVATIONS BUT ARE NOT NECESSARILY EXACT. IT IS THE CONTRACTOR'S RESPONSIBILITY TO FIELD LOCATE ALL UNDERGROUND OBSTRUCTIONS AND UTILITIES PRIOR TO CONSTRUCTION. COMPLETE REPAIR OF ANY AND ALL DAMAGES INCURRED SHALL BE AT THE EXPENSE OF THE CONTRACTOR.



CALL BEFORE YOU DIG
1-800-4-A-DIG
48 HOUR NOTICE REQUIRED

Level (3)

LEVEL ENGINEER
KATHY HALL

EXAMINING ENGINEER
COLLEEN FIELD SERVICE

PROJECT NUMBER
LOCATION: FM 1093 WESTRANK
EXTENSION HOUSTON TX

SCALE: HOR 1"=50'

SHEET 18 OF 31

CONFIDENTIAL/PROPRIETARY

HOUSTON, TX
FORT BEND COUNTY



CONSTRUCTION NOTES

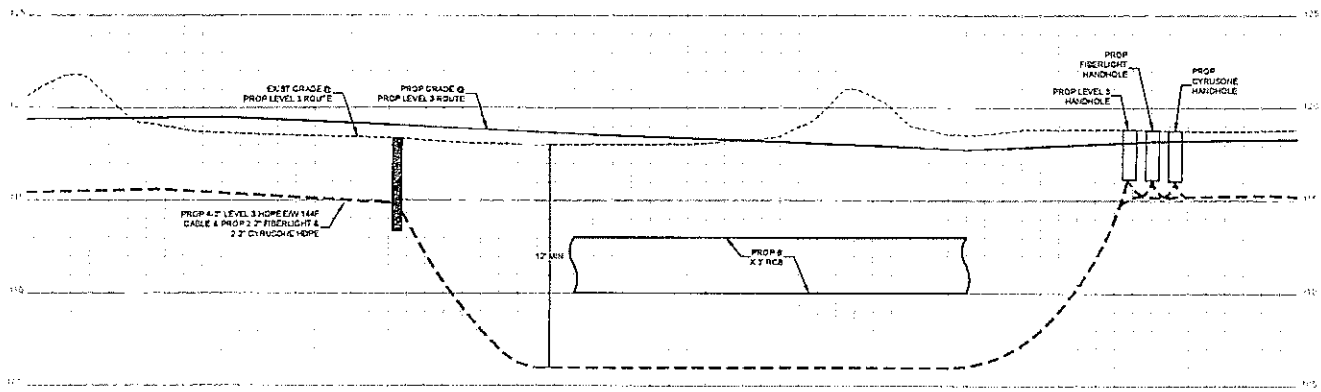

- CONTRACTOR TO FURNISH
CONTRACTOR TO SUPPLY
ALL HOPE COILS AS
NOTED BELOW
- HOPE COIL CONFIGURATION
- 4" FIBERHOLE
 - BLACK W/ PURPLE STRIPE
 - BLACK W/ ORANGE STRIPE
 - BLACK W/ YELLOW STRIPE
 - BLACK W/ BROWN STRIPE
 - 2" FIBERHOLE
 - BLACK W/ RED STRIPE
 - BLACK W/ BLUE STRIPE
 - 2" CYRUSOHE
 - BLACK W/ WHITE STRIPE
 - BLACK W/ GREY STRIPE

NO.	DATE	END SHEET
1		
2		
3		
4		
5		
6		
7		
8		
9		
10		
11		
12		
13		
14		
15		
16		
17		
18		
19		
20		
21		
22		
23		
24		
25		
26		
27		
28		
29		
30		
31		
32		
33		
34		
35		
36		
37		
38		
39		
40		
41		
42		
43		
44		
45		
46		
47		
48		
49		
50		

Level(3)
SURVEYING

LEVEL ENGINEER
KEITH HALL

REGISTERED PROFESSIONAL SURVEYOR
GOLDEN FELD SURVEYING

PROJECT NUMBER
LOCATION: FM 1055 WESTRAMP
EXTENSION - HOUSTON, TX

DATE: 11/13/15

SCALE: VERT. 1"=3'

SHEET 18A OF 31

CONVENTIONAL RECORD DRAWING



CALL BEFORE YOU DIG
1-800-4-A-DIG
48-HOUR NOTICE ALLOWED

UNDERGROUND UTILITIES HAVE BEEN PLOTTED FROM AVAILABLE RECORDS AND FIELD OBSERVATIONS BUT ARE NOT NECESSARILY EXACT. IT IS THE CONTRACTOR'S RESPONSIBILITY TO FIELD LOCATE ALL UNDERGROUND OBSTRUCTIONS AND UTILITIES PRIOR TO CONSTRUCTION. COMPLETE REPAIR OF ANY AND ALL DAMAGES INCURRED SHALL BE AT THE EXPENSE OF THE CONTRACTOR.

HOUSTON, TX
FORT BEND COUNTY



CONSTRUCTION NOTES

- 1 CONDUIT OVER 1.000.5
CONDUIT LENGTH MUST
INCLUDE 20'-0"
CONDUIT 20'-0"
CONDUIT 20'-0"
CONDUIT 20'-0"
NOTE: REMOVE 8'-0" HOPE
- 2 CABLE FROM 1.447
CABLE OVER 1.000.5
CABLE LENGTH 800'
NOTE: REMOVE 1.447
- 3 CABLE FROM 1.447
CABLE OVER 1.000.5
CABLE LENGTH 800'
NOTE: REMOVE 1.447

CONTRACTOR NOTE
CONTRACTOR MUST SUPPLY
ALL HOPE CONFIGURATIONS
AS NOTED BELOW

- 4' HOPE CONFIGURATION
- 4" LEVELLED
- BLACK W/ PURPLE STRIPE
- BLACK W/ ORANGE STRIPE
- BLACK W/ GREEN STRIPE
- BLACK W/ BROWN STRIPE
- 2" FIBERGLASS
- BLACK W/ RED STRIPE
- BLACK W/ BLUE STRIPE
- 2" CYRUSGONE
- BLACK W/ WHITE STRIPE
- BLACK W/ GREY STRIPE

NO.	DATE	ENG. DESIGN
1		
2		
3		
4		
5		

Level(3)
LEVEL ENGINEER

WESTPARK
ENGINEERING FIRM
CONDUCT FIELD SERVICES
PROJECT MANAGER
LOCATION: FM 1093 WESTPARK
EXTENSION HOUSTON, TX
DRAWN BY: JMC

SCALE: HORIZ 1"=50'
SHEET 13 OF 31
DATE: 02/27/2014 09:45:00 AM

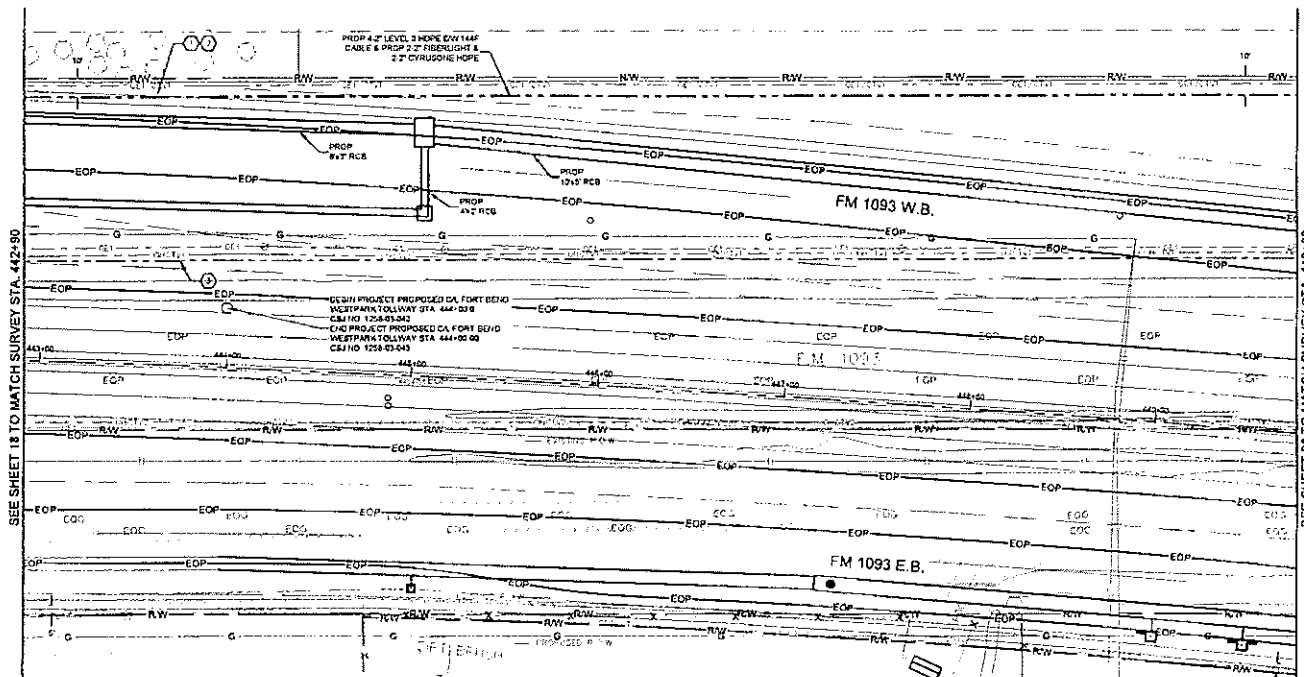

SEE SHEET 18 TO MATCH SURVEY STA. 442+90

SEE SHEET 20 TO MATCH SURVEY STA. 449+80

Page Name: QTY - Materials

Unit Code & Description	Units	Quantity	Material Quality
MAT.00150 - CONDUIT 3" HOPE SDR 9	FT	650	

Page Name: QTY - Work Performed

Unit Code & Description	Units	Quantity	Material Quality
UGB.00023 0 - TRENCH GREATER THAN 1500' TRENCH 48" MINIMUM COVER	FT	650	
UGB.00140 0 - PLACE 1" HOPE CONDUITS IN OPEN TRENCH UP TO 2"	FT	650	
UGB.00250 0 - PLACE UP TO 231 COUNT FOC IN CONDUIT UP TO 1500'	FT	650	
UGB.01060 0 - REMOVE AND DISPOSE OF 1-1.447 CABLE	FT	650	
UGB.00150 0 - PLACE ADDITIONAL HOPE IN OPEN TRENCH CONDUIT UP TO 2"	FT	4820	

UNDERGROUND UTILITIES HAVE BEEN PLOTTED FROM AVAILABLE RECORDS AND FIELD OBSERVATIONS BUT ARE NOT NECESSARILY EXACT. IT IS THE CONTRACTOR'S RESPONSIBILITY TO FIELD LOCATE ALL UNDERGROUND OBSTRUCTIONS AND UTILITIES PRIOR TO CONSTRUCTION. COMPLETE REPAIR OF ANY AND ALL DAMAGES INCURRED SHALL BE AT THE EXPENSE OF THE CONTRACTOR.



CALL BEFORE YOU DIG
1-800-545-6000
48 HOURS NOTICE REQUIRED

HOUSTON, TX
FORT BEND COUNTY



CONSTRUCTION NOTES

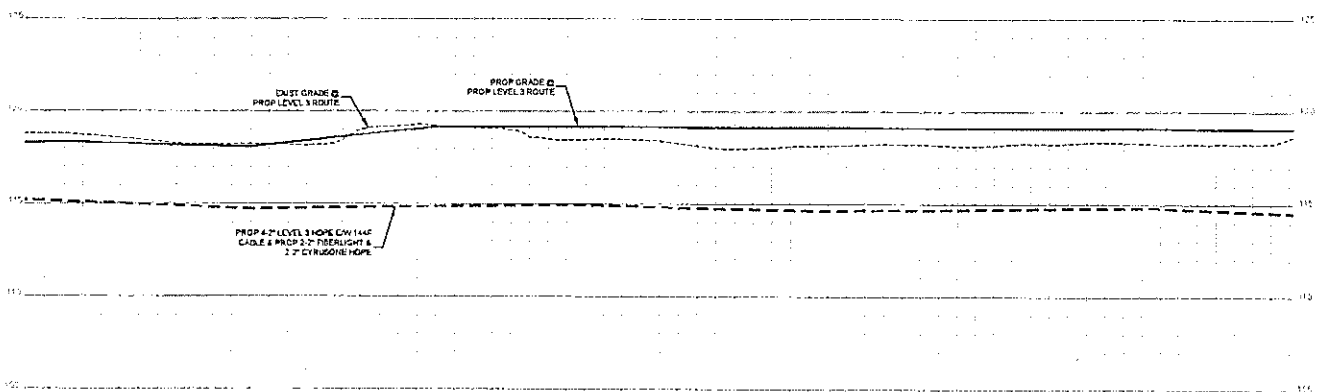

- CONTRACTOR NOTE
CONTRACTOR MUST SUPPLY
ALL HOPE CONFIGURATIONS
NOTED BELOW
- 8\"/>
 - 4\"/>
 - BLACK W/ PURPLE STRIPE
 - BLACK W/ ORANGE STRIPE
 - BLACK W/ GREEN STRIPE
 - BLACK W/ BROWN STRIPE
 - 2\"/>
 - BLACK W/ RED STRIPE
 - BLACK W/ BLUE STRIPE
 - 2\"/>
 - BLACK W/ WHITE STRIPE
 - BLACK W/ GREY STRIPE

NO	DATE	BY	DESCRIPTION
1			
2-3-18		AS-BUILT	
11-13-18		CONTRACTOR	
		DATE/TIME	PERSONNEL

Level(3)
LEVEL 3 ENGINEERING

LEVEL 3 ENGINEER
KEITH HALL
ENGINEERING FIRM
GOLDEN FIELD SERVICES
PROJECT NUMBER
LOCATION: FM 1533 WESTPARK
EXTENSION - HOUSTON, TX
DRAWN/NOTED:

SCALE: VERT 1\"/>

SHEET 18A OF 31
COPYRIGHT RESERVED

UNDERGROUND UTILITIES HAVE BEEN PLOTTED FROM AVAILABLE RECORDS AND FIELD OBSERVATIONS BUT ARE NOT NECESSARILY EXACT. IT IS THE CONTRACTOR'S RESPONSIBILITY TO FIELD LOCATE ALL UNDERGROUND OBSTRUCTIONS AND UTILITIES PRIOR TO CONSTRUCTION. COMPLETE REPAIR OF ANY AND ALL DAMAGES INCURRED SHALL BE AT THE EXPENSE OF THE CONTRACTOR.



CALL BEFORE YOU DIG
1-800-545-6000
48 HOURS NOTICE REQUIRED

HOUSTON, TX
FORT BEND COUNTY

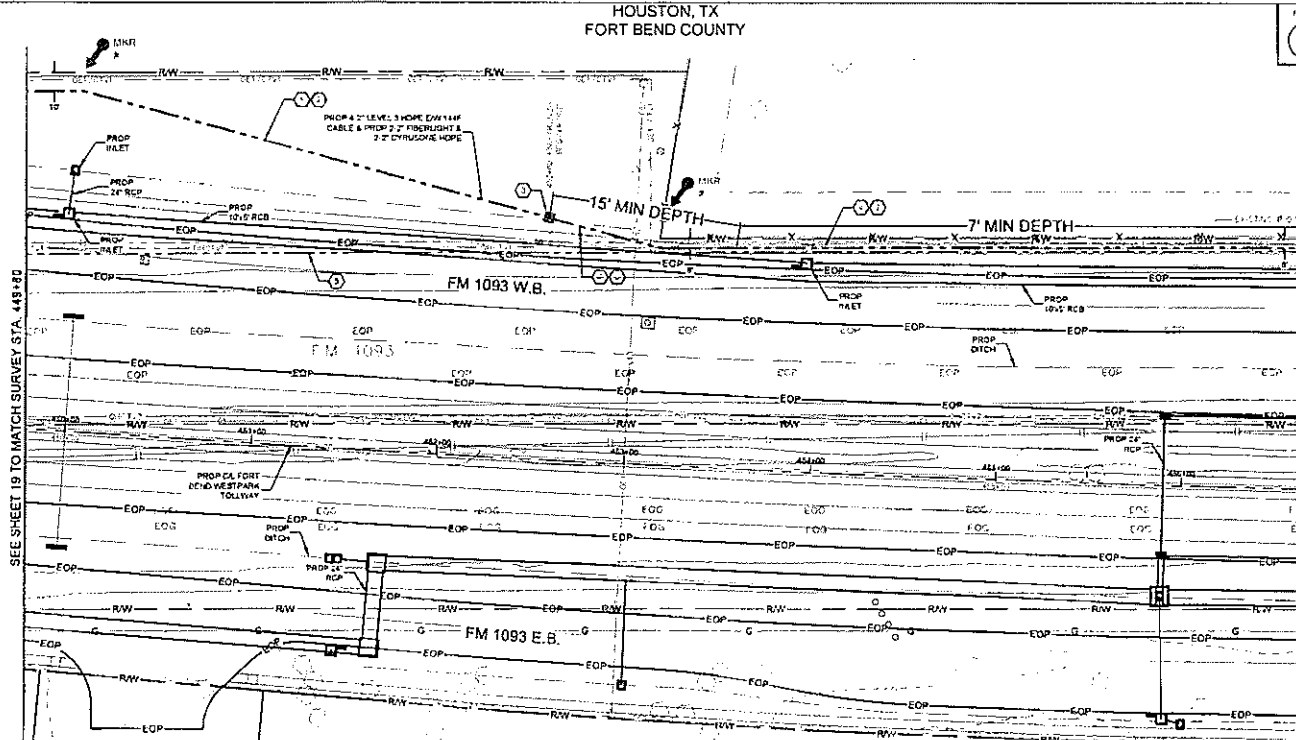

SEE SHEET 19 TO MATCH SURVEY STA. 448+80

SEE SHEET 21 TO MATCH SURVEY STA. 456+60

CONSTRUCTION NOTES

1. CONDUIT OTHER LEVELS
CONDUIT LOWER: 300'
CONDUIT CITY: 1
CONDUIT 200' 2'
CONDUIT TYPE: HDPE
NOTE: MIN. 8"-7" HOPE
2. CABLE OTHER LEVELS
CABLE OTHER LEVELS
CABLE LENGTH: 887
3. PROPOSED HOPE
4. CONDUIT OTHER LEVELS
CONDUIT LENGTH: 400'
CONDUIT CITY: 8
CONDUIT TYPE: HDPE
NOTE: MIN. 8"-7" HOPE
5. CABLE OTHER LEVELS
CABLE OTHER LEVELS
CABLE LENGTH: 647'
NOTE: MIN. 8"-7" HOPE

CONTRACTOR NOTE
CONTRACTOR MUST SUPPLY
ALL HOPE CONDUITS AS
NOTED BELOW

- 8" HOPE CONFIGURATION
- 4" (LEVEL)
 - BLACK W/PURPLE STRIPE
 - BLACK W/ORANGE STRIPE
 - BLACK W/RED STRIPE
 - BLACK W/BROWN STRIPE
 - 2" FIBERGLASS
 - BLACK W/RED STRIPE
 - BLACK W/BLUE STRIPE
 - 2" CYRUSKIC
 - BLACK W/WHITE STRIPE
 - BLACK W/GRY STRIPE

Unit Code & Description	Units	ESTIMATED QUANTITY	ACTUAL QUANTITY
MAT-20150 - CONDUIT 8" HOPE SDR 9	FT	250	
MAT-20250 - WARNING TAPS AND/OR MARKERS	EA	2	

Unit Code & Description	Units	ESTIMATED QUANTITY	ACTUAL QUANTITY
UGB-30050-S - TRENCH GREATER THAN 1500' TRENCH 48" MINIMUM COVER	FT	260	
UGB-30140-S - PLACE 1" HOPE CONDUITS IN OPEN TRENCH UP TO 2"	FT	250	
UGB-30230-S - DIRECTIONAL BORE GREATER THAN 1500' 1 HOPE CONDUIT UP TO 2"	FT	400	
UGB-30300-S - PLACE UP TO 283 CONDUIT FOC IN CONDUIT UP TO 1500'	FT	650	
UGB-31040-S - EXCAVATE SMALL PIT 6"X4'X3'	EA	1	
UGD-31050-S - REMOVE AND DISPOSE OF 1-1/4" CABLE	FT	650	
UGS-31050-S - PLACE LOCATE MARKER POST	EA	2	
UGB-30150-S - PLACE ADDITIONAL HOPE BY OPEN TRENCH CONDUIT UP TO 2"	FT	1,950	
UGB-30700-S - DIR. HOPE GREATER THAN 1500' ADDITIONAL CONDUIT UP TO 2"	FT	2,850	

UNDERGROUND UTILITIES HAVE BEEN PLOTTED FROM AVAILABLE RECORDS AND FIELD OBSERVATIONS BUT ARE NOT NECESSARILY EXACT. IT IS THE CONTRACTOR'S RESPONSIBILITY TO FIELD LOCATE ALL UNDERGROUND OBSTRUCTIONS AND UTILITIES PRIOR TO CONSTRUCTION. COMPLETE REPAIR OF ANY AND ALL DAMAGES INCURRED SHALL BE AT THE EXPENSE OF THE CONTRACTOR.



CALL BEFORE YOU DIG
1-800-545-6009
48 HOURS NOTICE REQUIRED

Level(3)
LEVEL ENGINEER
KEITH HALL
REGISTERED PROFESSIONAL ENGINEER
LOCATION: FM 1093 WESTPARK EXTENSION, HOUSTON, TX
DRAWN BY: JMC
SCALE: HORIZ. 1"=40'
SHEET: 20 OF 31
CONT'DENTIAL/RESERVED

HOUSTON, TX
FORT BEND COUNTY



CONSTRUCTION NOTES

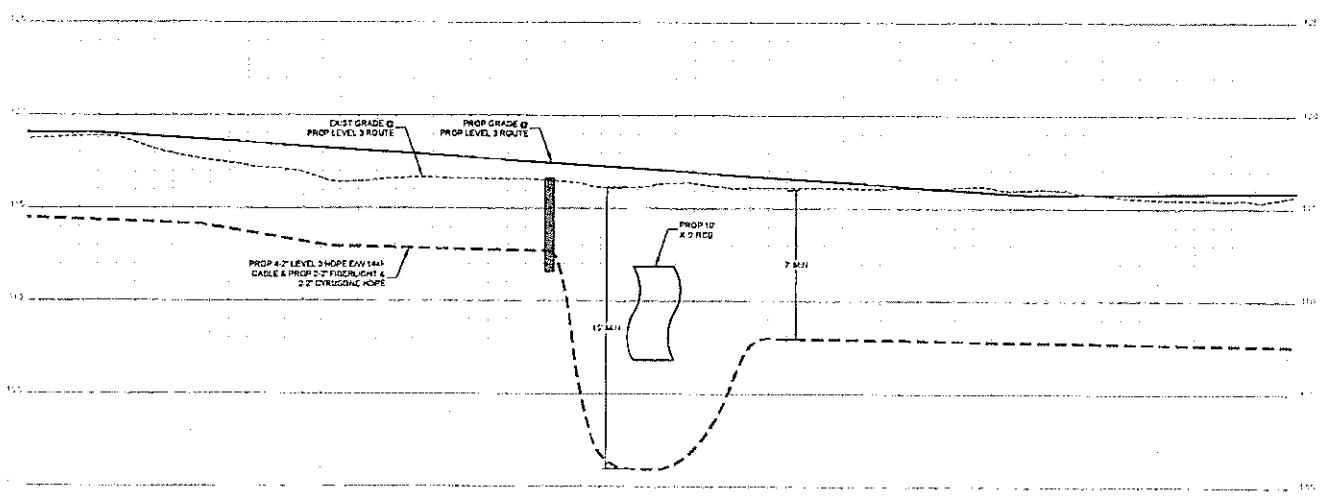

- CONTRACTOR NOTE
CONTRACTOR MUST SUPPLY
ALL HOPE CONDITIONS AS
NOTED BELOW
- 8\"/>
 - 4\"/>
 - BLACK W/ PURPLE STRIPE
 - BLACK W/ ORANGE STRIPE
 - BLACK W/ GREEN STRIPE
 - BLACK W/ BROWN STRIPE
 - 2\"/>
 - BLACK W/ RED STRIPE
 - BLACK W/ BLUE STRIPE
 - 3\"/>
 - BLACK W/ WHITE STRIPE
 - BLACK W/ GREY STRIPE

UNDERGROUND UTILITIES HAVE BEEN PLOTTED FROM AVAILABLE RECORDS AND
FIELD OBSERVATIONS BUT ARE NOT NECESSARILY EXACT. IT IS THE CONTRACTOR'S
RESPONSIBILITY TO FIELD LOCATE ALL UNDERGROUND DISRUPTIONS AND
UTILITIES PRIOR TO CONSTRUCTION. COMPLETE REPAIR OF ANY AND ALL
DAMAGES INCURRED SHALL BE AT THE EXPENSE OF THE CONTRACTOR.

CALL BEFORE YOU DIG
1-800-543-6025
48 HOURS NOTICE REQUIRED

NO.	DATE	DESCRIPTION
1		
2		
3		
4		
5		
6		
7		
8		
9		
10		
11		
12		
13		
14		
15		
16		
17		
18		
19		
20		
21		
22		
23		
24		
25		
26		
27		
28		
29		
30		
31		
32		
33		
34		
35		
36		
37		
38		
39		
40		
41		
42		
43		
44		
45		
46		
47		
48		
49		
50		
51		
52		
53		
54		
55		
56		
57		
58		
59		
60		
61		
62		
63		
64		
65		
66		
67		
68		
69		
70		
71		
72		
73		
74		
75		
76		
77		
78		
79		
80		
81		
82		
83		
84		
85		
86		
87		
88		
89		
90		
91		
92		
93		
94		
95		
96		
97		
98		
99		
100		

Level(3)
ENGINEERS

LEVEL 3 ENGINEER
4511H HALL
6140 N. GARDENWAY
DUNWOODY, GA 30328
PROJECT NUMBER
LOCATION: 241033 MS STPANK
EXTENSION - HOUSTON, TX
UNITS: US CUSTOMARY

SCALE: VERT 1"=2'
SHEET 20A OF 31
©2009 LEVEL 3 ENGINEERS

HOUSTON, TX
FORT BEND COUNTY



CONSTRUCTION NOTES

- 1 CONDUIT OWNER LEVELS
CONDUIT LOCATED 180"
CONDUIT SIZE 2"
CONDUIT TYPE: HDPE
NOTE: BORE 8-1/2" HOPE
- 2 CABLE FIBERS: 144F
CABLE OWNER: LEVELS
CABLE LENGTH: 180'
- 3 CABLE FIBERS: 144F
CABLE OWNER: LEVELS
CABLE LENGTH: 180'
NOTE: BORE 8-1/2" HOPE

- CONSTRUCTION NOTE
CONTRACTOR MUST SUPPLY
ALL HOPE CONDUITS AS
NOTED BELOW
- 8-1/2" HOPE CONFIGURATION:
- 4" LEVELS
 - BLACK W/ PURPLE STRIPE
 - BLACK W/ ORANGE STRIPE
 - BLACK W/ GREEN STRIPE
 - BLACK W/ BROWN STRIPE
- 2" FIBERLIGHT
- BLACK W/ RED STRIPE
 - BLACK W/ BLUE STRIPE
 - 1" C FIBERGLASS
 - BLACK W/ WHITE STRIPE
 - BLACK W/ GREY STRIPE

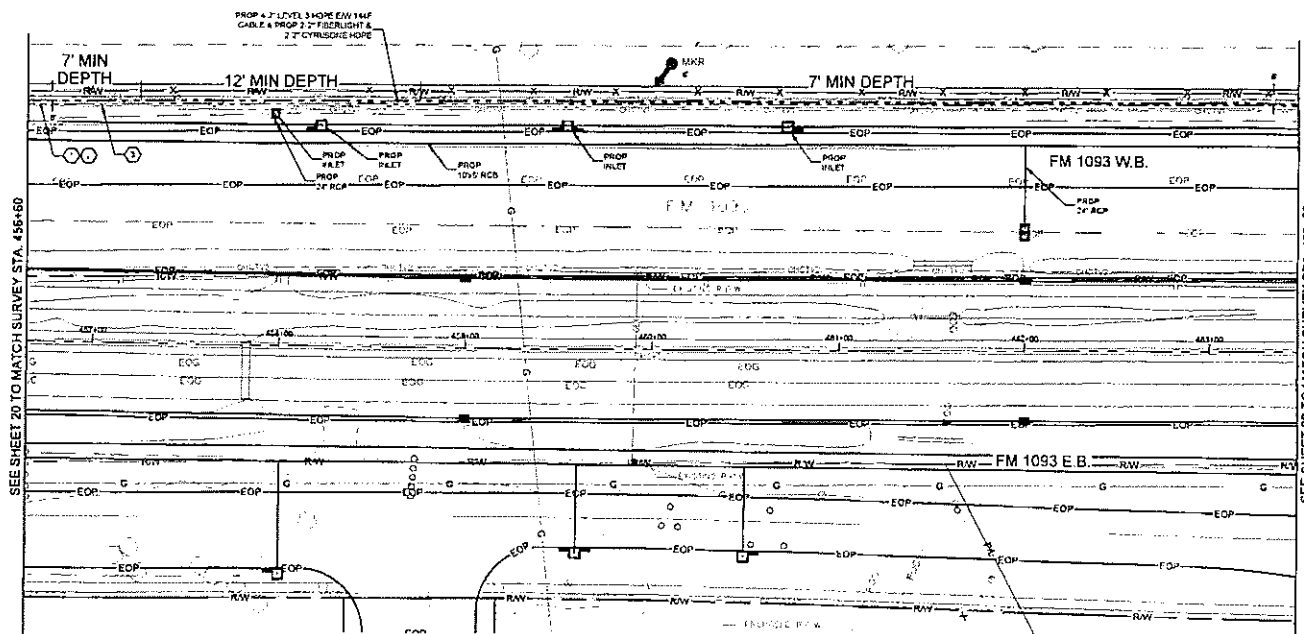

SEE SHEET 20 TO MATCH SURVEY STA. 458+50

SEE SHEET 22 TO MATCH SURVEY STA. 463+50

Page Name Off - Materials			
Unit Code & Description	Units	Estimated Quantity	Actual Quantity
MAT-20150 - CONDUIT 8 2" HOPE SDR 9	FT	670	
MAT-32030 - WARNING TAGS AND/OR MARKERS	EA	1	

Page Name Off - Work Performed			
Unit Code & Description	Units	Estimated Quantity	Actual Quantity
UDS-30650-S - DIRECTIONAL BORE GREATER THAN 1500' 1 HOPE CONDUIT UP TO 2"	FT	670	
UDS-30200-S - PLACE UP TO 200 CONDUIT POC BY CONDUIT LP TO 1500'	FT	670	
UDS-31600-S - REMOVE AND DISPOSE OF 1 144F CABLE	FT	670	
UDS-31200-S - PLACE LOCATE MARKER POST	EA	1	
UDS-30700-S - DIR BORE GREATER THAN 1500' ADDITIONAL CONDUIT LP TO 2"	FT	4,830	



UNDERGROUND UTILITIES HAVE BEEN PLOTTED FROM AVAILABLE RECORDS AND FIELD OBSERVATIONS BUT ARE NOT NECESSARILY EXACT. IT IS THE CONTRACTOR'S RESPONSIBILITY TO FIELD LOCATE ALL UNDERGROUND OBSTRUCTIONS AND UTILITIES PRIOR TO CONSTRUCTION. COMPLETE REPAIR OF ANY AND ALL DAMAGES INCURRED SHALL BE AT THE EXPENSE OF THE CONTRACTOR.

Level(3)
LEVEL 3 MARKER
METHODS
ENGINEERING FIRM
GOLDENFIELD SERVICES
PROJECT NUMBER
LOCATION: FM 1093 WESTPARK
EXTENSION - HOUSTON, TX
DRAWING DATE

SCALE	HOR 1"=50'
SHEET	21 OF 31
DATE	08/14/2024

HOUSTON, TX
FORT BEND COUNTY



CONSTRUCTION NOTES

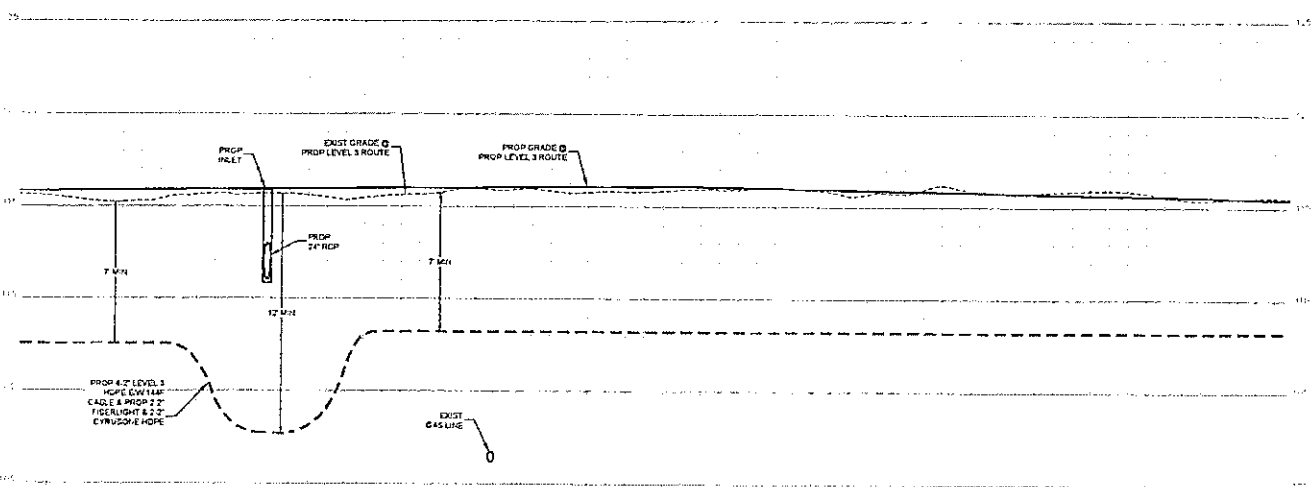

- CONTRACTOR MUST
CONTRACTOR MUST SUPPLY
ALL HOPE CONDUITS AS
LISTED BELOW
- 6.2" HOPE CONDUITATION
 - 4.2" LEVEL 3
 - BLACK W/ PURPLE STRIPE
 - BLACK W/ ORANGE STRIPE
 - BLACK W/ GREEN STRIPE
 - BLACK W/ BROWN STRIPE
 - 2.2" FIBERGLITE
 - BLACK W/ RED STRIPE
 - BLACK W/ BLUE STRIPE
 - 2.2" CYRUSONE
 - BLACK W/ WHITE STRIPE
 - BLACK W/ GREY STRIPE

1		
2		
3		
NO.	REV.	END REASON
1-2-16		AS-BUILT
11/14/13		ISSUED
		DRAWING
		DATE



LEVEL 3 ENGINEER
KEITH HALL
REGISTERED PROFESSIONAL ENGINEER
NO. 60867
PROJECT NUMBER
LOCATION: FM 1027 WE STAFF
EXTENSION, HOUSTON, TX
DRAWN BY: [Name]

SCALE: VERT 1"=4'
SHEET 21A OF 31
© 2013 LEVEL 3 ENGINEERS

UNDERGROUND UTILITIES HAVE BEEN PLOTTED FROM AVAILABLE RECORDS AND FIELD OBSERVATION BUT ARE NOT NECESSARILY EXACT. IT IS THE CONTRACTOR'S RESPONSIBILITY TO FIELD LOCATE ALL UNDERGROUND OBSTRUCTIONS AND UTILITIES PRIOR TO CONSTRUCTION. COMPLETE REPAIR OF ANY AND ALL DAMAGES INCURRED SHALL BE AT THE EXPENSE OF THE CONTRACTOR.



CALL BEFORE YOU DIG
1-800-541-8005
48 HOURS NOTICE REQUIRED

HOUSTON, TX
FORT BEND COUNTY



CONSTRUCTION NOTES

1. COEXIST OWNER LEVELS
COEXIST LEVELS BY
COEXIST CRT'S
COEXIST SIZE 2"
COEXIST TYPE HOPE
MIN. DEPTH 1'-2" HOPE
2. LEVEL HANDLE
CODE 107 1-1/4" H.H.
3. PROPOSED HOPE'S
4. COEXIST OWNER LEVELS
COEXIST LEVELS 100'
COEXIST CRT'S
COEXIST SIZE 2"
COEXIST TYPE HOPE
MIN. DEPTH 1'-2" HOPE
5. CABLE TRENCH 144"
CABLE OWNER LEVELS
CABLE LENGTH 70'
6. CABLE TRENCH 144"
CABLE OWNER LEVELS
CABLE LENGTH 144"
MIN. DEPTH 1'-2" HOPE
7. FREIGHT VEHICLE
8. CRANE VEHICLE

- CONTRACTOR NOTE
CONTRACTOR MUST SUPPLY
ALL HOPE CONDUITS AS
NOTED BELOW
- 8.2" HOPE CONFIGURATION
4" LEVEL(S)
 - BLACK W/ PURPLE STRIPE
 - BLACK W/ ORANGE STRIPE
 - BLACK W/ GREEN STRIPE
 - BLACK W/ BROWN STRIPE
 - 2" FIBERGLASS
BLACK W/ RED STRIPE
 - BLACK W/ BLUE STRIPE
 - 3" CYRUSHOPE
BLACK W/ WHITE STRIPE
 - BLACK W/ GREY STRIPE

SEE SHEET 21 TO MATCH SURVEY STA. 463+50

SEE SHEET 23 TO MATCH SURVEY STA. 470+30

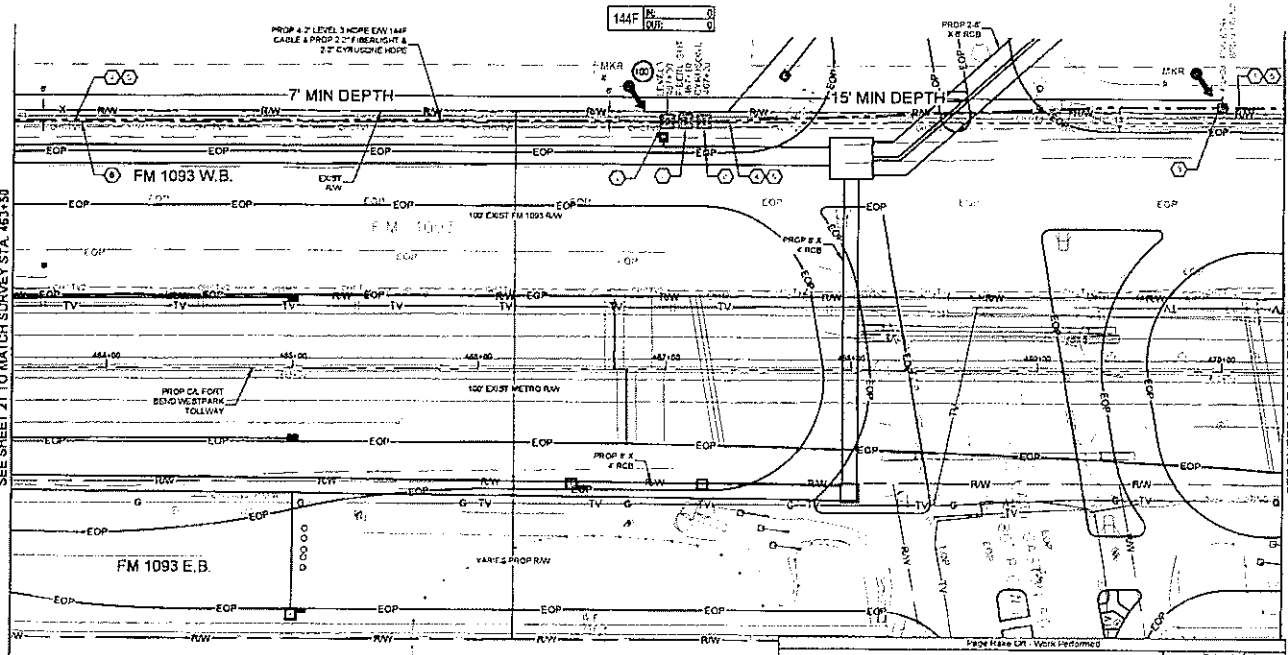

Unit Code & Description	Units	Estimated Quantity	Actual Quantity
MAT-00150 - CONDUIT 8" HOPE SDR 9	FT	650	
MAT-00270 - TIER 15 30"x45"90" - WITH KNOCK-OUTS AND RACKING - INCLUDING COVER	EA	3	
MAT-81090 - WARNING TAGS AND/OR MARKERS	EA	2	

Unit Code & Description	Units	Estimated Quantity	Actual Quantity
UGB-30050-S - TRENCH GREATER THAN 1500' TRENCH 48" MINIMUM COVER	FT	30	
UGB-30140-S - PLACE 1 HOPE CONDUITS IN OPEN TRENCH UP TO 2"	FT	30	
UGB-30020-S - DIRECTIONAL BORE GREATER THAN 1100' 1 HOPE CONDUIT UP TO 2"	FT	610	
UGB-30920-S - PLACE UP TO 228 CONDUIT FCC BY CONDUIT UP TO 1500' (103' IN COLL)	FT	780	
UGB-31270-S - PLACE NEW 30"x45"90" HOPE CONCRETE HANDHOLE	EA	3	
UGB-31640-S - EXCAVATE SMALL PIT 8'x4'x2'	EA	1	
UGB-31520-S - REMOVE AND DISPOSE OF 1-144" CABLE	FT	635	
UGB-31520-S - PLACE ADDITIONAL HOPE IN OPEN TRENCH CONDUIT UP TO 2"	FT	210	
UGB-30700-S - DIR BORE GREATER THAN 1500' ADDITIONAL CONDUIT UP TO 2"	FT	4550	



CALL BEFORE YOU DIG
1-800-4-A-DIG
48 HOURS NOTICE REQUIRED

UNDERGROUND UTILITIES HAVE BEEN PLOTTED FROM AVAILABLE RECORDS AND FIELD OBSERVATIONS BUT ARE NOT NECESSARILY EXACT. IT IS THE CONTRACTOR'S RESPONSIBILITY TO FIELD LOCATE ALL UNDERGROUND OBSTRUCTIONS AND UTILITIES PRIOR TO CONSTRUCTION. COMPLETE REPAIR OF ANY AND ALL DAMAGES INCURRED SHALL BE AT THE EXPENSE OF THE CONTRACTOR.

Level(3)
LEVEL 3 ENGINEER
10514 HALL
ENGINEERING FIRM
200 DENHAM RD
HOUSTON, TX 77057
PROJECT NUMBER:
LOCATION: FM 1093 WESTPARK
EXTENSION - HOUSTON TX
DRAWING TITLE:

SCALE: HGR 1"=20'
SHEET: 22 OF 31
CONTRACT/PROJECT NUMBER:

HOUSTON, TX
FORT BEND COUNTY



CONSTRUCTION NOTES

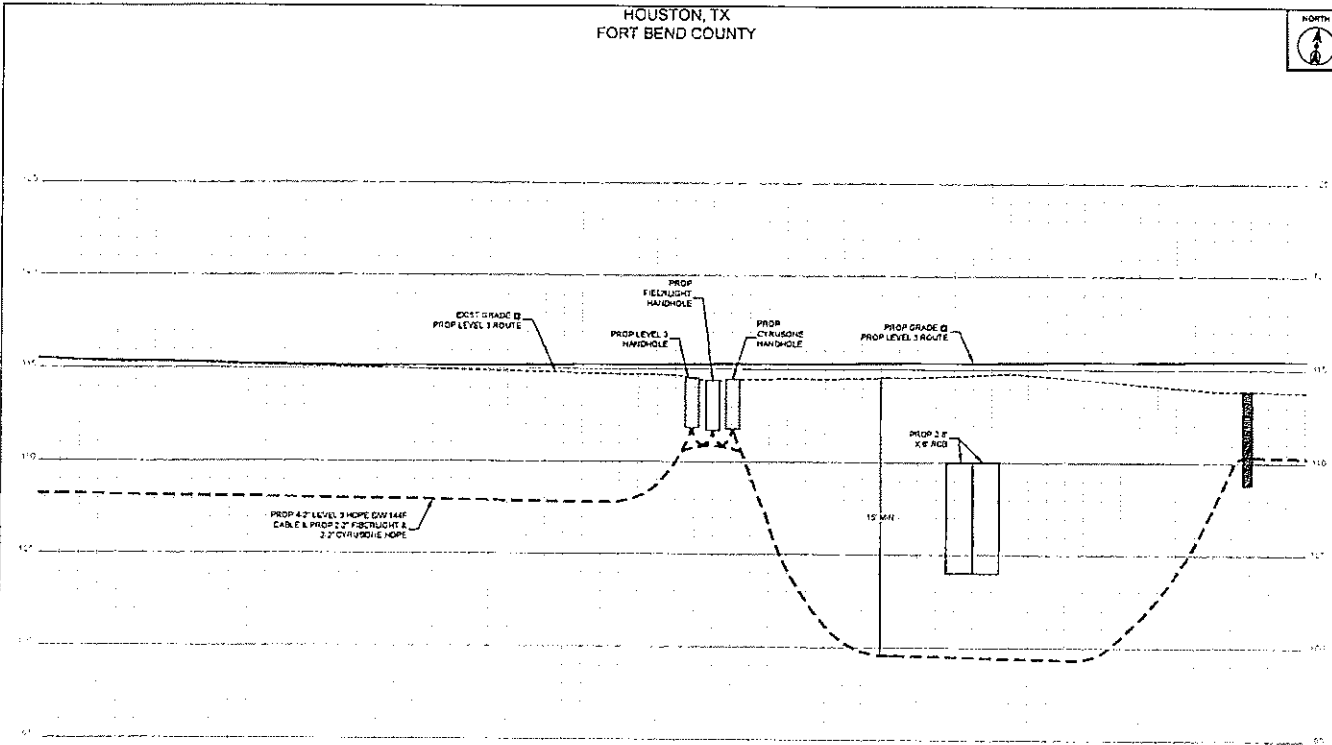

CONTRACTOR NOTE
CONTRACTOR MUST VERIFY
ALL HOPE COORDINATES AS
NOTED BELOW.

- 6\"/>

1		
2		
NO.	DATE	BY
1	11-13-13	SP/ML
2	11-13-13	SP/ML

Level(3)
LEVEL ENGINEERING

LEVEL ENGINEER
KATH HALL
ENGINEERING FIRM
LOCAL FIELD SERVICES
PROJECT MANAGER
LOCATION: FM 1933 WESTPARK
EXTENSION, HOUSTON, TX
DATE: 11/13/13

SCALE: VERT. 1"=1'
SHEET 22A OF 31
LAWRENCE/PROPRIETARY



CALL BEFORE YOU DIG
1-800-4-A-DIG
48 HOURS NOTICE REQUIRED

UNDERGROUND UTILITIES HAVE BEEN PLOTTED FROM AVAILABLE RECORDS AND
FIELD OBSERVATIONS BUT ARE NOT NECESSARILY EXACT. IT IS THE CONTRACTOR'S
RESPONSIBILITY TO FIELD LOCATE ALL UNDERGROUND OBSTRUCTIONS AND
UTILITIES PRIOR TO CONSTRUCTION. COMPLETE REPAIR OF ANY AND ALL
DAMAGES INCURRED SHALL BE AT THE EXPENSE OF THE CONTRACTOR.

HOUSTON, TX
FORT BEND COUNTY

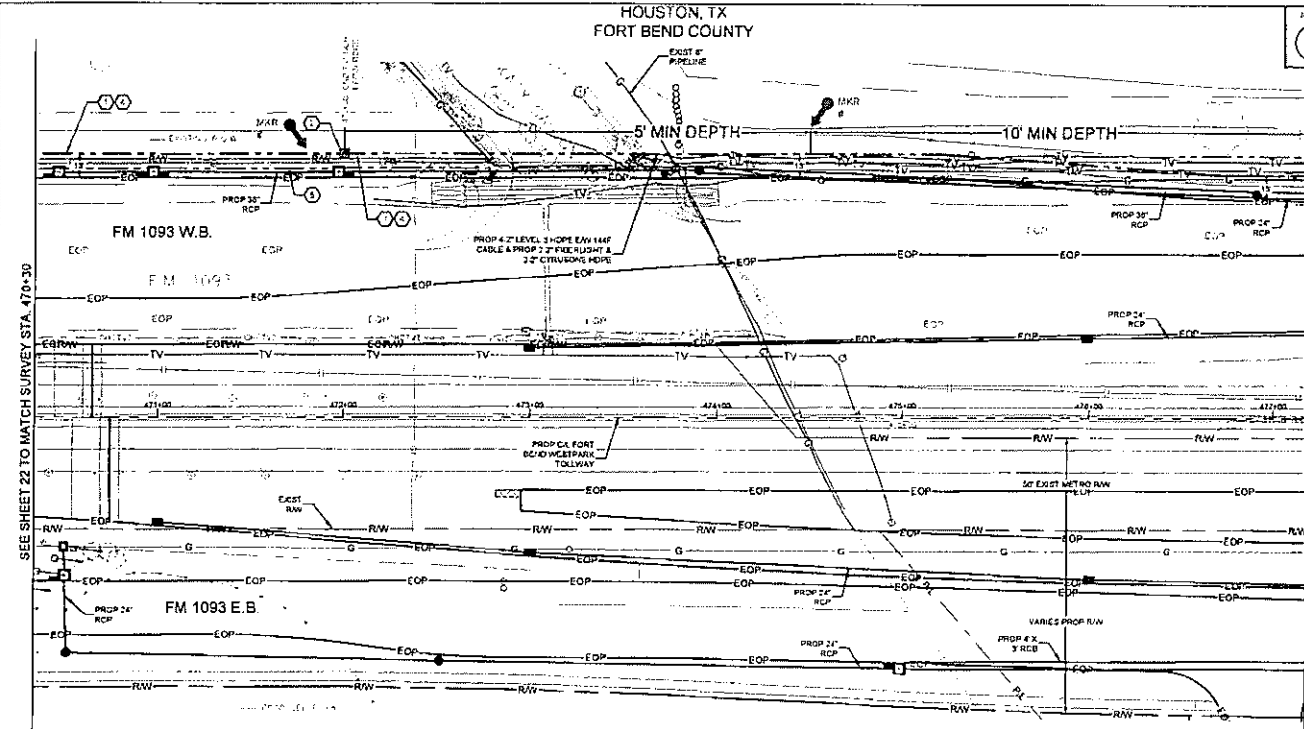

- CONSTRUCTION NOTES**
- CONDUIT OWNER LOGS
CONDUIT LOCUS 117
CONDUIT 67-8
CONDUIT 67-9
CONDUIT TYPE: HOPE
NOTE: BORE 8-2" HOPE
 - PROPOSED MARKER
 - CONDUIT OWNER LOGS
CONDUIT LOCUS 107
CONDUIT 67-3
CONDUIT TYPE: HOPE
NOTE: BORE 8-2" HOPE
 - CABLE NUMBER: 1447
CABLE OWNER: LEVEL
CABLE LOCUS: 107
 - CABLE NUMBER: 1447
CABLE OWNER: LEVEL
CABLE LOCUS: 107
NOTE: REMOVE 1447 CABLE

- CONTRACTOR NOTE**
CONTRACTOR MUST SUPPLY
ALL HOPE CONDUITS AS
NOTED BELOW
- 8-2" HOPE CONFIGURATION:
8-2" (LEVEL)
- BLACK W/ PURPLE STRIPE
 - BLACK W/ ORANGE STRIPE
 - BLACK W/ GREEN STRIPE
 - BLACK W/ BROWN STRIPE
- 3-2" FIBERGLASS
BLACK W/ RED STRIPE
BLACK W/ BLUE STRIPE
3-2" CRUSHED
BLACK W/ WHITE STRIPE
BLACK W/ GRAY STRIPE

SEE SHEET 22 TO MATCH SURVEY STA. 470+30

SEE SHEET 24 TO MATCH SURVEY STA. 477+20

Page Name: Ch - Materials

Unit Code & Description	Units	ESTIMATED QUANTITY	ASBUILT QUANTITY
MAT-50150 - CONDUIT 8-2" HOPE SDR 4	FT	600	
MAT-92000 - WARNING TAGS AND/OR MARKERS	EA	2	

Page Name: Ch - Work Performed

Unit Code & Description	Units	ESTIMATED QUANTITY	ASBUILT QUANTITY
UGS-30160-S - TRENCH GREATER THAN 1500' TRENCH 48" MINIMUM COVER	FT	370	
UGS-30140-S - PLACE 1" HOPE CONDUITS IN OPEN TRENCH UP TO 2"	FT	370	
UGS-30120-S - DIRECTIONAL BORE GREATER THAN 1500' 1 HOPE CONDUIT UP TO 2"	FT	520	
UGS-30100-S - PLACE UP TO 288 COUNT FOC IN CONDUIT UP TO 1500'	FT	600	
UGS-3140-S - EXCAVATE SMALL PIT 6'X4'X0'	EA	1	
UGS-3120-S - REMOVE AND DISPOSE OF 1-1447 CABLE	FT	630	
UGS-31100-S - PLACE LOCATE MARKER POST	EA	2	
UGS-30150-S - PLACE ADDITIONAL HOPE IN OPEN TRENCH CONDUIT UP TO 2"	FT	1 100	
UGS-30700-S - D-R BORE GREATER THAN 1500' ADDITIONAL CONDUIT UP TO 2"	FT	3 640	

UNDERGROUND UTILITIES HAVE BEEN PLOTTED FROM AVAILABLE RECORDS AND FIELD OBSERVATIONS BUT ARE NOT NECESSARILY EXACT. IT IS THE CONTRACTOR'S RESPONSIBILITY TO FIELD LOCATE ALL UNDERGROUND OBSTRUCTIONS AND UTILITIES PRIOR TO CONSTRUCTION. COMPLETE REPAIR OF ANY AND ALL DAMAGES INCURRED SHALL BE AT THE EXPENSE OF THE CONTRACTOR.



Level(3)
CONSTRUCTION

LEVEL 3 ENGINEER
KATH HALL
ENGINEERING FIRM
CONCRETE FIELD SERVICES
PROJECT NUMBER
LOCATION: FM 1093 WESTPARK
EXTENSION HOUSTON, TX
DRAWN: TCM

SCALE: HQR 1"=50'
SHEET: 23 OF 31
DATE: 08/14/2018

HOUSTON, TX
FORT BEND COUNTY



CONSTRUCTION NOTES

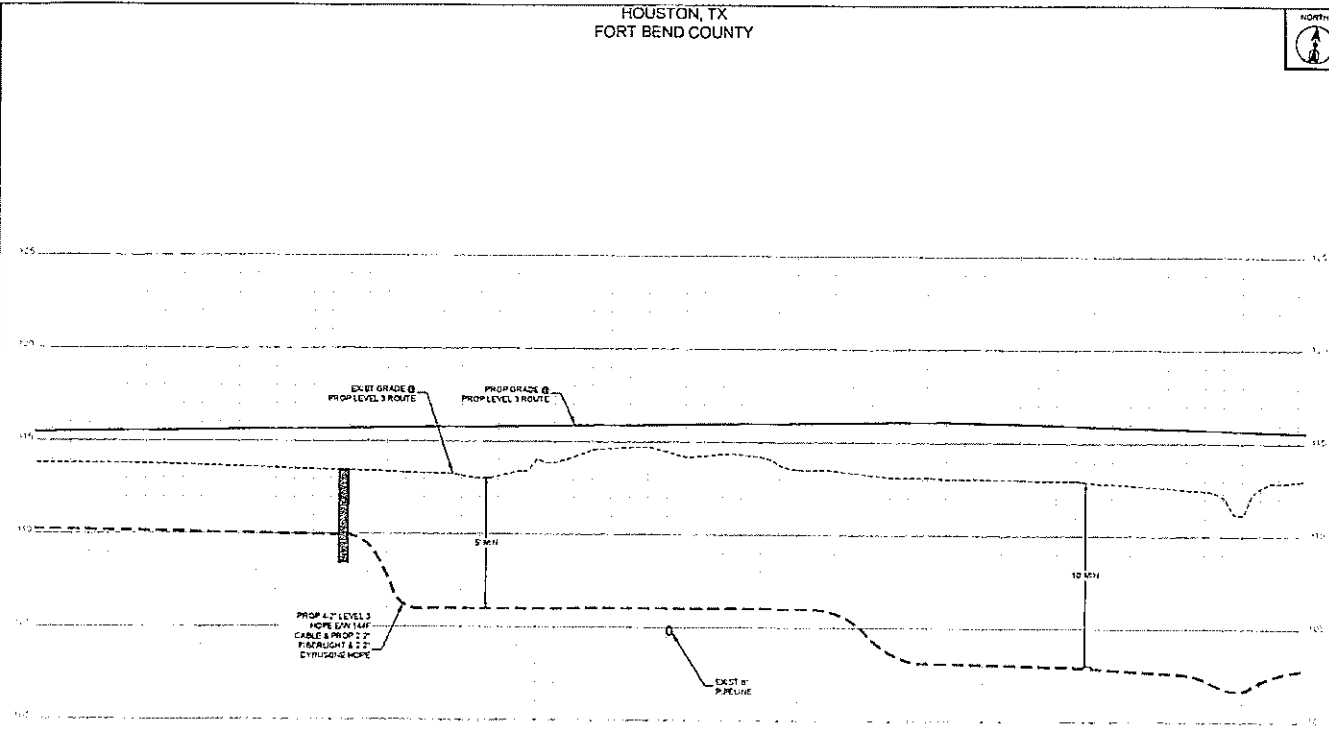

- CONTRACTOR NOTE
CONTRACTOR MUST SUPPLY
ALL HOPE CONFIGS AS
NOTED BELOW.
- 8" HOPE CONFIGURATION
- 4" LEVEL 1
 - BLACK W/ PURPLE STRIPE
 - BLACK W/ ORANGE STRIPE
 - BLACK W/ GREEN STRIPE
 - BLACK W/ BROWN STRIPE
- 2" FIBERGLASS
- BLACK W/ RED STRIPE
 - BLACK W/ BLUE STRIPE
- 3" FIBERGLASS
- BLACK W/ WHITE STRIPE
 - BLACK W/ GREY STRIPE

NO.	DATE	REV. REASON
1		
2		
3		

Level(3)
SYNAGIS/STAFFERS

LEVEL 3 ENGINEER
NETH HALL

EIGHTH ZERO FIVE
DODSON FIELD SERVICE

PROJECT NUMBER

LOCATION 1M 603 WESTPARK
LATHROP - HOUSTON TX

DRAWING NUMBER

SCALE VERT 1"=4'

SHEET 23A OF 31

COPYRIGHT PROPRIETARY

UNDERGROUND UTILITIES HAVE BEEN PLOTTED FROM AVAILABLE RECORDS AND FIELD OBSERVATIONS BUT ARE NOT NECESSARILY EXACT. IT IS THE CONTRACTOR'S RESPONSIBILITY TO FIELD LOCATE ALL UNDERGROUND OBSTRUCTIONS AND UTILITIES PRIOR TO CONSTRUCTION. COMPLETE REPAIR OF ANY AND ALL DAMAGES INCURRED SHALL BE AT THE EXPENSE OF THE CONTRACTOR.



CALL BEFORE YOU DIG
1.800.545.4000
48 HOURS NOTICE REQUIRED

HOUSTON, TX
FORT BEND COUNTY



- CONSTRUCTION NOTES**
- 1. 60' DEEP OPEN LEVEL CONDUIT UNDER 100' CONDUIT SIZE 8 CONDUIT SIZE 8 CONDUIT TYPE 80000 TYPE 80000 NOTES: 8-1" HOPE
 - 2. CABLE PRODS. 144" CABLE UNDER LEVEL CABLE UNDER 100'
 - 3. CABLE PRODS. 144" CABLE UNDER LEVEL CABLE UNDER 100' NOTES: 8-1" HOPE

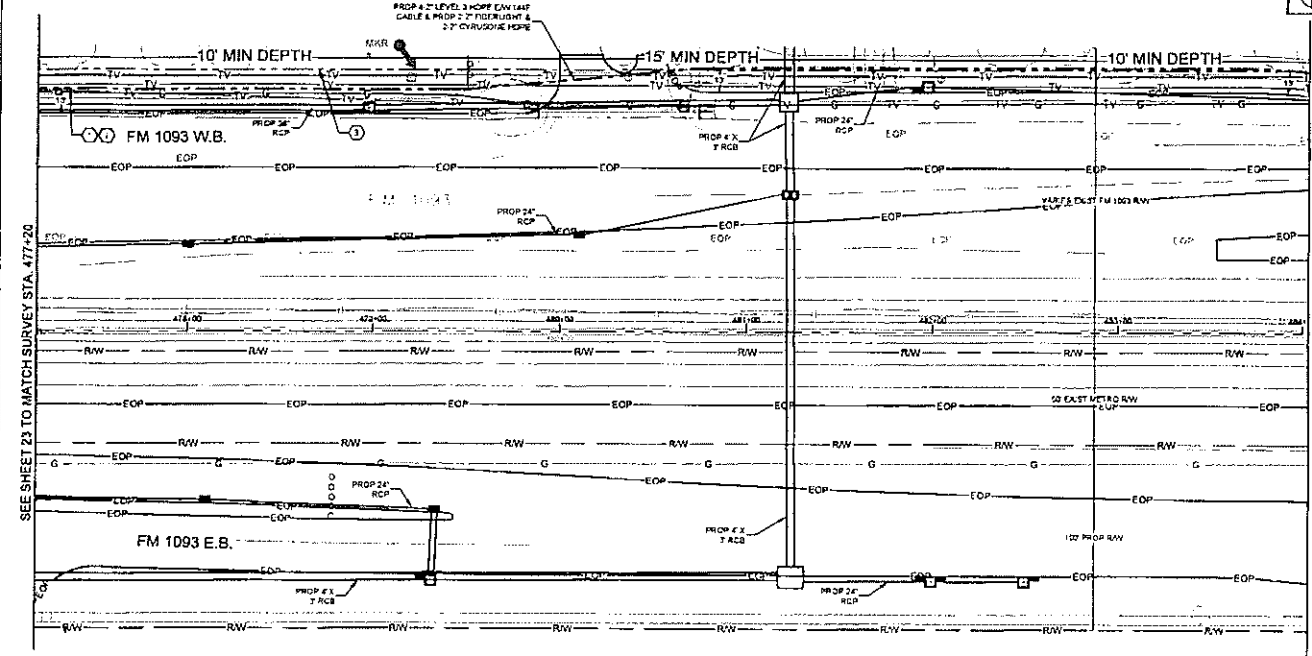

SEE SHEET 23 TO MATCH SURVEY STA. 477+20

SEE SHEET 25 TO MATCH SURVEY STA. 484+00

Page Name	DT	Materials	Units	Estimated Quantity	Actual Quantity
MAT-30110 - CONDUIT 8" HOPE SDR 8			FT	650	
MAT-37200 - WARNING TAGS AND/OR MARKERS			EA	1	

Page Name	DT	Work Performed	Units	Estimated Quantity	Actual Quantity
UGB-30630-S - DIRECTIONAL BORE (GREATER THAN 1500')		1 HOPE CONDUIT UP TO 2"	FT	650	
UGB-30630-S - PLACE UP TO 2" CONDUIT FOR IN CONDUIT UP TO 1500'			FT	650	
UGB-31050-S - REMOVE AND DISPOSE OF 1-144" CABLE			FT	630	
UGB-31920-S - PLACE LOCATE MARKERS PCSD			EA	1	
UGB-30700-S - DR. BORE GREATER THAN 1500' ADDITIONAL CONDUIT UP TO 2"			FT	4,700	

UNDERGROUND UTILITIES HAVE BEEN PLOTTED FROM AVAILABLE RECORDS AND FIELD OBSERVATIONS BUT ARE NOT NECESSARILY EXACT. IT IS THE CONTRACTOR'S RESPONSIBILITY TO FIELD LOCATE ALL UNDERGROUND OBSTRUCTIONS AND UTILITIES PRIOR TO CONSTRUCTION. COMPLETE REPAIR OF ANY AND ALL DAMAGES INCURRED SHALL BE AT THE EXPENSE OF THE CONTRACTOR.



CALL BEFORE YOU DIG
1-800-545-6225
48 HOURS NOTICE REQUIRED

- CONTRACTOR SHALL SUPPLY ALL HOPE CONDUITS AS NOTED BELOW:
- 8" HOPE CONFIGURATION
 - 4" LEVEL(S)
 - BLACK W/ PURPLE STRIPE
 - BLACK W/ ORANGE STRIPE
 - BLACK W/ GREEN STRIPE
 - BLACK W/ RED W/ WHITE STRIPE
 - 3" FIBER OPTIC
 - BLACK W/ RED STRIPE
 - BLACK W/ BLUE STRIPE
 - 3" FIBER OPTIC
 - BLACK W/ WHITE STRIPE
 - BLACK W/ GREY STRIPE

Level (3)
LEVEL 3 ENGINEERING

LEVEL ENGINEER
KEITH HALL

ENGR. REG. NO. 11811-15
ISSUE DATE: 01/15/15

PROJECT NUMBER
LOCATION: FM 1093 WESTPARK EXTENSION, HOUSTON, TX

SCALE: 1"=40'
SHEET: 24 OF 31
DRAWN BY: JAL/PROPRIETARY

HOUSTON, TX
FORT BEND COUNTY



CONSTRUCTION NOTES

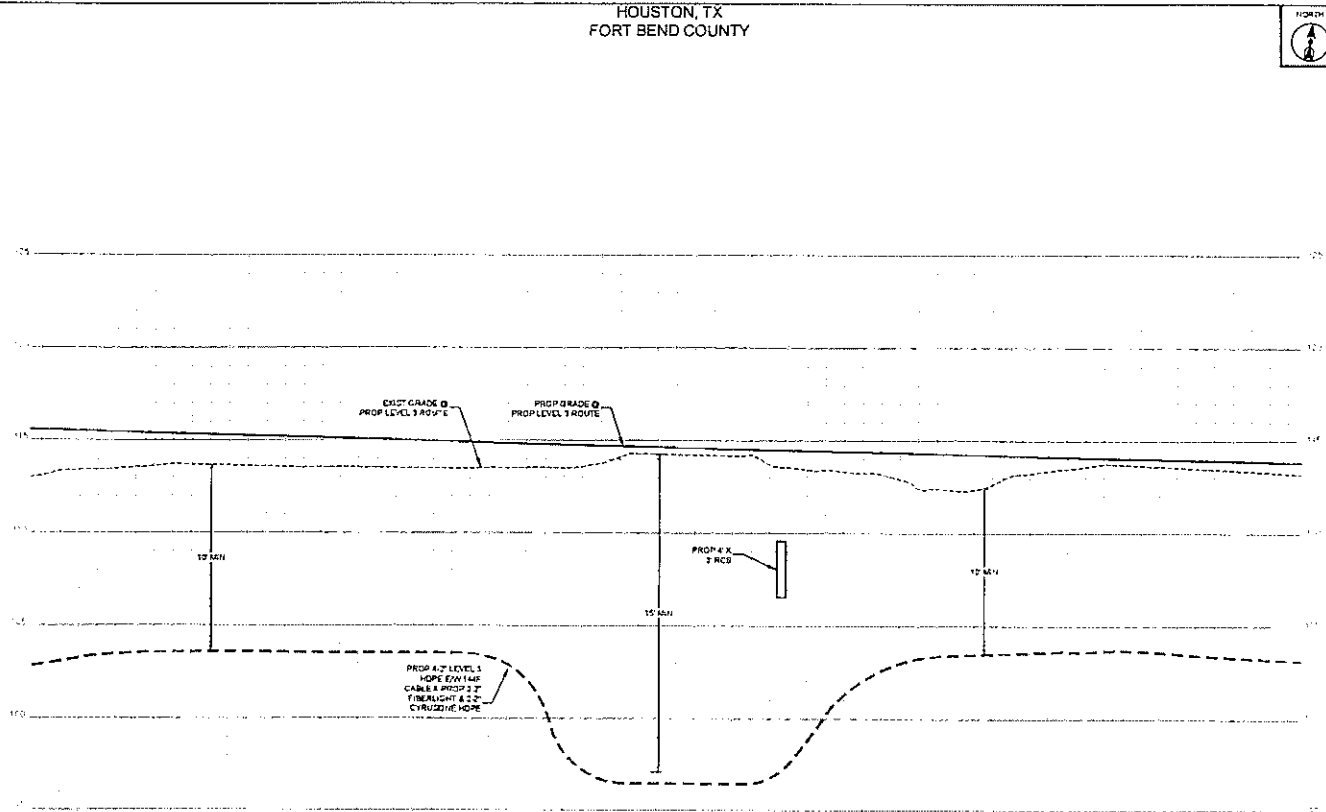

- CONTRACTOR NOTE
CONTRACTOR MUST SUPPLY
ALL HOPE CONDUITS AS
NOTED BELOW.
- 6\"/>
 - BLACK W/ PURPLE STRIPE
 - BLACK W/ ORANGE STRIPE
 - BLACK W/ GREEN STRIPE
 - BLACK W/ BROWN STRIPE

2\"/>
 - BLACK W/ RED STRIPE
 - BLACK W/ BLUE STRIPE
 - BLACK W/ WHITE STRIPE
 - BLACK W/ GREY STRIPE

NO.	DATE	BY	REASON
1			

Level(3)
CONSTRUCTION SERVICES

15015 JACOBSON
HOUSTON, TX 77058

ENGINEERED FROM
CONSTRUCTION SERVICES
PROJECT NUMBER:

LOCATION: FM 1031 WESTPARK
EXTENSION HOUSTON, TX
DATE: 02/20/2018

SCALE: 1/4\"/>

SHEET 24A OF 31

CONFIDENTIAL - PRIVATE

UNDERGROUND UTILITIES HAVE BEEN PLOTTED FROM AVAILABLE RECORDS AND FIELD OBSERVATIONS BUT ARE NOT NECESSARILY EXACT. IT IS THE CONTRACTOR'S RESPONSIBILITY TO FIELD LOCATE ALL UNDERGROUND OBSTRUCTIONS AND UTILITIES PRIOR TO CONSTRUCTION. COMPLETE REPAIR OF ANY AND ALL DAMAGES INCURRED SHALL BE AT THE EXPENSE OF THE CONTRACTOR.



CALL BEFORE YOU DIG
1-800-545-0055
48 HOUR NOTICE REQUIRED

HOUSTON, TX
FORT BEND COUNTY



- CONSTRUCTION NOTES**
1. CONDUIT OWNER LEVELS
CONDUIT LENGTH 1500'
CONDUIT SIZE 8"
CONDUIT TYPE 1" HDPE
NOTE: BORE 8-1/2" HERE
 2. CABLE FEEDS 1147'
CABLE OWNER LEVELS
CABLE LENGTH 1500'
 3. CABLE FEEDS 1147'
CABLE OWNER LEVELS
CABLE LENGTH 1500'
NOTE: REMOVE 1147' CABLE

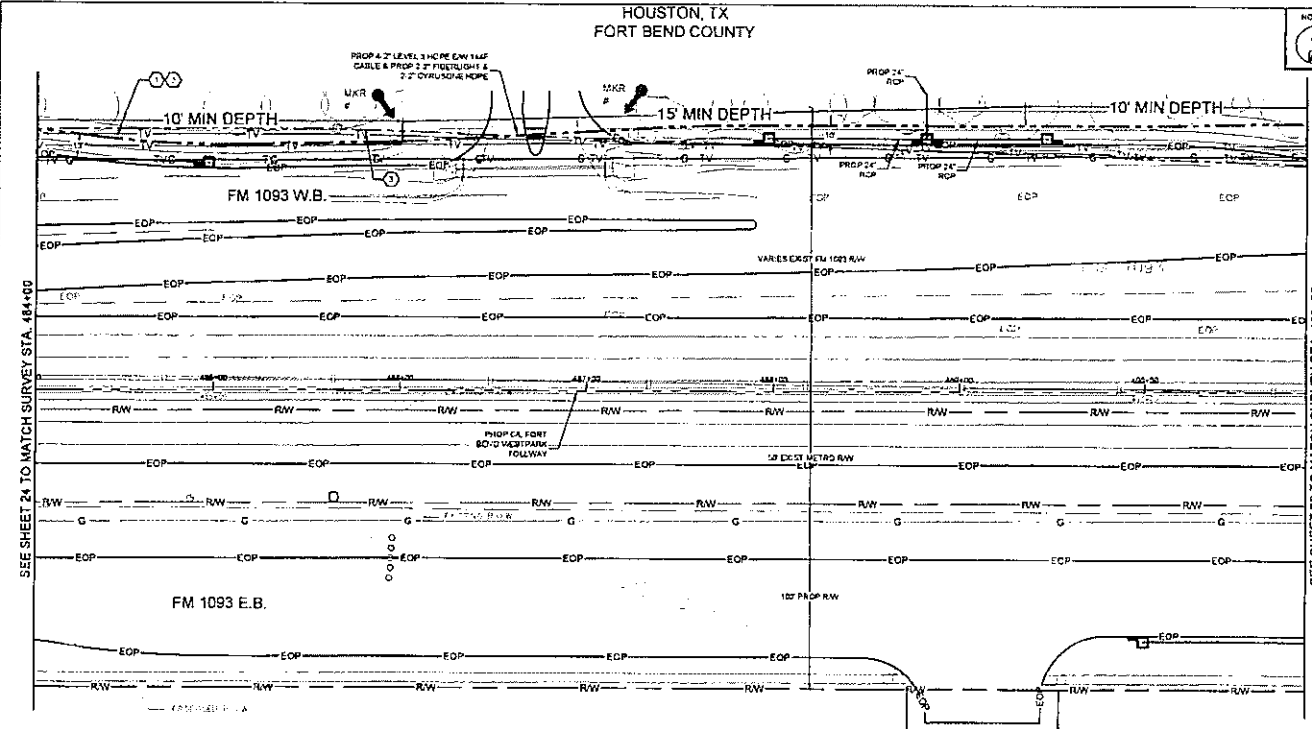

SEE SHEET 24 TO MATCH SURVEY STA. 484+00

SEE SHEET 26 TO MATCH SURVEY STA. 490+00

Page Make Off - Materials

Unit Code & Description	Units	Estimated Quantity	Actual Quantity
MAT 10150 - CONDUIT 8-1/2" HDPE CDR 9	FT	600	
MAT 22070 - WARNING TAGS AND/OR MARKERS	EA	2	

Page Make Off - Work Performed

UM Code & Description	Units	Estimated Quantity	Actual Quantity
UGB-30250-S - DIRECTIONAL BORE GREATER THAN 1500' 1 HDPE CONDUIT UP TO 2"	FT	600	
UGB-30250-S - PLACE UP TO 268 CONDUIT FOC IN CONDUIT. UP TO 1500'	FT	600	
UGB-31020-S - REMOVE AND DISPOSE OF 1-1/4" CABLE	FT	610	
UGB-31020-S - PLACE LOCATE MARKER POST	EA	2	
UGB-30700-S - DR BORE GREATER THAN 1500' ADDITIONAL CONDUIT UP TO 2"	FT	430	

UNDERGROUND UTILITIES HAVE BEEN PLOTTED FROM AVAILABLE RECORDS AND FIELD OBSERVATIONS BUT ARE NOT NECESSARILY EXACT. IT IS THE CONTRACTOR'S RESPONSIBILITY TO FIELD LOCATE ALL UNDERGROUND OBSTRUCTIONS AND UTILITIES PRIOR TO CONSTRUCTION. COMPLETE REPAIR OF ANY AND ALL DAMAGES INCURRED SHALL BE AT THE EXPENSE OF THE CONTRACTOR.



- CONTRACTOR NOTE**
CONTRACTOR MUST SUPPLY ALL HDPE CONDUITS AS NOTED BELOW
- 8-1/2" HDPE CONDUIT
- 4" LEVELS
 - BLACK W/ PURPLE STRIPE
 - BLACK W/ ORANGE STRIPE
 - BLACK W/ GREEN STRIPE
 - BLACK W/ BROWN STRIPE
- 2" FIBERGLASS
- BLACK W/ RED STRIPE
 - BLACK W/ BLUE STRIPE
 - 2" CABLES
 - BLACK W/ WHITE STRIPE
 - BLACK W/ GREY STRIPE

1		
2		
3		
4	DATE	END DESIGN
5	DATE	REVISION # 1
6	DATE	REVISION # 2
7	DATE	REVISION # 3
8	DATE	REVISION # 4
9	DATE	REVISION # 5
10	DATE	REVISION # 6

Level(3)
SURVEYING & ENGINEERING

LEVEL 3 ENGINEER
METHUEN
CONTRACTING FIRM
SOILS/FIELD SERVICES
PROJECT NUMBER
LOCATION: FM 1093 WESTPARK
EXTENSION, HOUSTON, TX
DRAWING NUMBER

SCALE: HORIZ 1"=100'
SHEET 25 OF 31
CONTRACT NUMBER

HOUSTON, TX
FORT BEND COUNTY



CONSTRUCTION NOTES

- 1 CONDUIT OWNER LEVEL 3 CONDUIT LOCATED 200' CONDUIT SIZE 8" CONDUIT TYPE 180P NOTES: REMOVE 8-2" HOPE
- 2 LDD3 HINDOLE CONE 100' 1-144E IN IN
- 3 PROPOSED BOREHOLE
- 4 CONDUIT OWNER LEVEL 3 CONDUIT LOCATED 100' CONDUIT SIZE 8" CONDUIT TYPE 180P NOTES: REMOVE 8-2" HOPE
- 5 CABLE PINS: 144' CABLE OWNER LEVEL 3 CONDUIT LOCATED 100'
- 6 CABLE PINS: 144' CABLE OWNER LEVEL 3 CONDUIT LOCATED 100' NOTES: REMOVE 144' CABLE
- 7 FIBERLINE HINDOLE
- 8 CYLINDRICAL HINDOLE

CONTRACTOR NOTE
CONTRACTOR MUST SUPPLY
ALL HOPE CONDUITS AS
NOTED BELOW

- 8-2 HOPE CONFIGURATION:
- 4-2 LEVEL(1)
 - BLACK W/PURPLE STRIPE
 - BLACK W/ORANGE STRIPE
 - BLACK W/GREEN STRIPE
 - BLACK W/BROWN STRIPE
 - 2-2 FIBERLINE
 - BLACK W/RED STRIPE
 - BLACK W/BLUE STRIPE
 - 2-2 CYLINDRICAL
 - BLACK W/PURPLE STRIPE
 - BLACK W/GREY STRIPE

NO	DATE	REV	REVISION
1			AS-BUILT
2			REVISED # 1
3			ISSUED
4			ISSUED

Level(3)
LEVEL 3 ENGINEER
KATH HILL

ENGINEERING FIRM
5000 WESTPARK DRIVE
HOUSTON, TX 77056
PROJ: 0110001
LOCATION: FM 1093 WESTPARK
EXTENSION HOUSTON, TX
DRAWN BY: JMS

SCALE: HOR: 1"=40'
SHEET: 26 OF 31
CONTRACT: 1440000000

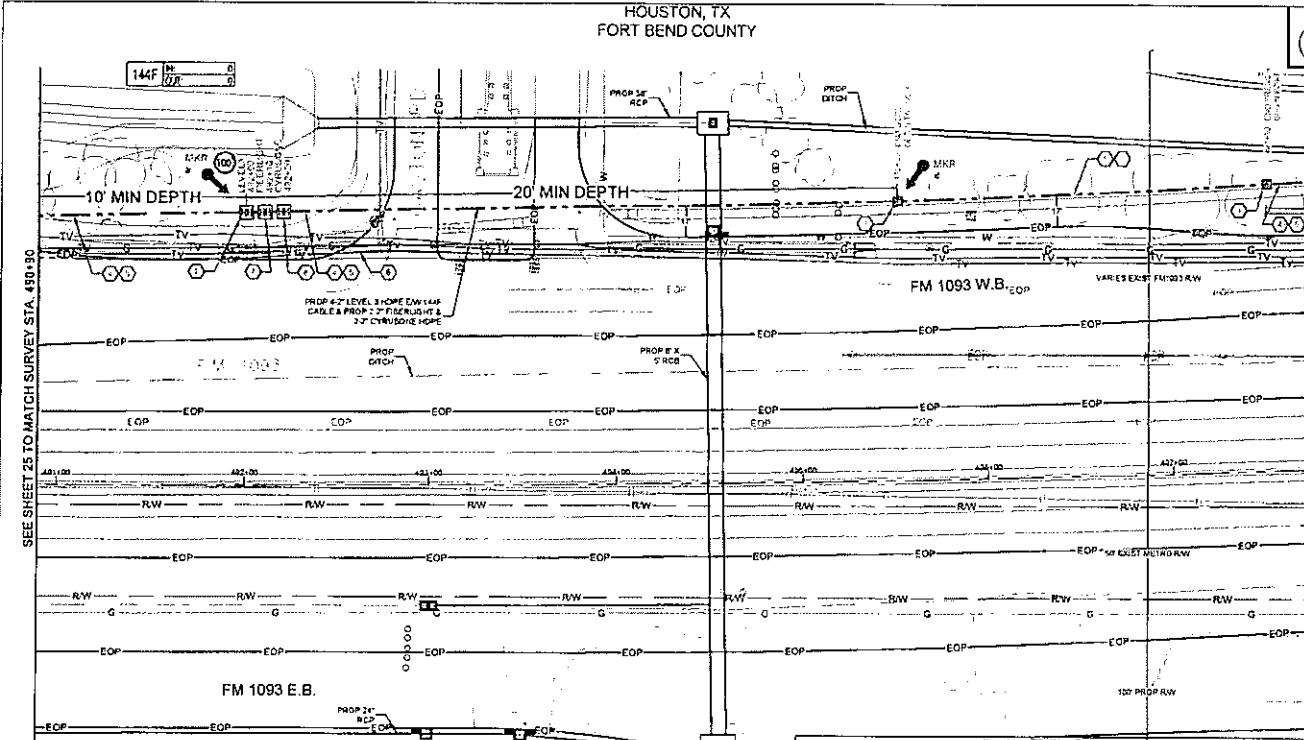

SEE SHEET 25 TO MATCH SURVEY STA. 450+00

SEE SHEET 27 TO MATCH SURVEY STA. 497+78

Page Name: QTY - Materials	Units	Estimated Quantity	Actual Quantity
MAT-00150 - CONDUIT 8" HOPE SDR 9	FT	680	
MAT-00070 - TIE IN 30"x45"x30" WITH KNOCK OUTS AND MARKING - INCLUDING COVER	EA	3	
MAT-00090 - WARNING TAGS AND/OR MARKERS	EA	2	

Page Name: QTY - Work Performed	Units	Estimated Quantity	Actual Quantity
UGB-30002-S - TRENCH GREATER THAN 1500' TRENCH 48" MINIMUM COVER	FT	220	
UGB-30140-S - PLACE 1" HOPE CONDUITS IN OPEN TRENCH UP TO 2'	FT	220	
UGB-30150-S - DIRECTIONAL BORE GREATER THAN 1500' 1 HOPE CONDUIT UP TO 2'	FT	460	
UGB-30160-S - PLACE UP TO 268 COUNT PDC IN CONDUIT UP TO 1500' (100' IN COL)	FT	760	
UGB-31270-S - PLACE NEW .20"x48"x30" - NON-CONCRETE HANDHOLE	EA	3	
UGB-31640-S - EXCAVATE SMALL PIT 6'x4'x3'	EA	2	
UGB-31020-S - REMOVE AND DISPOSE OF 1-144E CABLE	FT	680	
UGB-31290-S - PLACE LOCATE MARKER POST	EA	2	
UGB-32150-S - PLACE ADDITIONAL HOPE IN OPEN TRENCH CONDUIT UP TO 2'	FT	1 540	
UGB-30700-S - DR BORE GREATER THAN 1500' ADDITIONAL CONDUIT UP TO 2'	FT	3 220	



CALL BEFORE YOU DIG
1-800-541-5400
48 HOURS NOTICE REQUIRED

UNDERGROUND UTILITIES HAVE BEEN PLOTTED FROM AVAILABLE RECORDS AND FIELD OBSERVATIONS BUT ARE NOT NECESSARILY EXACT. IT IS THE CONTRACTOR'S RESPONSIBILITY TO FIELD LOCATE ALL UNDERGROUND OBSTRUCTIONS AND UTILITIES PRIOR TO CONSTRUCTION. COMPLETE REPAIR OF ANY AND ALL DAMAGES INCURRED SHALL BE AT THE EXPENSE OF THE CONTRACTOR.

HOUSTON, TX
FORT BEND COUNTY



CONSTRUCTION NOTES

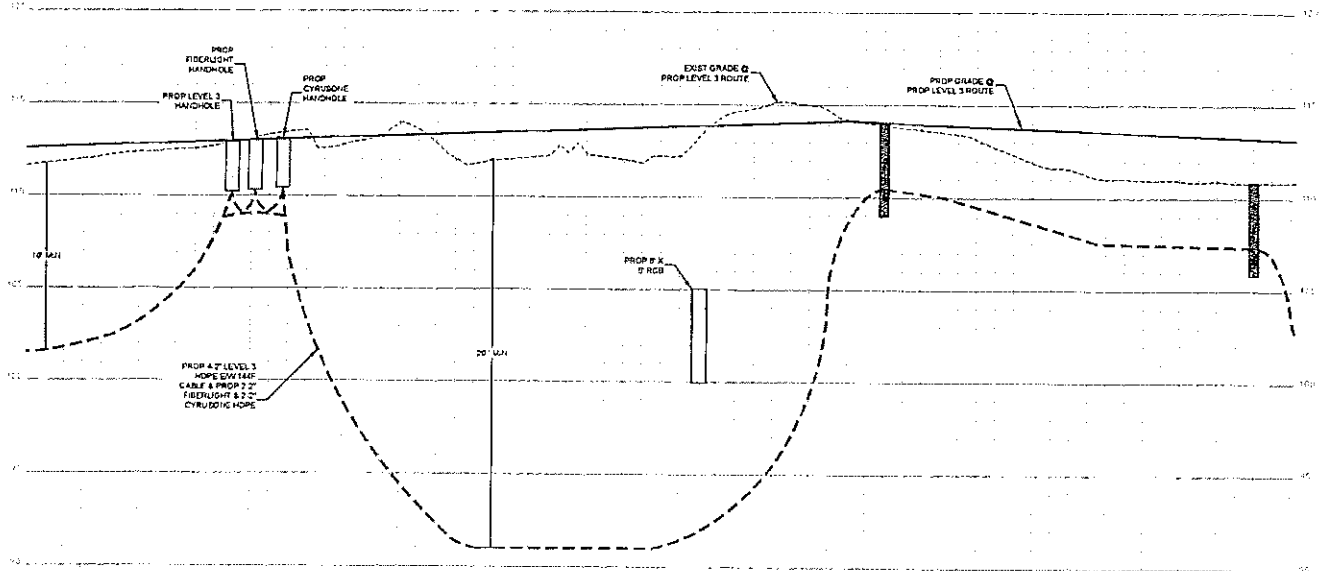

- CONTRACTOR HOPE
CONTRACTOR MUST SUPPLY
ALL HOPE CONDUITS AS
NOTED BELOW
- 8" HOPE CONFIGURATION
- 4" LEVELS)
 - BLACK W/ PURPLE STRIPE
 - BLACK W/ ORANGE STRIPE
 - BLACK W/ GREEN STRIPE
 - BLACK W/ BROWN STRIPE
 - 2" FIBERLIGHT
 - BLACK W/ RED STRIPE
 - BLACK W/ BLUE STRIPE
 - BLACK W/ WHITE STRIPE
 - BLACK W/ GREY STRIPE

NO.	DATE	BY	REVISION
1			
2			
3			

Level(3)
LEVEL 3 ENGINEERING
10000 RICHMOND AVE
HOUSTON, TX 77036
PHONE: 281-291-1111
FAX: 281-291-1112
WWW.LEVEL3ENGINEERING.COM

PROJECT NUMBER: 10000 RICHMOND AVE
LOCATION: 10000 RICHMOND AVE
DATE: 10/15/11

SCALE: VERT 1"=2'
SHEET 28A OF 31
CONTRACT NO. 10000 RICHMOND AVE

UNDERGROUND UTILITIES HAVE BEEN PLOTTED FROM AVAILABLE RECORDS AND FIELD OBSERVATIONS BUT ARE NOT NECESSARILY EXACT. IT IS THE CONTRACTOR'S RESPONSIBILITY TO FIELD LOCATE ALL UNDERGROUND OBSTRUCTIONS AND UTILITIES PRIOR TO CONSTRUCTION. COMPLETE REPAIR OF ANY AND ALL DAMAGES INCURRED SHALL BE AT THE EXPENSE OF THE CONTRACTOR.



CALL BEFORE YOU DIG
1-800-4-A-DIG
48 HOURS NOT TO BE REQUIT

HOUSTON, TX
FORT BEND COUNTY



CONSTRUCTION NOTES

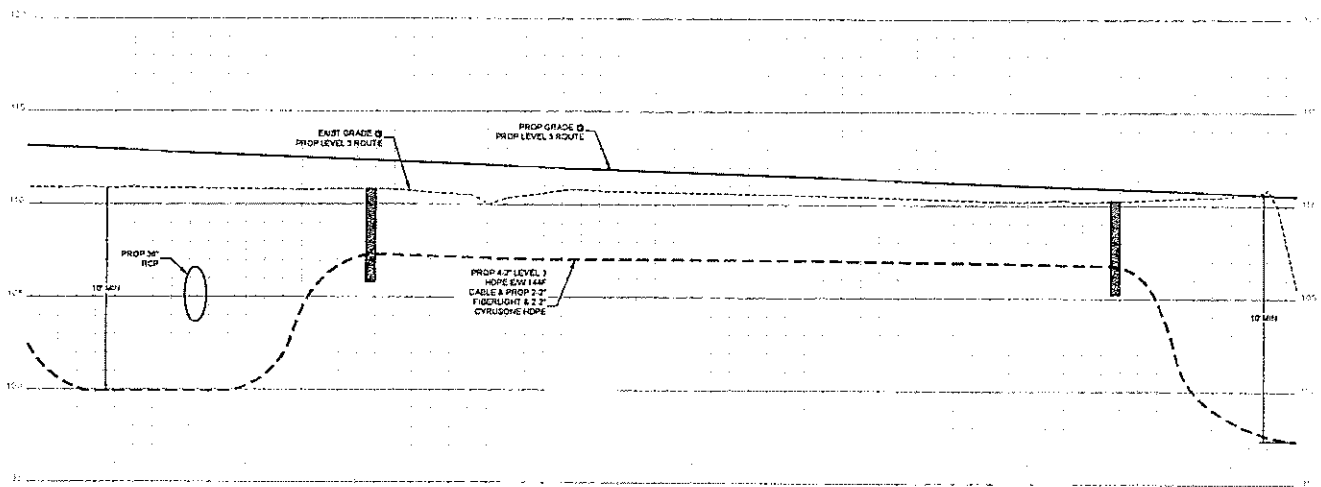

- CONTRACTOR NOTE:
CONTRACTOR MUST SUPPLY
ALL HOPE CONFIGURATIONS AS
NOTED BELOW
- 6\"/>
 - 4\"/>
 - BLACK W/PURPLE STRIPE
 - BLACK W/ORANGE STRIPE
 - BLACK W/GREEN STRIPE
 - BLACK W/BROWN STRIPE
 - 2\"/>
 - BLACK W/RED STRIPE
 - BLACK W/BLUE STRIPE
 - 2\"/>
 - BLACK W/WHITE STRIPE
 - BLACK W/GRAY STRIPE

NO.	DATE	BY	DESCRIPTION
1			
2			

Level(3)
LEVEL ENGINEER

LEVEL ENGINEER
KEITH HALL
ENGINEERING FIRM
CONSULTING SERVICES
PROJECT #A1001A
LOCATION: FM 1053/STRAK
EXTENSION - HOUSTON, TX
DRAWING NO.
SCALE: VERT 1\"/>

UNDERGROUND UTILITIES HAVE BEEN PLOTTED FROM AVAILABLE RECORDS AND FIELD OBSERVATIONS BUT ARE NOT NECESSARILY EXACT. IT IS THE CONTRACTOR'S RESPONSIBILITY TO FIELD LOCATE ALL UNDERGROUND OBSTRUCTIONS AND UTILITIES PRIOR TO CONSTRUCTION. COMPLETE REPAIR OF ANY AND ALL DAMAGES INCURRED SHALL BE AT THE EXPENSE OF THE CONTRACTOR.



HOUSTON, TX
FORT BEND COUNTY



CONSTRUCTION NOTES

1. EXISTING OWNER LEVELS
CONDUIT LOCATED 24" TO 36" DEPTH
CONDUIT SIZE 2"
CONDUIT TYPE: RISE
NOTE: RISE 8-12" DEPTH
2. PROPOSED RISES
3. EXISTING OWNER LEVELS
CONDUIT LOCATED 18" TO 24" DEPTH
CONDUIT SIZE 2"
CONDUIT TYPE: RISE
NOTE: RISE 8-12" DEPTH
4. CABLE MARK: 1-1/4" CABLE OWNER LEVELS
CABLE LOCATED 36"
5. CABLE MARK: 1-1/4" CABLE OWNER LEVELS
CABLE LOCATED 60"
NOTE: MARKER 1-1/4" CABLE

CONTRACTOR NOTE
CONTRACTOR MUST SUPPLY
ALL HOPE CONDUITS AS
NOTED BELOW

- 8-2" HOPE CONFIGURATION
- 4-2" LEVELS
 - BLACK W/ PURPLE STRIPE
 - BLACK W/ ORANGE STRIPE
 - BLACK W/ GREEN STRIPE
 - BLACK W/ BROWN STRIPE
 - 2" FIBER LIGHT
 - BLACK W/ RED STRIPE
 - BLACK W/ BLUE STRIPE
 - 3-2" CIRCULAR
 - BLACK W/ WHITE STRIPE
 - BLACK W/ GREY STRIPE

1	DATE	CHK BY
2		
3		

Page Rate: 0.15 / Work Performed
Units Code & Description

Units Code & Description	Units	Estimated Quantity	Actual Quantity
UGB-30050-S TRENCH GREATER THAN 1500' TRENCH 48" MINIMUM COVER	FT	100	1
UGB-30140-S PLACE 1 HOPE CONDUIT IN OPEN TRENCH UP TO 2"	FT	100	1
UGB-30090-S DIRECTIONAL BORE GREATER THAN 1500' 1 HOPE CONDUIT UP TO 2"	FT	250	1
UGB-30550-S PLACE UP TO 289 COUNT FOC IN CONDUIT UP TO 1500'	FT	650	1
UGB-31640-S EXCAVATE SMALL PIT 6'X6'X5'	EA	2	1
UGB-31000-S REMOVE AND DISPOSL OF 1-1/4" CABLE	FT	220	1
UGB-31950-S PLACE LOCATE MARKER POST	EA	1	1
UGB-30150-S PLACE ADDITIONAL HOPE IN OPEN TRENCH CONDUIT UP TO 2"	FT	700	1
UGB-30100-S DIR BORE GREATER THAN 1500' ADDITIONAL CONDUIT UP TO 2"	FT	4000	1

Unit Code & Description	Units	Estimated Quantity	Actual Quantity
MA1-20120 CONDUIT 8-2" HOPE SDR-B	FT	650	
MA1-20200 WARNING TAGS AND/OR MARKERS	EA	1	



CALL BEFORE YOU DIG
1 800 547-0299
48 HOURS NOTICE REQUIRED

UNDERGROUND UTILITIES HAVE BEEN PLOTTED FROM AVAILABLE RECORDS AND FIELD OBSERVATIONS BUT ARE NOT NECESSARILY EXACT. IT IS THE CONTRACTOR'S RESPONSIBILITY TO FIELD LOCATE ALL UNDERGROUND OBSTRUCTIONS AND UTILITIES PRIOR TO CONSTRUCTION. COMPLETE REPAIR OF ANY AND ALL DAMAGES INCURRED SHALL BE AT THE EXPENSE OF THE CONTRACTOR.

SEE SHEET 27 TO MATCH SURVEY STA. 504+50

SEE SHEET 28 TO MATCH SURVEY STA. 511+30

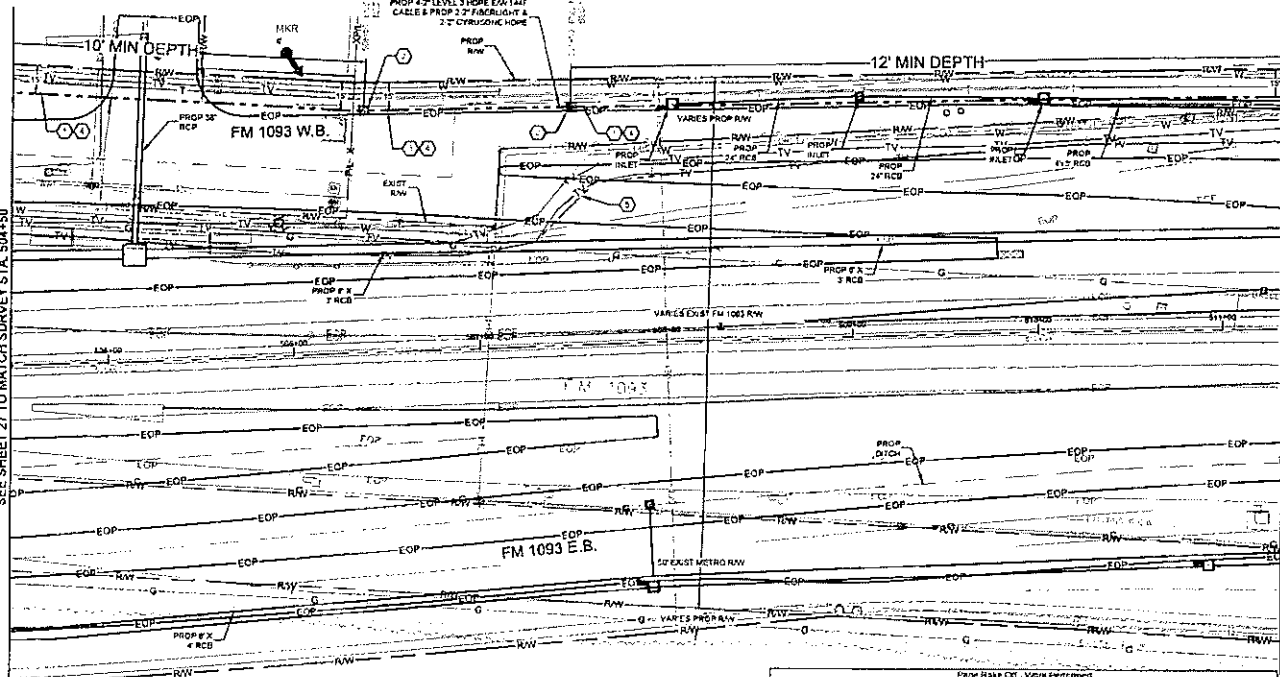

HOUSTON, TX
FORT BEND COUNTY



CONSTRUCTION NOTES

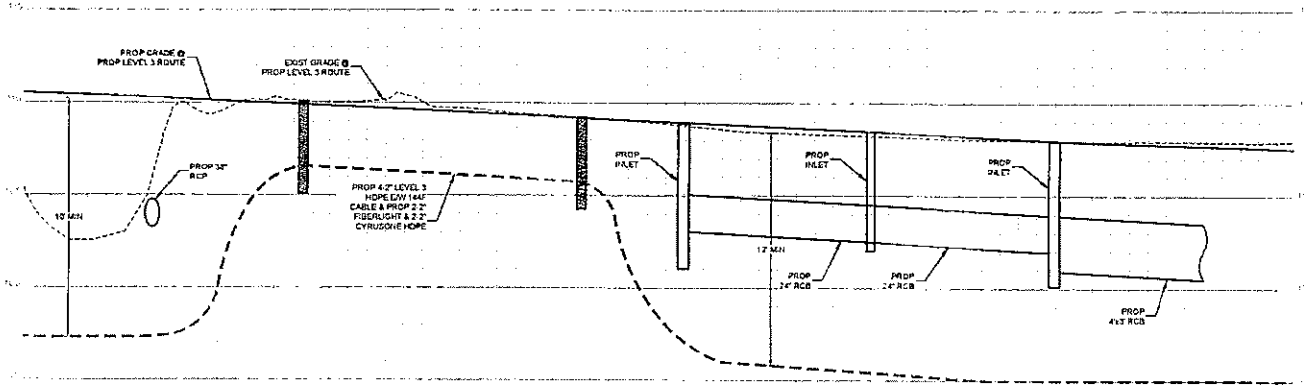

- CONTRACTOR NOTE:
CONTRACTOR MUST SUPPLY ALL HOPE CONDUITS AS NOTED BELOW
- 8\"/>
 - 4\"/>
 - BLACK W/ PURPLE STRIPE
 - BLACK W/ ORANGE STRIPE
 - BLACK W/ GREEN STRIPE
 - BLACK W/ BROWN STRIPE
 - 12\"/>
 - BLACK W/ RED STRIPE
 - BLACK W/ BLUE STRIPE
 - 12\"/>
 - BLACK W/ WHITE STRIPE
 - BLACK W/ GREY STRIPE

NO.	DATE	BY	CHK. DESIGN
1			
2			
3			
4			
5			
6			
7			
8			
9			
10			
11			
12			
13			
14			
15			
16			
17			
18			
19			
20			
21			
22			
23			
24			
25			
26			
27			
28			
29			
30			
31			
32			
33			
34			
35			
36			
37			
38			
39			
40			
41			
42			
43			
44			
45			
46			
47			
48			
49			
50			
51			
52			
53			
54			
55			
56			
57			
58			
59			
60			
61			
62			
63			
64			
65			
66			
67			
68			
69			
70			
71			
72			
73			
74			
75			
76			
77			
78			
79			
80			
81			
82			
83			
84			
85			
86			
87			
88			
89			
90			
91			
92			
93			
94			
95			
96			
97			
98			
99			
100			

Level(3)
LEVEL 3 ENGINEER
REGISTERED
ENGINEERING FIRM
GOLDEN FELD SERVICES
PROJECT NUMBER
LOCATION: 4840 WYVICK PARK
EXTENSION, HOUSTON, TX
DRAWING NAME

SCALE: 1/4" = 1'-0"
SHEET 08A OF 31
COPYRIGHT PROPRIETARY



CALL BEFORE YOU DIG
1-800-4-A-DIG
41 HOUR NOTICE REQUIRED

UNDERGROUND UTILITIES HAVE BEEN PLOTTED FROM AVAILABLE RECORDS AND FIELD OBSERVATIONS BUT ARE NOT NECESSARILY EXACT. IT IS THE CONTRACTOR'S RESPONSIBILITY TO FIELD LOCATE ALL UNDERGROUND OBSTRUCTIONS AND UTILITIES PRIOR TO CONSTRUCTION. COMPLETE REPAIR OF ANY AND ALL DAMAGES INCURRED SHALL BE AT THE EXPENSE OF THE CONTRACTOR.

HOUSTON, TX
FORT BEND COUNTY

144F
1/8" = 100'



CONSTRUCTION NOTES

1. REMOVE OVER LEVELS
CONDUIT LENGTH 200'
CONDUIT SIZE 2"
CONDUIT TYPE: HDPE
NOTE: REMOVE 8'-2" HDPE
2. REMOVE OVER LEVELS
CONDUIT LENGTH 140'
CONDUIT SIZE 2"
CONDUIT TYPE: HDPE
NOTE: REMOVE 8'-2" HDPE
3. REMOVE OVER LEVELS
CONDUIT LENGTH 100'
CONDUIT SIZE 2"
CONDUIT TYPE: HDPE
NOTE: REMOVE 8'-2" HDPE
4. REMOVE OVER LEVELS
CONDUIT LENGTH 100'
CONDUIT SIZE 2"
CONDUIT TYPE: HDPE
NOTE: REMOVE 8'-2" HDPE
5. REMOVE OVER LEVELS
CONDUIT LENGTH 100'
CONDUIT SIZE 2"
CONDUIT TYPE: HDPE
NOTE: REMOVE 8'-2" HDPE
6. REMOVE OVER LEVELS
CONDUIT LENGTH 100'
CONDUIT SIZE 2"
CONDUIT TYPE: HDPE
NOTE: REMOVE 8'-2" HDPE
7. REMOVE OVER LEVELS
CONDUIT LENGTH 100'
CONDUIT SIZE 2"
CONDUIT TYPE: HDPE
NOTE: REMOVE 8'-2" HDPE
8. REMOVE OVER LEVELS
CONDUIT LENGTH 100'
CONDUIT SIZE 2"
CONDUIT TYPE: HDPE
NOTE: REMOVE 8'-2" HDPE
9. REMOVE OVER LEVELS
CONDUIT LENGTH 100'
CONDUIT SIZE 2"
CONDUIT TYPE: HDPE
NOTE: REMOVE 8'-2" HDPE

CONTRACTOR NOTE:
CONTRACTOR MUST SUPPLY
ALL HDPE CONDUITS AS
NOTED BELOW

- 6" HDPE CONFIGURATION
- 4-2 LEVELS
 - BLACK W/ PURPLE STRIPE
 - BLACK W/ GREEN STRIPE
 - BLACK W/ BROWN STRIPE
 - 2" FIBERGLITE
 - BLACK W/ RED STRIPE
 - BLACK W/ BLUE STRIPE
 - 2" EXHUSION
 - BLACK W/ WHITE STRIPE
 - BLACK W/ GREY STRIPE

REV	DATE	ENG DETAIL
1		
2		

REV	DATE	ENG DETAIL
1		
2		

Level (3)
EARTH SYSTEMS

LEVEL ENGINEER
METH HALL
ENGINEERING FIRM
GOLDENFIELD EXP/CLS
PROJECT NUMBER
LOCATION: FORT BEND COUNTY
EXTENSION: HOUSTON TX
DRAWING NUMBER

SCALE: HOR 1"=50'
SHEET 28 OF 31
COPYRIGHT 2014 BY LEVEL (3) EARTH SYSTEMS

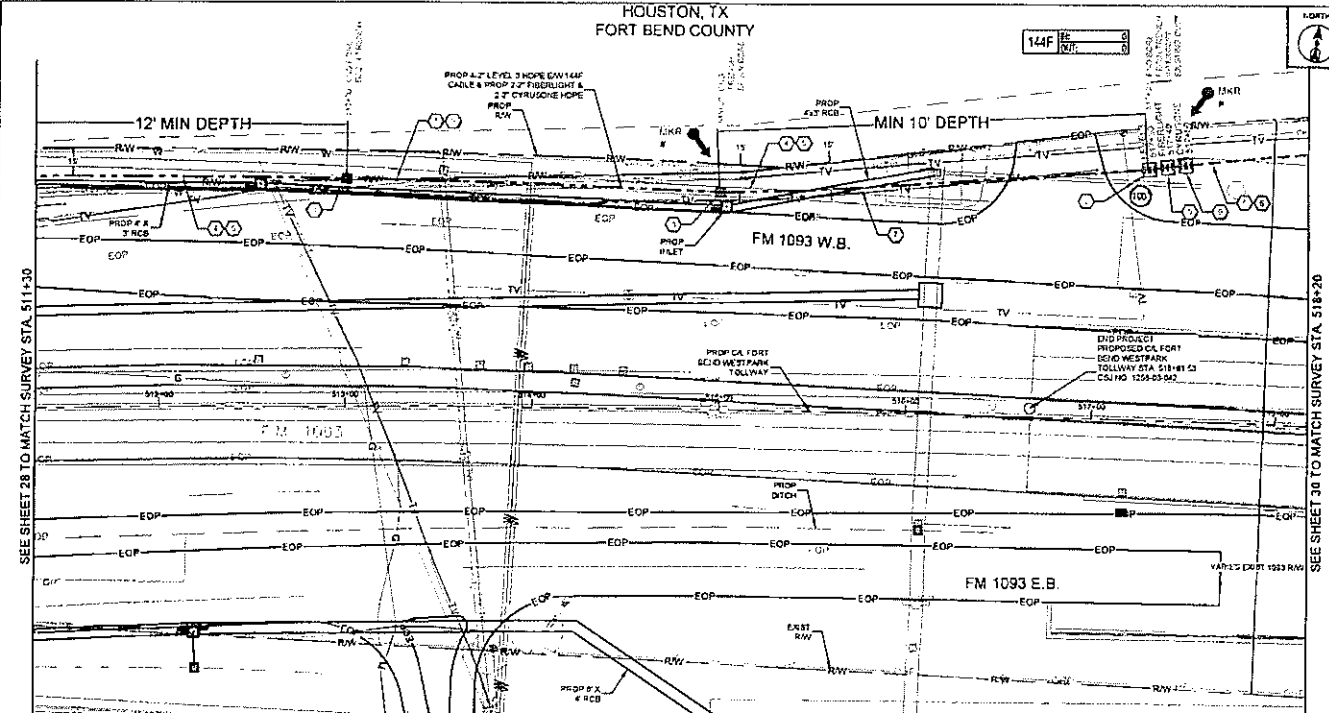

SEE SHEET 28 TO MATCH SURVEY STA. 511+30

SEE SHEET 30 TO MATCH SURVEY STA. 518+20

Unit Code & Description	Units	Estimated Quantity	Actual Quantity
MAT-20155 - CONDUIT 8-2" HDPE GOR 0	FT	600	
MAT-20270 - TIER 15 337648735" WITH KNOCK-OUTS AND RACKING - INCLUDING COVER	EA	3	
MAT-20320 - CONDUIT WYE CAST 2"	EA	1	
MAT-20200 - WARNING TAGS AND/OR MARKERS	EA	2	

Unit Code & Description	Units	Estimated Quantity	Actual Quantity
UGB-30053-S - TRENCH GREATER THAN 1500' TRENCH 48" MINIMUM COVER	FT	200	
UGB-30140-S - PLACE 1" HDPE CONDUITS IN OPEN TRENCH UP TO 2"	FT	200	
UGB-30050-S - DIRECTIONAL BORE GREATER THAN 1500' 1 HDPE CONDUIT UP TO 2"	FT	400	
UGB-30050-S - PLACE UP TO 218 COUNT FOC IN CONDUIT UP TO 1500' (100 IN COLL)	FT	780	
UGB-31270-S - PLACE NEW 337648735" HDPE CONCRETE HANDHOLE	EA	3	
UGB-31640-S - EXCAVATE ON ALL PITS EXIST	EA	2	
UGB-31002-S - REMOVE AND DISPOSE OF 1-1/4" CABLE	EY	600	
UGB-30220-S - INTERCEPT CONDUIT WYE CAST 2"	EA	1	
UGB-31270-S - PLACE LOCATE MARKER POST	EA	2	
UGB-30150-S - PLACE ADDITIONAL HDPE IN OPEN TRENCH CONDUIT UP TO 2"	FT	1400	
UGB-30700-S - DR. BORE GREATER THAN 1500' ADDITIONAL CONDUIT UP TO 2"	FT	2800	

UNDERGROUND UTILITIES HAVE BEEN PLOTTED FROM AVAILABLE RECORDS AND FIELD OBSERVATIONS BUT ARE NOT NECESSARILY EXACT. IT IS THE CONTRACTOR'S RESPONSIBILITY TO FIELD LOCATE ALL UNDERGROUND OBSTRUCTIONS AND UTILITIES PRIOR TO CONSTRUCTION. COMPLETE REPAIR OF ANY AND ALL DAMAGES INCURRED SHALL BE AT THE EXPENSE OF THE CONTRACTOR.



CALL BEFORE YOU DIG
1-800-4-A-SHARES
48 HOURS NOTICE REQUIRED

HOUSTON, TX
FORT BEND COUNTY



CONSTRUCTION NOTES

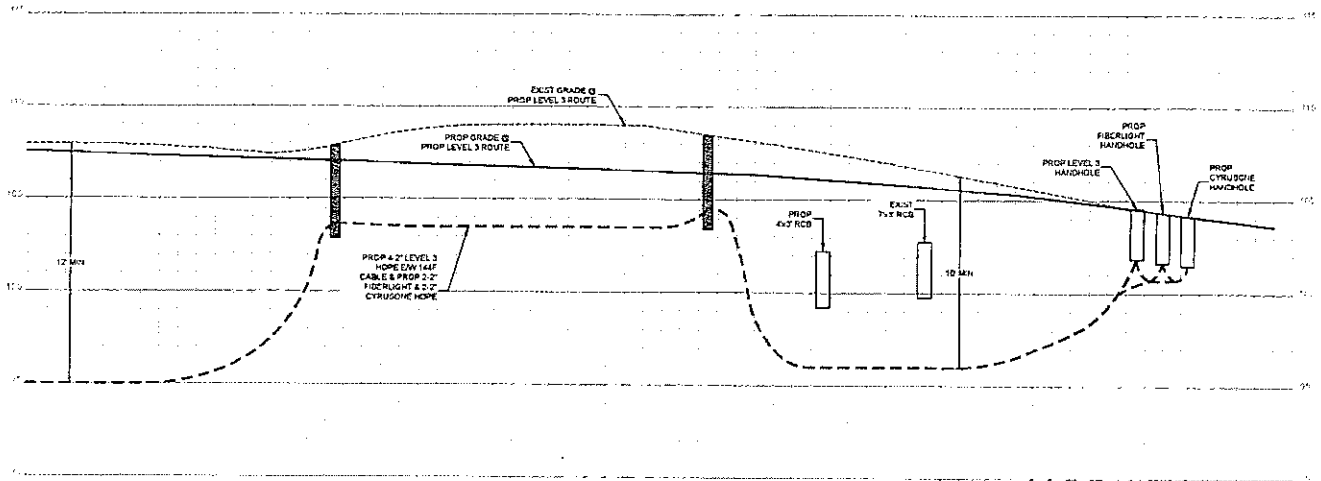

- CONTRACTOR NOTE
CONTRACTOR MUST SUPPLY
ALL HOPE COORDINATE AS
NOTED BELOW
- 52" HOPE CONFIGURATION
4" LEVEL 0/1
 BLACK W/ PURPLE STRIPE
 BLACK W/ ORANGE STRIPE
 BLACK W/ GREEN STRIPE
 BLACK W/ BROWN STRIPE
- 5" FIBER OPTIC
 BLACK W/ RED STRIPE
 BLACK W/ BLUE STRIPE
- 2" CYRUSOIE
 BLACK W/ WHITE STRIPE
 BLACK W/ GREY STRIPE

1	
1	
1	
1	ONE DESIGN
3-3-18	AS-BUILT
11-15-15	REVISION 2
	ORIGINAL
	CONTRACT

Level(3)
CONSTRUCTION SERVICES

LEVEL ENGINEER
KEITH HILL

ENGINEER REG. NO. 10000
100000 FIELD SERVICES

PROJECT MANAGER

LOCATION: FM 1031 HASLIP PARK
EASTHOUS, HOUSTON, TX

DRAWING NAME

SCALE: VERT 1"=5'

SHEET 29A OF 31

DATE OF PLOT: 11/15/15



UNDERGROUND UTILITIES HAVE BEEN PLOTTED FROM AVAILABLE RECORDS AND FIELD OBSERVATIONS BUT ARE NOT NECESSARILY EXACT. IT IS THE CONTRACTOR'S RESPONSIBILITY TO FIELD LOCATE ALL UNDERGROUND OBSTRUCTIONS AND UTILITIES PRIOR TO CONSTRUCTION. COMPLETE REPAIR OF ANY AND ALL DAMAGES INCURRED SHALL BE AT THE EXPENSE OF THE CONTRACTOR.

CALL BEFORE YOU DIG
1-800-545-6225
48 HOURS NOTICE REQUIRED

HOUSTON, TX
FORT BEND COUNTY

SEE SHEET 29 TO MATCH SURVEY STA. 517+90

FM 1093 V.B.

Page Take Off - Work Performed			
Unit Code & Description	Units	Estimated Quantity	Actual Quantity
UGB-3052D-S - PLACE UP TO 218 COUNT FCC IN CONDUIT. UP TO 1500' (100' IN COIL)	FT	737	
UGB-3162D-S - CORE BORE 1/4" 2" OUTSIDE DIAMETER	EA	1	
UGB-3182D-S - REMOVE AND DISPOSE OF 1-1/4" CABLE	EA	632	



CONSTRUCTION NOTES

- ① CONDUIT OWNER LEVELS
CONDUIT LENGTH: 632'
CONDUIT SIZE: 8"
CONDUIT TYPE: HDPE
- ② CABLE FEEDS: 144F
CABLE OWNER LEVELS
CABLE LENGTH: 737'
NOTE: INCLUDE CREEPING CONDUIT
- ③ CABLE FEEDS: 144F
CABLE OWNER LEVELS
CABLE LENGTH: 632'
NOTE: REMOVE 1/4" CABLE

- CONTRACTOR NOTE:
ELECTRICAL CONDUIT SUPPLY
ALL HDPE CONDUITS AS
NOTED BELOW.
- 8" HDPE CONFIGURATION:
4" LEVEL(1)
○ BLACK W/ PURPLE STRIPE
○ BLACK W/ ORANGE STRIPE
○ BLACK W/ GREEN STRIPE
○ BLACK W/ BROWN STRIPE
- 2" FIBER OPTIC
○ BLACK W/ RED STRIPE
○ BLACK W/ BLUE STRIPE
- 2" CRYSTAL
○ BLACK W/ WHITE STRIPE
○ BLACK W/ GREY STRIPE

NO.	DATE	BY	REVISION
1			REVISED
2			REVISED

Level(3)
REGISTERED PROFESSIONAL ENGINEER
NO. 12345
STATE OF TEXAS

ENGINEERING FIRM
OKOCH FIELD SERVICES
PROJECT NUMBER:
LOCATION: FM 1023 WESTPARK
EXTENSION - HOUSTON, TX
DATE: 10/20/2023

SCALE: HORIZ. 1"=20'
SHEET: 30 OF 31
CONFIDENTIAL PROJECT (ART)

UNDERGROUND UTILITIES HAVE BEEN PLOTTED FROM AVAILABLE RECORDS AND FIELD OBSERVATIONS BUT ARE NOT NECESSARILY EXACT. IT IS THE CONTRACTOR'S RESPONSIBILITY TO FIELD LOCATE ALL UNDERGROUND CONSTRUCTIONS AND UTILITIES PRIOR TO CONSTRUCTION. COMPLETE REPAIR OF ANY AND ALL DAMAGES INCURRED SHALL BE AT THE EXPENSE OF THE CONTRACTOR.



CALL BEFORE YOU DIG
1-800-545-6055
48 HOURS NOTICE REQUIRED

TRAFFIC PATTERN

144F

EXIST. SPACE POINT

LEVELS

HANDHOLE DETAIL

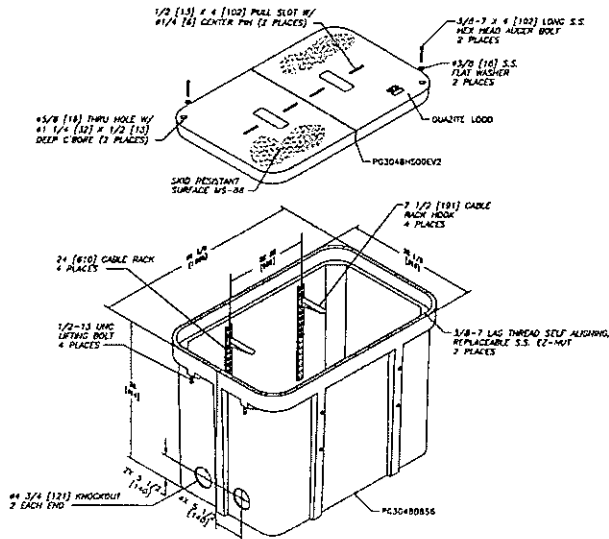

TYPICAL DETAIL -- A

30X48X36 ASSEMBLY
 W/ (4) 24" CABLE RACKS
 & (4) 7 1/2" HOOKS
 PG304B2987EV2
 QUARTZ -- 25479885

CONTRACTOR NOTE
 CONTRACTOR MUST SUPPLY
 ALL HOME COORDINATED AS
 NOTED BELOW

- 1.7" HOPE CONFIGURATION
 4" LEVELS
- BLACK W/ PINK STRIPE
 - BLACK W/ ORANGE STRIPE
 - BLACK W/ GREEN STRIPE
 - BLACK W/ BROWN STRIPE
- 2.7" BRESLIGHT
- BLACK W/ RED STRIPE
 - BLACK W/ BLUE STRIPE
- 2.7" STRUSONE
- BLACK W/ WHITE STRIPE
 - BLACK W/ GRAY STRIPE

1	
2	
3	
4	
5	
6	
7	
8	
9	
10	
11	
12	
13	
14	
15	
16	
17	
18	
19	
20	
21	
22	
23	
24	
25	
26	
27	
28	
29	
30	
31	
32	
33	
34	
35	
36	
37	
38	
39	
40	
41	
42	
43	
44	
45	
46	
47	
48	
49	
50	
51	
52	
53	
54	
55	
56	
57	
58	
59	
60	
61	
62	
63	
64	
65	
66	
67	
68	
69	
70	
71	
72	
73	
74	
75	
76	
77	
78	
79	
80	
81	
82	
83	
84	
85	
86	
87	
88	
89	
90	
91	
92	
93	
94	
95	
96	
97	
98	
99	
100	

Level(3)
 LEVEL 3 ENGINEER
 4000 W. 10TH AVENUE
 DENVER, CO 80202
 PHONE: 303.733.1111
 FAX: 303.733.1112
 WWW.LEVEL3.COM

PROJECT NUMBER
 LOCATION: 4th 125th ST PARK
 EXTENSION - HOUSE 18
 DRAWING NUMBER

SHEET 30A OF 31
 1/20/2012 10:40 AM

CONSTRUCTION DETAIL

TYPICAL DETAIL "A"
TRENCH & PLACE CONDUIT

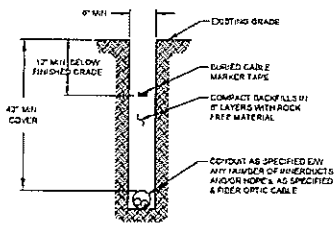

TYPICAL DETAIL "B"
CROSS SECTION OF PROPOSED HDPE

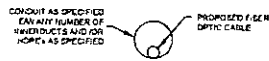

TYPICAL DETAIL "C"
DIRECTIONAL BORE CROSS SECTION FOR CONDUIT

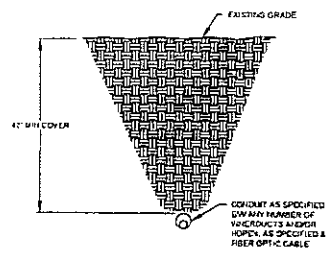

TYPICAL DETAIL "D"
HDPE CONFIGURATION

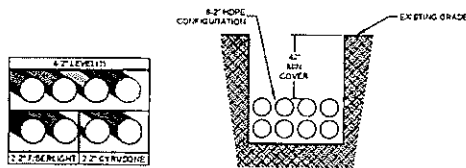

4" LEVELS BLACK W/ PURPLE STRIPE BLACK W/ ORANGE STRIPE BLACK W/ GREEN STRIPE BLACK W/ BROWN STRIPE	2" FIBER/LIGHT BLACK W/ RED STRIPE BLACK W/ BLUE STRIPE	1" CYRUSONE BLACK W/ WHITE STRIPE BLACK W/ GREY STRIPE
8-2" HDPE CONFIGURATION		

- CONCRETE NOTE**
CONTRACTOR MUST SUPPLY ALL HDPE CONDUITS AS NOTED EIT/DW
- 4" LEVELS**
- BLACK W/ PURPLE STRIPE
 - BLACK W/ ORANGE STRIPE
 - BLACK W/ GREEN STRIPE
 - BLACK W/ BROWN STRIPE
- 2" FIBER/LIGHT**
- BLACK W/ RED STRIPE
 - BLACK W/ BLUE STRIPE
- 1" CYRUSONE**
- BLACK W/ WHITE STRIPE
 - BLACK W/ GREY STRIPE

3		
2		
1		
NO.	DATE	THIS DESIGN
1	10/1/18	AS SHOWN
2	3/3/18	REVISION #1
3	11/15/18	ORIGINAL
DATE/TIME	COMMENTS	
Level(3)		
LEVEL 3 ENGINEER		
REGISTERED PROFESSIONAL ENGINEER		
EXPIRES 12/31/2024		
PROJECT NUMBER		
LOCATION: FM 1875V E STP44		
EXTENSION: HOUSTON TX		
DRAWING SCALE		
SHEET 308 OF 31		
CONFIDENTIAL/PROPRIETARY		

LEVEL 3 CABLE PULLING SCHEMATIC
NOT TO SCALE

LEVEL 3 CABLE TABULATION
 TOTAL FIBER PLACED IN PROP DUCT: 17,455'
 TOTAL FIBER PLACED IN EXIST DUCT: 722'
 TOTAL PROP FIBER FOOTAGE: 18,177'
 (TOTAL FOOTAGE DOES NOT INCLUDE 1,000' IN COILS)

CONSTRUCTION NOTE:
 FIBERLIGHT & CYRUSONE HANDHOLES
 NOT SHOWN FOR CLARITY

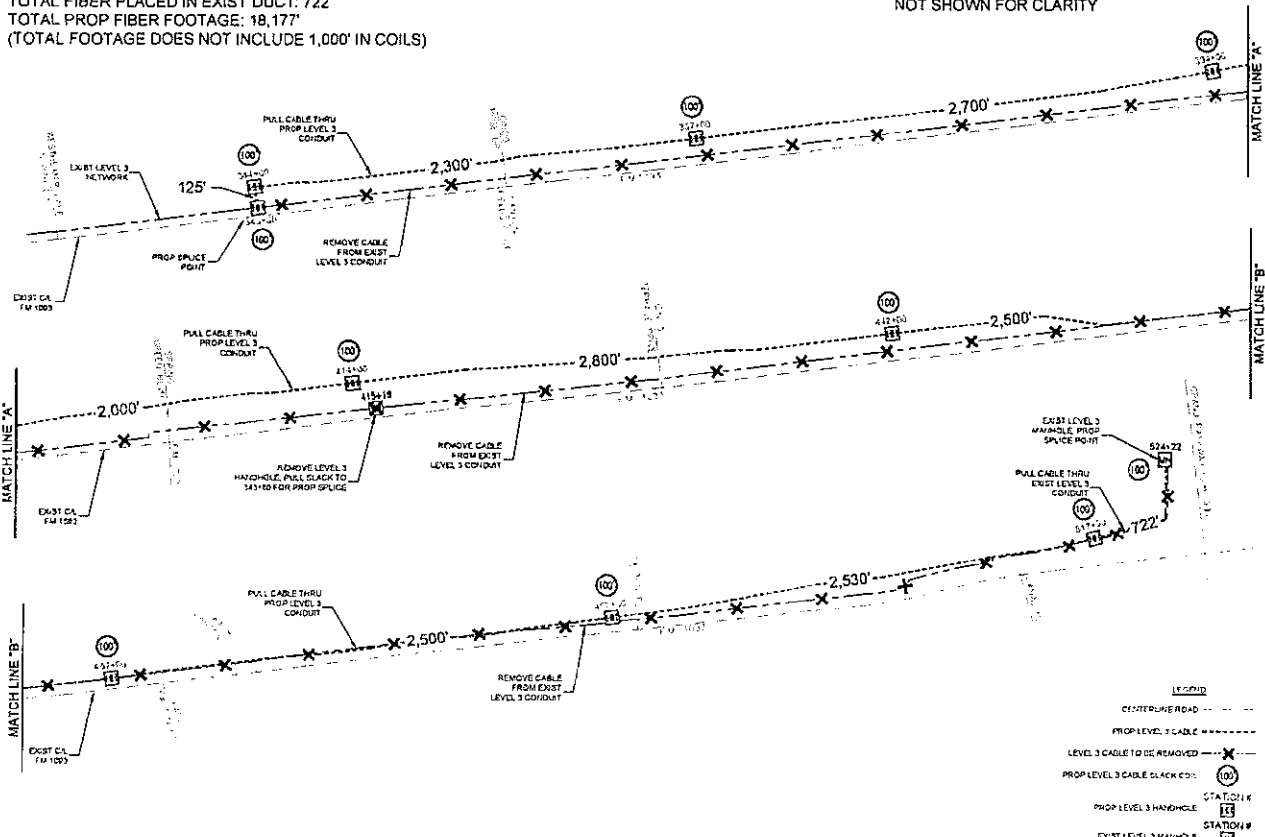

CONTRACTOR NOTE:
 CONTRACTOR MUST SUPPLY
 ALL HOPE CONDUITS AS
 NOTED BELOW

3" HOPE CONFIGURATION

- 4" 2" LEVELS
- BLACK W/ PURPLE STRIPE
- BLACK W/ ORANGE STRIPE
- BLACK W/ RED STRIPE
- BLACK W/ BROWN STRIPE

3" FIBERLIGHT

- BLACK W/ RED STRIPE
- BLACK W/ BLUE STRIPE
- 3" CONDUIT
- BLACK W/ WHITE STRIPE
- BLACK W/ GREY STRIPE

1		
2		
3		
4		
5		
6		
7		
8		
9		
10		
11		
12		
13		
14		
15		
16		
17		
18		
19		
20		
21		
22		
23		
24		
25		
26		
27		
28		
29		
30		
31		
32		
33		
34		
35		
36		
37		
38		
39		
40		
41		
42		
43		
44		
45		
46		
47		
48		
49		
50		
51		
52		
53		
54		
55		
56		
57		
58		
59		
60		
61		
62		
63		
64		
65		
66		
67		
68		
69		
70		
71		
72		
73		
74		
75		
76		
77		
78		
79		
80		
81		
82		
83		
84		
85		
86		
87		
88		
89		
90		
91		
92		
93		
94		
95		
96		
97		
98		
99		
100		

Legend

- CENTERLINE/DAD
- PROP LEVEL 3 CABLE
- LEVEL 3 CABLE TO BE REMOVED
- PROP LEVEL 3 CABLE SLACK COIL
- PROP LEVEL 3 HANDHOLE
- EXIST LEVEL 3 MANHOLE

Level(3)

LEVEL 3 ENGINEER
 HEALTH HALL
 ENGINEER-IN-CHARGE
 QUALITY FIELD SERVICES
 PROJECT NUMBER
 LOCATION: FM 1003 H&E ST PARK
 EXTENSION, HOUSTON, TX
 DRAWING NUMBER

SHEET 30C OF 31
 DATE: 02/14/2014

RAKE OFF - WORK PERFORMED			
Unit Code & Description	Units	Estimated Quantity	Actual Quantity
UGB-30050-S - TRENCH GREATER THAN 1500' TRENCH 48" MINIMUM COVER	FT	9,105	
UGB-30140-S - PLACE 1 - HDPE CONDUITS IN OPEN TRENCH UP TO 2"	FT	9,105	
UGB-30150-S - PLACE ADDITIONAL HDPE IN OPEN TRENCH CONDUIT UP TO 2"	FT	83,735	
UGB-30690-S - DIRECTIONAL BORE GREATER THAN 1500' 1 HDPE CONDUIT UP TO 2"	FT	8,350	
UGB-30700-S - DIR. BORE GREATER THAN 1500' ADDITIONAL CONDUIT UP TO 2"	FT	58,450	
UGB-30860-S - PLACE UP TO 288 COUNT FGC IN CONDUIT, UP TO 1500' (1,000' IN COIL)	FT	19,177	
UGB-31270-S - PLACE NEW - 30"x48"x36" - NON-CONCRETE HANDHOLE	EA	27	
UGB-31640-S - EXCAVATE SMALL PIT 6'X4'X5'	EA	34	
UGB-31600-S - CORE BORE MH 2" OUTSIDE DIAMETER	EA	1	
UGB-30930-S - INTERCEPT CONDUIT WYE CAST 2"	EA	2	
UGB-31060-S - REMOVE AND DISPOSE OF 1-144F CABLE	FT	18,052	
UGB-31380-S - REMOVE EXISTING - 30"x48"x36" - NON-CONCRETE HANDHOLE	EA	1	
UGB-31990-S - PLACE LOCATE MARKER POST	EA	39	

RAKE OFF - MATERIALS LIST			
Unit Code & Description	Units	Estimated Quantity	Actual Quantity
MAT-90150 - CONDUIT 8-2" HDPE SDR-9	FT	17,435	
MAT-90970 - TIER 15 30"x48"x36" - W/ KNOCK-OUTS AND RACKING - INCLUDING COVER	EA	27	
MAT-90380 - CONDUIT WYE CAST 2"	EA	1	
MAT-92090 - WARNING TAGS AND/OR MARKERS	EA	39	

CONTRACTOR TO BE
 RESPONSIBLE FOR SUPPLY
 ALL HDPE CONDUITS AS
 NOTED BELOW

- 3" HDPE CONFIGURATION
 4" (LEVEL)
 BLACK W/ PURPLE STRIPE
 BLACK W/ ORANGE STRIPE
 BLACK W/ GREEN STRIPE
 BLACK W/ BRN/CH STRIPE
 2" HDPE
 BLACK W/ RED STRIPE
 BLACK W/ BLUE STRIPE
 2" CYRUS
 BLACK W/ WHITE STRIPE
 BLACK W/ GREY STRIPE

1			
1			
NO.	DATE	ENG. REVISION	
2-3-14		AS-BUILT	
11-12-15		REVISED	
DRAWING		CONTRACT	

Level(3)
 CONSULTANTS

LEVEL 3 ENGINEER
 REGISTERED
 ENGINEERING FIRM
 GOLDEN FIELD SERVICES
 PROJECT NUMBER
 LOCATION: FM 1574 WESTPARK
 EXTENSION - HOUSTON, TX
 DRAWING TITLE

SHEET 31 OF 31
 CONFIDENTIAL/PROPRIETARY

Exhibit B

**CyrusOne
Construction Cost Estimate**

WST 3/30/16
Date
Fort Bend County

GA 3/29/16
Initial Date
CyrusOne

Utility Relocation Cost Estimate

Sow	FM 1093 and Westpark Relo		
Description	Relocation Construction		
Market	TX, Houston		
PA	98059	4 conduits	
	Original Directional Boring Contractor	Original Contractor	Original Cost Breakdown
UGB-30050:UGB:Trench Greater Than 1500':Trench greater than 1500': Trench 48" minimum cover	\$ 150,232.50	\$ 75,116.25	Cost divided via pro-rata
UGB-30140:UGB:Conduit / Casing - Place in Trench:Place 1 - HDPE conduit in open trench up to 2"	\$ 15,933.75	\$ 7,966.88	Cost divided via pro-rata
UGB-30150:UGB:Conduit / Casing - Place in Trench:Place additional HDPE in open trench conduit up to 2"	\$ 66,921.75	\$ 33,460.88	Cost divided via pro-rata
UGB-30690:UGB:Directional Bore Greater Than 1500':Directional Bore greater than 1500': 1 HDPE conduit up to 2"	\$ 154,475.00	\$ 77,237.50	Cost divided via pro-rata
UGB-30700:UGB:Directional Bore Greater Than 1500':Directional Bore greater than 1500': Additional HDPE conduit up to 2"	\$ 175,350.00	\$ 87,675.00	Cost divided via pro-rata
UGB-31270:UGB:Handhole / Manhole Excavation & Placement:Place New - 30"x48"x36" - Non-concrete Manhole / Handhole	\$ 21,735.00	\$ 5,433.75	Costs divided 4 ways.
UGB-31640:UGB:Pits:Excavate Small Pit: 6'x4'x5'	\$ 31,620.00	\$ 15,810.00	Cost divided via pro-rata
MAT-90970:MAT:Handhole / Manhole:Tier 15 30"x48"x36" - With knock-outs and racking - Including Cover	\$ 17,550.00	\$ 4,387.50	Costs divided 4 ways.
MAT-90080:MAT:Conduit :Conduit: 1 1/2" HDPE SDR-11	\$ 89,267.20	\$ 44,633.60	Cost divided via pro-rata
Total Relocation Cost	\$ 723,085.20	\$ 351,721.35	

Fort Bend County Reimbursement (50%)

\$ 175,860.68

Exhibit C

CyrusOne Schedule of Work and Estimated Dates of Completion.

(As Shown Below)

Construction Schedule:

Begin Construction: March 28, 2015

Complete Construction: May 16, 2016

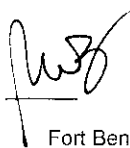
 3/30/16
Date
Fort Bend County

 3/29/16
Initial Date
CyrusOne

CERTIFICATE OF INTERESTED PARTIES

FORM 1295

1 of 1

Complete Nos. 1 - 4 and 6 if there are interested parties.
Complete Nos. 1, 2, 3, 5, and 6 if there are no interested parties.

OFFICE USE ONLY CERTIFICATION OF FILING

1 Name of business entity filing form, and the city, state and country of the business entity's place of business.

CyrusOne, LLC
Carrollton, TX United States

Certificate Number:
2016-32410

Date Filed:
03/29/2016

2 Name of governmental entity or state agency that is a party to the contract for which the form is being filed.

Fort Bend County

Date Acknowledged:

3 Provide the identification number used by the governmental entity or state agency to track or identify the contract, and provide a description of the goods or services to be provided under the contract.

23381
23381 - 1/5/16 Utility Relication FM 1093 Westpark Mobility Bond Project no. 748

4	Name of Interested Party	City, State, Country (place of business)	Nature of interest (check applicable)	
			Controlling	Intermediary

5 Check only if there is NO Interested Party.

6 AFFIDAVIT

I swear, or affirm, under penalty of perjury, that the above disclosure is true and correct.

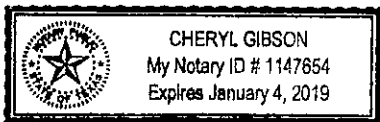

Gregory Andrews
Signature of authorized agent of contracting business entity

AFFIX NOTARY STAMP / SEAL ABOVE

Sworn to and subscribed before me, by the said Gregory Andrews, this the 30th day of March, 2016, to certify which, witness my hand and seal of office.

Cheryl Gibson Signature of officer administering oath
Cheryl Gibson Printed name of officer administering oath
Notary Title of officer administering oath

Chapter 46. Disclosure of Interested Parties
(effective December 24, 2015)
Text of Adopted Rule

The adopted new language is indicated by underlined text.

Chapter 46. DISCLOSURE OF INTERESTED PARTIES

§46.1. Application

(a) This chapter applies to section 2252.908 of the Government Code.

(b) Section 2252.908 of the Government Code applies only to a contract of a governmental entity or state agency entered into after December 31, 2015, that meets either of the following conditions:

(1) The contract requires an action or vote by the governing body of the entity or agency; or

(2) The value of the contract is at least \$1 million.

(c) A contract does not require an action or vote by the governing body of a governmental entity or state agency if:

(1) The governing body has legal authority to delegate to its staff the authority to execute the contract;

(2) The governing body has delegated to its staff the authority to execute the contract; and

(3) The governing body does not participate in the selection of the business entity with which the contract is entered into.

§46.3. Definitions

(a) "Contract" includes an amended, extended, or renewed contract.

(b) "Business entity" includes an entity through which business is conducted with a governmental entity or state agency, regardless of whether the entity is a for-profit or nonprofit entity. The term does not include a governmental entity or state agency.

(c) "Controlling interest" means: (1) an ownership interest or participating interest in a business entity by virtue of units, percentage, shares, stock, or otherwise that exceeds 10 percent; (2) membership on the board of directors or other governing body of a business entity of which the board or other governing body is composed of not more than 10 members; or (3) service as an officer of a business entity that has four or fewer officers, or service as one of the four officers most highly compensated by a business entity that has more than four officers.

(d) "Interested party" means: (1) a person who has a controlling interest in a business entity with whom a governmental entity or state agency contracts; or (2) a person who actively participates in facilitating a contract or negotiating the terms of a contract with a governmental entity or state agency, including a broker, intermediary, adviser, or attorney for the business entity.

(e) "Intermediary," for purposes of this rule, means, a person who actively participates in the facilitation of the contract or negotiating the contract, including a broker, adviser, attorney, or representative of or agent for the business entity who:

(1) receives compensation from the business entity for the person's participation;

(2) communicates directly with the governmental entity or state agency on behalf of the business entity regarding the contract; and

(3) is not an employee of the business entity.

§46.5. Disclosure of Interested Parties Form

(a) A disclosure of interested parties form required by section 2252.908 of the Government Code must be filed on an electronic form prescribed by the commission that contains the following:

(1) The name of the business entity filing the form and the city, state, and country of the business entity's place of business;

(2) The name of the governmental entity or state agency that is a party to the contract for which the form is being filed;

(3) The name of each interested party and the city, state, and country of the place of business of each interested party;

(4) The identification number used by the governmental entity or state agency to track or identify the contract for which the form is being filed and a short description of the goods or services used by the governmental entity or state agency provided under the contract; and

(5) An indication of whether each interested party has a controlling interest in the business entity, is an intermediary in the contract for which the disclosure is being filed, or both.

(b) The certification of filing and the completed disclosure of interested parties form generated by the commission's electronic filing application must be printed, signed by an authorized agent of the contracting business entity, and submitted to the governmental entity or state agency that is the party to the contract for which the form is being filed

(c) A governmental entity or state agency that receives a completed disclosure of interested parties form and certification of filing shall notify the commission, in an electronic format prescribed by the commission, of the receipt of those documents not later than the 30th day after the date the contract for which the form was filed binds all parties to the contract.

(d) The commission shall make each disclosure of interested parties form filed with the commission under section 2252.908(f) of the Government Code available to the public on the commission's Internet website not later than the seventh business day after the date the commission receives the notice required under subsection (c) of this section.