

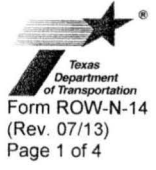

Notice of Confidentiality Rights: If you are a natural person, you may remove or strike any of the following information from this instrument before it is filed for record in the public records: your Social Security Number or your Driver's License Number.



DEED

TxDOT ROW CSJ: 00027-08-175

TxDOT Parcel No.: 2

Grantor(s), whether one or more:

FORT BEND COUNTY DRAINAGE DISTRICT

Grantor's Mailing Address (including county):

**301 Jackson Street, Room 101
Richmond, TX 77469
(Fort Bend County)**

Grantee:

The State of Texas, acting by and through the Texas Transportation Commission

Grantee's Authority:

The Texas Transportation Commission is authorized under the Texas Transportation Code to purchase land and such other property rights (including requesting that counties and municipalities acquire highway right of way) deemed necessary or convenient to a state highway or turnpike project to be constructed, reconstructed, maintained, widened, straightened, or extended, or to accomplish any purpose related to the location, construction, improvement, maintenance, beautification, preservation, or operation of a state highway or turnpike project.

The Texas Transportation Commission is also authorized under the Texas Transportation Code, Chapter 203 to acquire or request to be acquired such other property rights deemed necessary or convenient for the purposes of operating a state highway or turnpike project, with control of access as necessary to facilitate the flow of traffic and promote the public safety and welfare on both non-controlled facilities and designated controlled access highways and turnpike projects.

Grantee's Mailing Address (including county):

Texas Department of Transportation
125 E. 11th Street
Travis County
Austin, Texas 78701



Consideration:

The sum of EIGHT THOUSAND EIGHT HUNDRED EIGHTY and no/100 Dollars (\$8,880.00) to Grantor in hand paid by Grantee, receipt of which is hereby acknowledged, and for which no lien is retained, either expressed or implied.

Property:

All of that certain tract or parcel of land in Fort Bend County, Texas, being more particularly described in the attached Exhibit A (the "**Property**").

Reservations from and Exceptions to Conveyance and Warranty:

This conveyance is made by Grantor and accepted by Grantee subject to the following:

1. Visible and apparent easements not appearing of record.
2. Any discrepancies, conflicts, or shortages in area or boundary lines or any encroachments or any overlapping of improvements which a current survey would show.
3. Easements, restrictions, reservations, covenants, conditions, oil and gas leases, mineral severances, and encumbrances for taxes and assessments (other than liens and conveyances) presently of record in the Official Public Records of Fort Bend County, Texas, that affect the property, but only to the extent that said items are still valid and in force and effect at this time.

Grantor reserves all of the oil, gas, sulfur in and under the Property but waives all rights of ingress and egress to the surface thereof for the purpose of exploring, developing, mining or drilling for same; however, nothing in this reservation shall affect the title and rights of the Grantee, its successors and assigns, to take and use all other minerals and materials thereon, therein and thereunder.

Grantor is retaining title to the following improvements ("**Retained Improvements**") located on the Property, to wit: **NONE**

Access on and off Grantor's remaining property to and from the State highway facility shall be permitted except to the extent that such access is expressly prohibited by the provisions set out in Exhibit "A". Grantor acknowledges that such access on and off the State highway facility is subject to regulation as may be determined by the Texas Department of Transportation to be necessary in the interest of public safety or by applicable local municipal or county zoning, platting or permitting requirements.

GRANTOR, for the Consideration and subject to the Reservations from Conveyance and the Exceptions to Conveyance and Warranty, grants, sells and conveys to Grantee the Property, together with all and singular the rights and appurtenances thereto in anywise belonging, to have and to hold it to Grantee and Grantee's successors and assigns forever. Grantor binds Grantor and Grantor's heirs, successors and assigns to Warrant and Forever Defend all and singular the Property to Grantee and Grantee's successors and assigns against every person whomsoever lawfully claiming or to the claim the same or any part thereof, except as to the Reservations from Conveyance and the Exceptions to Conveyance and Warranty.

EXECUTED on the date(s) of acknowledgement indicated below.

GRANTOR:

FORT BEND COUNTY DRAINAGE DISTRICT

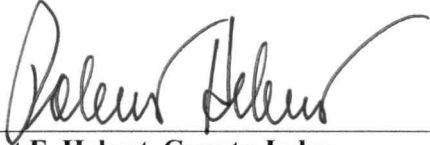

By: **Robert E. Hebert, County Judge**

Corporate Acknowledgment

State of Texas §
 §
County of Fort Bend §

This instrument was acknowledged before me on the 28th day of June, 2016,
by **Robert E. Hebert, County Judge**, on behalf of the **Fort Bend County Drainage District**.

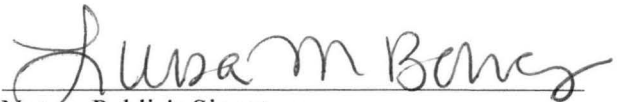
Notary Public's Signature

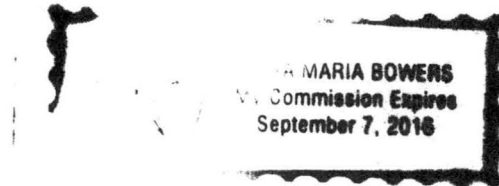
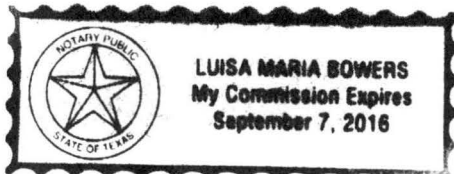

EXHIBIT A

County: Fort Bend
Highway Designation: US 90A
Project Limits: From SH 6 to SH 99
RCSJ: 0027-08-175

PROPERTY DESCRIPTION FOR PARCEL 2

Being a 0.1274 acre (5,550 square feet) parcel of land situated in the Mills M. Battle Survey, Abstract Number 9, Fort Bend County, Texas and being part of a called 4.1696 acres tract (being a called 4.2917 acre tract less and except a called 0.1221 acre tract recorded in F.B.C.C.F. NUMBER 9635401) dedicated from Lexington Development, Co. to the Fort Bend County Drainage District recorded in Slide Number 1021A of the Plat Records of Fort Bend County, Texas, (P.R.F.B.C.), said 0.1274 acre parcel of land being more particularly described as follows:

COMMENCING at a found 5/8-inch iron rod with cap stamped "COTTON" found for the northwestern most corner of said residue of a called 4.2917 acres tract, and the northeastern most corner of a called 1.6994 acres tract of land conveyed in special warranty deed to BAY AREA AND HIGHWAY THREE, INC. and recorded in F.B.C.C.F. NUMBER 9536956, and being on the existing southeast right-of-way line of U.S. Highway 90A (a variable width right-of-way);

THENCE, North 65° 40' 55" East, with said existing southeast right-of-way line of said U.S. Highway 90A and the northwest line of said residue of 4.2917-acres tract, a distance of 114.61 feet to a set 5/8-inch iron rod with TxDOT aluminum cap for corner on the proposed southeast right-of-way line of U.S. Highway 90A (a variable width right-of-way), said point being the **POINT OF BEGINNING** of the parcel herein described, having coordinates of N=13,785,137.79 E=3,028,956.77; **

- 1) **THENCE**, North 65° 40' 55" East, with the northwest line of said NEW TERRITORY RETAIL CENTER ONE and with the existing southeast right-of-way line of said U.S. Highway 90A, being the northwesterly line of said residue of called 4.2917 acres tract, a distance of 443.79 feet to a 5/8-inch iron rod with TxDOT aluminum cap set for the northeastern most corner of this tract;**
- 2) **THENCE**, South 24° 20' 17" East, over and across said residue-of-4.2917-acres and with the proposed southeast right-of-way line of said U.S. Highway 90A., a distance of 14.78 feet to a 5/8-inch iron rod with TxDOT aluminum cap the southeastern most corner of this tract;**
- 3) **THENCE**, South 65° 42' 24" West, over and across said residue of 4.2917-acres tract and with the proposed southeast right-of-way line of said U.S. Highway 90A, a distance of 311.18 feet to set 5/8-inch iron rod with TxDOT aluminum cap for an angle point; **

EXHIBIT A

- 4) **THENCE**, South 71° 59' 02" West, over and across said residue of 4.2917-acres tract and with the proposed southeast right-of-way line of said U.S. Highway 90A, a distance of 133.43 feet to the **POINT OF BEGINNING** and containing 0.1274 acre (5,550 square feet) of land.

EXHIBIT A

Notes:

1. All bearings and coordinates shown hereon are based on the Texas Coordinate System, South Central Zone (4204), North American Datum of 1983(NAD83), 1993 Adjustment.
2. Coordinates and distances are US survey feet, displayed in surface values and may be converted to grid by dividing by the combined adjustment factor of 1.00013.
3. Horizontal control values are based on holding the published values for monuments: H1, H2, H4, H5, H6, H7, H8, H9, H10 and N0800018.
4. ** The monument described and set in this call may be replaced with a TxDOT Type II right-of-way marker upon the completion of the highway construction project under the supervision of a Registered Professional Land Surveyor, either employed or retained by TxDOT.
5. Proposed right-of-way baseline may not match proposed construction baseline or as-built baseline due to design changes.
6. Abstracting completed on TBD
7. Field surveys completed on TBD
8. A parcel plat of even date was prepared in conjunction with this property description.
9. Access will be permitted to the remainder property abutting the highway facility

I, Ronny "Lee" Lackey, Jr., a Registered Professional Land Surveyor, hereby certify that the property description hereon and the accompanying parcel plat of even date represent an actual survey made on the ground under my supervision.

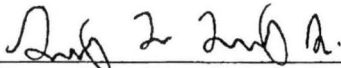

Ronny "Lee" Lackey, Jr.
Registered Professional Land Surveyor
Texas No. 6440
Halff Associates, Inc.
14800 St. Mary's Lane, Suite 160
Houston, Texas 77079-2943
Tel (713) 588-2450
Fax (281) 310-5259
TBPLS Firm No. 10029606

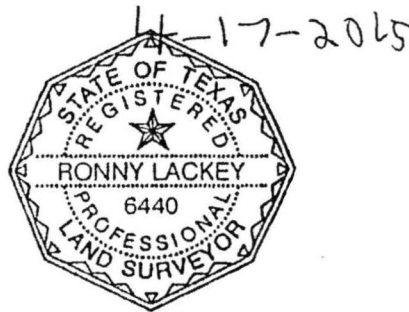

April 2015

MILLS M. BATTLE SURVEY
ABSTRACT NUMBER 9

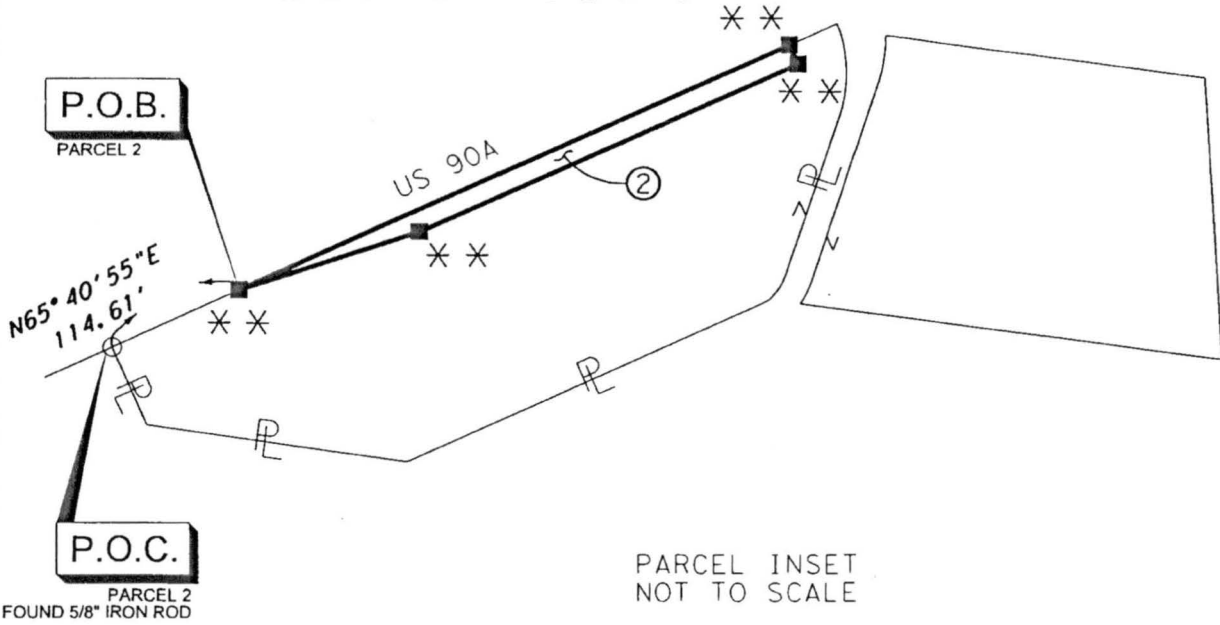

W_IR4225_MON_FS_FW.plt

Sheet

4/17/2015 10:01:36 AM ah2753 TXDOT \\126000a\58931\WAD\CAD\Sheets\Parcel Sheets\0027-08-175_S02A_PP.dgn

PARCEL INSET
NOT TO SCALE

LEGEND

- COLN— COUNTY LINE
- S— SURVEY LINE
- P— PROPERTY LINE
- SET 5/8" IRON ROD WITH TxDOT ALUMINUM CAP
- FOUND 5/8" IRON ROD WITH TxDOT ALUMINUM CAP
- FOUND IRON ROD (AS INDICATED)
- △ TxDOT CONTROL MONUMENT
- ⊙ PARCEL NUMBER
- ⊙ SIGN
- Pipeline Marker
- P.R.F.B.C. PLAT RECORDS OF FORT BEND COUNTY
- F.B.C.C.F. FORT BEND COUNTY CLERK'S FILE
- F.B.C.A.D. FORT BEND COUNTY APPRAISAL DISTRICT
- R.O.W. RIGHT OF WAY

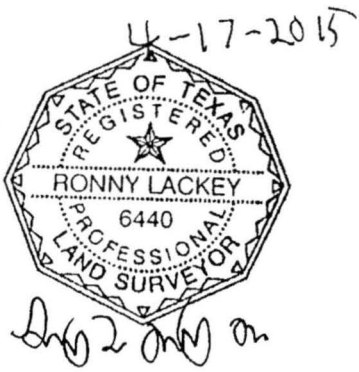

REVISIONS:

--	--	--

NOTES:

1. ALL BEARINGS AND COORDINATES SHOWN HEREON ARE BASED ON THE TEXAS COORDINATE SYSTEM, SOUTH CENTRAL ZONE (4204), NORTH AMERICAN DATUM OF 1983 (NAD83), 1996 ADJUSTMENT.
2. COORDINATES AND DISTANCES ARE US SURVEY FEET, DISPLAYED IN SURFACE VALUES AND MAY BE CONVERTED TO GRID BY DIVIDING BY THE TxDOT SURFACE ADJUSTMENT FACTOR OF 1.00013.
3. HORIZONTAL CONTROL VALUES ARE BASED ON HOLDING THE PUBLISHED VALUES FOR MONUMENTS: H1, H2, H4, H5, H6, H7, H8, H9, H10 AND N0800018.
4. THE MONUMENT DESCRIBED AND SET MAY BE SET AND REPLACED WITH A TxDOT TYPE II RIGHT-OF-WAY MARKER UPON COMPLETION OF THE HIGHWAY CONSTRUCTION PROJECT UNDER THE SUPERVISION OF A REGISTERED PROFESSIONAL LAND SURVEYOR, EITHER EMPLOYED OR RETAINED BY TxDOT.
5. PROPOSED RIGHT-OF-WAY BASELINE MAY NOT MATCH PROPOSED CONSTRUCTION BASELINE OR AS-BUILT BASELINE DUE TO DESIGN CHANGES.
6. RIGHT-OF-WAY MAP COMPLETED ON APRIL, 2015.
7. ABSTRACTING COMPLETED ON JANUARY, 2015.
8. FIELD SURVEYS COMPLETED ON FEBRUARY, 2015.
9. ACCESS WILL BE PERMITTED TO THE REMAINDER PROPERTY ABUTTING THE HIGHWAY FACILITY.

EXISTING ACRES	TAKING AC. (SQ. FT.)	REMAINING ACRES
CALLED 4.1696 AC.	0.1274 AC. (5,550 SQ. FT.)	4.0422 L

HALFF
TBPLS FIRM# 10029606
TBPE FIRM# F-312
14800 ST. MARY'S LANE, SUITE 160
HOUSTON, TEXAS 77079-2943
TEL (713) 588-2450
FAX (281) 310-5259

PARCEL PLAT
SHOWING
PARCEL 2

US 90A FORT BEND COUNTY
RCSJ: 0027-08-175
APRIL, 2015
PAGE 4 OF 5 SCALE: NOT TO SCALE

MILLS M. BATTLE SURVEY
ABSTRACT NUMBER 9

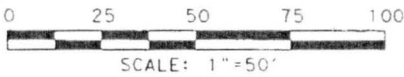
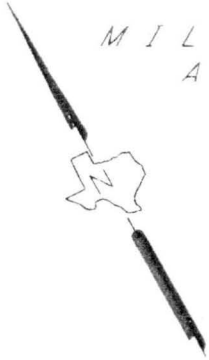

W:\R4225-MON_ES_FW.plt

Sheet

4/17/2015 10:31:56 AM R12753 TXD00 \12800c\2893\1\WAO6\CADD\Sheet\Parcel Sheets\0027-08-175_502B_PP.dgn

STA: 482+33.00
OFFSET: 163.81'L

STA: 482+33.00
OFFSET: 149.03'L

S24°20'17"E
14.78'

S65°39'55"W 4,692.91'

EXISTING R.O.W.

30' MAINTENANCE BERM AREA
SLIDE NUMBER 1021A P.R.F.B.C.

US 90A
STATE OF TEXAS
VOL. 201, PG. 468 D.R.F.B.C.
485+00

②

N65°40'55"E 443.79'

S65°42'24"W 311.18'

RESIDUE OF
CALLED 4.2917 ACRES
FORT BEND COUNTY
DRAINAGE DISTRICT
SLIDE NUMBER 1021A, P.R.F.B.C.
RECORDED DATE: DECEMBER 11, 1989
F.B.C.A.D. NUMBER R146532

(PROPOSED WEST
BOUND BASELINE)
(NOT TO SCALE)

PROPOSED R.O.W.

REVISIONS:

STA: 485+44.18
OFFSET: 163.59' L

**P.O.B.
PARCEL 2**

N: 13,785,137.79
E: 3,028,956.77

STA: 486+76.79
OFFSET: 148.90' L

CALLLED
1.6994 ACRES
BAY AREA AND
HIGHWAY THREE, INC.
RECORDED:
JULY 3, 1995
F.B.C.C.F. NUMBER
9536956
F.B.C.A.D. NUMBER
R210997

25' BUILDING LINE
SLIDE NUMBER 1021A P.R.F.B.C.
20' MAINTENANCE BERM AREA
SLIDE NUMBER 1021A P.R.F.B.C.

N65°40'55"E
114.61'

**P.O.C.
PARCEL 2**

FOUND 5/8"
IRON ROD W/ CAP
STAMPED 'COTTON'



HALFF

TRPLS FIRM# 10029606
TRPE FIRM# F-312
14800 ST. MARY'S LANE, SUITE 160
HOUSTON, TEXAS 77079-2943
TEL (713) 588-2450
FAX (281) 310-5259

PARCEL PLAT
SHOWING
PARCEL 2

US 90A

FORT BEND COUNTY

RCSJ: 0027-08-175
APRIL, 2015

PAGE 5 OF 5

SCALE: 1"=50'

For Comptroller's use only

Application for Texas Identification Number

• See instructions on back

1. Is this a new account? YES Mail Code 000 NO Enter Mail Code 0 0 0 Agency number 6 0 1
 Complete Sections 1 - 5 Complete Sections 1, 2 & 5

Section 1

2. Texas Identification Number (TIN) - Indicate the type of number you are providing to be used for your TIN

Employer Identification Number (EIN) (9 digits)

Social Security number (SSN) (9 digits) Enter the number indicated _____

Individual Taxpayer Identification Number (ITIN) (9 digits)

Comptroller's assigned number (FOR STATE AGENCY USE ONLY) (11 digits)

Current Texas Identification Number (FOR STATE AGENCY USE ONLY) (11 digits)

3. Are you currently reporting any Texas tax to the Comptroller's office such as sales tax or franchise tax? YES NO If "YES," enter Texas Taxpayer Number _____

Section 2

Payee Information (Please type or print)

4. Name of payee (Individual or business to be paid)
Fort Bend County Drainage District; & Charter Title Company

5. Mailing address where you want to receive payments
4265 San Felipe, Suite 350

6. (Optional) _____

7. (Optional) _____

8. (Optional) _____

9. City **Houston** State **T X** ZIP Code **7 7 0 2 7 - 0 0 0 0**

10. Payee telephone number (Area code and number) (_____) _____ SIC code _____ Security type code (0, 1, 2) _____ Zone code _____

Section 3

11. Ownership Codes - Check only one code by the appropriate ownership type that applies to you or your business.

I - Individual Recipient (not owning a business)

S - Sole Ownership (Individual owning a business): If checked, enter the owner's name and Social Security number (SSN)
 Owner's name _____
 SSN / ITIN (9 digits) _____

P - Partnership: If checked, enter two partner's names and Social Security numbers (SSN). If a partner is a corporation, use the corporation's Employer Identification Number (EIN).
 Name _____
 SSN / ITIN / EIN (9 digits) _____
 Name _____
 SSN / ITIN / EIN (9 digits) _____

L - Texas Limited Partnership: If checked, enter the Texas File Number _____

T - Texas Corporation: If checked, enter the Texas File Number _____

A - Professional Association: If checked, enter the Texas File Number _____

C - Professional Corporation: If checked, enter the Texas File Number _____

O - Out-of-State Corporation

G - Governmental Entity

U - State agency / University

F - Financial Institution

R - Foreign (out of U.S.A.)

N - Other: If checked, explain. _____

Section 4

12. Payment Assignment? YES NO Note: A copy of the assignment agreement between payees must be attached.

Assignee name _____

Assignee TIN _____ Assignment date _____

Section 5

13. Comments **ROW CSJ: 0027-08-175 Parcel 2**

14. **sign here** _____ Date _____
 Authorized signature (Applicant or authorized agent)

15. Agency name **TxDot** Prepared by **Paul Heidaker** Phone (Area code and number) **281-994-4120**

RETURN AT COUNTER:

FORT BEND COUNTY ADMIN SERV COORD-
RENEE

FILED AND RECORDED
OFFICIAL PUBLIC RECORDS

Laura Richard



Laura Richard, County Clerk
Fort Bend County, Texas

July 01, 2016 08:20:29 AM

FEE: \$0.00 SR1
DEED

2016069798