

**JOINT PROJECT AGREEMENT REGARDING ROAD RIGHT-OF-WAY
AND RELATED CONSTRUCTION**

This Joint Project Agreement Regarding Road Right-of-Way and Related Construction (this "Agreement") is effective as of the 17th day of December, 2014 (the "Effective Date") by and between Fort Bend County Municipal Utility District No. 133 (the "District"), a conservation and reclamation district and a body politic and a political subdivision of the State of Texas, and Fort Bend County Toll Road Authority (the "Authority"), a local government corporation created by Fort Bend County, Texas (the "County") pursuant to Chapter 431 of the Texas Transportation Code, (collectively, the "Parties" or individually, a "Party").

RECITALS

WHEREAS, the County in conjunction with the Texas Department of Transportation ("TxDOT") and the Authority plans to improve and expand FM 1093 as part of the Westpark Tollway ("FM 1093 Expansion"), including a portion located within the boundaries of the District; and

WHEREAS, the Parties desire to coordinate and allocate responsibility for the design, construction, and right-of-way acquisition of the frontage road associated with the FM 1093 Expansion adjacent to the District as shown on **Exhibit A**, attached hereto, ("Frontage Road"); and

WHEREAS, Tanoureen, Ltd. and L.O.B. Limited Partnership (the "Developers") currently own or are expected to own the land described in **Exhibit B**, attached hereto, (the "Land") and have agreed to convey the Land to the District for use as road right-of-way; and

WHEREAS, the County created Fort Bend County Assistance District No. 1 ("FBCAD No. 1") and FBCAD No. 1 imposes a 1% sales and use tax within the boundaries of FBCAD No. 1, which includes certain areas within the District, and the sales tax receipts collected can be used for, among other things, the design, construction, and financing of frontage roads and access roads for the Westpark Tollway and connecting roadways; and

WHEREAS, the District entered into a Strategic Partnership Agreement (the "SPA") with the City of Houston, Texas (the "City"), dated November 16, 2012, which may be amended from time to time, under which the City annexed certain areas within the District into the City for limited purposes (the "Limited Purpose Annexation Area") and imposes its 1% sales and use tax within the Limited Purpose Annexation Area and remits one-half of its sales tax receipts collected within the Limited Purpose Annexation Area to the District; and

WHEREAS, the Frontage Road will also facilitate the development of commercial property in the County and the District, thereby expanding their tax bases; and

WHEREAS, the Parties have read and understood the terms and provisions set forth in this Agreement, and have been afforded a reasonable opportunity to review this Agreement with their respective legal counsel.

NOW, THEREFORE, in consideration of the premises and mutual promises, covenants, obligations, and benefits contained herein, the Parties agree as follows:

AGREEMENT

1. The Authority, at its cost, shall design and construct the Frontage Road, including the entrance and exit ramps to the Westpark Tollway at the locations shown on **Exhibit A**. The Authority will use all commercially reasonable efforts to cause the Frontage Road to be prioritized in the construction sequencing.

2. The District will acquire, at its cost, from the Developers fee title to the Land by special warranty deed. In addition, the District will acquire, at its cost, from the Developers by quitclaim deed any interest the Developers may have in the land that was conveyed to the Metropolitan Transit Authority of Harris County, Texas, by instrument dated December 30, 1992, and recorded in the Official Public Records of Fort Bend County in Volume 2478, Page 1664, and under Clerk's File No. 9277986 from Grand Parkway to F.M. 723 (the "Other Land"). The District agrees to allow the construction of the Frontage Road on the Land. In consideration of the Authority's obligations hereunder, and in a form acceptable to the District, the District shall execute in favor of the Authority: (i) a special warranty deed conveying fee title to the Land, and (ii) a quitclaim deed quitclaiming any interest the District may have in the Other Land. The District shall execute same within 60 days of the Authority's written request for same, and the Authority shall request same no earlier than March 15, 2015 and no later than December 31, 2015.

- a. The Parties agree that, other than for Katy Gaston Road, access to the Frontage Road from the property adjacent and south of the Land shall be denied, except for the following (collectively, the "New Roadway Connections"): (1) not more than one public road and four public or private roadway connections are allowed west of Katy Gaston Road; and (2) not more than three public or private roadway connections are allowed east of Katy Gaston Road. The permitted locations of the New Roadway Connections are shown on **Exhibit A** but may be relocated provided a new location meets all County and TxDOT criteria and is approved by the Authority,

which approval shall not be unreasonably withheld or delayed. The District may eliminate any of the New Roadway Connections by providing written notice to the Authority. At the District's request, if made prior to January 15, 2015, the Authority shall include within its construction contract for the Westpark Tollway and construct at the Authority's expense the deceleration lanes and driveway/roadway stub outs up to the southern property line of the Land for those New Roadway Connections the District selects (collectively, the "Authority Constructed Connections"). The Parties agree that the three roadway connections at the locations shown on **Exhibit A** east of Katy Gaston Road are included in the Authority Constructed Connections. Prior to January 15, 2015, the District will provide geometric configurations for the design and width of all of the Authority Constructed Connections. The District shall reimburse the Authority for one-third of the engineering and construction cost for the Authority Constructed Connections solely and exclusively from sales tax revenue the District receives from the City under the SPA. The Authority shall seek reimbursement for the remaining two-thirds from sales tax revenue from FBCAD No. 1. Construction of deceleration lanes and driveway/roadway stub outs for any New Roadway Connections not selected by the District for construction as part of the Westpark Tollway project (collectively, the "District Constructed Connections") will be at the District's expense; provided, however, the District shall be reimbursed by FBCAD No. 1 using sales tax revenue from FBCAD No. 1 for two-thirds of the engineering and construction cost for the District Constructed Connections. A Party requesting reimbursement under this provision must submit an itemized statement of costs along with any back-up documentation requested by the reimbursing Party. The reimbursing Party shall have the right to inspect at any reasonable time any documents or other items relating to a requested reimbursement. The District shall be obligated to perform its reimbursement set forth in this paragraph only as, when, if, and to the extent, the District actually receives sales tax revenues. FBCAD No. 1 shall be obligated to perform its reimbursement set forth in this paragraph only as, when, if, and to the extent, FBCAD No. 1 actually receives sales tax revenues.

3. Notwithstanding any provision hereof, the District is not obligated to execute the special warranty deed and quitclaim deed in favor of the Authority and the Authority is not obligated to provide the New Roadway Connections, all as provided in Paragraph 2, until the County, FBCAD No. 1, and the Developers each signs its

respective joinder to this Agreement, attached. Should a Developer (or another entity with substantially the same ownership or control as a Developer) be unable to acquire a portion of the Land that as of the date of this Agreement is not already owned by the Developer, the Developer will provide notice to the District and the Authority of such portion that could not be acquired and, upon receipt of that notice by the District and the Authority, such portion will be excluded from the defined term "Land" for the purposes of this Agreement.

4. The District has or will acquire the existing lakes adjacent to Katy Gaston Road that are located within the Land. The District, at its expense, will modify these lakes so that they are no longer located within the Land.

5. In accordance with the Agreement Regarding METRO License for Katy-Gaston Road Crossing between the County and the District effective February 8, 2011, the District previously caused the construction of Katy-Gaston Rd. and such roadway has been accepted by the County. Whereas such Agreement Regarding METRO License provides for assignment to the County, the Parties agree that the District shall assign to the Authority the License Agreement that the District has with METRO, the Authority shall accept the same, and the Authority shall obtain METRO's consent thereto, all in substantially the form of the Assignment of METRO License Agreement attached as **Exhibit C**. If the County, FBCAD No. 1, and the Developers sign their respective joinders to the Agreement, attached, then such assignment, acceptance, and consent shall occur contemporaneous with the District's execution of the special warranty deed and quitclaim deed described in Paragraph 2; otherwise, such acceptance and consent must occur within 60 days of the Authority's receipt of the form of the Assignment of METRO License Agreement signed by the District.

6. The recitals and all referenced exhibits are incorporated into the Agreement for all purposes.

7. In addition to specific obligations within this Agreement, each Party generally agrees that it will perform such other acts, and execute, acknowledge, and/or deliver such other instruments, documents, and other materials as the other may reasonably request in order to achieve the intentions and objectives of this Agreement.

8. All notices, requests, approvals and other communications required or permitted under this Agreement shall be given in writing and shall be deemed effective (i) upon receipt when delivered by overnight courier or hand delivery, or (ii) two (2) business days after deposit with the US Postal Service, sent certified mail, return receipt requested, postage prepaid, and in each case addressed as follows:

If to the Authority: Fort Bend County Toll Road Authority
c/o The Muller Law Group
16555 Southwest Freeway, Ste. 200

Sugar Land, TX 77479
Attn: Rich Muller

If to the District: Fort Bend County Municipal Utility District No. 133
c/o Allen Boone Humphries Robinson LLP
3200 Southwest Freeway, Suite 2600
Houston, TX 77027
Attn: Alex Garcia

Any Party may designate a different address or manner of delivery by giving at least ten (10) days written notice to the other Parties in the manner provided above.

9. This Agreement together with all referenced exhibits contains the entire agreement between the Parties relating to this Agreement's subject matter and supersedes all prior or contemporaneous agreements, understandings, and commitments between the Parties, whether oral or written, relating to the same. Each Party expressly represents and warrants that no statement, promise, covenant, agreement, warranty, or representation, other than those expressly provided in this Agreement, was made to or relied upon by that Party. This Agreement may only be modified, amended, or terminated in a writing signed by all Parties.

10. This Agreement shall be for the sole and exclusive benefit of the Parties and their successors and assigns and shall not be construed to confer any benefit or right upon any other party, including without limitation any resident of any Party.

11. Nothing in this Agreement shall be deemed or construed as creating the relationship of principal and agent, partnership, or joint venture between the Parties, or a joint enterprise between the Parties and/or any other parties.

12. The failure of any Party to insist, in any one or more instances, upon performance of any terms, covenants, or conditions of this Agreement shall not be construed as a waiver or relinquishment of the future performance of any such term, covenant, or condition, but the obligation with respect to such future performance shall continue in full force and effect.

13. The provisions of this Agreement are severable, and if any provision of this Agreement shall be declared void, illegal, or unenforceable by any court, administrative agency, or other body having valid jurisdiction, the entire Agreement shall not be void; but the remaining provisions shall continue in effect as nearly as possible in accordance with the original intent of the Parties.

14. This Agreement and the obligations of the parties hereunder are subject to all rules, regulations, and laws which may be applicable by the United States, the State of Texas, or any other regulatory agency having jurisdiction. This Agreement, and all

claims arising from or relating to this Agreement, shall be construed, interpreted, and enforced under the laws of the State of Texas, excluding any choice of law rules that would direct the application of the laws of another jurisdiction, and the state courts in Fort Bend County, Texas, shall have exclusive jurisdiction with respect to any disputes arising from or relating to this Agreement.

15. This Agreement may be simultaneously executed in several counterparts, each of which shall be an original and all of which shall be considered fully executed as of the Effective Date of this Agreement, when all Parties have executed an identical counterpart, notwithstanding that all signatures may not appear on the same counterpart.

[EXECUTION PAGES FOLLOW]

JOINDER TO JOINT PROJECT AGREEMENT
REGARDING ROAD RIGHT-OF-WAY AND RELATED CONSTRUCTION

For and in consideration of the benefits of the Joint Project Agreement Regarding Road Right-of-Way and Related Construction (the "Joint Project Agreement"), receipt and sufficiency of which consideration is hereby acknowledged and agreed to, the undersigned hereby acknowledges and agrees that by executing this joinder, (i) it will become and be joined as a party to the Joint Project Agreement, (ii) it is included in the defined terms Party and Parties within the Joint Project Agreement, and (iii) it consents and agrees to the terms of the Joint Project Agreement. For purposes of receiving notices pursuant to Section 8 of the Joint Project Agreement, the undersigned's name and address are as follows.

Fort Bend County Judge
c/o County Judge
301 Jackson Street, Suite 719
Richmond, TX 77469
Attn: Honorable Robert Hebert

ACCEPTED AND AGREED TO this 12th day of May 2015.

FORT BEND COUNTY, TEXAS

By: 
Robert E. Hebert
County Judge

ATTEST:

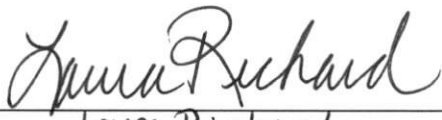
Name: Laura Richard
Title: Fort Bend County Clerk



(SEAL)

JOINDER TO JOINT PROJECT AGREEMENT
REGARDING ROAD RIGHT-OF-WAY AND RELATED CONSTRUCTION

For and in consideration of the benefits of the Joint Project Agreement Regarding Road Right-of-Way and Related Construction (the "Joint Project Agreement"), receipt and sufficiency of which consideration is hereby acknowledged and agreed to, the undersigned hereby acknowledges and agrees that by executing this joinder, (i) it will become and be joined as a party to the Joint Project Agreement, (ii) it is included in the defined terms Party and Parties within the Joint Project Agreement, and (iii) it consents and agrees to the terms of the Joint Project Agreement. For purposes of receiving notices pursuant to Section 8 of the Joint Project Agreement, the undersigned's name and address are as follows.

Fort Bend County Assistance District No. 1
301 Jackson Street
Richmond, TX 77469
Attn: President

ACCEPTED AND AGREED TO this 12th day of May, 2015

FORT BEND COUNTY ASSISTANCE
DISTRICT NO. 1

By: 
Name: Robert E. Hebert, County Judge
Title: Director, County Assistance District

ATTEST:

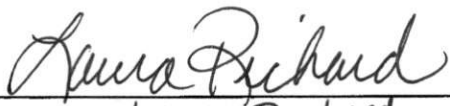
Name: Laura Richard
Title: Fort Bend County Clerk

(SEAL)

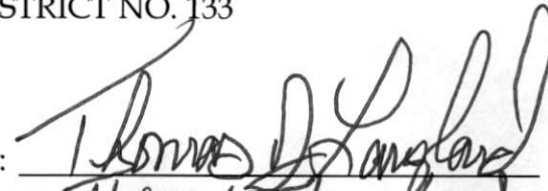

FORT BEND COUNTY MUNICIPAL UTILITY
DISTRICT NO. 133

By: 
Name: Thomas J. Langland
Title: Vice President

ATTEST:

Name: DONNA McClellan
Title: SECRETARY

(SEAL)



FORT BEND COUNTY TOLL ROAD
AUTHORITY

By: 
Name: James Condrey
Title: Chairman

ATTEST:

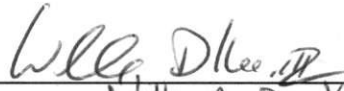
Name: William D. Kee III
Title: Asst. Secretary

(SEAL)



CO.

CAO 1

JOINDER TO JOINT PROJECT AGREEMENT
REGARDING ROAD RIGHT-OF-WAY AND RELATED CONSTRUCTION

For and in consideration of the benefits of the Joint Project Agreement Regarding Road Right-of-Way and Related Construction (the "Joint Project Agreement"), receipt and sufficiency of which consideration is hereby acknowledged and agreed to, the undersigned hereby acknowledges and agrees that by executing this joinder, (i) it will become and be joined as a party to the Joint Project Agreement, (ii) it is included in the defined terms Party and Parties within the Joint Project Agreement, and (iii) it consents and agrees to the terms of the Joint Project Agreement. For purposes of receiving notices pursuant to Section 8 of the Joint Project Agreement, the undersigned's name and address are as follows.

Tanoureen, Ltd.
7500 San Felipe Street, Suite 400
Houston, Texas 77057

ACCEPTED AND AGREED TO this 22nd day of January, 2015

TANOUREEN, LTD.
a Texas limited partnership

By: Tamer, LLC,
a Texas limited liability company
its Sole General Partner

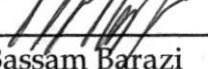
By: 

Bassam Barazi
Member

JOINDER TO JOINT PROJECT AGREEMENT
REGARDING ROAD RIGHT-OF-WAY AND RELATED CONSTRUCTION

For and in consideration of the benefits of the Joint Project Agreement Regarding Road Right-of-Way and Related Construction (the "Joint Project Agreement"), receipt and sufficiency of which consideration is hereby acknowledged and agreed to, the undersigned hereby acknowledges and agrees that by executing this joinder, (i) it will become and be joined as a party to the Joint Project Agreement, (ii) it is included in the defined terms Party and Parties within the Joint Project Agreement, and (iii) it consents and agrees to the terms of the Joint Project Agreement. For purposes of receiving notices pursuant to Section 8 of the Joint Project Agreement, the undersigned's name and address are as follows.

L.O.B. Limited Partnership
7500 San Felipe Street, Suite 400
Houston, Texas 77057

ACCEPTED AND AGREED TO this 22nd day of January, 2015.

L.O.B. LIMITED PARTNERSHIP,
a Texas limited partnership

By: Ryko Development, Inc.,
a Virginia corporation
its Sole General Partner

By: _____



Bassam Barazi
President

EXHIBIT A

EXHIBIT A

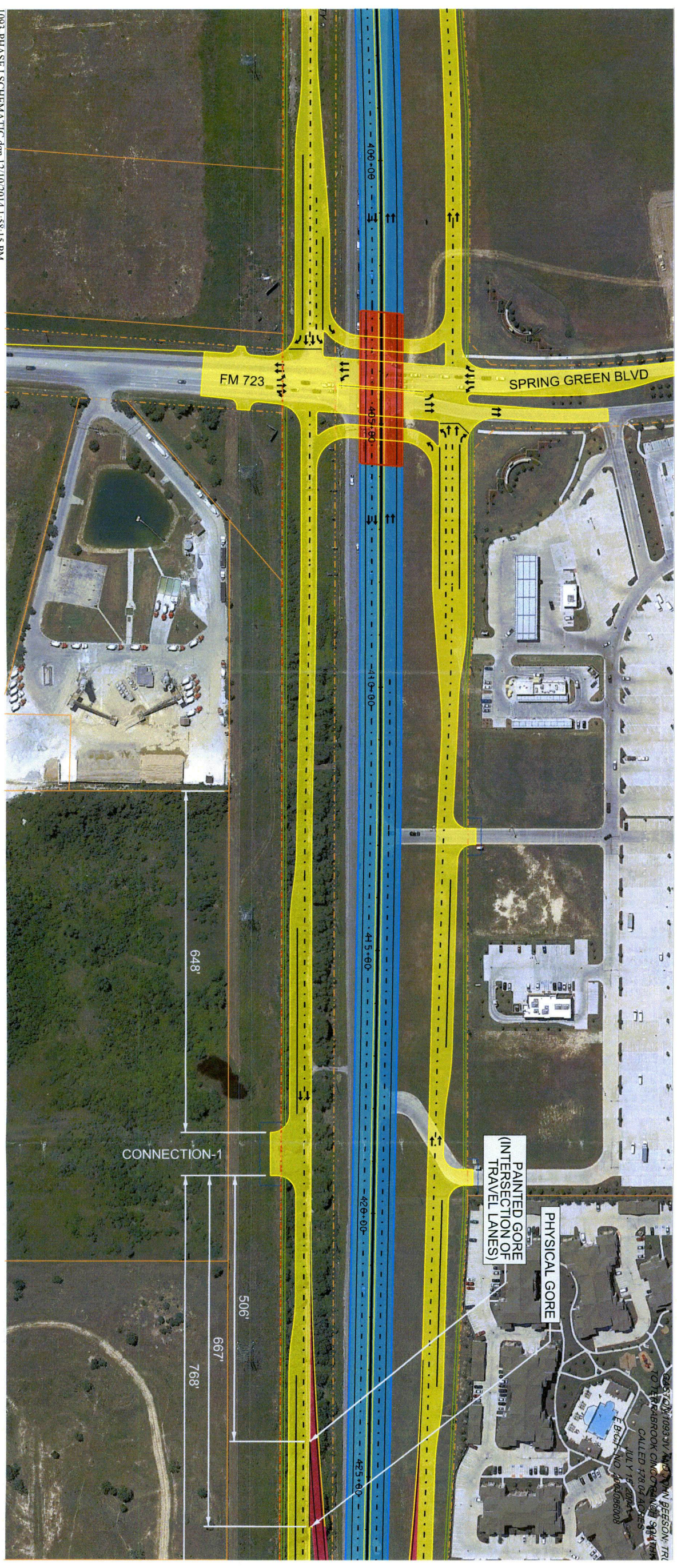
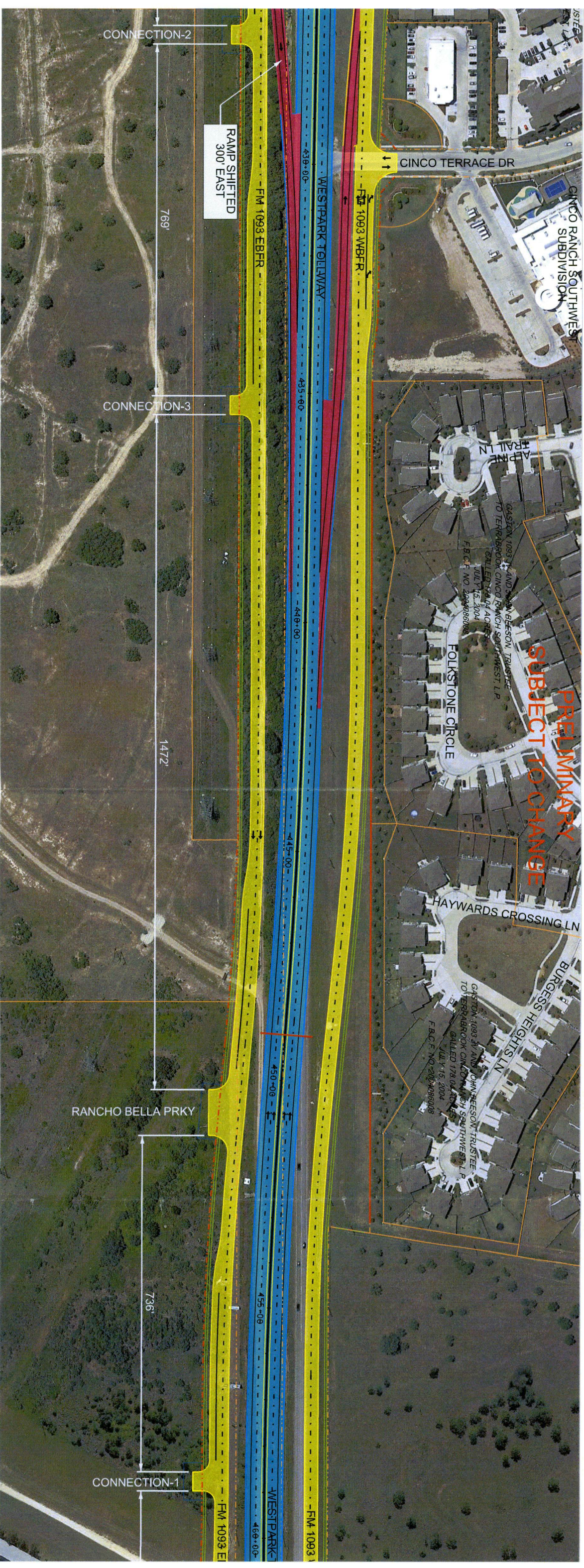

1093-PHASE I SCHEMATIC.dgn 12/10/2014 1:38:15 PM



T

T

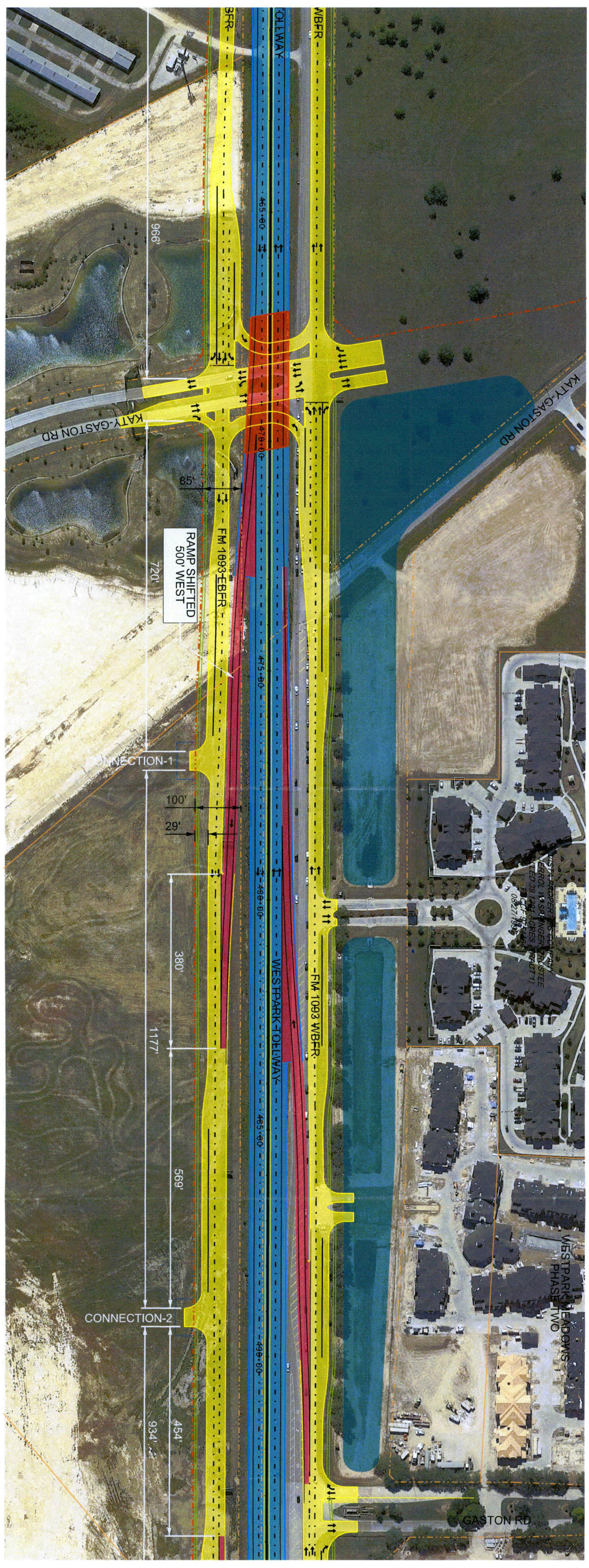



PRELIMINARY
SUBJECT TO CHANGE

EXHIBIT B

EXHIBIT B-1

County: Fort Bend
Highway: F.M. 1093
Project Limits: F.M. 359 to Hwy. 99 (Grand Parkway)

Property Description for Parcel TX-FB-0026.00000

Being a 1.922 acre (83,742 square feet) parcel of land, out of the Joel E. McCrary Survey A-403, Fort Bend County, Texas, and being part of and out of a called 179.7922 acre tract of land, described in Deed from Pacific Richland Investments and Richfield Investment Corporation to L.O.B. Limited Partnership, filed in the Official Public Records of Fort Bend County (O.P.R.F.B.C.) Fort Bend County, Texas, under Clerk's File No. 2005083650, said 1.922 acre tract being more particularly described as follows:

COMMENCING at a 5/8-inch iron rod with cap (stamped "Benchmark Eng") found for a northeast corner of the residue of a called 73.742 acre tract of land, described in a Deed from Lutheran Education Association of Houston to L.O.B. Limited Partnership, filed in the O.P.R.F.B.C. under Clerk's File No. 2007114627, for the south corner of a called 28.267 acre tract of land, described in a Deed from LUED Corporation to L.O.B. Limited Partnership, filed in the O.P.R.F.B.C. under Clerk's File No. 2007068297 and for the northwest corner of said 179.7922 acre tract, thence as follows:

North 42°36'44" East, a distance of 1,543.33 feet, along the northwest line of said 179.7922 acre tract and along the southeast line of said 28.267 acre tract, to a 5/8 inch iron rod with cap (stamped "Weisser Eng., Houston, TX") set for the southwest corner and POINT OF BEGINNING of the herein described parcel;

- 1) THENCE, North 42°36'44" East, a distance of 154.18 feet, along the northwest line of said 179.7922 acre tract, along the southeast line of said 28.267 acre tract and along the northwest line of the herein described parcel, to the existing south right-of-way line of Metropolitan Transit Authority of Harris County, Texas (50 feet wide) as described in Volume 2478, Page 1664 of the Fort Bend County Deed Records (F.B.C.D.R.), Fort Bend County, Texas and filed in the O.P.R.F.B.C. under Clerk's File No. 9277986, to a 5/8 inch iron rod found for the northwest corner of the herein described parcel;
- 2) THENCE, North 83°02'57" East, a distance of 1,169.98 feet, along the south right-of-way line of said Metropolitan Transit Authority of Harris County, Texas and the north line of said 179.7922 acre tract, to a 5/8 inch iron rod found for the east corner of the herein described parcel;

EXHIBIT B-1

- 3) THENCE, South 74°28'39" West, a distance of 182.02 feet, along the proposed south right-of-way of F.M. 1093 (width varies) to a 5/8 inch iron rod with cap (stamped "Weisser Eng., Houston, TX") set for a point in the herein described parcel and the beginning of a curve to the right;
- 4) THENCE, in a southwest direction, with said curve to the right having a radius of 6,524.00 feet, a central angle of 08°34'18" and chord which bears South 78°45'48" West, 975.10 feet, for an arc length of 976.01 feet to a 5/8-inch iron rod with cap stamped "Weisser Eng. Houston, Tx." set in the proposed south right-of-way line of said F.M. 1093 for a point of the herein described parcel;
- 5) THENCE, South 83°02'57" West, a distance of 134.97 feet, along the proposed south right-of-way of F.M. 1093 (width varies), to the POINT OF BEGINNING and containing 1.922 acre (83,742 square feet) parcel of land.

NOTE: The Point of Beginning of this description has coordinates of N=13,817,566.76 and E=2,989,668.05; All bearings are based on the Texas State Plane coordinate system, NAD 83 (1993 Adj.), South Central Zone. All coordinates shown are surface and may be converted to grid by Dividing by TxDOT conversion factor of 1.00013.

NOTE: A parcel plat of even date was prepared in conjunction with this property description.

Compiled by:
Weisser Engineering Company
19500 Park Row, Suite 100
Houston, Texas 77084
December, 2014

CONVENTIONAL SIGNS:

- EXISTING RIGHT-OF-WAY LINE
- ACCESS DENIAL LINE
- PROPOSED RIGHT-OF-WAY LINE
- PROPERTY LINE
- SURVEY LINE

401 DENOTES OWNERSHIP No.

3 DENOTES BEARING AND DISTANCE NOTE No.

- SET 5/8" I.R. W/TxDOT ALUM. CAP (SEE NOTE 2)
- SET 5/8" I.R. W/TxDOT ALUM. CAP (SEE NOTE 3)
- FOUND 5/8" I.R. W/TxDOT ALUM. CAP
- SET (AS INDICATED)
- FOUND (AS INDICATED)

LEGEND:

- = CLERK'S FILE NUMBER
- = FILM CODE NUMBER
- = OFFICIAL RECORDS OF FORT BEND COUNTY
- = FORT BEND COUNTY PLAT RECORDS
- = FORT BEND COUNTY DEED RECORDS
- = FORT BEND COUNTY COURT RECORDS
- = FORT BEND COUNTY DISTRICT COURT RECORDS

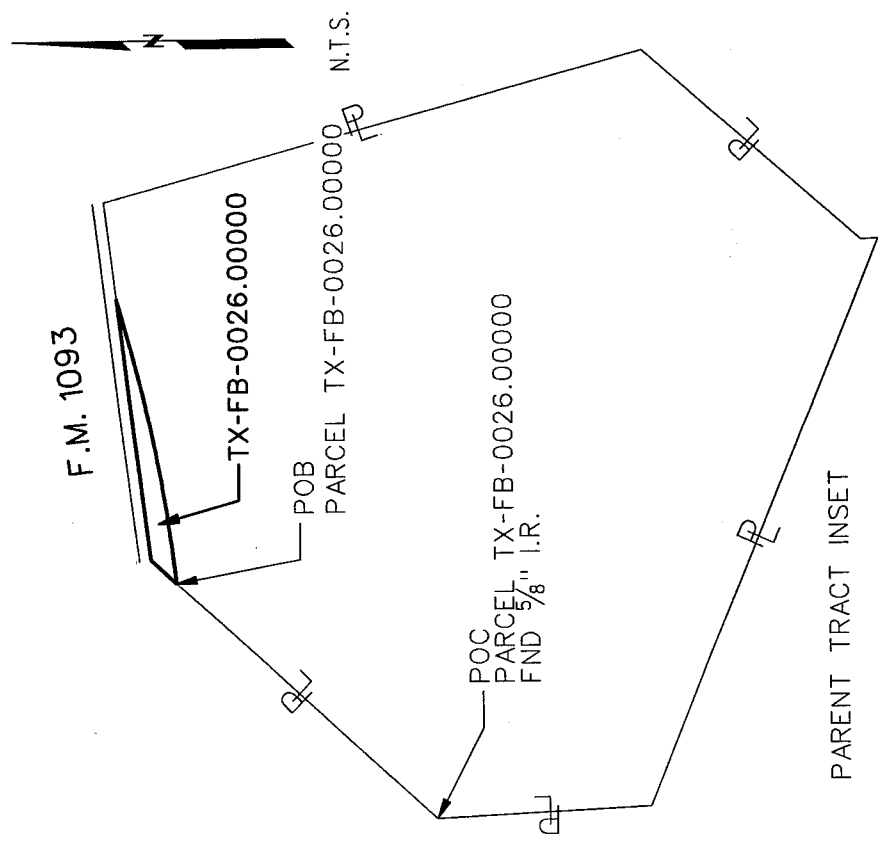

NOTES:

1. A PROPERTY DESCRIPTION OF EVEN DATE WAS PREPARED IN CONJUNCTION WITH THIS PARCEL PLAT.
2. ** THE MONUMENT DESCRIBED AND SET MAY BE REPLACED WITH A TxDOT TYPE II RIGHT-OF-WAY MARKER UPON COMPLETION OF THE HIGHWAY CONSTRUCTION PROJECT UNDER THE SUPERVISION OF A REGISTERED PROFESSIONAL LAND SURVEYOR, EITHER EMPLOYED OR RETAINED BY TxDOT.
3. ALL BEARINGS AND COORDINATES ARE BASED ON THE TEXAS COORDINATE SYSTEM, SOUTH CENTRAL ZONE, NAD 83 (1993 ADJ.). ALL DISTANCES AND COORDINATES SHOWN ARE SURFACE AND MAY BE CONVERTED TO GRID BY DIVIDING BY A COMBINED ADJUSTMENT FACTOR OF 1.00013.
4. ABSTRACTING PERFORMED BY: W.E.C. 07/2014.
5. GROUND SURVEY PERFORMED 03/2012 AND 09/2014.

PARENT TRACT INSET

EXISTING	TAKING AC/SF	REMAINING
179.7922 AC	1,922 AC 83,742 SF	177.8702 LT.
19500 Park Row Suite 100 Houston, Texas 77084 (281) 579 - 7300		
PARCEL PLAT SHOWING PARCEL TX-FB-0026.00000 F.M. 1093 FORT BEND COUNTY, TEXAS		
DATE: 09/2014 SCALE: N.T.S. JOB No.: EG676		
RCSJ No.: 1258-03-043 DWG. No.: TX-FB-0026-00000-01		

F.M. 1093

(R.O.W. VARIES)
VOL. 175, PG. 146
VOL. 285, PG. 257
E.B.C.D.R.

497+00

METROPOLITAN TRANSIT
AUTHORITY OF HARRIS
COUNTY, TEXAS
C.F. NO. 9277986
VOL. 2478, PG. 1664
O.P.R.F.B.C.

CALLLED 28.267 ACRES
L.O.B. LIMITED PARTNERSHIP
C.F. NO. 2007068297
DATE: JUNE 4, 2007
O.P.R.F.B.C.

JOEL B. McCLARY
SURVEY, A-703
F.M. 1093
N 42° 36' 14" E
S 83° 02' 57" W
S/O 496+04.55, 164.83' RT

P.O.B.
PARCEL TX-FB-0026.00000
N-13,817,566.76
E- 2,989,668.05
S/O 496+04.55, 164.83' RT

CALLLED 179.7922 ACRES
L.O.B. LIMITED PARTNERSHIP
C.F. NO. 2005083650
DATE: MARCH 8, 2005
O.P.R.F.B.C.

P.O.C.
PARCEL TX-FB-0026.00000
END 5/8" I.R. W/CAP
STAMPED "BENCHMARK ENG"

N 83° 02' 57" E-1,169.98'

EXISTING R.O.W.

END 5/8" I.R. W/CAP
STAMPED "BENCHMARK ENG"

TX-FB-0026.00000

PROPOSED R.O.W.

R- 6,524.00'
D- 08° 34' 18"
L- 976.01'
CH- S 78° 45' 48" W-975.10'
RAD. BRG.- N 15° 31' 21" W

S/O 497+37.86,
168.79' RT

S 83° 02' 57" W-134.97'

SET

SET

SET

SET

SET

SET

SET

SET

SET

SET

MATCH LINE SEE SHEET 5

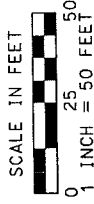

WEISSER Engineering Co.
19500 Park Row, Suite 100
Houston, Texas 77084
(281) 579 - 7300

PARCEL PLAT SHOWING PARCEL TX-FB-0026.00000
F.M. 1093
FORT BEND COUNTY, TEXAS

DATE: 09/20/14 SCALE: 1"= 50' JOB No.: EG676
RCSJ No.: 1258-03-043 DWG. No.: TX-FB-0026-00000-02

F.M. 1093

(R.O.W. VARIES)
VOL. 175, PG. 146
VOL. 285, PG. 257
F.B.C.D.R.

500+00

EXISTING R.O.W.

METROPOLITAN TRANSIT
AUTHORITY OF HARRIS
COUNTY, TEXAS

C.F. NO. 9277986
VOL. 2478, PG. 1664
O.P.R.F.B.C.

N 83° 02' 57" E-1,169.98'

EXISTING R.O.W.

TX-FB-0026.00000

PROPOSED R.O.W.

R= 6,524.00'
D= 08° 34' 18"
L= 976.01'
CH= S 78° 45' 48" W-975.10'
RAD. BRG.= N 15° 31' 21" W

JOEL B. MCGEE, A.S.T.
CALLED 179.7922 ACRES
L.O.B. LIMITED PARTNERSHIP
C.F. NO. 2005083650
DATE: MARCH 8, 2005
O.P.R.F.B.C.

MATCH LINE SEE SHEET 4

MATCH LINE SEE SHEET 6

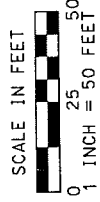

	19500 Park Row, Suite 100 Houston, Texas 77084 (281) 579 - 7300
PARCEL PLAT SHOWING PARCEL TX-FB-0026.00000 F.M. 1093 FORT BEND COUNTY, TEXAS	
DATE: 09/2014	SCALE: 1"= 50'
JOB No.: FG676	
RCSJ No.: 1258-03-043	DWG. No.: TX-FB-0026.00000-03



F.M. 1093
 (R.O.W. VARIES)
 VOL. 175, PG. 146
 VOL. 285, PG. 257
 F.B.C.D.R.

505+00

BASELINE

EXISTING R.O.W.

METROPOLITAN TRANSIT
 AUTHORITY OF HARRIS
 COUNTY TEXAS
 C.F. NO. 9277986
 VOL. 2478, PG. 1664
 O.P.R.F.B.C.

N 83° 02' 57" E-1,169.98'

EXISTING R.O.W.

TX-FB-0026.00000

PROPOSED R.O.W.

R= 6,524.00'
 D= 08° 34' 18"
 L= 976.01'
 CH= S 78° 45' 48" W-975.10'
 RAD. BRG.= N 15° 31' 21" W

S 74° 28' 39" W-182.02'

JOEL B. MCCRARY
 SURVEY, A-402

CALLED 179.7922 ACRES
 L.O.B. LIMITED PARTNERSHIP
 C.F. NO. 2005083650
 DATE: MARCH 8, 2005
 O.P.R.F.B.C.

S/O 507+0337, 161.75' RT

MATCH LINE SEE SHEET 7

MATCH LINE SEE SHEET 5

	19500 Park Row, Suite 100 Houston, Texas 77084 (281) 579 - 7300
	Weisser Engineering Co.
PARCEL PLAT SHOWING PARCEL TX-FB-0026.00000 F.M. 1093 FORT BEND COUNTY, TEXAS	DATE: 09/2014 SCALE: 1"= 50' JOB No.: FG676 RCSI No.: 1258-03-043 DWG. No.: TX-FB-0026.00000-04

MATCH LINE SEE SHEET 6

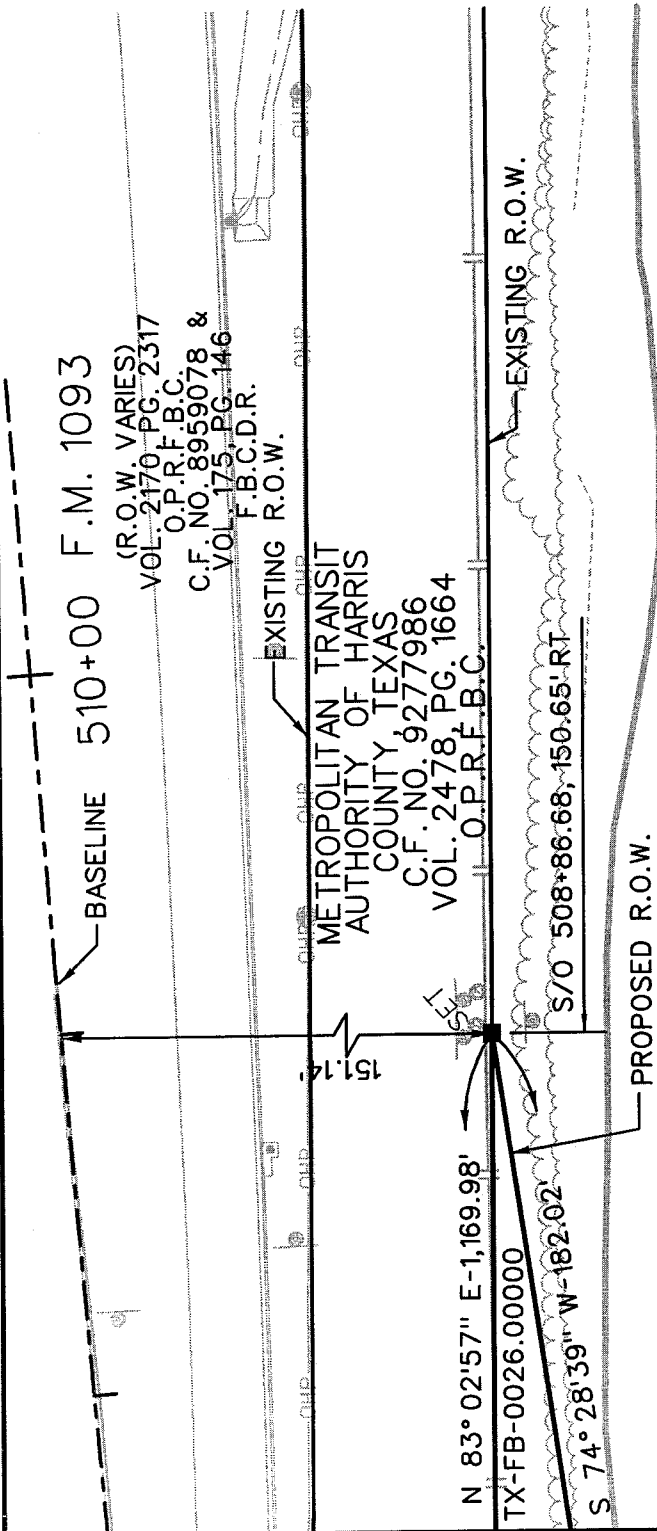

BASELINE 510+00 F.M. 1093
 (R.O.W. VARIES)
 VOL. 2170 PG. 2317
 O.P.R.F.B.C.
 C.F. NO. 8959078 &
 VOL. 175 PG. 146
 F.B.C.D.R.

EXISTING R.O.W.
 METROPOLITAN TRANSIT
 AUTHORITY OF HARRIS
 COUNTY, TEXAS
 C.F. NO. 9277986
 VOL. 2478 PG. 1664
 O.P.R.F.B.C.

N 83° 02'57" E-1,169.98'
 TX-FB-0026.00000
 S 74° 28'39" W-182.02'
 S/O 508+86.68; 150.65' RT
 EXISTING R.O.W.

PROPOSED R.O.W.

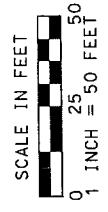

JOEL B. MCCREARY
 SURVEY, A-402

CALLLED 179.7922 ACRES
 L.O.B. LIMITED PARTNERSHIP
 C.F. NO. 2005083650
 DATE: MARCH 8, 2005
 O.P.R.F.B.C.

 WEISSER Engineering Co.	19500 Park Row, Suite 100 Houston, Texas 77084 (281) 579 - 7300
	PARCEL PLAT SHOWING PARCEL TX-FB-0026.00000 F.M. 1093 FORT BEND COUNTY, TEXAS
DATE: 09/2014 SCALE: 1"= 50' JOB No.: FG676 RCSJ No.: 1258-03-043 DWG. No.: TX-FB-0026_00000-05	

EXHIBIT B-2

County: Fort Bend
Highway: F.M. 1093
Project Limits: F.M. 359 to Hwy. 99 (Grand Parkway)

Property Description for Parcel TX-FB-0027.00000

Being a 4.902 acre (213,546 square feet) parcel of land, out of the L.A. Patillo Survey A-307, Fort Bend County, Texas, and being part of and out of a called 28.267 acre tract of land, described in a Deed from LUED Corporation to L.O.B. Limited Partnership, filed in the Official Public Records of Fort Bend County (O.P.R.F.B.C.) Fort Bend County, Texas under Clerk's File No. 2007068297, said 4.902 acre tract being more particularly described as follows:

COMMENCING at a 5/8-inch iron rod with cap (stamped "Benchmark Eng.") found for the east corner of the residue of a called 73.742 acre tract of land, described in a Deed from Lutheran Education Association of Houston to L.O.B. Limited Partnership, filed in the O.P.R.F.B.C. under Clerk's File No. 2007114627, for the west corner of a called 179.7922 acre tract of land, described in Deed from Pacific Richland Investments and Richfield Investment Corporation to L.O.B. Limited Partnership, filed in the O.P.R.F.B.C. under Clerk's File No. 2005083650 and for the south corner of said 28.267 acre tract, thence as follows:

North 42°36'44" East, a distance of 1,543.33 feet, along the northwest line of said 179.7922 acre tract and along the southeast line of said 28.267 acre tract, to a 5/8 inch iron rod with cap (stamped "Weisser Eng., Houston, TX") set for the southeast corner and POINT OF BEGINNING of the herein described parcel;

- 1) THENCE, South 83°02'57" West, a distance of 1,884.48 feet, along the proposed south right-of-way of F.M. 1093 (width varies) to a 5/8 inch iron rod with cap (stamped "Weisser Eng., Houston, TX") set for a point of the herein described parcel and the beginning of a curve to the right;
- 2) THENCE, in a southwest direction, along the proposed south right-of-way of F.M. 1093 (width varies), with said curve to the right having a radius of 5,044.00 feet, a central angle of 01°43'56" and chord which bears South 83°54'56" West, 152.49 feet, for an arc length of 152.49 feet to a 5/8-inch iron rod with cap stamped "Weisser Eng. Houston, Tx." set in the southwest line of said 28.267 acre tract, in the northeast line of the residue of said 73.742 acre tract and for the southwest corner of the herein described parcel;

EXHIBIT B-2

- 3) THENCE, North 47°37'38" West, a distance of 128.82 feet, along the northeast line of the residue of said 73.742 acre tract, along the southwest line of said 28.267 acre tract and along the southwest line of the herein described parcel, to the existing south right-of-way line of Metropolitan Transit Authority of Harris County, Texas (50 feet wide) as described in Volume 2478, Page 1664 of the Fort Bend County Deed Records (F.B.C.D.R.), Fort Bend County, Texas and filed in the O.P.R.F.B.C. under Clerk's File No. 9277986, to a 5/8-inch iron rod with cap (stamped "Benchmark Eng") found for the northwest corner of the herein described parcel;
- 4) THENCE, North 83°02'57" East, a distance of 2,238.25 feet, along the south right-of-way line of said Metropolitan Transit Authority of Harris County, Texas and the north line of said 28.267 acre tract, to a 5/8-inch iron rod with cap (stamped "Benchmark Eng") found for the northeast corner of the herein described parcel;
- 5) THENCE, South 42°36'44" West, a distance of 154.18 feet, along the northwest line of said 179.7922 acre tract, along the southeast line of said 28.267 acre tract to the POINT OF BEGINNING and containing 4.902 acre (213,546 square feet) parcel of land.

NOTE: The Point of Beginning of this description has coordinates of N=13,817,566.76 and E=2,989,668.05; All bearings are based on the Texas State Plane coordinate system, NAD 83 (1993 Adj.), South Central Zone. All coordinates shown are surface and may be converted to grid by Dividing by TxDOT conversion factor of 1.00013.

NOTE: A parcel plat of even date was prepared in conjunction with this property description.

Compiled by:
Weisser Engineering Company
19500 Park Row, Suite 100
Houston, Texas 77084
December, 2014

CONVENTIONAL SIGNS:

- EXISTING RIGHT-OF-WAY LINE
- ACCESS DENIAL LINE
- PROPOSED RIGHT-OF-WAY LINE
- PROPERTY LINE
- SURVEY LINE

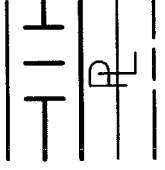

(401)

(3)

DENOTES OWNERSHIP No.

DENOTES BEARING AND DISTANCE NOTE No.

- SET 5/8" I.R. W/TxDOT ALUM. CAP (SEE NOTE 2)
- SET 5/8" I.R. W/TxDOT ALUM. CAP (SEE NOTE 3)
- FOUND 5/8" I.R. W/TxDOT ALUM. CAP
- SET (AS INDICATED)
- FOUND (AS INDICATED)

LEGEND:

- CLERK'S FILE NUMBER
- FILM CODE NUMBER
- OFFICIAL RECORDS OF FORT BEND COUNTY
- FORT BEND COUNTY PLAT RECORDS
- FORT BEND COUNTY DEED RECORDS
- FORT BEND COUNTY COURT RECORDS
- FORT BEND COUNTY DISTRICT COURT RECORDS

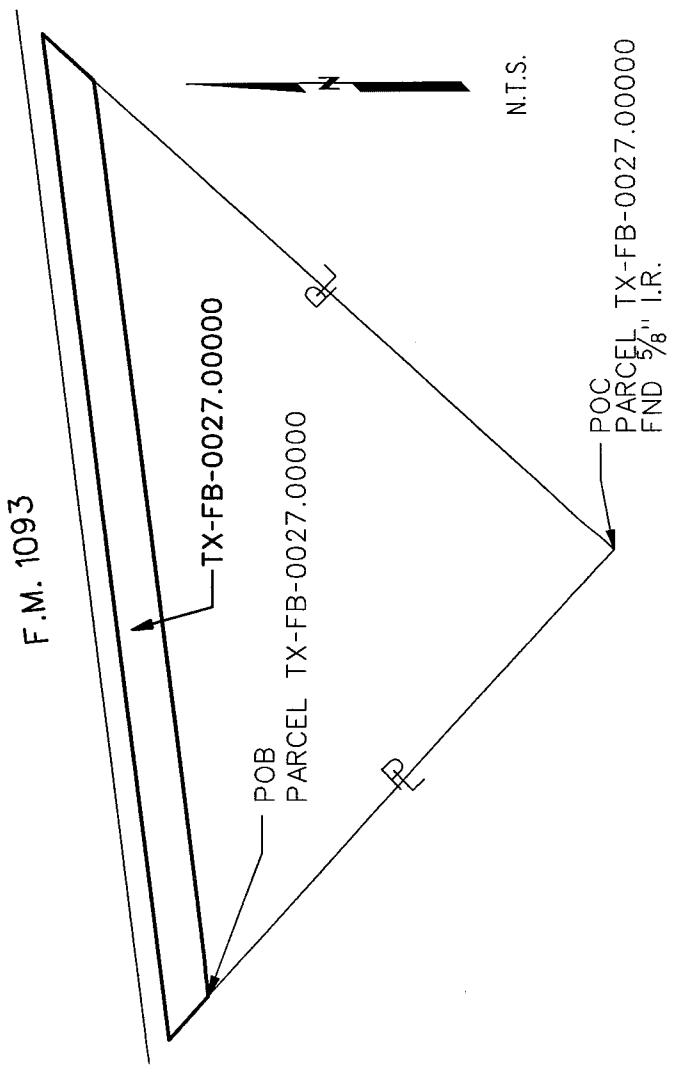

NOTES:

1. A PROPERTY DESCRIPTION OF EVEN DATE WAS PREPARED IN CONJUNCTION WITH THIS PARCEL PLAT.
2. ** THE MONUMENT DESCRIBED AND SET MAY BE REPLACED WITH A TxDOT TYPE II RIGHT-OF-WAY MARKER UPON COMPLETION OF THE HIGHWAY CONSTRUCTION PROJECT UNDER THE SUPERVISION OF A REGISTERED PROFESSIONAL LAND SURVEYOR, EITHER EMPLOYED OR RETAINED BY TxDOT.
3. ALL BEARINGS AND COORDINATES ARE BASED ON THE TEXAS COORDINATE SYSTEM, SOUTH CENTRAL ZONE, NAD 83 (1993 ADJ.). ALL DISTANCES AND COORDINATES SHOWN ARE SURFACE AND MAY BE CONVERTED TO GRID BY DIVIDING BY A COMBINED ADJUSTMENT FACTOR OF 1.000013.
4. ABSTRACTING PERFORMED BY: W.E.C. 07/2014.
5. GROUND SURVEY PERFORMED 03/2012 AND 09/2014.

EXISTING	TAKING AC/SF	REMAINING
28.267 AC	4.902 AC	23.365 L.T.
 WEISSER Engineering Co. 19500 Park Row, Suite 100 Houston, Texas 77084 (281) 579 - 7300		
PARCEL PLAT SHOWING PARCEL TX-FB-0027.00000 F.M. 1093 FORT BEND COUNTY, TEXAS		
DATE: 09/2014 SCALE: N.T.S. JOB No.: EG676 RCSJ No.: 1258-03-043 DWG. No.: TX-FB-0027.00000-01		

F.M. 1093

(100' R.O.W.)
VOL. 285, PG. 260
VOL. 285, PG. 284
VOL. 285, PG. 287
VOL. 285, PG. 292
(1-800-METRO-TRANSIT)
F.B.C.D.R.

475+100 METROPOLITAN TRANSIT
SOUTH CROSS ENERGY AUTHORITY OF HARRIS
COUNTY TEXAS

C.F. NO. 9277986
VOL. 2478 PG. 1664
O.P.R.F.B.C.

MCI/MH
FND. 5/8" I.R. W/CAP
STAMPED "BENCHMARK ENG"

Incross Energy
Pipe Line
(877-880-9022)
SURVEY LINE
Cable Sign
(1-800-880-9022)
MCI-Work
Point Energy Gas Sign
(1-800-880-9022)

RESIDUE OF A
CALLED 73.742 ACRES
L.O.B. LIMITED PARTNERSHIP
C.F. NO. 2007114627
DATE: SEPTEMBER 7, 2007
O.P.R.F.B.C.

L.A. PATILLO
SURVEY, A-507
WALTON, HILL &
SURVEY A-435

TX-FB-0027.00000

S/O 477+24.08,
160.50' RT

S/O 475+71.76, 158.20' RT

PROPOSED R.O.W.

R= 5,044.00'
D= 01° 43' 56"
L= 152.49'
CH= S 83° 54' 56" W-152.49'
RAD. BRG.- N 06° 57' 03" W

PROPOSED R.O.W.
S 83° 02' 57" W
1,884.48'

CALLLED 28.267 ACRES
L.O.B. LIMITED PARTNERSHIP
C.F. NO. 2007068297
DATE: JUNE 4, 2007
O.P.R.F.B.C.

BASELINE

EXISTING R.O.W.

EXISTING R.O.W.
N 83° 02' 57" E-2,238.25'

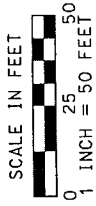

MATCH LINE SEE SHEET 5



19500 Park Row, Suite 100
Houston, Texas 77084
(281) 579 - 7300

PARCEL PLAT SHOWING PARCEL TX-FB-0027.00000
F.M. 1093
FORT BEND COUNTY, TEXAS

DATE: 09/2014 SCALE: 1"= 50' JOB No.: FG676
RCSJ No.: 1258-03-043 DWG. No.: TX-FB-0027_00000-02

F.M. 1093
 (100' R.O.W.)
 VOL. 285, PG. 260
 VOL. 285, PG. 284
 VOL. 285, PG. 287
 VOL. 285, PG. 292
 F.B.C.D.R.

480+00 METROPOLITAN TRANSIT
 AUTHORITY OF HARRIS
 COUNTY, TEXAS
 C.F. NO. 9277986
 VOL. 2478, PG. 1664
 O.P.R.F.B.C.

N 83° 02' 57" E-2,238.25'

TX-FB-0027.00000

PROPOSED R.O.W.

S 83° 02' 57" W-1,884.48'

L.A. PATILLO
 SURVEY, A-307

CALLED 28.267 ACRES
 L.O.B. LIMITED PARTNERSHIP
 C.F. NO. 2007068297
 DATE: JUNE 4, 2007
 O.P.R.F.B.C.

BASELINE

EXISTING R.O.W.

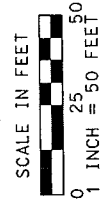

MATCH LINE SEE SHEET 6

MATCH LINE SEE SHEET 4



19500 Park Row, Suite 100
 Houston, Texas 77084
 (281) 579 - 7300

PARCEL PLAT SHOWING PARCEL TX-FB-0027.00000
 F.M. 1093
 FORT BEND COUNTY, TEXAS

DATE: 09/2014 | SCALE: 1" = 50' | JOB No.: FG676
 RCSJ No.: 1258-03-043 | DWG. No.: TX-FB-0027_00000-03

SHEET 5 OF 9

F.M. 1093

(100' R.O.W.)
VOL. 285, PG. 260
VOL. 285, PG. 284
VOL. 285, PG. 287
VOL. 285, PG. 292
F.B.C.D.R.

METROPOLITAN TRANSIT 485+00
AUTHORITY OF HARRIS
COUNTY, TEXAS

C.F. NO. 0277986
VOL. 2478, PG. 1664
O.P.R.F.B.C.

N 83° 02'57" E-2,238.25'

EXISTING R.O.W.

TX-FB-0027.00000

PROPOSED R.O.W.

S 83° 02'57" W-1,884.48'

L.A. PATILLO
SURVEY, A-307

CALLED 28.267 ACRES
L.O.B. LIMITED PARTNERSHIP
C.F. NO. 2007068297
DATE: JUNE 4, 2007
O.P.R.F.B.C.

MATCH LINE SEE SHEET 5

MATCH LINE SEE SHEET 7

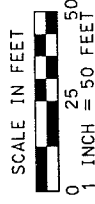

 WBISSER Engineering Co.	19500 Park Row, Suite 100 Houston, Texas 77084 (281) 579 - 7300
	PARCEL PLAT SHOWING, PARCEL TX-FB-0027.00000 F.M. 1093 FORT BEND COUNTY, TEXAS
DATE: 09/2014 SCALE: 1" = 50'	JOB No.: FG676
RCSJ No.: 1258-03-043	DWG. No.: TX-FB-0027_00000-04

F.M. 1093

(100' R.O.W.)
VOL. 285, PG. 260
VOL. 285, PG. 284
VOL. 285, PG. 287
VOL. 285, PG. 292
F.B.C.D.R.

METROPOLITAN TRANSIT
AUTHORITY OF HARRIS
COUNTY, TEXAS

C.F. NO. 9277986
VOL. 2478, PG. 1664
O.P.R.F.B.C.

N 83° 02' 57" E-2,238.25'

BASELINE

EXISTING R.O.W.

490+00

EXISTING R.O.W.

TX-FB-0027.00000

PROPOSED R.O.W.

S 83° 02' 57" W-1,884.48'

CALLED 28.267 ACRES
L.O.B. LIMITED PARTNERSHIP
C.F. NO. 2007068297
DATE: JUNE 4, 2007
O.P.R.F.B.C.

L.A. PATILLO
SURVEY, A-307

MATCH LINE SEE SHEET 6

MATCH LINE SEE SHEET 8

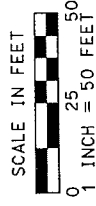

 WEISSER Engineering Co.	19500 Park Row Suite 100 Houston, Texas 77084 (281) 579 - 7300
	PARCEL PLAT SHOWING PARCEL TX-FB-0027.00000 F.M. 1093 FORT BEND COUNTY, TEXAS
DATE: 09/2014 SCALE: 1" = 501 JOB No.: EG676 RCSJ No.: 1258-03-043 DWG. No.: TX-FB-0027_00000-05	

F.M. 1093

(100' R.O.W.)
VOL. 285, PG. 260
VOL. 285, PG. 284
VOL. 285, PG. 287
VOL. 285, PG. 292
F.B.C.D.R.

METROPOLITAN TRANSIT
AUTHORITY OF HARRIS
COUNTY TEXAS
C.F. NO. 9277986
VOL. 2478 PG. 1664
O.P.R.F.B.C.

N 83° 02' 57" E-2,238.25'

EXISTING R.O.W.

494+00

BASELINE

EXISTING R.O.W.

TX-FB-0027.00000

PROPOSED R.O.W.

S 83° 02' 57" W-1,884.48'

L.A. PATILLO
SURVEY, A-307

CALLED 28.267 ACRES
L.O.B. LIMITED PARTNERSHIP
C.F. NO. 2007068297
DATE: JUNE 4, 2007
O.P.R.F.B.C.

MATCH LINE SEE SHEET 7

MATCH LINE SEE SHEET 9

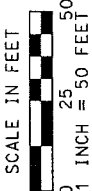
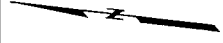

 WEISSER Engineering Co.	19500 Park Row, Suite 100 Houston, Texas 77084 (281) 579 - 7300
	PARCEL PLAT SHOWING PARCEL TX-FB-0027.00000 F.M. 1093 FORT BEND COUNTY, TEXAS
DATE: 09/2014 SCALE: 1" = 50' JOB No.: FG676 RCSJ No.: 1258-03-043 DWG. No.: TX-FB-0027_00000-05	

F.M. 1093

(R.O.W. VARIES)
VOL. 175, PG. 146
VOL. 285, PG. 257
F.B.C.D.R.

497+00

METROPOLITAN TRANSIT
AUTHORITY OF HARRIS
COUNTY, TEXAS
C.F. NO. 9277986
VOL. 2478, PG. 1664
O.P.R.F.B.C.

N 83° 02'57" E-2,238.25' O.P.R.F.B.C.

CALLLED 28.267 ACRES
L.O.B. LIMITED PARTNERSHIP
C.F. NO. 2007068297
DATE: JUNE 4, 2007
O.P.R.F.B.C.

TX-FB-0027.00000

PROPOSED R.O.W.

S 83° 02'57" W
1,884.48' E

T 54° 33' 44" S
3,614.33'

S 42° 36' 44" W-154.18'

P.O.B.
PARCEL TX-FB-0027.00000
N-13,817,566.76
E- 2,989,668.05
S/O 496+04.55, 164.83 RT

P.O.C.
PARCEL TX-FB-0027.00000
END. 5/8" I.R. W/CAP
STAMPED "BENCHMARK ENG"

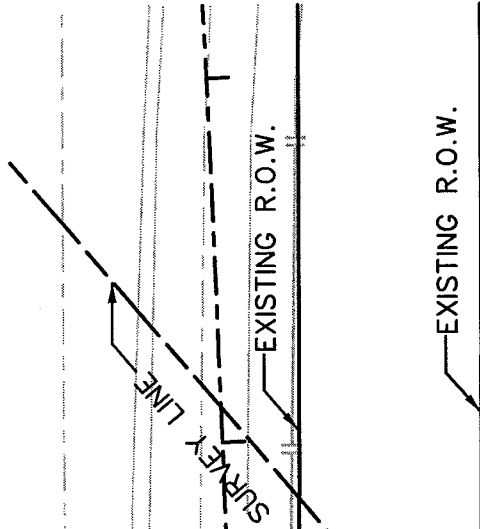

END 5/8" I.R. W/CAP
STAMPED "BENCHMARK ENG"

EXISTING R.O.W.

CALLLED 179.7922 ACRES
L.O.B. LIMITED PARTNERSHIP
C.F. NO. 2005083650
DATE: MARCH 8, 2005
O.P.R.F.B.C.

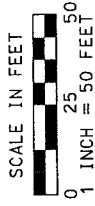

MATCH LINE SEE SHEET 8



19500 Park Row, Suite 100
Houston, Texas 77084
(281) 579 - 7300

PARCEL PLAT SHOWING PARCEL TX-FB-0027.00000
F.M. 1093
FORT BEND COUNTY, TEXAS

DATE: 09/2014 SCALE: 1" = 50'
RCSJ No.: 1258-03-043 JOB No.: EGG76
DWG. No.: TX-FB-0027-00000-07

EXHIBIT B-3

County: Fort Bend
Highway: F.M. 1093
Project Limits: F.M. 359 to Hwy. 99 (Grand Parkway)

Property Description for Parcel TX-FB-0029.00000 (Part 1 and 2)

Being a 2.439 acre (106,260 square feet) parcel of land, out of the Walton, Hill & Walton "A" Survey A-435, Fort Bend County, Texas, and being part of and out of the residue of a called 73.742 acre tract of land, described in a Deed from Lutheran Education Association of Houston to L.O.B. Limited Partnership, filed in the Official Public Records of Fort Bend County (O.P.R.F.B.C.) Fort Bend County, Texas, under Clerk's File No. 2007114627, being more particularly described as follows:

Part 1

COMMENCING at a 5/8-inch iron rod with cap (stamped "Benchmark Eng") found for the east corner of the residue of said 73.742 acre tract, for the west corner of a called 179.7922 acre tract of land, described in Deed from Pacific Richland Investments and Richfield Investment Corporation to L.O.B. Limited Partnership, filed in the O.P.R.F.B.C. under Clerk's File No. 2005083650 and for the south corner of 28.267 acre tract of land, described in a Deed from LUED Corporation to L.O.B. Limited Partnership, filed in the O.P.R.F.B.C. under Clerk's File No. 2007068297, thence as follows:

North 47°37'38" West, a distance of 1,322.95 feet, along the northeast line of the residue of said 73.742 acre tract and along the southwest line of said 28.267 acre tract, to a 5/8 inch iron rod with cap (stamped "Weisser Eng., Houston, TX") set in the proposed south right-of-way of F.M. 1093 (width varies) for the southeast corner and POINT OF BEGINNING of the herein described parcel and the beginning of a curve to the right;

- 1) THENCE, in a westerly direction, along the proposed south right-of-way of F.M. 1093 (width varies) with said curve to the right having a radius of 5,044.00 feet, a central angle of 00°56'44" and chord which bears South 85°15'15" West, 83.25 feet, for an arc length of 83.25 feet to a 5/8-inch iron rod with cap stamped "Weisser Eng. Houston, Tx." set for a point of the herein described parcel;
- 2) THENCE, South 85°43'37" West, a distance of 84.74 feet, along the proposed south right-of-way of F.M. 1093 (width varies) to a 5/8 inch iron rod with cap (stamped "Weisser Eng., Houston, TX") set for a point of the herein described parcel and the beginning of a curve to the left;

EXHIBIT B-3

- 3) THENCE, in a southwest direction, along the proposed south right-of-way of F.M. 1093 (width varies) with said curve to the left having a radius of 4,956.00 feet, a central angle of $02^{\circ}41'59''$ and chord which bears South $84^{\circ}22'38''$ West, 233.51 feet, for an arc length of 233.53 feet to a 5/8-inch iron rod with cap stamped "Weisser Eng. Houston, Tx." set for a point of the herein described parcel;
- 4) THENCE, South $83^{\circ}01'38''$ West, a distance of 180.61 feet, along the proposed south right-of-way of F.M. 1093 (width varies) to a 5/8 inch iron rod with cap (stamped "Weisser Eng., Houston, TX") set for a point of the herein described parcel;
- 5) THENCE, South $33^{\circ}00'56''$ West, a distance of 38.56 feet, along the proposed south right-of-way of F.M. 1093 (width varies), to the existing northeast right-of-way line of Katy Gaston Road (80 feet wide), to a 5/8 inch iron rod with cap (stamped "Weisser Eng., Houston, TX") set for the southwest corner of the herein described parcel;
- 6) THENCE, North $16^{\circ}58'48''$ West, a distance of 116.31 feet, along the existing northeast right-of-way line of said Katy Gaston Road (80 feet wide), to a 5/8-inch iron rod with cap (stamped "Benchmark Eng") found in the south right-of-way line of Metropolitan Transit Authority of Harris County, Texas (50 feet wide) as described in Volume 2478, Page 1664 of the Fort Bend County Deed Records (F.B.C.D.R.), Fort Bend County, Texas and filed in the O.P.R.F.B.C. under Clerk's File No. 9277986 and for the northwest corner of the herein described parcel;
- 4) THENCE, North $83^{\circ}01'38''$ East, a distance of 542.95 feet, along the south right-of-way line of said Metropolitan Transit Authority of Harris County, Texas (50 feet wide) and the north line of said 73.742 acre tract, to a 5/8-inch iron rod with cap (stamped "Benchmark Eng") found for the northeast corner of the herein described parcel;
- 5) THENCE, South $47^{\circ}37'38''$ East, a distance of 128.82 feet, along the northeast line of the residue of said 73.742 acre tract, along the southwest line of said 28.267 acre tract to the POINT OF BEGINNING and containing 1.170 acre (50.985 square feet) parcel of land for Part 1.

NOTE: The Point of Beginning of this description has coordinates of N=13,817,322.55 and E=2,987,645.79;

EXHIBIT B-3

Part 2

COMMENCING at a 5/8-inch iron rod found for a southwest corner of a called 73.7497 acre tract of land, described in Deed from Comerica Bank-Texas to Reid Management Company, filed in the Official Public Records of Fort Bend County (O.P.R.F.B.C.) Fort Bend County, Texas, under Clerk's File No. 9524221, and for the southeast corner of the residue of said 73.742 acre tract, thence as follows:

North 34°37'59" West, a distance of 2,281.91 feet, along the northeast line of said 73.7497 acre tract and along the southwest line of the residue of said 73.742 acre tract, to a 5/8 inch iron rod with cap (stamped "Weisser Eng., Houston, TX") set for the southwest corner and POINT OF BEGINNING of the herein described parcel;

- 1) THENCE, North 34°38'06" West, a distance of 90.26 feet, along the southwest line of the residue of said 73.742 acre tract, along the northeast line of said 73.7497 acre tract and along the southwest line of the herein described parcel, to the existing south right-of-way line of Metropolitan Transit Authority of Harris County, Texas (50 feet wide) as described in Volume 2478, Page 1664 of the Fort Bend County Deed Records (F.B.C.D.R.), Fort Bend County, Texas and filed in the O.P.R.F.B.C. under Clerk's File No. 9277986, to a 5/8 inch iron rod (stamped "Benchmark Eng") found for the northwest corner of the herein described parcel;
- 2) THENCE, North 83°01'38" East, a distance of 665.08 feet, along the south right-of-way line of said Metropolitan Transit Authority of Harris County, Texas and the north line of the residue of said 73.742 acre tract,), to the existing southwest right-of-way line of Katy Gaston Road (80 feet wide), to a 5/8 inch iron rod with cap (stamped "Benchmark Eng") set for the northeast corner of the herein described parcel;
- 3) THENCE, South 16°58'48" East, a distance of 116.31 feet, along the existing southwest right-of-way line of Katy Gaston Road (80 feet wide), to a 5/8 inch iron rod with cap (stamped "Weisser Eng., Houston, TX") set for the southeast corner of the herein described parcel;
- 4) THENCE, North 56°59'04" West, a distance of 45.97 feet, along the proposed south right-of-way of F.M. 1093 (width varies) to a 5/8 inch iron rod with cap (stamped "Weisser Eng., Houston, TX") set for a point in the herein described parcel;

EXHIBIT B-3

- 5) THENCE, South 83°01'38" West, a distance of 278.26 feet, along the proposed south right-of-way of F.M. 1093 (width varies) to a 5/8 inch iron rod with cap (stamped "Weisser Eng., Houston, TX") set for a point in the herein described parcel;
- 6) THENCE, South 83°03'15" West, a distance of 93.47 feet, along the proposed south right-of-way of F.M. 1093 (width varies) to a 5/8 inch iron rod with cap (stamped "Weisser Eng., Houston, TX") set for a point in the herein described parcel and the beginning of a curve to the left;
- 7) THENCE, in a southwest direction, with said curve to the left having a radius of 6,524.00 feet, a central angle of 01°42'12" and chord which bears South 84°05'20" West, 193.93 feet, for an arc length of 193.94 feet to a 5/8-inch iron rod with cap stamped "Weisser Eng. Houston, Tx." set in the proposed south right-of-way line of said F.M. 1093 for a point of the herein described parcel;
- 8) THENCE, South 84°56'26" West, a distance of 42.57 feet, along the proposed south right-of-way of F.M. 1093 (width varies), to the POINT OF BEGINNING and containing 1.269 acre (55,275 square feet) parcel of land for Part 2.

NOTE: The Point of Beginning of this description has coordinates of N=13,817,173.65 and E=2,986,281.87; All bearings are based on the Texas State Plane coordinate system, NAD 83 (1993 Adj.), South Central Zone. All coordinates shown are surface and may be converted to grid by Dividing by TxDOT conversion factor of 1.00013.

NOTE: A parcel plat of even date was prepared in conjunction with this property description.

Compiled by:
Weisser Engineering Company
19500 Park Row, Suite 100
Houston, Texas 77084
December, 2014

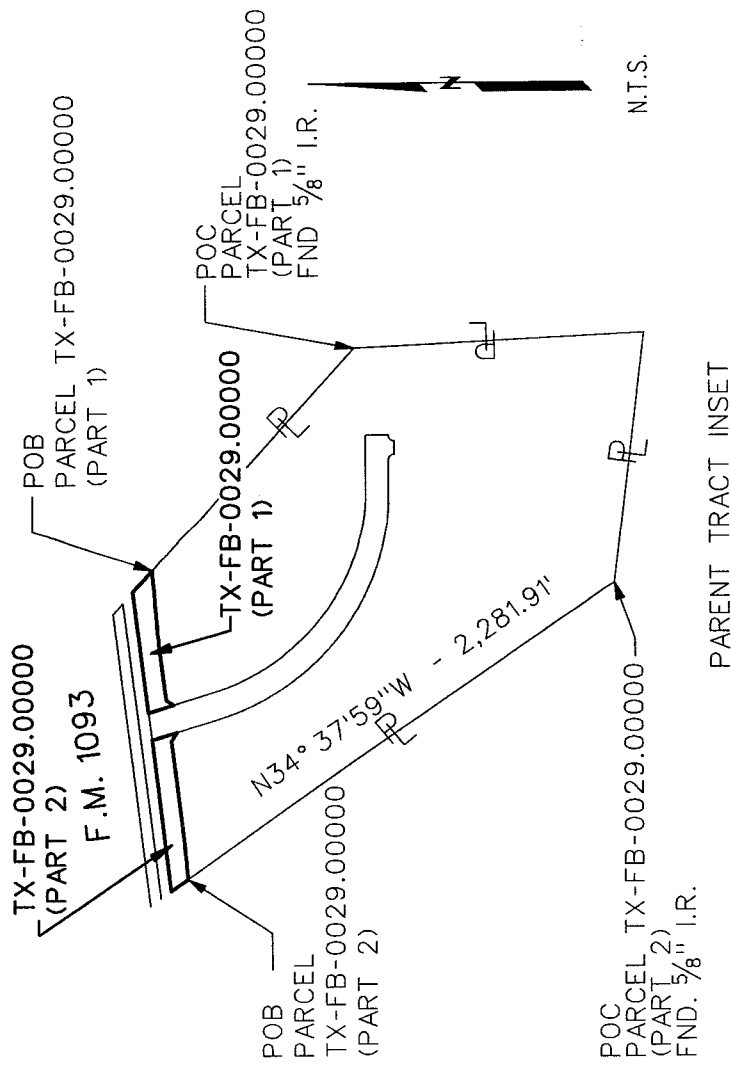

CONVENTIONAL SIGNS:

- EXISTING RIGHT-OF-WAY LINE
- ACCESS DENIAL LINE
- PROPOSED RIGHT-OF-WAY LINE
- PROPERTY LINE
- SURVEY LINE



- DENOTES OWNERSHIP No.
- DENOTES BEARING AND DISTANCE NOTE No.
- SET 5/8" I.R. W/TxDOT ALUM. CAP (SEE NOTE 2)
- SET 5/8" I.R. W/TxDOT ALUM. CAP (SEE NOTE 3)
- FOUND 5/8" I.R. W/TxDOT ALUM. CAP
- SET (AS INDICATED)
- FOUND (AS INDICATED)

LEGEND:

- CLERK'S FILE NUMBER
- FILM CODE NUMBER
- OFFICIAL RECORDS OF FORT BEND COUNTY
- FORT BEND COUNTY PLAT RECORDS
- FORT BEND COUNTY DEED RECORDS
- FORT BEND COUNTY COURT RECORDS
- FORT BEND COUNTY DISTRICT COURT RECORDS

NOTES:

1. A PROPERTY DESCRIPTION OF EVEN DATE WAS PREPARED IN CONJUNCTION WITH THIS PARCEL PLAT.
2. ** THE MONUMENT DESCRIBED AND SET MAY BE REPLACED WITH A TxDOT TYPE II RIGHT-OF-WAY MARKER UPON COMPLETION OF THE HIGHWAY CONSTRUCTION PROJECT UNDER THE SUPERVISION OF A REGISTERED PROFESSIONAL LAND SURVEYOR, EITHER EMPLOYED OR RETAINED BY TxDOT.
3. ALL BEARINGS AND COORDINATES ARE BASED ON THE TEXAS COORDINATE SYSTEM, SOUTH CENTRAL ZONE, NAD 83 (1993 ADJ.). ALL DISTANCES AND COORDINATES SHOWN ARE SURFACE AND MAY BE CONVERTED TO GRID BY DIVIDING BY A COMBINED ADJUSTMENT FACTOR OF 1.00013.
4. ABSTRACTING PERFORMED BY: W.E.C. 07/2014.
5. GROUND SURVEY PERFORMED 03/2012 AND 09/2014.

EXISTING	TAKING AC/SF	REMAINING
69,028 AC	PART 1 1,170 AC 50,985 SF	66,589 LT.
	PART 2 1,269 AC 55,275 SF	



19500 Park Row, Suite 100
Houston, Texas 77084
(281) 579 - 7300

PARCEL PLAT SHOWING
PARCEL TX-FB-0029.00000 (PART 1 & 2) F.M. 1093
FORT BEND COUNTY, TEXAS

DATE: 09/2014 SCALE: N.T.S. JOB No.: EG676
RCSJ No.: 1258-03-043 DWG. No.: TX-FB-0029.00000-01

F.M. 1093
(100' R.O.W.)

VOL. 285, PG. 260
VOL. 285, PG. 284
VOL. 285, PG. 287
VOL. 285, PG. 292
F.B.C.D.R.

METROPOLITAN TRANSIT
AUTHORITY OF HARRIS
COUNTY, TEXAS

C.F. NO. 9277986
VOL. 2478, PG. 1664
O.P.R.F.B.C.

N 83° 01'38" E-542.95'

BASELINE

EXISTING R.O.W.

SCALE IN FEET
0 25 50
1 INCH = 50 FEET

MATCH LINE SEE SHEET 5

EXISTING R.O.W.

FND. 5/8" I.R. W/GAP
STAMPED "BENCHMARK ENG"

TX-FB-0029.00000 (PART 1)

S/O 469+89.72, 145.69' RT

PROPOSED R.O.W.

S 83° 01'38" W-180.61'

S 33° 00'56" W-38.56'

R= 4,956.00'
D= 02° 41'59"
L= 233.53'
CH= S 84° 22'38" W-233.51'
RAD. BRG.= S 04° 16'23" E

S/O 471+70.33, 145.62' RT

N 46° 58'48" W
116.31'

KATY GASTON RD
(80' R.O.W.)

RESIDUE OF A
CALLED 73.742 ACRES
L.O.B. LIMITED PARTNERSHIP
C.F. NO. 2007114627
DATE: SEPTEMBER 7, 2007
O.P.R.F.B.C.



19500 Park Row, Suite 100
Houston, Texas 77084
(281) 579 - 7300

PARCEL PLAT SHOWING
PARCEL TX-FB-0029.00000 (PART 1) F.M. 1093
FORT BEND COUNTY, TEXAS

DATE: 09/20/14 SCALE: 1"= 50' JOB No.: EG676

RCSJ No.: 1258-03-043 DWG. No.: TX-FB-0029-00000-02

SHEET 6 OF 9

F.M. 1093

(100' R.O.W.)
VOL. 285, PG. 260
VOL. 285, PG. 284
VOL. 285, PG. 287
VOL. 285, PG. 292
F.B.C.D.R.

SCALE IN FEET
0 25 50
1 INCH = 50 FEET

METROPOLITAN TRANSIT
AUTHORITY OF HARRIS
COUNTY TEXAS
C.F. NO. 9277986
VOL. 2478, PG. 1664
O.P.R.F.B.C.

N 83° 01'38" E-542.95'

EXISTING R.O.W.

TX-FB-0029.00000 (PART 1)

S/O 474+88.42, 154.99' RT

S/O 474+03.77, 151.03' RT

PROPOSED R.O.W.

S 85° 43'37" W-84.74'

R= 4,956.00'
D= 02° 41'59"
L= 233.53'
CH= S 84° 22'38" W-233.51'
RAD. BRG.= S 04° 16'23" E

R= 5,044.00'
D= 00° 56'44"
L= 83.25'
CH= S 85° 15'15" W-83.25'
RAD. BRG.= N 05° 13'07" W

RESIDUE OF A
CALLED 73.742 ACRES
L.O.B. LIMITED PARTNERSHIP
C.F. NO. 2007114627
DATE: SEPTEMBER 7, 2007
O.P.R.F.B.C.

P.O.B.
PARCEL TX-FB-0029.00000 (PART 1)
N=13,817,322.55
E= 2,987,645.79

475+00

END 5/8" I.R. W/CAP
STAMPED "BENCHMARK ENG"

WALTON HILL &
WALTON "A"
SURVEY A-402

S 47° 37'38" E-128.82'

SURVEY LINE

L.A. PATILLO
SURVEY, A-307

CALLED 28.267 ACRES
L.O.B. LIMITED PARTNERSHIP
C.F. NO. 2007068297
DATE: JUNE 4, 2007
O.P.R.F.B.C.

N 47° 37'38" W-1,322.95'

P.O.C.
PARCEL TX-FB-0029.00000
(PART 1)
END 5/8" I.R. W/CAP
STAMPED "BENCHMARK ENG"

WEISSER
Engineering Co.
19500 Park Row, Suite 100
Houston, Texas 77084
(281) 579 - 7300

PARCEL PLAT SHOWING
PARCEL TX-FB-0029.00000 (PART 1) F.M. 1093
FORT BEND COUNTY, TEXAS

DATE: 09/2014 SCALE: 1"= 50'
JOB No.: F.G.676
RCSJ No.: 1258-03-043
DWG. No.: TX-FB-0029.00000-03

SHEET 7 OF 9

MATCH LINE SEE SHEET 4

WALTON, HILL & WALTON "A"
SURVEY A-435 F.M. 1093

(100' R.O.W.)
EXISTING R.O.W.
VOL. 285, PG. 260
VOL. 285, PG. 284
VOL. 285, PG. 287
VOL. 285, PG. 292
F.B.C.D.R.

METROPOLITAN TRANSIT
AUTHORITY OF HARRIS
COUNTY, TEXAS
C.F. NO. 9277986
VOL. 2478, PG. 1664
FND. 5/8" I.R. W/CAP
STAMPED "BENCHMARK ENG"

N 83° 01'38" E-665.08'

465+00

BASELINE

EXISTING R.O.W.

TX-FB-0029.00000 (Part 2)

S/O 462+42.24, 142.34' RT

S/O 464+36.14, 145.86' RT

PROPOSED R.O.W.
S 83° 03'15" W
93.47'

R = 6,524.00'
D = 01° 42' 12"
L = 193.94'
CH = S 84° 05' 20" W - 193.93'
RAD. BRG. = N 06° 45' 46" W

S 84° 56' 26" W - 42.57'

N 34° 37' 59" W - 2,281.9'

P.O.B.
PARCEL TX-FB-0029.00000
(PART 2)
N-13, 817, 173.65
E-2, 986, 281.87
S/O 461+99.69, 140.93' RT

CALLED 73.7497 ACRES
REID MANAGEMENT COMPANY
C.F. NO. 9524221
DATE: APRIL 24, 1995
O.P.R.F.B.C.

RESIDUE OF A
CALLED 73.742 ACRES
L.O.B. LIMITED PARTNERSHIP
C.F. NO. 2007114627
DATE: SEPTEMBER 7, 2007
O.P.R.F.B.C.
P.O.C.
PARCEL TX-FB-0029.00000 (PART 2)
FND. 5/8" I.R.

WEISSER Engineering Co.
19500 Park Row, Suite 100
Houston, Texas, 77084
(281) 579 - 7300

PARCEL PLAT SHOWING PARCEL
TX-FB-0029.00000 (PART 2)- F.M. 1093
FORT BEND COUNTY, TEXAS

DATE: 09/2014 SCALE: 1" = 50'
JOB No.: FG676
RCSJ No.: 1258-03-043
DWG. No.: TX-FB-0029.00000-04

SHEET 8 OF 9

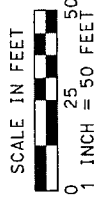

MATCH LINE SEE SHEET 5

F.M. 1093

(100' R.O.W.)
VOL. 285, PG. 260
VOL. 285, PG. 284
VOL. 285, PG. 287
VOL. 285, PG. 292
F.B.C.D.R.

METROPOLITAN TRANSIT
AUTHORITY OF HARRIS
COUNTY, TEXAS
C.F. NO. 9277986
VOL. 2478, PG. 1664
O.P.R.F.B.C.

N 83° 01'38" E-665.08'

EXISTING R.O.W.

TX-FB-0029.00000 (PART 2)

S/O 465+29.60, 145.87' RT

N.E.
116.1

S 83° 01'38" W-278.26'

PROPOSED R.O.W.
S/O 468+07.86, 145.76' RT

N 56° 59'04" W-45.97'

RESIDUE OF A
CALLED 73.742 ACRES
L.O.B. LIMITED PARTNERSHIP
C.F. NO. 2007114627
DATE: SEPTEMBER 7, 2007
O.P.R.F.B.C.

WALTON, HILL & WALTON "A"
SURVEY A-455

EXISTING R.O.W.

BASELINE

468+00

FND. 5/8" I.R.W./CAP
STAMPED "BENCHMARK ENG"

KATY GASTON RD
(80' R.O.W.)

S/O 468+43.10, 175.29' RT

S 16° 58'48" E
116.31'

SET

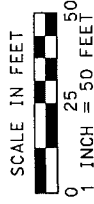
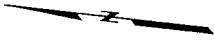

MATCH LINE SEE SHEET 4

WEISSER Engineering Co.
19500 Park Row, Suite 100
Houston, Texas 77084
(281) 579 - 7300

PARCEL PLAT SHOWING PARCEL
TX-FB-0029.00000 (PART 2) - F.M. 1093
FORT BEND COUNTY, TEXAS

DATE: 09/2014 SCALE: 1"= 50' JOB No.: FG676

RCSJ No.: 1258-03-043 DWG. No.: TX-FB-0029.00000-05

SHEET 9 OF 9

EXHIBIT B-4

County: Fort Bend
Highway: F.M. 1093
Project Limits: F.M. 359 to Hwy. 99 (Grand Parkway)

Property Description for Parcel TX-FB-0030.00000

Being a 1.885 acre (82,113 square feet) parcel of land, out of the Walton, Hill & Walton "A" Survey A-435, Fort Bend County, Texas, and being part of and out of a called 73.7497 acre tract of land, described in Deed from Comerica Bank-Texas to Reid Management Company, filed in the Official Public Records of Fort Bend County (O.P.R.F.B.C.) Fort Bend County, Texas, under Clerk's File No. 9524221, said 1.885 acre tract being more particularly described as follows:

COMMENCING at a 5/8-inch iron rod found for a southwest corner of the residue of a called 73.742 acre tract of land, described in a Deed from Lutheran Education Association of Houston to L.O.B. Limited Partnership, filed in the O.P.R.F.B.C. under Clerk's File No. 2007114627, and for the southeast corner of said 73.7497 acre tract, thence as follows:

North 34°37'59" West, a distance of 2,281.91 feet, along the northeast line of said 73.7497 acre tract and along the southwest line of the residue of said 73.742 acre tract, to a 5/8 inch iron rod with cap (stamped "Weisser Eng., Houston, TX") set for the southeast corner and POINT OF BEGINNING of the herein described parcel;

- 1) THENCE, South 84°56'26" West, a distance of 87.03 feet, along the proposed south right-of-way of F.M. 1093 (width varies) to a 5/8 inch iron rod with cap (stamped "Weisser Eng., Houston, TX") set for a point of the herein described parcel and the beginning of a curve to the left;
- 2) THENCE, in a southwest direction, with said curve to the left having a radius of 6,436.00 feet, a central angle of 01°57'15" and chord which bears South 83°57'49" West, 219.49 feet, for an arc length of 219.50 feet to a 5/8-inch iron rod with cap stamped "Weisser Eng. Houston, Tx." set in the proposed south right-of-way line of said F.M. 1093 for a point of the herein described parcel;
- 3) THENCE, South 82°59'11" West, a distance of 163.76 feet, along the proposed south right-of-way of F.M. 1093 (width varies) to a 5/8 inch iron rod with cap (stamped "Weisser Eng., Houston, TX") set for a point of the herein described parcel and the beginning of a curve to the right;

EXHIBIT B-4

- 4) THENCE, in a southwest direction, with said curve to the right having a radius of 6,524.00 feet, a central angle of $05^{\circ}16'35''$ and chord which bears South $85^{\circ}37'29''$ West, 600.58 feet, for an arc length of 600.79 feet to a 5/8-inch iron rod with cap stamped "Weisser Eng. Houston, Tx." set in the proposed south right-of-way line of said F.M. 1093 for a point of the herein described parcel;
- 5) THENCE, South $88^{\circ}15'46''$ West, a distance of 213.68 feet, along the proposed south right-of-way of F.M. 1093 (width varies) to a 5/8 inch iron rod with cap (stamped "Weisser Eng., Houston, TX") set for a point of the herein described parcel and the beginning of a curve to the left;
- 6) THENCE, in a southwest direction, with said curve to the left having a radius of 6,436.00 feet, a central angle of $00^{\circ}47'00''$ and chord which bears South $87^{\circ}52'16''$ West, 88.00 feet, for an arc length of 88.00 feet to a 5/8-inch iron rod with cap stamped "Weisser Eng. Houston, Tx." set in the southwest line of said 73.7497 acre tract, in the northeast line of a called 56.517 acre tract of land, described in Deed from Robert L. Dabney, Jr. and William Nelson to Tanoureen, Ltd., A Texas Limited Partnership, filed in the Official Public Records of Fort Bend County (O.P.R.F.B.C.) Fort Bend County, Texas, under Clerk's File No. 2005135716, and for the southwest corner of the herein described parcel;
- 7) THENCE, North $06^{\circ}58'12''$ West, a distance of 19.42 feet, along the southwest line of said 73.7497 acre tract, along the northeast line of said 56.517 acre tract and along the southwest line of the herein described parcel, to the existing south right-of-way line of Metropolitan Transit Authority of Harris County, Texas (50 feet wide) as described in Volume 2478, Page 1664 of the Fort Bend County Deed Records (F.B.C.D.R.), Fort Bend County, Texas and filed in the O.P.R.F.B.C. under Clerk's File No. 9277986, to a 5/8 inch iron rod stamped "Benchmark Eng" found for the northwest corner of the herein described parcel;
- 8) THENCE, North $83^{\circ}01'38''$ East, a distance of 1,328.72 feet, along the south right-of-way line of said Metropolitan Transit Authority of Harris County, Texas and the north line of said 73.7497 acre tract, to a 5/8 inch iron rod stamped "Benchmark Eng" found for the northeast corner of the herein described parcel;
- 9) THENCE, South $34^{\circ}38'06''$ East, a distance of 90.26 feet, along the southwest line of the residue of said 73.742 acre tract, along the northeast line of said 73.7497 acre tract and along the northeast line of the herein described parcel, to the POINT OF BEGINNING and containing 1.885 acre (82,113 square feet) parcel of land;

EXHIBIT B-4

NOTE: The Point of Beginning of this description has coordinates of N=13,817,173.65 and E=2,986,281.87; All bearings are based on the Texas State Plane coordinate system, NAD 83 (1993 Adj.), South Central Zone. All coordinates shown are surface and may be converted to grid by Dividing by TxDOT conversion factor of 1.00013.

NOTE: A parcel plat of even date was prepared in conjunction with this property description.

Compiled by:
Weisser Engineering Company
19500 Park Row, Suite 100
Houston, Texas 77084
December, 2014

CONVENTIONAL SIGNS:

- EXISTING RIGHT-OF-WAY LINE
- ACCESS DENIAL LINE
- PROPOSED RIGHT-OF-WAY LINE
- PROPERTY LINE
- SURVEY LINE

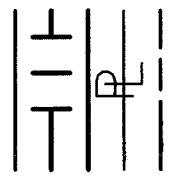

(401)

DENOTES OWNERSHIP No.

(3)

DENOTES BEARING AND DISTANCE NOTE No.

- SET 5/8" I.R. W/TxDOT ALUM. CAP (SEE NOTE 2)
- SET 5/8" I.R. W/TxDOT ALUM. CAP (SEE NOTE 3)
- FOUND 5/8" I.R. W/TxDOT ALUM. CAP
- SET (AS INDICATED)
- FOUND (AS INDICATED)

LEGEND:

- CLERK'S FILE NUMBER
- FILM CODE NUMBER
- OFFICIAL RECORDS OF FORT BEND COUNTY
- FORT BEND COUNTY PLAT RECORDS
- FORT BEND COUNTY DEED RECORDS
- FORT BEND COUNTY COURT RECORDS
- FORT BEND COUNTY DISTRICT COURT RECORDS

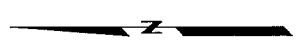

N.T.S.

F.M. 1093

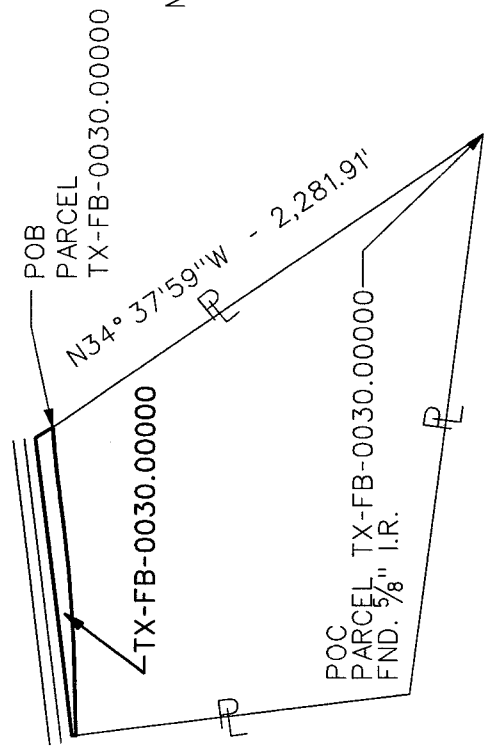

PARENT TRACT INSET

NOTES:

1. A PROPERTY DESCRIPTION OF EVEN DATE WAS PREPARED IN CONJUNCTION WITH THIS PARCEL PLAT.
2. ** THE MONUMENT DESCRIBED AND SET MAY BE REPLACED WITH A TxDOT TYPE II RIGHT-OF-WAY MARKER UPON COMPLETION OF THE HIGHWAY CONSTRUCTION PROJECT UNDER THE SUPERVISION OF A REGISTERED PROFESSIONAL LAND SURVEYOR, EITHER EMPLOYED OR RETAINED BY TxDOT.
3. ALL BEARINGS AND COORDINATES ARE BASED ON THE TEXAS COORDINATE SYSTEM, SOUTH CENTRAL ZONE, NAD 83 (1993 ADJ.). ALL DISTANCES AND COORDINATES SHOWN ARE SURFACE AND MAY BE CONVERTED TO GRID BY DIVIDING BY A COMBINED ADJUSTMENT FACTOR OF 1.00013.
4. ABSTRACTING PERFORMED BY: W.E.C. 07/2014.
5. GROUND SURVEY PERFORMED 03/2012 AND 09/2014.

EXISTING	TAKING AC/SF	REMAINING
73.7497 AC	1,885 AC	71,8647 LT.
Weisser Engineering Co. 19500 Park Row, Suite 100 Houston, Texas 77084 (281) 579 - 7300		
PARCEL PLAT SHOWING PARCEL TX-FB-0030.00000 - F.M. 1093 FORT BEND COUNTY, TEXAS		
DATE: 09/2014 SCALE: N.T.S. JOB No.: EG676		
ROCSJ No.: 1258-03-043 DWG. No.: TX-FB-0030_00000-01		

F.M. 1093

(R.O.W. VARIES)
VOL. 285, PG. 260
VOL. 285, PG. 284
VOL. 285, PG. 287
VOL. 285, PG. 292
F.B.C.D.R.

METROPOLITAN TRANSIT
AUTHORITY OF HARRIS
COUNTY, TEXAS

C.F. NO. 9277986
VOL. 2478, PG. 1664
O.P.R.F.B.C.

FND. 5/8" I.R. W/GAP
STAMPED "BENCHMARK ENG"

N 83° 01' 38" E - 1,328.72'

N 06° 58' 12" W
19.42'

S/O 448+37.15, 128.21' RT

S/O 449+25.44, 129.00' RT

EXISTING R.O.W.

TX-FB-0030.00000

R= 6.436.00'
D= 00° 47' 00"
L= 88.00'
CH= S 87° 52' 16" W-88.00'
RAD. BRG.= S-01° 44' 14" E

R= 6.524.00'
D= 05° 16' 35"
L= 600.79'
CH= S 85° 37' 29" W-600.58'
RAD. BRG.= N 07° 00' 49" W

S/O 451+37.10, 133.89' RT

PROPOSED R.O.W.

S 88° 15' 46" W-213.68'

EXISTING R.O.W.

EXISTING R.O.W.

EXISTING R.O.W.

BASELINE

450+00

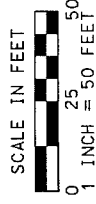

MATCH LINE SEE SHEET 5

CALLLED 56.517 ACRES
TANOUREEN LTD.
C.F. NO. 2005135716
DATE: OCTOBER 31, 2005
O.P.R.F.B.C.

CALLLED 73.7497 ACRES
REID MANAGEMENT COMPANY
C.F. NO. 9524221
DATE: APRIL 24, 1995
O.P.R.F.B.C.

WALTON, HILL & WALTON "A"
SURVEY A-435



19500 Park Row, Suite 100
Houston, Texas 77084
(281) 579 - 7300

PARCEL PLAT SHOWING PARCEL
TX-FB-0030.00000 - F.M. 1093
FORT BEND COUNTY, TEXAS

DATE: 09/20/14 SCALE: 1"= 50'
RCSJ No.: 1258-03-043
JOB No.: EG676
DWG. No.: TX-FB-0030-00000-02

SHEET 5 OF 8

F.M. 1093

(R.O.W. VARIES)
VOL. 285, PG. 260
VOL. 285, PG. 284
VOL. 285, PG. 287
VOL. 285, PG. 292
F.B.C.D.R.

METROPOLITAN TRANSIT
AUTHORITY OF HARRIS
COUNTY, TEXAS
C.F. NO. 9277986
VOL. 2478, PG. 1664
O.P.R.F.B.C.

455+00
BASELINE

N 83° 01' 38" E 1,328.72'

EXISTING R.O.W.

TX-FB-0030.00000

PROPOSED R.O.W.

CALLED 73.7497 ACRES
REID MANAGEMENT COMPANY
C.F. NO. 9524221
DATE: APRIL 24, 1995
O.P.R.F.B.C.

R= 6,524.00'
D= 05° 16' 35"
L= 600.79'
CH= S 85° 37' 29" W-600.58'
RAD. BRG.= N 07° 00' 49" W

WALTON, HILL & WALTON "A"
SURVEY A-435

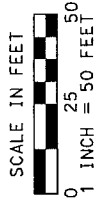

MATCH LINE SEE SHEET 4

MATCH LINE SEE SHEET 6

WEISSER Engineering Co.
19500 Park Row, Suite 100
Houston, Texas 77084
(281) 579 - 7300

PARCEL PLAT SHOWING PARCEL
TX-FB-0030.00000 - F.M. 1093
FORT BEND COUNTY, TEXAS

DATE: 09/2014 SCALE: 1"= 50' JOB No.: FG676
RCSJ No.: 1258-03-043 DWG. No.: TX-FB-0030-00000-03

SHEET 6 OF 8

F.M. 1093

(100' R.O.W.)
VOL. 285, PG. 260
VOL. 285, PG. 284
VOL. 285, PG. 287
VOL. 285, PG. 292
F.B.C.D.R.

METROPOLITAN TRANSIT
AUTHORITY OF HARRIS
COUNTY, TEXAS
C.F. NO. 9277986
VOL. 2478, PG. 1664
O.P.R.F.B.C.

EXISTING R.O.W.

BASELINE

100'

N 83° 01' 38" E - 1,328.72'

EXISTING R.O.W.

TX-FB-0030.00000

S/O 458+94.18, 134.90' RT

PROPOSED R.O.W.

S 82° 59' 11" W - 163.76"

S/O 457+31.99, 137.15' RT

R = 6,524.00'
D = 05° 16' 35"
L = 600.79'
CH = S 85° 37' 29" W - 600.58'
RAD. BRG. = N 07° 00' 49" W

R = 6,436.00'
D = 01° 57' 15"
L = 219.50'
CH = S 83° 57' 49" W - 219.49'
RAD. BRG. = S 05° 03' 34" E

MATCH LINE SEE SHEET 5

MATCH LINE SEE SHEET 7

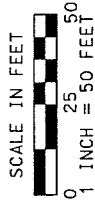

CALLLED 73.7497 ACRES
REID MANAGEMENT COMPANY
C.F. NO. 9524221
DATE: APRIL 24, 1995
O.P.R.F.B.C.

WALTON, HILL & WALTON "A"
SURVEY A-455



19500 Park Row, Suite 100
Houston, Texas 77084
(281) 579 - 7300

PARCEL PLAT SHOWING PARCEL
TX-FB-0030.00000 - F.M. 1093
FORT BEND COUNTY, TEXAS

DATE: 09/2014 SCALE: 1" = 50' JOB No.: FG676
RCSJ No.: 1258-03-043 DWG. No.: TX-FB-0030_00000-04

SHEET 7 OF 8

E.M. 1093

(100' R.O.W.)
VOL. 285, PG. 260
VOL. 285, PG. 284
VOL. 285, PG. 287
VOL. 285, PG. 292
F.B.C.D.R.

METROPOLITAN TRANSIT
AUTHORITY OF HARRIS
COUNTY, TEXAS
C.F. NO. 9277986
VOL. 2478, PG. 1664
O.P.R.F.B.C.

FND. 5/8" I.R. W/CAP
STAMPED "BENCHMARK ENG"

N 83° 01' 38" E
1,328.72'

TX-FB-0030.00000

S/O 461+12.71, 138.06' RT

PROPOSED R.O.W.
S 84° 56' 26" W - 87.03'
R = 6,436.00'
D = 01° 57' 15"
L = 219.50'
CH = S 83° 57' 49" W - 219.49'
RAD. BRG. = S 05° 03' 34" E

S 34° 38' 06" E
90.26'

N 34° 37' 59" W - 2,281.91'

P.O.B.
PARCEL TX-FB-0030.00000
N-13,817, 173.65
E- 2,986, 281.87
S/O 461+99.69, 140.93' RT

CALLED 73.742 ACRES
L.O.B. LIMITED PARTNERSHIP
C.F. NO. 2007114627
DATE: SEPTEMBER 7, 2007
O.P.R.F.B.C.

WALTON, HILL & WALTON "A"
SURVEY A-435

CALLLED 73.7497 ACRES
REID MANAGEMENT COMPANY
C.F. NO. 9524221
DATE: APRIL 24, 1995
O.P.R.F.B.C.
P.O.C.
PARCEL TX-FB-0030.00000
FND. 5/8" I.R.



SCALE IN FEET
0 25 50
1 INCH = 50 FEET

MATCH LINE SEE SHEET 9

WBEISSER Engineering Co.
19500 Park Row, Suite 100
Houston, Texas 77084
(281) 579 - 7300

PARCEL PLAT SHOWING PARCEL
TX-FB-0030.00000 - F.M. 1093
FORT BEND COUNTY, TEXAS

DATE: 09/20/2014 SCALE: 1" = 50' JOB No.: E6676
RCSJ No.: 1258-03-043 IDWG. No.: TX-FB-0030_00000-05

EXHIBIT B-5

County: Fort Bend
Highway: F.M. 1093
Project Limits: F.M. 359 to Hwy. 99 (Grand Parkway)

Property Description for Parcel TX-FB-0031.00000

Being a 0.072 acre (3,148 square feet) parcel of land, out of the Walton, Hill & Walton "A" Survey A-435, Fort Bend County, Texas, and being part of and out of a called 56.517 acre tract of land, described in Deed from Robert L. Dabney, Jr. and William Nelson to Tanoureen, Ltd., A Texas Limited Partnership, filed in the Official Public Records of Fort Bend County (O.P.R.F.B.C.) Fort Bend County, Texas, under Clerk's File No. 2005135716, said 0.072 acre tract being more particularly described as follows:

COMMENCING at a 5/8-inch iron rod found stamped "Benchmark Eng" for a southeast corner of a called 8.568 acre tract of land, described in a Deed from M. A. McDonald, Ewell McDonald, Ola M. McDonald Crandall and Edna A. McDonald to Houston Lighting and Power Company, filed in the Deed Records under Volume 264, Page 431, and for an interior corner of said 56.517 acre tract, thence as follows:

North 06°42'33" West, a distance of 98.31 feet, along a west line of said 56.517 acre tract and along the east line of said 8.568 acre tract, to a 5/8 inch iron rod with cap (stamped "Weisser Eng., Houston, TX") set for the southwest corner and POINT OF BEGINNING of the herein described parcel;

- 1) THENCE, North 06°42'33" West, a distance of 1.70 feet, along the west line of said 56.517 acre tract, along the east line of said 8.568 acre tract and along the west line of the herein described parcel, to the existing south right-of-way line of Metropolitan Transit Authority of Harris County, Texas (50 feet wide) as described in Volume 2478, Page 1664 of the Fort Bend County Deed Records (F.B.C.D.R.), Fort Bend County, Texas and filed in the O.P.R.F.B.C. under Clerk's File No. 9277986, to a 5/8 inch iron rod stamped "Benchmark Eng" found for the northwest corner of the herein described parcel;
- 2) THENCE, North 83°01'38" East, a distance of 351.87 feet, along the south right-of-way line of said Metropolitan Transit Authority of Harris County, Texas and the north line of said 56.517 acre tract, to a 5/8 inch iron rod stamped "Benchmark Eng" found for the northeast corner of the herein described parcel;

EXHIBIT B-5

- 3) THENCE, South $06^{\circ}58'12''$ East, a distance of 19.42 feet, to the proposed south right-of-way of F.M. 1093 (width varies) to a 5/8 inch iron rod with cap (stamped "Weisser Eng., Houston, TX") set for the southeast corner of the herein described parcel and the beginning of a curve to the left;
- 4) THENCE, in a southwest direction, with said curve to the left having a radius of 6,436.00 feet, a central angle of $03^{\circ}08'13''$ and chord which bears South $85^{\circ}54'39''$ West, 352.32 feet, for an arc length of 352.37 feet to a 5/8-inch iron rod with cap stamped "Weisser Eng. Houston, Tx." set in the proposed south right-of-way line of said F.M. 1093 (width varies), to the POINT OF BEGINNING and containing 0.072 acre (725.35 square feet) parcel of land.

NOTE: The Point of Beginning of this description has coordinates of N=13,817,042.21 and E=2,984,562.60; All bearings are based on the Texas State Plane coordinate system, NAD 83 (1993 Adj.), South Central Zone. All coordinates shown are surface and may be converted to grid by Dividing by TxDOT conversion factor of 1.00013.

NOTE: A parcel plat of even date was prepared in conjunction with this property description.

Compiled by:
Weisser Engineering Company
19500 Park Row, Suite 100
Houston, Texas 77084
December, 2014

CONVENTIONAL SIGNS:

- EXISTING RIGHT-OF-WAY LINE
- ACCESS DENIAL LINE
- PROPOSED RIGHT-OF-WAY LINE
- PROPERTY LINE
- SURVEY LINE

(401)

(3)

DENOTES OWNERSHIP No.

DENOTES BEARING AND DISTANCE NOTE No.

SET 5/8" I.R. W/TxDOT ALUM. CAP (SEE NOTE 2)

SET 3/8" I.R. W/TxDOT ALUM. CAP (SEE NOTE 3)

FOUND 5/8" I.R. W/TxDOT ALUM. CAP

SET (AS INDICATED)

FOUND (AS INDICATED)

LEGEND:

- = CLERK'S FILE NUMBER
- = FILM CODE NUMBER
- = OFFICIAL RECORDS OF FORT BEND COUNTY
- = FORT BEND COUNTY PLAT RECORDS
- = FORT BEND COUNTY DEED RECORDS
- = FORT BEND COUNTY COURT RECORDS
- = FORT BEND COUNTY DISTRICT COURT RECORDS

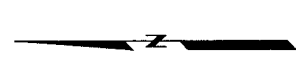

N.T.S.

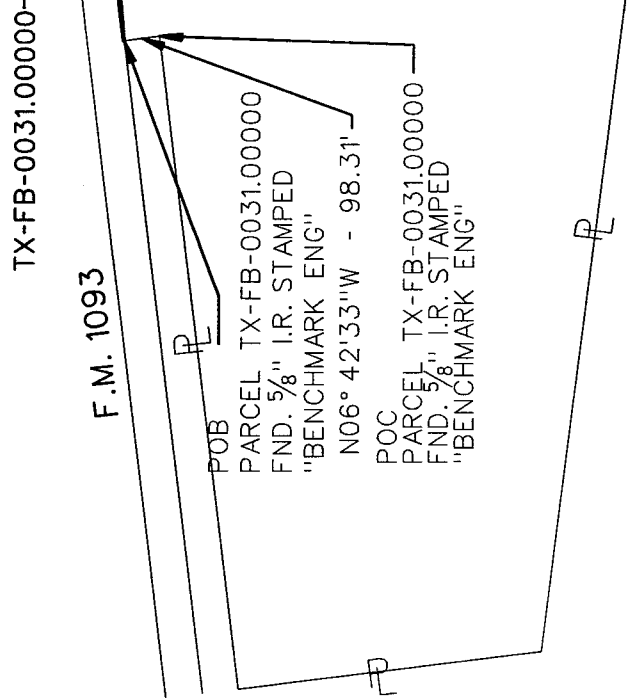

PARENT TRACT INSET

NOTES:

1. A PROPERTY DESCRIPTION OF EVEN DATE WAS PREPARED IN CONJUNCTION WITH THIS PARCEL PLAT.
2. ** THE MONUMENT DESCRIBED AND SET MAY BE REPLACED WITH A TxDOT TYPE II RIGHT-OF-WAY MARKER UPON COMPLETION OF THE HIGHWAY CONSTRUCTION PROJECT UNDER THE SUPERVISION OF A REGISTERED PROFESSIONAL LAND SURVEYOR, EITHER EMPLOYED OR RETAINED BY TxDOT.
3. ALL BEARINGS AND COORDINATES ARE BASED ON THE TEXAS COORDINATE SYSTEM, SOUTH CENTRAL ZONE, NAD 83 (1993 ADJ.). ALL DISTANCES AND COORDINATES SHOWN ARE SURFACE AND MAY BE CONVERTED TO GRID BY DIVIDING BY A COMBINED ADJUSTMENT FACTOR OF 1.00013.
4. ABSTRACTING PERFORMED BY: W.E.C. 07/2014.
5. GROUND SURVEY PERFORMED 03/2012 AND 09/2014.

EXISTING	TAKING AC/SF	REMAINING
56.517 AC	0.072 AC 3,149 SF	56.445 LT.
19500 Park Row, Suite 100 Houston, Texas 77084 (281) 579 - 7300		
PARCEL PLAT SHOWING PARCEL TX-FB-003100000 - F.M. 1093 FORT BEND COUNTY, TEXAS		
DATE: 09/2014 SCALE: N.T.S. JOB No.: EG676		
RCSJ No.: 1258-03-043 DWG. No.: TX-FB-0031_00000-01		

F.M. 1093

(R.O.W. VARIES)
VOL. 285, PG. 260
VOL. 285, PG. 284
VOL. 285, PG. 287
VOL. 285, PG. 292
F.B.C.D.R.

BASELINE

EXISTING R.O.W.

METROPOLITAN TRANSIT
AUTHORITY OF HARRIS
COUNTY, TEXAS
C.F. NO. 9277986

FND. 5/8" I.R. W/CAP
STAMPED "BENCHMARK ENG"
VOL. 2478, PG. 1664
O.P.R.F.B.C.

FND. 5/8" I.R. W/CAP
STAMPED "BENCHMARK ENG"

EXISTING R.O.W. N 83° 01' 38" E 351.87'

PROPOSED R.O.W.

PARCEL TX-FB-0031.00000

N=13,817.042.21
E= 2,984.562.60
S/O 444+80.31, 132.00' RT

R= 6,436.00'
D= 03° 08' 13"
L= 352.37'
CH= S 85° 54' 39" W-352.32'
RAD. BRG.= S 02° 31' 14" E

P.O.C.
PARCEL TX-FB-0031.00000
FND. 5/8" I.R. W/ CAP
STAMPED "BENCHMARK ENG"

WALTON, HILL & WALTON "A"
SURVEY A-435

HOUSTON LIGHTING & POWER
VOL. 264, PG. 431
F.B.C.D.R.
DATE: APRIL 16, 1949

CALLLED 56.517 ACRES
TANOUREEN LTD.
C.F. NO. 2005135716
DATE: OCTOBER 31, 2005
O.P.R.F.B.C. SHEET 4 OF 4

TX-FB-0031.00000
S/O 448+37.15, 128.21' RT
CALLLED 73.7497 ACRES
REID MANAGEMENT COMPANY
C.F. NO. 9524221
DATE: APRIL 24, 1995
O.P.R.F.B.C.

S 06° 58' 12" E
19.42'

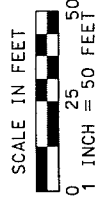
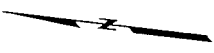

WEISSER Engineering Co.
19500 Park Row, Suite 100
Houston, Texas 77084
(281) 579 - 7300

PARCEL PLAT SHOWING PARCEL
TX-FB-0031.00000 - F.M. 1093
FORT BEND COUNTY, TEXAS

DATE: 09/2014 SCALE: 1" = 50' JOB No.: FG676
RCSJ No.: 1258-03-043 DWG. No.: TX-FB-0031-00000-02

EXHIBIT C

2/28

ASSIGNMENT OF METRO LICENSE AGREEMENT

STATE OF TEXAS §
 §
COUNTY OF FORT BEND §

Fort Bend County Municipal Utility District No. 133 ("Assignor"), a body politic and corporate and a political subdivision of the State of Texas, organized and operating under the provisions of Article XVI, Section 59 of the Texas Constitution and Chapters 49 and 54 of the Texas Water Code, as amended, hereby assigns to Fort Bend County Toll Road Authority ("Assignee"), a local government corporation created by Fort Bend County (the "County"), all of Assignor's rights, obligations, title, and interests in and to the License Agreement between Metropolitan Transit Authority of Harris County, Texas ("METRO") and the Assignor, attached hereto as **Exhibit A**, effective as of the date of Assignor's execution below.

By execution of this Assignment, Assignee hereby accepts such assignment and assumes all of Assignor's rights, obligations, title, and interests in and to the License Agreement.

METRO hereby consents to this Assignment.

By execution of this Assignment, the undersigned agree that the License Agreement is hereby modified to the extent necessary to allow for, authorize, and acknowledge this Assignment and that such Assignment is valid.

EXECUTED to be effective as of the effective date of this Assignment.

[EXECUTION PAGES FOLLOW]

ASSIGNOR

FORT BEND COUNTY MUNICIPAL UTILITY
DISTRICT NO. 133

By: _____

Name: _____

Title: _____

Date: _____

ATTEST:

Name: _____

Title: _____

(SEAL)

ASSIGNEE

FORT BEND COUNTY TOLL ROAD
AUTHORITY

By: _____

Name: _____

Title: _____

Date: _____

ATTEST:

Name: _____

Title: _____

(SEAL)

METRO

METROPOLITAN TRANSIT AUTHORITY OF
HARRIS COUNTY, TEXAS

By: _____

Name: _____

Title: _____

Date: _____

EXHIBIT A

LICENSE AGREEMENT

This License Agreement (the "**Agreement**") is entered into effective as of July 1, 2010, by and between METROPOLITAN TRANSIT AUTHORITY OF HARRIS COUNTY, TEXAS, a public body corporate and politic organized and existing under Chapter 451, Texas Transportation Code ("**Licensor**"), and FORT BEND COUNTY MUNICIPAL UTILITY DISTRICT NO. 133, a body corporate and politic, acting herein by and through its Board of Directors ("**Licensee**"), upon the following terms and conditions:

1. License. Licensor hereby gives to Licensee permission and license (the "**License**") from and after the License Commencement Date (defined in Section 5 below) to use the Property (defined below), at Licensee's sole expense and risk, and on the terms set forth in this Agreement. Licensee stipulates and acknowledges that Licensee has no leasehold, easement or other interest in real property as to the Property.

2. Property. The License applies only to the tract of land (the "**Property**") located in Fort Bend County, Texas, covering an area of approximately 14,833 square feet of land and attached hereto as **EXHIBIT A** and made a part hereof for all purposes.

3. Permitted Uses; Locative Survey.

a. The License to use the Property is limited to only the following purposes and no other (the "**Permitted Uses**"): a temporary roadway for Katy Gaston Road covering a land area of approximately 14,833 SF. The natural drainage pattern of the Property will not be altered and there will be no storage of any kind permitted on the Property. No signs, lighting, fencing or other structures or amenities are allowed.

Use of the Property by Licensee for any purpose other than the Permitted Uses shall be deemed a trespass on Licensor's Property. Use of the Property by any person other than Licensee and Licensee's employees and contractors for any purpose whatsoever shall be deemed a trespass on Licensor's Property. **Use of the Property by Licensee prior to the License Commencement Date for any purpose whatsoever, including but not limited to the Permitted Uses, shall be deemed a trespass on Licensor's Property.**

b. From and after the License Commencement Date of this Agreement, Licensee will construct or caused to be constructed its improvements on the Property consistent with the Permitted Use. Licensee shall complete its improvements within ninety (90) days (the "**Scheduled Completion Date**") after the License Commencement Date.

c. Within thirty (30) days after the Scheduled Completion Date, Licensee shall, at the sole cost and expense of Licensee, deliver to Licensor an "as built" locative survey of the Property and Licensee's improvements situated thereon. Such survey shall be a Category 3, Condition II, Locative Survey, as defined in the *Manual of Practice for Land Surveying in the State of Texas*, as revised. Such locative survey shall be attached hereto as **EXHIBIT B** and made a part hereof for all purposes. Failure to timely deliver the locative survey shall be an event of default hereunder and Licensor shall have the right to terminate this Agreement and the License on two (2) days' notice to Licensee, as set forth in Section 12 below.

4. Fees.

a. On or before the Effective Date, Licensee shall pay to Licensor a one-time, non-refundable administration fee of FIVE HUNDRED AND NO/100 DOLLARS (\$500.00) (the "**Administration Fee**") for processing and administration of this License.

b. So long as this Agreement remains in effect, Licensee shall pay to Licensor an annual, non-refundable, lump sum user fee (the "**Use Fee**") for the License to use of the Property. The initial annual Use Fee shall be due and payable in full on or before the License Commencement Date, and on the first business day in January of each year or partial year that this Agreement is in effect. Payment of the Administration Fee and/or Use Fees shall not be deemed as creating a term for years or any other period of time or term for the License granted herein. This License shall always be terminable at will, the lump sum payment of such fees being required solely for the administrative convenience of Licensor.

c. The initial Use Fee for this License will be 55/100 dollars (\$0.55) per square foot per year. Based on the square footage of the Property as disclosed by **EXHIBIT A** attached hereto, the initial Use Fee is EIGHT THOUSAND ONE HUNDRED FIFTY-EIGHT AND 15/100 Dollars (\$8,158.15). Licensor shall have the right to increase the Use Fee effective as of January 1 of any year during which this Agreement is in effect, by giving Licensee written notice of such increase by December 1 preceding the January 1 on which the increased Use Fee becomes due.

5. License Commencement Date.

a. Licensee's right to use the Property for the Permitted Use pursuant to the License granted in this Agreement shall begin on the date (the "**License Commencement Date**") that all of the following are satisfied: (i) this Agreement has been duly executed by the parties hereto; (ii) the initial plat has been attached hereto as **EXHIBIT A**; and (iii) Licensee has delivered Certificate(s) of Insurance reflecting that Licensee has fully complied with all of Licensor's insurance requirements set forth in **EXHIBIT C** attached hereto and such certificates have been reviewed and reasonably approved by Licensor for compliance with the requirements of **EXHIBIT C**. The License granted in this Agreement shall continue from day to day from and after the License Commencement Date until terminated by either party as provided below.

b. **The parties stipulate and agree that the License Commencement Date is July 1, 2010.**

6. Termination at Will. This Agreement and the License may be terminated by either party hereto at will, at any time and for any reason or for no reason, upon thirty (30) days written notice to the other party (except as otherwise provided in Section 12 below).

7. Surrender of Possession. Unless Licensor gives Licensee its prior written consent to abandon in place any of Licensee's personalty, fixtures or other structures on the Property (the "**Personalty**"), immediately upon notice of termination of the License Licensee will begin work to remove the Personalty from the Property and Licensee shall restore the Property to substantially the same condition in which the Property existed prior to the License

Commencement Date. All such removal and restoration work shall be completed no later than the termination date specified in the termination notice; however, Licensee's obligation to complete the removal and restoration work will survive the termination of the License and this Agreement. If Licensee has not completed such removal of the Personalty and/or restoration of the Property by the specified termination date, Licensor may at its election and at any time after the specified termination date perform the work and promptly upon demand therefore Licensee shall be liable to Licensor for the costs thereof, together with interest thereon at the rate of 18% per year from the date such costs were incurred by Licensor until paid by Licensee.

8. Maintenance. Licensee shall comply with all laws, rules, ordinances and regulations of any municipal, state, county or federal governmental authority or agency, whenever enacted, applicable to Licensee, Licensee's business, the Property or the Permitted Uses, including but not limited to all environmental, health and safety laws and regulations. Licensee, at Licensee's sole cost and expense, shall at all times maintain the Property in good repair and clean, orderly appearance. Without limiting the foregoing, Licensee shall: (i) keep the Property mowed and free and clear of weeds and other debris or rubbish; (ii) obtain all necessary permits and / or licenses required for the Permitted Uses of the Property; (iii) pay all ad valorem taxes, assessments, penalties or fines which may be levied or assessed against any of Licensor's property, including but not limited to the Property, by reason of Licensee's use of the Property; and (iv) pay any and all costs associated with the supply of electricity and other utilities that may be used in connection with Licensee's use of the Property. Licensee shall not: (i) place, nor allow to be placed, any kind of trash, waste, contaminants or hazardous or toxic materials, wastes or substances on or about the Property; or (ii) install, build or construct any improvement or structure on the Property, except for permitted uses without obtaining Licensor's prior written approval for each and every improvement or structure contemplated by Licensee.

9. Insurance. Licensee shall purchase and maintain, for the duration of this Agreement, insurance coverage in form and substance, with limits of liability, and issued by carriers, all of which are satisfactory to Licensor. Such insurance shall conform in all respects to Licensor's requirements, and Licensee shall waive all rights of subrogation, as set forth in **EXHIBIT C** attached to this Agreement entitled **INSURANCE AND WAIVER OF SUBROGATION REQUIREMENTS**.

10. INDEMNIFICATION. **LICENSEE MUST CONTRACTUALLY REQUIRE ITS CONTRACTORS (AND LICENSEE SHALL NOT WAIVE SUCH CONTRACTUAL REQUIREMENTS) TO, DEFEND, INDEMNIFY AND HOLD LICENSOR HARMLESS FROM AND AGAINST ANY AND ALL CLAIMS, CAUSES OF ACTION, SUITS, LOSSES, COSTS, FINES, DAMAGES OR EXPENSES (INCLUDING COSTS OF COURT AND REASONABLE AND NECESSARY ATTORNEYS' FEES) RELATING TO ANY BODILY INJURY OR DEATH OR ANY LOSS OR DAMAGE TO PROPERTY TO ANY PERSON ARISING DIRECTLY OR INDIRECTLY OUT OF THE ENTRY ON THE PROPERTY BY LICENSEE OR ANY LICENSEE PARTIES. THE OBLIGATIONS OF ANY SUCH CONTRACTOR UNDER THIS PARAGRAPH SHALL BE LIMITED TO EVENTS OCCURING DURING THE TERM OF SUCH CONTRACTOR'S CONTRACT WITH LICENSEE AND SHALL SURVIVE THE TERMINATION OR EXPIRATION OF SUCH CONTRACTOR'S CONTRACT FOR A PERIOD OF TWO (2) YEARS. LICENSEE AGREES TO THE FULLEST EXTENT**

ALLOWED BY LAW, TO INDEMNIFY LICENSOR FOR ANY AND ALL DAMAGES ARISING FROM ITS NEGLIGENCE, INCLUDING LICENSOR'S OWN NEGLIGENCE, NEGLIGENT ACT OR OMISSIONS.

11. ASSUMPTION OF ALL RISKS. WITHOUT LIMITING ANYTHING CONTAINED IN THIS AGREEMENT, LICENSEE KNOWINGLY AND VOLUNTARILY ASSUMES ANY AND ALL RISKS, KNOWN AND UNKNOWN, WHICH MAY ARISE DIRECTLY OR INDIRECTLY FROM ITS USE OF THE PROPERTY. LICENSEE SPECIFICALLY AGREES THAT IT WILL NOT SEEK REIMBURSEMENT, DAMAGES OR ANY OTHER KIND OF COMPENSATION FROM LICENSOR, NOR MAKE ANY CLAIMS WHATSOEVER AGAINST LICENSOR, AND LICENSOR SHALL HAVE NO LIABILITY TO LICENSEE OR ANY PERSON ENTERING THE PROPERTY BY, THROUGH OR UNDER LICENSEE'S RIGHTS HEREUNDER, FOR ANY LOSS, COST, DAMAGES, BODILY INJURIES OR DEATH. LICENSOR MAKES NO REPRESENTATIONS OR WARRANTIES OF ANY KIND CONCERNING THE PROPERTY, AND LICENSEE ACCEPTS THE LICENSE TO USE THE PROPERTY "AS IS, WHERE IS" AND WITH ALL FAULTS.

12. Default; Remedies. In the event of Licensee's failure (i) to timely pay the Use Fee and such failure is not cured within five (5) days after the date the Use Fee is due, or (ii) to timely provide or renew the insurance required under **EXHIBIT C**, or (iii) to fully and timely comply with any of the other provisions of this Agreement and such failure is not cured within ten (10) days after notice thereof to Licensee, such failure shall be deemed to be an event of default under this Agreement. In the event of a default hereunder by Licensee, Licensor shall have the right, in addition to any and all other remedies available at law or in equity, and notwithstanding any other provision contained in this Agreement, to terminate this Agreement and the License granted herein, upon two (2) days' notice thereof to Licensee.

13. General Provisions.

a. Notices. Any notice, consent, approval or other communication required or permitted by this Agreement (collectively, a "notice") shall be in writing and shall be deemed sufficiently given if delivered personally or sent by certified mail return receipt requested, postage prepaid to the address provided below for each party, or to any other address as either party may hereafter advise the other party in accordance with this paragraph. Any such notice shall be deemed to have been given as of the date the same is deposited with the US Postal Service when sent by such certified mail, or as of the date received, if delivered other than such certified mail.

b. Non-Assignable. This License is personal to Licensee. Licensee shall be entitled to permit its employees and contractors to enter the Property in connection with Licensee's use of the Property for the Permitted Uses, but Licensee shall not assign or transfer the License, in whole or in part to any person for any purpose including the Permitted Uses. Licensee will not grant or permit encumbrances or mechanics' liens to be placed upon the Property or the License. Any attempted assignment, pledge, or transfer in violation of this paragraph shall be void.

c. Non-Exclusive. The License granted herein is non-exclusive. Licensor shall have the right to grant other licenses, easements, leases, options, contracts for sale, liens, encumbrances and any other interests in real property as to the Property as Licensor deems appropriate in its sole discretion. Licensor shall continue to possess and enjoy all ownership rights in and to the Property. Licensor shall have the right to enter upon the Property at all times, and for any reason.

d. Future Compensation. Licensee will be financially responsible for any and all costs and expenses associated with the design, construction and installation of active railroad crossing equipment including crossing gates, cantilevers-flashers, equipment cabinets and boxes, batteries, approach and island track circuits, roadway track panels, signage, pavement markings and all other equipment and materials to make the subject crossing compliant with Texas MUTCD requirements, as amended.

e. Waivers, Amendments. No waiver by Licensor of any provision of this Agreement shall be effective unless in writing, and no such waiver shall constitute a waiver of any other provision or a subsequent breach of the same provision. This Agreement shall be amended only in writing signed by Licensor and Licensee. No verbal amendments shall be enforceable by or against either party.

f. Governing Law, Venue. This Agreement is governed by the laws of Texas. This Agreement is enforceable only in the state district courts of Harris County, Texas, and each party hereto agrees to submit to the jurisdiction of such courts.

g. Attorney's Fees. In the event of litigation between the parties hereto arising out of this Agreement or Licensee's use of the Property, the prevailing party shall be entitled to costs of litigation, including but limited to reasonable attorneys' fees.

[Remainder of this page intentionally left blank; signature page follows.]

EXECUTED in multiple counterpart originals as of the Effective Date.

LICENSOR:

LICENSEE:

METROPOLITAN TRANSIT AUTHORITY
OF HARRIS COUNTY, TEXAS

FORT BEND COUNTY MUNICIPAL
UTILITY DISTRICT NO. 133

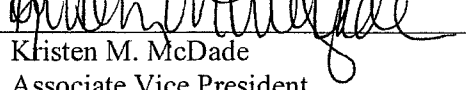
By: 
Name: Kristen M. McDade
Title: Associate Vice President
Real Estate Department

By: 
Name: Richard L. Foster
Title: President, Board of Directors

Address:

Address:

Metropolitan Transit Authority
Attention: Real Estate Department
P.O. Box 61429
Houston, Texas 77208-1429

c/o Allen, Boone, Humphries Robinson
LLP
3200 Southwest Freeway
Suite 2600
Houston, TX 77027
Attn: Jim Boone

EXHIBIT A
PROPERTY DESCRIPTION



called 60.00 acres
F.B.C.C.F. No. 9644828
H.C.C.F. No. V832506

KATY GASTON ROAD
60-foot wide right-of-way

Jerrold Springer
Called 39.1391 Acres
F.B.C.C.F. No. 9754464
L. A. PATILLO
SURVEY, A-307

STATE FARM TO MARKET ROAD 1093
100-foot wide right-of-way

CANAL ROAD
60-foot wide right-of-way

L.O.B. Limited Partnership
Call 28.267 Acres
F.B.C.C.F. No. 2007068297

P.O.C.
Fnd. 5/8" I.R. w/
plastic cap stamped
"BENCHMARK ENGR"
Fnd. 1/2" Oct. Mon. bears
N57°06'42"E, 1.43

P.O.B.
(S)

100-foot wide Metropolitan Transit Authority
of Harris County, Texas Fee Strip
Vol. 2478, Pg. 1664, F.B.C.D.R.

Fnd. 5/8" I.R. w/
plastic cap stamped
"BENCHMARK ENGR"

Katy Gaston Road
Right-of-Way Permit
14,833 Square Feet
0.341 of one Acre

Reid Management Company
Called 73.7497 Acres
F.B.C.C.F. No. 9524221

L.O.B. Limited Partnership
Called 73.742 Acres
F.B.C.C.F. No. 2007114627

WALTON HILL and WALTON "A"
SURVEY, A-435

Proposed
KATY GASTON ROAD

EXHIBIT "A"



Benchmark Engineering Corporation
Consulting Engineers - Planners - Surveyors

2401 Fountainview Suite 500
Houston, Texas 77057 U.S.A. (713)266-9930
Scale: 1"=200' Job No. 04044

**METES AND BOUNDS DESCRIPTION
LAKES OF BELLA TERRA
KATY GASTON ROAD
RIGHT-OF-WAY PERMIT
14,833 SQUARE FEET
FORT BEND COUNTY, TEXAS
Revised April 19, 2010**

All that certain 14,833 square foot (0.341 of one acre) parcel of land located in the Walton Hill and Walton "A" Survey, Abstract Number 435, Fort Bend County, Texas, being out of and a part of 100-foot wide Metropolitan Transit Authority of Harris County, Texas Fee Strip as described by a Deed recorded in Volume 2478, Page 1664 of the Fort Bend County Deed Records (F.B.C.D.R.), and being more particularly described by metes and bounds as follows: (All bearings are referenced to the Texas Coordinate System of 1983, South Central Zone 4204)

COMMENCING FOR REFERENCE at a 5/8-inch iron rod with plastic cap stamped "BENCHMARK ENGR" found in the south line of said Fee Strip at the northwest corner of a called 28.267 acre tract of land as described in a conveyance to L.O.B. Limited Partnership by a Special Warranty Deed recorded under Fort Bend County Clerk's File (F.B.C.C.F.) Number 2007068297 and being the northeast corner of a called 73.742 acre tract of land as described in a conveyance to L.O.B. Limited Partnership by a Special Warranty Exchange Deed recorded under F.B.C.C.F. Number 2007114627, from which a Texas Department of Transportation monument found bears North 31° 06' 42" East, a distance of 1.43 feet;

THENCE, South 83° 02' 01" West, along the north line of said 73.742 acre tract and along the south line of said Fee Strip, a distance of 532.09 feet to a 5/8-inch iron rod with plastic cap stamped "BENCHMARK ENGR" set for the southeast corner and **POINT OF BEGINNING** of the herein described parcel;

THENCE, South 83° 02' 01" West, continuing along the north line of said 73.742 acre tract and along the south line of said Fee Strip, a distance of 142.17 feet to a 5/8-inch iron rod with plastic cap stamped "BENCHMARK ENGR" set for the southwest corner of the herein described parcel, from which a 5/8-inch iron rod with plastic cap stamped "BENCHMARK ENGR" found at the northeast corner of a called 73.7497 acre tract of land as described in a conveyance to Reid Management Company by a Deed recorded under F.B.C.C.F. Number 9524221 and being the northwest corner of said 73.742 acre tract bears South 83° 02' 01" West, a distance of 654.46 feet;

THENCE, North 16° 59' 47" West, a distance of 76.55 feet to a 5/8-inch iron rod with plastic cap stamped "BENCHMARK ENGR" set for an angle point;

THENCE, North 56° 58' 53" West, a distance of 38.31 feet to a 5/8-inch iron rod with plastic cap stamped "BENCHMARK ENGR" set in the south right-of-way (R.O.W.) line of State Farm to Market Road 1093 (100-foot wide) and being in the north line of said Fee Strip for the northwest corner;

THENCE, North 83° 02' 01" East, along the south R.O.W. line of said State Farm to Market Road 1093 and along the north line of said Fee Strip, a distance of 192.17 feet to a 5/8-inch iron rod with plastic cap stamped "BENCHMARK ENGR" set for the northeast corner of the herein described parcel;

THENCE, South 33° 01' 07" West, a distance of 32.13 feet to a 5/8-inch iron rod with plastic cap stamped "BENCHMARK ENGR" set for an angle point;

**Lakes of Bella Terra
Katy Gaston Road
Right-of-Way Permit
14,833 Square Feet
Revised April 19, 2010**

THENCE, South 16° 59' 47" East, a distance of 76.55 feet to the **POINT OF BEGINNING** and containing a computed area of 14,833 square feet (0.341 of one acre) of land.

This description is based on a survey made on the ground of the subject property and is issued in conjunction with a Locative Survey prepared by Benchmark Engineering Corporation, Job No. 04044.



Michael Hoover, R.P.L.S.
Texas Registration No. 5423

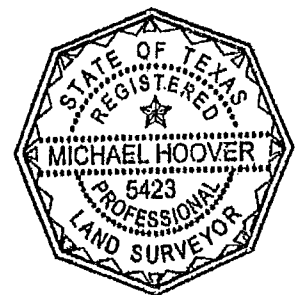

EXHIBIT B

CATEGORY 3, CONDITION II, LOCATIVE SURVEY

LOCATIVE SURVEY WILL BE ATTACHED TO AND MADE APART HEREOF THIS LICENSE AGREEMENT AS EXHIBIT B PURSUANT TO THE TERMS AND CONDITIONS AS SET FORTH IN SECTION 3 (C), PERMITTED USE, LOCATIVE SURVEY.

EXHIBIT C

INSURANCE AND WAIVER OF SUBROGATION REQUIREMENTS

1. Licensee shall purchase and maintain in full force and effect throughout the term of this License Agreement the following types and amounts of insurance:
 - a. General Liability insurance including contractual liability covering Licensee's obligations under the License and with limits of liability not less than \$500,000 each occurrence and \$1,000,000 policy aggregate.
 - b. Automobile Liability covering all owned, hired, and non-owned vehicles (or "any vehicle") in connection with the permitted use of the property under this License Agreement with limits of liability not less than \$1,000,000 combined single limits.
 - c. All additional types and/or amounts of insurance that may be specified in Paragraph 5 below.
2. All insurance policies shall be:
 - a. endorsed to include Licensor as an additional insured with respect to Licensee's use of Licensor's premises under the License;
 - b. primary to any other insurance available to Licensor provided under this License Agreement;
 - c. endorsed to provide thirty (30) days written notice of cancellation, non-renewal, or material change to Licensor; and
 - d. underwritten by an insurance company(ies) having ratings of B++ and VI, or better, as shown in the latest Best's Key Rating Guide.
3. Evidence of such insurance shall be provided to Licensor in the form of an original certificate of insurance showing the number of this License, signed by an authorized agent of the insurance company(ies) and mailed to Real Estate Services, Metropolitan Transit Authority, P.O. Box 61429, Houston, Texas 77208-1429. Receipt and approval of such certificate of insurance by METRO Risk Management must be obtained prior to the License Commencement Date of this License Agreement and/or entry of Licensee onto the Property subject to this License Agreement. Renewal or replacement certificates shall be furnished to Licensor no less than seven (7) days prior to expiration or termination of such policies.
4. Licensee agrees to waive all rights of subrogation or recovery against Licensor, its directors, employees and agents arising out of any claims for injury(ies) or damages resulting from the work performed by or on behalf of Licensee under this Agreement and/or the use of any Licensor's property, including but not limited to the Property, or equipment in the performance of this Agreement.

5. Additional insurance requirements based on Permitted Use as defined in this License Agreement (if none, write "None"): None.

LICENSOR ACKNOWLEDGES RECEIPT OF LICENSEE'S CERTIFICATE(S) OF INSURANCE AND APPROVES SAME AS EVIDENCING LICENSEE'S COMPLIANCE WITH THE FOREGOING REQUIREMENTS:

METROPOLITAN TRANSIT AUTHORITY OF HARRIS COUNTY, TEXAS

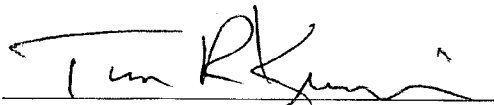
By: 

Name: Tim Kriner

Title: Director of Risk Management

Date: 6/7/2/10

