

To Sherry July 20, 2012

**MEMORANDUM**

6-5-12  
AGENDA ITEM # 29D

**TO:** Judge Robert Hebert **BID #12-052**  
County Judge

**FROM:** Debbie Kaminski  
Assistant Purchasing Agent

**SUBJECT:** Please sign and date the attached contract(s) approved in  
Commissioners Court on June 5, 2012. Thank you.

**DATE:** July 16, 2012

**RETURN TO:** Purchasing Agent *Wheelchair Accessible*  
301 Jackson, Suite 201 *minivans*  
Richmond, Texas 77469

7/20/12 original returned to Cheryl at Purchasing

**Fort Bend County Specification Download Acknowledgment**



**Invitation for Bid  
Purchase of New Wheelchair Accessible Minivan  
BID 12-052**

**VENDORS MUST IMMEDIATELY RETURN THIS FORM BY FAX TO 281-341-8645**

**Vendor Responsibilities:**

- Vendors are responsible to download and complete any addendums.  
(Addendums will be posted on the Fort Bend County Website no later than 48 hours prior to Bid Opening)
- Vendors will submit responses in accordance with requirements stated on cover of document.
- Vendors may not submit responses via email or fax.

TEXAS BUS SALES, INC.

Legal Name of Contracting Company

DIANNE LEDET

Contact Person

1605 WEST 34TH STREET HOUSTON, TX 77018

Complete Mailing Address

(713) 681-3600

(713) 682-8737

Telephone Number

Facsimile Number

DIANNE.LEDET@TEXASBUSSALES.COM

Email Address

*Dianne Ledet*

05-17-12

Signature

Date

*DL*

**Fort Bend County, Texas  
Invitation for Bid**



**Purchase of New Wheelchair Accessible Minivan  
for Fort Bend County  
BID 12-052**

**SUBMIT BIDS TO:**

**Fort Bend County  
Purchasing Department  
Travis Annex  
301 Jackson, Suite 201  
Richmond, TX 77469**

**\*\*NOTE:**

**All correspondence must include the term  
"Purchasing Department" in address to assist in  
proper delivery**

**SUBMIT NO LATER THAN:**

**Thursday, May 17, 2012  
1:30 PM (Central)**

**MARK ENVELOPE:**

**BID 12-052  
Minivan**

***ALL BIDS MUST BE RECEIVED IN COUNTY PURCHASING OFFICE  
BEFORE RECEIVING DATE AND TIME SPECIFIED.  
BIDS RECEIVED WILL THEN BE OPENED AND PUBLICLY READ.  
BIDS RECEIVED AFTER THE SPECIFIED TIME WILL BE RETURNED  
UNOPENED.***

**Results will not be given by phone.  
Results will be provided to bidders in writing  
after Commissioners Court award.**

**Fort Bend County is always conscious  
and extremely appreciative of your effort  
in the preparation of this bid. Requests for  
information must be in writing and directed  
to:  
Debbie Kaminski, CPPB  
Assistant County Purchasing Agent  
[kaminsk@co.fort-bend.tx.us](mailto:kaminskd@co.fort-bend.tx.us)**

Prepared: 04/22/12  
Issued: 05/02/12

A handwritten signature in black ink, appearing to be "DK", is located in the bottom right corner of the page.

**Vendor Information**

TEXAS BUS SALES, INC.

---

Legal Name of Contracting Company

---

Federal ID Number (Company or Corporation) or Social Security Number (Individual)

(713) 681-3600

(713) 682-8737

---

Telephone Number

Facsimile Number

1605 WEST 34TH STREET

---

Complete Mailing Address (for Correspondence)

HOUSTON, TX 77018

---

City, State and Zip Code

---

Complete Remittance Address (if different from above)

---

City, State and Zip Code

DIANNE LEDET, GENERAL MANAGER

---

Authorized Representative and Title (printed)

DIANNE.LEDET@TEXASBUSSALES.COM

---

Authorized Representative's Email Address

*Dianne Ledet*

---

Signature of Authorized Representative

Initials of Bidder

*DL*

**1.0 GENERAL REQUIREMENTS:**

- 1.1 Read this entire document carefully. Follow all instructions. You are responsible for fulfilling all requirements and specifications. Be sure you understand them.
- 1.2 General Requirements apply to all advertised bids; however, these may be superseded, whole or in part, by the scope, special requirements, specifications, special specifications or other data contained herein.
- 1.3 Governing Law: Bidder is advised that these requirements shall be fully governed by the laws of the State of Texas and that Fort Bend County may request and rely on advice, decisions and opinions of the Attorney General of Texas and the County Attorney concerning any portion of these requirements.
- 1.4 Bid Form Completion: Fill out, sign, and return to the Fort Bend County Purchasing Department ONE (1) complete bid form. An authorized representative of the bidder must sign the Contract Sheet. The contract will be binding only when signed by the County Judge, Fort Bend County and a purchase order authorizing the item(s) desired has been issued. The use of liquid paper is not acceptable and may result in the disqualification of bid. If an error is made, vendor must draw a line through error and initial each change.
- 1.5 Bid Returns: Bidders must return all completed bids to the Fort Bend County Purchasing Department at 301 Jackson, Suite 301, Suite 201, Richmond, Texas 77469 no later than 1:30 P.M. on the date specified. Late bids will not be accepted. Bids must be submitted in a sealed envelope, addressed as follows: Fort Bend County Purchasing Agent, Travis Annex, 301 Jackson, Suite 201, Richmond, Texas 77469.
- 1.6 Governing Forms: In the event of any conflict between the terms and provisions of these requirements and the specifications, the specifications shall govern. In the event of any conflict of interpretation of any part of this overall document, Fort Bend County's interpretation shall govern.
- 1.7 Addendums: When specifications are revised, the Fort Bend County Purchasing Department will issue an addendum addressing the nature of the change. Bidders must sign and include it in the returned bid package.

- 1.8 **Hold Harmless Agreement:** Contractor shall indemnify and hold Fort Bend County harmless from all claims for personal injury, death and/or property damage arising from any cause whatsoever, resulting directly or indirectly from contractor's performance. Contractor shall procure and maintain, with respect to the subject matter of this bid, appropriate insurance coverage including, as a minimum, public liability and property damage with adequate limits to cover contractor's liability as may arise directly or indirectly from work performed under terms of this bid. Certification of such coverage must be provided to the County upon request.
- 1.9 **Waiver of Subrogation:** Bidder and bidder's insurance carrier waive any and all rights whatsoever with regard to subrogation against Fort Bend County as an indirect party to any suit arising out of personal or property damages resulting from bidder's performance under this agreement.
- 1.10 **Severability:** If any section, subsection, paragraph, sentence, clause, phrase or word of these requirements or the specifications shall be held invalid, such holding shall not affect the remaining portions of these requirements and the specifications and it is hereby declared that such remaining portions would have been included in these requirements and the specifications as though the invalid portion had been omitted.
- 1.11 **Bonds:** If this bid requires submission of bid guarantee and performance bond, there will be a separate page explaining those requirements. Bids submitted without the required bid bond or cashier's checks are not acceptable.
- 1.12 **Taxes:** Fort Bend County is exempt from all federal excise, state and local taxes unless otherwise stated in this document. Fort Bend County claims exemption from all sales and/or use taxes under Chapter 20, Title 122a, Vernon's Texas Civil Statutes, as amended. Texas Limited Sales Tax Exemption Certificates will be furnished upon written request to the Fort Bend County Purchasing Department.
- 1.13 **Fiscal Funding:** A multi-year lease or lease/purchase arrangement (if requested by the specifications), or any contract continuing as a result of an extension option, must include fiscal funding out. If, for any reason, funds are not appropriated to continue the lease or contract, said lease or contract shall become null and void. After expiration of the lease, leased equipment shall be removed by the bidder from the using department without penalty of any kind or form to Fort Bend County. All charges and physical activity related to delivery, installation, removal and redelivery shall be the responsibility of the bidder.



- 1.14 Pricing: Prices for all goods and/or services shall be firm for the duration of this contract and shall be stated on the bid sheet. Prices shall be all inclusive. No price changes, additions, or subsequent qualifications will be honored during the course of the contract. All prices must be written in ink or typewritten. Pricing on all transportation, freight, and other charges are to be prepaid by the contractor and included in the bid prices. If there are any additional charges of any kind, other than those mentioned above, specified or unspecified, bidder MUST indicate the items required and attendant costs or forfeit the right to payment for such items.
- 1.15 Silence of Specifications: The apparent silence of specifications as to any detail, or the apparent omission from it of a detailed description concerning any point, shall be regarded as meaning that only the best commercial practice is to prevail and that only material and workmanship of the finest quality are to be used. All interpretations of specifications shall be made on the basis of this statement. The items furnished under this contract shall be new, unused of the latest product in production to commercial trade and shall be of the highest quality as to materials used and workmanship. Manufacturer furnishing these items shall be experienced in design and construction of such items and shall be an established supplier of the item bid.
- 1.16 Supplemental Materials: Bidders are responsible for including all pertinent product data in the returned bid package. Literature, brochures, data sheets, specification information, completed forms requested as part of the bid package and any other facts which may affect the evaluation and subsequent contract award should be included. Materials such as legal documents and contractual agreements, which the bidder wishes to include as a condition of the bid, must also be in the returned bid package. Failure to include all necessary and proper supplemental materials may be cause to reject the entire bid.
- 1.17 Material Safety Data Sheets: Under the "Hazardous Communication Act", commonly known as the "Texas Right To Know Act", a bidder must provide to County and using departments, with each delivery, material safety data sheets, which are, applicable to hazardous substances defined in the Act. Bidders are obligated to maintain a current, updated file in the Fort Bend County Purchasing Department. Failure of the bidder to maintain such a file will be cause to reject any bid applying thereto.
- 1.18 Name Brands: Specifications may reference name brands and model numbers. It is not the intent of Fort Bend County to restrict these bids in such cases, but to establish a desired quality level of merchandise or to meet a pre-established standard due to like existing items. Bidders may offer items of equal stature and the burden of proof of such stature rests with them. Fort Bend County shall act as sole judge in determining equality and acceptability of products offered.

- 1.19 Color Selection: Determination of colors of materials is a right reserved by the using department unless otherwise specified in the bid. Unspecified colors shall be quoted as standard colors, not colors, which require up charges or special handling. Unspecified fabrics or vinyl should be construed as medium grade. If bidder fails to get color/material approvals prior to delivery of merchandise, the using department may refuse to accept the items and demand correct shipment without penalty, subject to other legal remedies.
- 1.20 Evaluation: Evaluation shall be used as a determinant as to which bid items or services are the most efficient and/or most economical for the County. It shall be based on all factors, which have a bearing on price and performance of the items in the user environment. All bids are subject to tabulation by the Fort Bend County Purchasing Department and recommendation to Fort Bend County Commissioners Court. Compliance with all bid requirements, delivery and needs of the using department are considerations in evaluating bids. Pricing is NOT the only criteria for making a recommendation. The Fort Bend County Purchasing Department reserves the right to contact any bidder, at any time, to clarify, verify or request information with regard to any bid.
- 1.21 Inspections: Fort Bend County reserves the right to inspect any item(s) or service location for compliance with specifications and requirements and needs of the using department. If a bidder cannot furnish a sample of a bid item, where applicable, for review, or fails to satisfactorily show an ability to perform, the County can reject the bid as inadequate.
- 1.22 Testing: Fort Bend County reserves the right to test equipment, supplies, material and goods bid for quality, compliance with specifications and ability to meet the needs of the user. Demonstration units must be available for review. Should the goods or services fail to meet requirements and/or be unavailable for evaluation, the bid is subject to rejection.
- 1.23 Disqualification of Bidder: Upon signing this bid document, a bidder offering to sell supplies, materials, services, or equipment to Fort Bend County certifies that the bidder has not violated the antitrust laws of this state codified in section 15.01, et seq., Business & Commerce Code, or the federal antitrust laws, and has not communicated directly or indirectly the bid made to any competitor or any other person engaged in such line of business. Any or all bids may be rejected if the County believes that collusion exists among the bidders. Bids in which the prices are obviously unbalanced may be rejected. If multiple bids are submitted by a bidder and after the bids are opened, one of the bids is withdrawn, the result will be that all of the bids submitted by that bidder will be withdrawn; however, nothing herein prohibits a vendor from submitting multiple bids for different products or services.



- 1.24 Awards: Fort Bend County reserves the right to award this contract on the basis of lowest and best bid in accordance with the laws of the State of Texas, to waive any formality or irregularity, to make awards to more than one bidder, to reject any or all bids. In the event the lowest dollar bidder meeting specifications is not awarded a contract, the bidder may appear before the Commissioners Court and present evidence concerning his responsibility. An award is final only upon formal execution by the Fort Bend County Commissioners Court or the Fort Bend County Purchasing Agent. Fort Bend County reserves the right to withdraw any award until execution by the proper authority.
- 1.25 Assignment: The successful vendor may not assign, sell or otherwise transfer this contract without written permission of Fort Bend County Commissioners Court.
- 1.26 Term Contracts: If the contract is intended to cover a specific time period, said time will be given in the specifications under scope.
- 1.27 Maintenance: Maintenance required for equipment bid should be available in Fort Bend County by a manufacturer authorized maintenance facility. Costs for this service shall be shown on the bid sheet as requested or on a separate sheet, as required. If Fort Bend County opts to include maintenance, it shall be so stated in the purchase order and said cost will be included. Service will commence only upon expiration of applicable warranties and should be priced accordingly.
- 1.28 Contract Obligation: Fort Bend County Commissioners Court must award the contract and the County Judge or other person authorized by the Fort Bend County Commissioners Court must sign the contract before it becomes binding on Fort Bend County or the bidders. Department heads are not authorized to sign agreements for Fort Bend County. Binding agreements shall remain in effect until all products and/or services covered by this purchase have been satisfactorily delivered and accepted.
- 1.29 Title Transfer: Title and Risk of Loss of goods shall not pass to Fort Bend County until Fort Bend County actually receives and takes possession of the goods at the point or points of delivery. Receiving times may vary with the using department. Generally, deliveries may be made between 8:30 a.m. and 4:00 p.m., Monday through Friday. Bidders are advised to consult the using department for instructions. The place of delivery shall be shown under the "Special Requirement" section of this bid document and/or on the Purchase Order as a "Ship To:" address.



- 1.30 **Purchase Order and Delivery:** The successful bidder shall not deliver products or provide services without a Fort Bend County Purchase Order, signed by an authorized agent of the Fort Bend County Purchasing Department. The fastest, most reasonable delivery time shall be indicated by the bidder in the proper place on the bid sheet. Any special information concerning delivery should also be included, on a separate sheet, if necessary. All items shall be shipped F.O.B. inside delivery unless otherwise stated in the specifications. This shall be understood to include bringing merchandise to the appropriate room or place designated by the using department. Every tender or delivery of goods must fully comply with all provisions of these requirements and the specifications including time, delivery and quality. Nonconformance shall constitute a breach, which must be rectified prior to expiration of the time for performance. Failure to rectify within the performance period will be considered cause to reject future deliveries and cancellation of the contract by Fort Bend County without prejudice to other remedies provided by law. Where delivery times are critical, Fort Bend County reserves the right to award accordingly.
- 1.31 **Contract Extension:** Extensions may be made only by written agreement between Fort Bend County and the bidder. Any price escalations are limited to those stated by the bidder in the original bid.
- 1.32 **Termination:** Fort Bend County reserves the right to terminate the contract for default if Seller breaches any of the terms therein, including warranties of bidder or if the bidder becomes insolvent or commits acts of bankruptcy. Such right of termination is in addition to and not in lieu of any other remedies, which Fort Bend County may have in law or equity. Default may be construed as, but not limited to, failure to deliver the proper goods and/or services within the proper amount of time, and/or to properly perform any and all services required to Fort Bend County's satisfaction and/or to meet all other obligations and requirements. Contracts may be terminated without cause upon thirty (30) days written notice to either party unless otherwise specified.
- 1.33 **Recycled Materials:** Fort Bend County encourages the use of products made of recycled materials and shall give preference in purchasing to products made of recycled materials if the products meet applicable specifications as to quantity and quality. Fort Bend County will be the sole judge in determining product preference application.
- 1.34 **Interlocal Participation:** Additional governmental entities, within Fort Bend County, may purchase from this bid. Vendor agrees to accept purchase orders from those participating entities and to invoice each entity separately.



- 1.35 Escalation Clause: Successful bidder may apply for a price increase to the Fort Bend County Commissioners Court. Price increase will be the amount increased to the vendor from his supplier. Written documentation of the increase must be provided to the Purchasing Agent. No application for a price increase may be submitted within the first four (4) months of this contract. Increases of more than 25% of the original bid price will not be considered.

## **2.0 TERMS AND CONDITIONS:**

- 2.1 Seller to Package Goods: Seller will package goods in accordance with good commercial practice. Each delivery container shall be clearly and permanently marked as follows (a) Seller's name and address; (b) Consignee's name, address and purchase order number and the bid number if applicable; (c) Container number and total number of containers (e.g. box 1 of 4 boxes); and (d) the number of the container bearing the packing slip. Seller shall bear cost of packaging unless otherwise provided. Goods shall be suitably packed to secure lowest transportation costs and to conform to requirements of common carriers and any applicable specifications. Fort Bend County's count or weight shall be final and conclusive on shipments not accompanied by packing list.
- 2.2 Shipment Under Reservation Prohibited: Seller is not authorized to ship goods under reservation and no tender of a bill of lading will operate as a tender of goods.
- 2.3 Title and Risk of Loss: The title and risk of loss of the goods shall not pass to the County until a County employee actually receives and takes possession of the goods at the point or points of delivery.
- 2.4 Delivery Terms: F.O.B. Destination Freight Prepaid, Inside Delivery, unless delivery terms are specified otherwise on Purchase Order.
- 2.5 No Replacement of Defective Tender: Every tender or delivery of goods must fully comply with all provisions of the Purchase Order as to time of delivery, quality and the like. If a tender is made which does not fully conform, this shall constitute a breach and Seller shall not have the right to substitute a conforming tender.
- 2.6 Place of Delivery: The place of delivery shall be that set forth in the block of the purchase order entitled "Ship To". Any change thereto shall be effective by modification as provided for in Clause number 2.20 "Modifications", hereof. The terms of this agreement are "no arrival, no sale", at the discretion of Fort Bend County.



2.7 Invoices and Payments:

2.7.1 Seller shall submit separate invoices, in duplicate. Invoices shall indicate the purchase order number and the bid number if applicable. Invoices shall be itemized and transportation charges, if any, shall be listed separately. A copy of the bill of lading, and the freight waybill when applicable should be attached to the invoice.

2.7.2 Fort Bend County's obligation is payable only and solely from funds available for the purpose of this purchase. Lack of funds shall render the order null and void to the extent funds are not available and any delivered but unpaid goods will be returned to Seller by the county.

2.7.3 Do not include Federal Excise, State, or City Sales Tax. Fort Bend County is a tax-exempt governmental entity.

2.8 Gratuities: Fort Bend County may, by written notice to the Seller, cancel any order without liability, if it is determined by the County that gratuities, in the form of entertainment, gifts, or otherwise were offered or given by the Seller, or any agent or representative of the Seller to any officer or employee of Fort Bend County with a view toward securing an order. In the event an order is canceled by the County pursuant to this provision, the County shall be entitled, in addition to any other rights and remedies, to recover or withhold the amount of the cost incurred by Seller in providing such gratuities.

2.9 Special Tools and Test Equipment: If the price stated on the face of an order includes the cost of any special tooling or special test equipment fabricated or required by Seller for the purpose of filing this order, such special tooling equipment and any process sheets related thereto shall become the property of the County and to the extent feasible shall be identified by the Seller as such.

2.10 Warranty/Price:

2.10.1 The price to be paid by the County shall be that contained in Seller's quote or bid which Seller warrants to be no higher than Seller's current prices on orders by others for products of the kind and specification covered by an order for similar quantities under similar or like conditions and methods of purchase. In the event Seller breaches this warranty the prices of the items shall be reduced to the Seller's current prices on orders by others. Fort Bend County may cancel this contract without liability.



- 2.10.2 The Seller warrants that no person or selling agency has been employed or retained to solicit or secure any County order based upon any agreement or understanding for commission, percentage, brokerage, or contingent fee excepting bona fide employees of bona fide established commercial or selling agencies maintained by the Seller for the purpose of securing business. A breach or violation of this warranty gives the County the right, in addition to any other right or rights, to cancel this contract without liability.
- 2.11 Warranty Product: Seller shall not limit or exclude any implied warranties and any attempt to do so shall render an order voidable at the option of the County. Seller warrants that the goods furnished will conform to the specifications, drawings, and description listed in the bid invitation and purchase order as applicable, and to the sample(s) furnished by Seller if any. In the event of a conflict between the specifications, drawings, and descriptions, the specifications shall govern.
- 2.12 Safety Warranty: Seller warrants that the product sold to Fort Bend County shall conform to the standards promulgated by the U.S. Department of Labor under the Occupational Safety and Health Act of 1970. In the event the product does not conform to OSHA standards, the County may return the product for correction or replacement at the Seller's expense. In the event Seller fails to make the appropriate correction within 10 days, correction made by the County will be at Seller's expense.
- 2.13 No Warranty by Fort Bend County Against Infringements: As part of a contract for sale Seller agrees to ascertain whether goods manufactured in accordance with the specifications will give rise to the rightful claim of any third person by way of infringement. Fort Bend County makes no warranty that the production of goods according to the specification will not give rise to such a claim and in no event shall Fort Bend County be liable to Seller for indemnification in the event the Seller is sued on the grounds of infringement or the like. If Seller is of the opinion that an infringement will result, he will notify Fort Bend County to this effect in writing within two days after the receiving Purchase Order. If the County does not receive notice and is subsequently held liable for the infringement, Seller will defend and save the County harmless. If Seller in good faith ascertains that production of the goods in accordance with the specifications will result in infringement, this contract shall be null and void except that the County will pay Seller the reasonable cost of his search as to infringements.
- 2.14 Right of Inspection: The County shall have the right to inspect the goods at delivery before accepting them.

Handwritten signature or initials in the bottom right corner of the page.

- 2.15 Cancellation: Fort Bend County shall have the right to cancel for default all or any part of the undelivered portion of an order if Seller breaches any of the terms hereof including warranties of Seller, or if the Seller becomes insolvent or files for protection under the bankruptcy laws. Such rights of cancellation are in addition to and not in lieu of any other remedies, which Fort Bend County may have in law or equity.
- 2.16 Termination: The performance of work under a Purchase Order may be terminated in whole or in part by the County in accordance with this provision. Termination of work there under shall be effected by the delivery to the Seller of a "Notice of Termination" specifying the extent to which performance of work under the order is terminated and the date upon which such termination becomes effective. Such right of termination is in addition to and not in lieu of rights of Fort Bend County set forth in Section 2.15.
- 2.17 Force Majeure: Force Majeure means a delay encountered by a party in the performance of its obligations under this Agreement, which is caused by an event beyond the reasonable control of that party. Without limiting the generality of the foregoing, "Force Majeure" shall include but not be restricted to the following types of events: acts of God or public enemy; acts of governmental or regulatory authorities; fires, floods, epidemics or serious accidents; unusually severe weather conditions; strikes, lockouts, or other labor disputes; and defaults by subcontractors. In the event of a Force Majeure, the affected party shall not be deemed to have violated its obligations under this Agreement, and the time for performance of any obligations of that party shall be extended by a period of time necessary to overcome the effects of the Force Majeure, provided that the foregoing shall not prevent this Agreement from terminating in accordance with the termination provisions. If any event constituting a Force Majeure occurs, the affected party shall notify the other parties in writing, within twenty-four (24) hours, and disclose the estimated length of delay, and cause of the delay.
- 2.18 Assignment-Delegation: No right or interest in an order shall be assigned or delegation of any obligation made by Seller without the written permission of Fort Bend County. Any attempted assignment or delegation by Seller shall be wholly void and totally ineffective for all purposes unless made in conformity with this paragraph.
- 2.19 Waiver: No claim or right arising out of a breach of any contract can be discharged in whole or in part by a waiver or renunciation of the claim or right unless the waived or renunciation is supported by consideration and is in writing signed by the aggrieved party.
- 2.20 Modification: A Purchase Order can be modified or rescinded only by a writing signed by both of the parties or their duly authorized agents.



- 2.21 Parol Evidence: This writing is intended by the parties as a final expression of their agreement and is intended also as a complete and exclusive statement of the terms of this agreement. No course of prior dealings between the parties and no usage of the trade shall be relevant to supplement or explain any terms rendered under this agreement and shall not be relevant to determine the meaning of this agreement even though the accepting or acquiescing party has knowledge of the performance and opportunity for objection. Whenever a term defined by the Uniform Commercial Code is used in this agreement, the definition contained in the Code is to control.
- 2.22 Applicable Law: This agreement shall be governed by the Uniform Commercial Code. Whenever the term "Uniform Commercial Code" is used it shall be construed as meaning the Uniform Commercial Code as adopted in the State of Texas and in effective on the date of the purchase order.
- 2.23 Advertising: Seller shall not advertise or publish, without the County's prior consent the fact that Fort Bend County has entered into any contract, except to the extent necessary to comply with proper requests for information from an authorized representative of the federal, state, or local government.
- 2.24 Right to Assurance: Whenever the County in good faith has reason to question the other party's intent to perform. The County may demand that the other party give written assurance of his intent to perform. In the event that a demand is made and no assurance is given within five (5) days, the County may treat this failure as an anticipatory repudiation of the contract.
- 2.25 Venue: Both parties agree that venue for any litigation arising from this contract shall lie in Richmond, Fort Bend County, Texas.
- 2.26 Prohibition Against Personal Interest in Contracts: No officer or employee of the County shall have a financial interest, direct or indirect, in any contract with the County, or shall be financially interested, directly or indirectly, in the sale to the County of any land, materials, supplies, or service, except on behalf of the County as an officer or employee. Any willful violation of this section shall constitute malfeasance in office, and any officer or employee guilty thereof shall be subject to disciplinary action under applicable laws, statutes and codes of the State of Texas. Any violation of this section, with the knowledge, expressed or implied of the person or corporation contracting with the County shall render the contract involved voidable by the County Commissioners Court.

**3.0 SCOPE:**

It is the intent of Fort Bend County to purchase five (5) or more wheelchair accessible, ADA compliant minivan from one (1) vendor, which meet or exceed the specifications contained herein.



**4.0 BID FORM COMPLETION:**

**Fill out, initial each page, SIGN CONTRACT SHEET, and return to the Fort Bend County Purchasing Department ONE (1) complete bid form. An authorized representative of the bidder MUST sign the contract sheet.** The contract will be binding only when signed by the County Judge, Fort Bend County and a purchase order authorizing the item(s) desired has been issued. The use of liquid paper is **NOT** acceptable and may result in the disqualification of bid. If an error is made, vendor **MUST** draw a line through error and initial each change.

**5.0 DELIVERY:**

Delivery of minivan(s) ordered must be completed within one hundred twenty (120) calendar days after receipt of purchase order issued by the Fort Bend County Purchasing Agent. Delivery must be made to the Fort Bend County Vehicle Maintenance Department at 230 Legion Drive, Richmond, Texas 77469. Invoice, title application, application for license plates, and all other paperwork must be sent to the ordering department stated on the purchase order. All titles should read: Fort Bend County c/o Purchasing Department, 301 Jackson, Richmond, Texas 77469.

**6.0 REQUIRED EQUIPMENT:**

6.1 PASSENGER VANS. LIGHT-DUTY: Unless otherwise specified, all units shall be furnished complete with standard equipment and factory-installed accessories as listed in the manufacturer's printed literature for the models specified herein. The below items are minimum requirements for the models specified herein, and shall be provided whether shown as optional or standard equipment by the manufacturer. Bidder must state the make and model bid in the space provided. Failure to do so may result in disqualification of bid. Unit bid must meet or exceed the following specifications. All units to be new, current production models.

6.2 These additional requirements listed below are in lieu of or in addition to, the following general requirements for Light Duty Passenger Vans:

6.2.1 Body:

- 6.2.1.1 Air Bags: Driver's side. Dual, if available.
- 6.2.1.2 Air Conditioning: Manufacturer's standard.
- 6.2.1.3 Arm Rests, Door-Mounted: Both right and left arm rests are required.
- 6.2.1.4 AM/FM Radio: Manufacturer's standard.
- 6.2.1.5 Auxiliary Power Outlet: 12 volt.
- 6.2.1.6 Headliner: Full length.
- 6.2.1.7 Heater and Defroster:
- 6.2.1.8 Power Package: Includes power windows, power locks, power mirrors, cruise control, and tilt steering wheel.

- 6.2.1.9 Seat, Cloth: Where applicable foldaway seats shall be provided over the wheelchair tie down stations for ambulatory passengers when wheelchair stations are not in use.
- 6.2.1.10 Side Panels, Interior: Rigid material with a durable finish such as plastic shall be installed on all walls and doors.
- 6.2.1.11 Sun Visor: Dual.
- 6.2.1.12 Tinted Glass: Agency will indicate on purchase order maximum windshield/window tint required.
- 6.2.1.13 Windows, Passenger: Required (factory installed, if available) for each row of seats.
- 6.2.1.14 Windshield Wipers: Dual electric 2-speed type with intermittent feature windshield washers.

6.2.2 Chassis:

- 6.2.2.1 Automatic Transmission.
- 6.2.2.2 Brakes, ABS, required, Manufacturer's standard, front disc, 2- or 4-wheel.
- 6.2.2.3 Bumpers: Manufacturer's standard front and rear.
- 6.2.2.4 Ground Ratings: As required for the GVWR certified.
- 6.2.2.5 Spare Wheel and Tire: For manufacturer's standard tire, shipped loose - spare wheel and tire shall be IDENTICAL IN BRAND NAME, TYPE, AND SIZE OF TIRE to those on the vehicle.
- 6.2.2.6 Tires, Including Spare, If Conventional Type: Steel-belted radial-type tubeless tires (all tires shall be identical).

6.2.3 Original Equipment Manufacturer (OEM) specifications: Small size extended van, 6-cylinder, 7 and 8 passenger:

ITEM	Min. Reqs.	MV - 1	Dodge Grand Caravan (common OEM platform for conversion minivan)
Wheelbase, inches	119.3	122	121.2
Length, Overall inches	200.5	205	202.5
GVWR pounds	5,820	6,600	7,000
Engine, Displacement, liters	3.3 L V-6	4.6 L V-8	3.3L V-6, FFV
Transmission, Automatic	Automatic	A40D	A40D

6.2.4 Additional equipment: The following equipment is also required in addition to that required above:

- 6.2.4.1 Cargo Door: Right side, Sliding .
- 6.2.4.2 Rearview Mirrors: Largest factory-installed available.

6.2.5 ADA features:

- 6.2.5.1 Vehicles must meet all ADA requirements under normal operating conditions. ADA ramp slope requirements shall not be met by equipping the vehicle with "low profile" tires.
- 6.2.5.2 Wheelchair Entry - The wheelchair entry shall provide a minimum thirty-one and one half inches (31 1/2") clear opening width and a minimum fifty-six nominal inches (56") door opening height from ramp to door header.
- 6.2.5.3 Wheel Chair Ramp - Manual, fold-up, formed aluminum ramp with non-skid surface. When the ramp is stored, ambulatory passengers shall be able to enter/exit from lowered floor without using ramp. Floor shall be a maximum eleven inches (11") from the ground. Ramp shall be thirty inches (30") minimum useable width and the ramp length shall be forty-eight inches (48") minimum. Usable width means a 28 1/2" width measured at the platform and a 30" minimum width measured at 2" above the platform through the door onto the floor of the van.
- 6.2.5.4 Wheel Chair Securement – The vehicle shall have forward facing wheel chair positions as indicated in the floor plan. Each wheelchair position shall be provided with a set of restraint devices (Q-Straint "QRT Max", Sure-Lok "Titan", or approved equal) that will secure the occupied wheelchair and secure the wheelchair passenger while in the wheelchair. These devices shall be adjustable to accommodate varying track widths of wheelchairs. Each wheelchair shall have a four (4) point securement (2 front , 2 back) in the vehicle with recessed anchor points of sufficient strength to secure a wheelchair.
- 6.2.5.5 Forward Facing Track & Belt System.  
A four-point attachment system shall be used consisting of four separate belts. Two of the buckles shall be tensioning devices. A minimum of two tracks shall be placed parallel to each other and perpendicular to the direction the wheelchair faces. The tracks shall be securely mounted to the vehicle in such a way as to ensure the track will not pull away from the van floor or shift position under anticipated loads. A separate 3-point chest/lap belt with height adjuster shall be made available for fastening passenger in place. No anchoring points shall project more than one-eighth inch (1/8") above the finished floor.

- 6.2.5.6 Floor mounted tracks. Floor mounted tracks shall be a series of horizontal tracks of minimum dimensions thirty inches (30") wide, spaced a minimum of forty-two (42") fore and aft.
- 6.2.5.7 These tracks may be recessed mounted in the kick panel, floor, and firewall with three-eighths inch (3/8") diameter, SAE Grade 5, bolts, washers, and self-locking nuts with National Fine Threads. Bolts shall be installed on each side flange of the track and spaced not greater than twelve inches (12") apart.
- 6.2.5.8 These tracks may be welded in the kick panel, floor, and firewall
- 6.2.5.9 Where mounting bolts do not pierce or attach through the vehicle frame, sub-frame, body posts or equivalent metal structure, a reinforcement metal plate not less than one-sixteenth inch (1/16") thick is required.
- 6.2.5.10 Strap Assemblies. There shall be four (4) strap assemblies for each wheelchair position to secure the wheelchair to the tracks. Each strap assembly shall consist of a fixed-end strap, adjustable-end strap with tensioning device, closed hook and an end fitting.
- 6.2.5.11 The fixed-end strap shall be one and three-quarter inches (1-3/4") wide, five inches (5") long, with a strength rating of not less than two thousand five hundred (2,500) pounds. One end of this strap shall be secured to a tensioning mechanism. The other end of the strap shall be connected to an end fitting used to fasten the strap to the floor track. This fitting shall have a spring-loaded release.
- 6.2.5.12 The adjustable-end strap shall be one inch (1") wide, twenty inches (20") long, with a strength rating of not less than two thousand five hundred (2,500) pounds. One end of the strap shall be secured to a closed hook. This strap shall be used to fasten the wheelchair to fixed-end strap assembly.
- 6.2.5.13 A 3-point chest/lap belt with height adjuster shall be made available for fastening passenger in place for each wheelchair position. The belt shall be two inches (2") wide, seventy inches (70") long, with a strength rating of not less than two thousand five hundred (2,500) pounds. One end of this belt shall be secured to a female seat belt fitting and the other end shall have a male seat belt fitting. The belt assembly shall be adjustable for length. The seat belt assembly shall have a quick-release and a snap lock to connect both ends together. This belt is used to secure the wheelchair passenger to the wheelchair.



- 6.2.5.14 A wall mounted shoulder harness system shall be provided at each wheelchair securement location that is compatible with the specified restraints. The harness system shall be installed in accordance with all structural requirements established by the restraint supplier and all applicable regulations, including 49 CFR Part 571.
- 6.2.5.15 Provisions shall be made to store all the previously described belts, straps, pads and harness assemblies in a secure and convenient location.
- 6.2.5.16 The floor shall be corrosion resistant coated metal, joined to the body frame members in a manner to provide a leak proof floor. The vehicle shall be fully undercoated with a non-flammable resin-type material such as polyoleum.
- 6.2.5.17 Transit-grade flooring shall be provided on the interior surface.
- 6.2.5.18 Without passengers or driver and with all available options installed, there must be a minimum of 12.7 cm (5") of clearance between the breakover angle position of the vehicle exhaust pipe or the lowest point on the undercarriage and level ground.

6.2.6 Emergency Exit:

- 6.2.6.1 If the vehicle is equipped with a driver's side passenger door, this may serve as the emergency exit. This door shall be equipped with an interior manual release and an interior sign or decal shall be posted on the door stating "Emergency Exit Only".
- 6.2.6.2 If the vehicle is not equipped with a driver's side passenger door, the rear hatch shall serve as the emergency exit. An interior sign or decal shall be posted on the hatch stating "Emergency Exit Only" and shall be equipped with an interior manual release. The rear bench seat shall fold down allowing for exit in the event of a rollover accident.

6.2.7 Special State Law Provisions:

The vehicle shall be equipped with two or more hazard lamps that:

- 6.2.7.1 Are mounted at the same level on the rear of the vehicle.
- 6.2.7.2 Are visible at a distance of 500 feet in normal sunlight.
- 6.2.7.3 Flash.
- 6.2.7.4 Emit amber light.
- 6.2.7.5 The vehicle shall bear a sign on the rear of the vehicle stating: "Caution--children may be exiting".

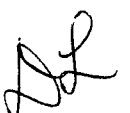

6.2.8 Safety Equipment:

- 6.2.8.1 A first aid kit meeting OSHA 5/15 standards shall be provided and conveniently stored or mounted.
- 6.2.8.2 A minimum of two and a half pound (2.5 lbs.) fire extinguisher shall be provided and stored or mounted near the driver's area.
- 6.2.8.3 A three-piece triangle warning reflector kit shall be secured in the vehicle.
- 6.2.8.4 Back-up alarm that is electrically operated and produces an intermittent sound when the vehicle is shifted into reverse shall be furnished to warn others while vehicle movement is in reverse. The alarm shall meet or exceed SAE J994B standards.
- 6.2.8.5 Safety plaques or decals shall be furnished and affixed at any hazardous area. The safety plaques or decals shall describe the nature of the hazard, level of hazard seriousness, how to avoid the hazard, and the consequence of human interaction with the hazard. Permanent plaques are preferred to decals. Type, size and location of product safety plaques or decals shall be in accordance with ANSI 535 4-1991, or latest revision thereto.

7.0 FEDERAL CLAUSES:

- 7.1 **No Government Obligation to Third Parties.** Fort Bend County and the Contractor acknowledge and agree that, notwithstanding any concurrence by the Federal Government in or approval of the solicitation or award of the underlying contract, absent the express written consent by the Federal Government, the Federal Government is not a party to this contract and shall not be subject to any obligations or liabilities to Fort Bend County, the Contractor, or any other party (whether or not a party to that contract) pertaining to any matter resulting from the underlying contract. The Contractor agrees to include this clause in each subcontract financed in whole or in part with Federal assistance provided by FTA. It is further agreed that the clause shall not be modified, except to identify the subcontractor who will be subject to its provisions.
- 7.2 **Program Fraud and False or Fraudulent Statement and Related Acts.** The Contractor acknowledges that the provisions of the Program Fraud Civil Remedies Act of 1986, as amended, 31 U.S.C. § 3801 et seq. and U.S. DOT regulations, "Program Fraud Civil Remedies," 49 C.F.R. Part 31, apply to its actions pertaining to this Project. Upon execution of the underlying contract, the Contractor certifies or affirms the truthfulness and accuracy of any statement it has made, it makes, it may make, or causes to be made, pertaining to the underlying contract or the FTA assisted project for which this contract work is being performed. In addition to other penalties that may be applicable, the

Contractor further acknowledges that if it makes, or causes to be made, a false, fictitious, or fraudulent claim, statement, submission, or certification, the Federal Government reserves the right to impose the penalties of the Program Fraud Civil Remedies Act of 1986 on the Contractor to the extent the Federal Government deems appropriate.

The Contractor also acknowledges that if it makes, or causes to be made, a false, fictitious, or fraudulent claim, statement, submission, or certification to the Federal Government under a contract connected with a project that is financed in whole or in part with Federal assistance originally awarded by FTA under the authority of 49 U.S.C. § 5307, the Government reserves the right to impose the penalties of 18 U.S.C. § 1001 and 49 U.S.C. § 5307(n)(1) on the Contractor, to the extent the Federal Government deems appropriate.

The Contractor agrees to include the above two clauses in each subcontract financed in whole or in part with Federal assistance provided by FTA. It is further agreed that the clauses shall not be modified, except to identify the subcontractor who will be subject to the provisions.

- 7.3 **Access to Records and Reports.** The Contractor agrees to provide Fort Bend County, the FTA Administrator, the Comptroller General of the United States or any of their authorized representatives access to any books, documents, papers and records of the Contractor which are directly pertinent to this contract for the purposes of making audits, examinations, excerpts and transcriptions. Contractor also agrees, pursuant to 49 C.F.R. 633.17 to provide the FTA Administrator or his authorized representatives including any PMO Contractor access to Contractor's records and construction sites pertaining to a major capital project, defined at 49 U.S.C. 5302(a)1, which is receiving federal financial assistance through the programs described at 49 U.S.C. 5307, 5309 or 5311. The Contractor agrees to permit any of the foregoing parties to reproduce by any means whatsoever or to copy excerpts and transcriptions as reasonably needed.

The Contractor agrees to maintain all books, records, accounts and reports required under this contract for a period of not less than three years after the date of termination or expiration of this contract, except in the event of litigation or settlement of claims arising from the performance of this contract, in which case Contractor agrees to maintain same until Fort Bend County, the FTA Administrator, the Comptroller General, or any of their duly authorized representatives, have disposed of all such litigation, appeals, claims or exceptions related thereto.

- 7.4 **Federal Changes.** The Contractor shall at all times comply with all applicable FTA regulations, policies, procedures and directives, including without limitation those listed directly or by reference in the Master Agreement between Fort Bend County and FTA, as they may be amended or promulgated from time to time during the term of this contract. Contractor's failure to so comply shall constitute

Handwritten signature or initials in the bottom right corner of the page.

a material breach of this contract.

**7.5 Civil Rights Requirements.** The following requirements apply to the underlying contract:

Nondiscrimination - In accordance with Title VI of the Civil Rights Act, as amended, 42 U.S.C. § 2000d, section 303 of the Age Discrimination Act of 1975, as amended, 42 U.S.C. § 6102, section 202 of the Americans with Disabilities Act of 1990, 42 U.S.C. § 12132, and Federal transit law at 49 U.S.C. § 5332, the Contractor agrees that it will not discriminate against any employee or applicant for employment because of race, color, creed, national origin, sex, age, or disability. In addition, the Contractor agrees to comply with applicable Federal implementing regulations and other implementing requirements FTA may issue.

Equal Employment Opportunity - The following equal employment opportunity requirements apply to the underlying contract:

Race, Color, Creed, National Origin, Sex - In accordance with Title VII of the Civil Rights Act, as amended, 42 U.S.C. § 2000e, and Federal transit laws at 49 U.S.C. § 5332, the Contractor agrees to comply with all applicable equal employment opportunity requirements of U.S. Department of Labor (U.S. DOL) regulations, "Office of Federal Contract Compliance Programs, Equal Employment Opportunity, Department of Labor," 41 C.F.R. Parts 60 et seq., (which implement Executive Order No. 11246, "Equal Employment Opportunity," as amended by Executive Order No. 11375, "Amending Executive Order 11246 Relating to Equal Employment Opportunity," 42 U.S.C. § 2000e note), and with any applicable Federal statutes, executive orders, regulations, and Federal policies that may in the future affect construction activities undertaken in the course of the Project. The Contractor agrees to take affirmative action to ensure that applicants are employed, and that employees are treated during employment, without regard to their race, color, creed, national origin, sex, or age. Such action shall include, but not be limited to, the following: employment, upgrading, demotion or transfer, recruitment or recruitment advertising, layoff or termination; rates of pay or other forms of compensation; and selection for training, including apprenticeship. In addition, the Contractor agrees to comply with any implementing requirements FTA may issue.

Age - In accordance with section 4 of the Age Discrimination in Employment Act of 1967, as amended, 29 U.S.C. § § 623 and Federal transit law at 49 U.S.C. § 5332, the Contractor agrees to refrain from discrimination against present and prospective employees for reason of age. In addition, the Contractor agrees to comply with any implementing requirements FTA may issue.

Disabilities - In accordance with section 102 of the Americans with Disabilities Act, as amended, 42 U.S.C. § 12112, the Contractor agrees that it will comply with the requirements of U.S. Equal Employment Opportunity Commission,



"Regulations to Implement the Equal Employment Provisions of the Americans with Disabilities Act," 29 C.F.R. Part 1630, pertaining to employment of persons with disabilities. In addition, the Contractor agrees to comply with any implementing requirements FTA may issue.

The Contractor also agrees to include these requirements in each subcontract financed in whole or in part with Federal assistance provided by FTA, modified only if necessary to identify the affected parties.

- 7.6 **Disadvantaged Business Enterprise (DBE).** This contract is subject to the requirements of Title 49, Code of Federal Regulations, Part 26, *Participation by Disadvantaged Business Enterprises in Department of Transportation Financial Assistance Programs*.

The Contractor shall not discriminate on the basis of race, color, national origin, or sex in the performance of this contract. The contractor shall carry out applicable requirements of 49 CFR Part 26 in the award and administration of this DOT-assisted contract. Failure by the Contractor to carry out these requirements is a material breach of this contract, which may result in the termination of this contract or such other remedy as Fort Bend County deems appropriate. Each subcontract the Contractor signs with a subcontractor must include the assurance in this paragraph (*see* 49 CFR 26.13(b)).

The successful bidder/offeror will be required to report its DBE participation obtained through race-neutral means throughout the period of performance.

The Contractor is required to pay its subcontractors performing work related to this Contract for satisfactory performance of that work no later than 30 days after the Contractor's receipt of payment for that work from Fort Bend County. In addition, the Contractor is required to return any retainage payments to those subcontractors within 30 days after the subcontractor's work related to this Contract is satisfactorily completed.

The Contractor must promptly notify Fort Bend County whenever a DBE subcontractor performing work related to this Contract is terminated or fails to complete its work, and must make good faith efforts to engage another DBE subcontractor to perform at least the same amount of work. The Contractor may not terminate any DBE subcontractor and perform that work through its own forces or those of an affiliate without the prior written consent of Fort Bend County.

- 7.7 **Incorporation of Federal Transit Administration (FTA) Terms.** The preceding provisions include, in part, certain Standard Terms and Conditions required by DOT, whether or not expressly set forth in the preceding contract provisions. All contractual provisions required by DOT, as set forth in FTA Circular 4220.1E, are hereby incorporated by reference. Anything to the contrary



herein notwithstanding, all FTA mandated terms shall be deemed to control in the event of a conflict with other provisions contained in this Agreement. The Contractor shall not perform any act, fail to perform any act, or refuse to comply with any Fort Bend County requests which would cause Fort Bend County to be in violation of the FTA terms and conditions.

- 7.8 **Government-Wide Debarment and Suspension (Non-Procurement).** This contract is a covered transaction for purposes of 49 CFR Part 29. As such, the Contractor is required to verify that none of the Contractor, its principals, as defined at 49 CFR 29.995, or affiliates, as defined at 49 CFR 29.905, are excluded or disqualified as defined at 49 CFR 29.940 and 29.945.

The Contractor is required to comply with 49 CFR 29, Subpart C and must include the requirement to comply with 49 CFR 29, Subpart C in any lower tier covered transaction it enters into.

By signing and submitting its bid or proposal, the bidder or proposer certifies as follows:

The certification in this clause is a material representation of fact relied upon by Fort Bend County. If it is later determined that the bidder or proposer knowingly rendered an erroneous certification, in addition to remedies available to Fort Bend County, the Federal Government may pursue available remedies, including but not limited to suspension and/or debarment. The bidder or proposer agrees to comply with the requirements of 49 CFR 29, Subpart C while this offer is valid and throughout the period of any contract that may arise from this offer. The bidder or proposer further agrees to include a provision requiring such compliance in its lower tier covered transactions.

- 7.9 **Buy America.** The Contractor agrees to comply with 49 U.S.C. 5323(j) and 49 C.F.R. Part 661, which provide that Federal funds may not be obligated unless steel, iron, and manufactured products used in FTA-funded projects are produced in the United States, unless a waiver has been granted by FTA or the product is subject to a general waiver. General waivers are listed in 49 C.F.R. 661.7, and include final assembly in the United States for 15 passenger vans and 15 passenger wagons produced by Chrysler Corporation, and microcomputer equipment and software. Separate requirements for rolling stock are set out at 49 U.S.C. 5323(j)(2)(C) and 49 C.F.R. 661.11. Rolling stock must be assembled in the United States and have a 60 percent domestic content.

A bidder or offeror must submit to the FTA recipient the appropriate Buy America certification with all bids or offers on FTA-funded contracts, except those subject to a general waiver. Bids or offers that are not accompanied by a completed Buy America certification must be rejected as nonresponsive. This requirement does not apply to lower tier subcontractors.

- 7.10 **Lobbying.** Contractors who apply or bid for an award of \$100,000 or more shall file the certification required by 49 CFR part 20, "New Restrictions on Lobbying." Each tier certifies to the tier above that it will not and has not used Federal appropriated funds to pay any person or organization for influencing or attempting to influence an officer or employee of any agency, a member of Congress, officer or employee of Congress, or an employee of a member of Congress in connection with obtaining any Federal contract, grant or any other award covered by 31 U.S.C. 1352. Each tier shall also disclose the name of any registrant under the Lobbying Disclosure Act of 1995 who has made lobbying contacts on its behalf with non-Federal funds with respect to that Federal contract, grant or award covered by 31 U.S.C. 1352. Such disclosures are forwarded from tier to tier up to the recipient.
- 7.11 **Clean Air.** The Contractor agrees to comply with all applicable standards, orders or regulations issued pursuant to the Clean Air Act, as amended, 42 U.S.C. §§ 7401 et seq . The Contractor agrees to report each violation to the Purchaser and understands and agrees that the Purchaser will, in turn, report each violation as required to assure notification to FTA and the appropriate EPA Regional Office. The Contractor also agrees to include these requirements in each subcontract exceeding \$100,000 financed in whole or in part with Federal assistance provided by FTA.
- 7.12 **Clean Water.** The Contractor agrees to comply with all applicable standards, orders or regulations issued pursuant to the Federal Water Pollution Control Act, as amended, 33 U.S.C. 1251 et seq . The Contractor agrees to report each violation to the Purchaser and understands and agrees that the Purchaser will, in turn, report each violation as required to assure notification to FTA and the appropriate EPA Regional Office. The Contractor also agrees to include these requirements in each subcontract exceeding \$100,000 financed in whole or in part with Federal assistance provided by FTA.
- 7.13 **Cargo Preference.** The Contractor agrees:
- (1) to use privately owned United States-Flag commercial vessels to ship at least 50 percent of the gross tonnage (computed separately for dry bulk carriers, dry cargo liners, and tankers) involved, whenever shipping any equipment, material, or commodities pursuant to the underlying contract to the extent such vessels are available at fair and reasonable rates for United States-Flag commercial vessels;
  - (2) to furnish within 20 working days following the date of loading for shipments originating within the United States or within 30 working days following the date of leading for shipments originating outside the United States, a legible copy of a rated, "on-board" commercial ocean bill-of -lading in English for each shipment of cargo described in the preceding paragraph to the Division of National Cargo, Office of Market Development, Maritime Administration, Washington, DC 20590



and to the FTA recipient (through the contractor in the case of a subcontractor's bill-of-lading.)

(3) to include these requirements in all subcontracts issued pursuant to this contract when the subcontract may involve the transport of equipment, material, or commodities by ocean vessel.

**7.14 Fly America.** The Contractor agrees to comply with 49 U.S.C. 40118 (the "Fly America" Act) in accordance with the General Services Administration's regulations at 41 CFR Part 301-10, which provide that recipients and subrecipients of Federal funds and their contractors are required to use U.S. Flag air carriers for U.S. Government-financed international air travel and transportation of their personal effects or property, to the extent such service is available, unless travel by foreign air carrier is a matter of necessity, as defined by the Fly America Act. The Contractor shall submit, if a foreign air carrier was used, an appropriate certification or memorandum adequately explaining why service by a U.S. flag air carrier was not available or why it was necessary to use a foreign air carrier and shall, in any event, provide a certificate of compliance with the Fly America requirements. The Contractor agrees to include the requirements of this section in all subcontracts that may involve international air transportation.

**7.15 Contract Work Hours and Safety Standards.**

(1) Overtime requirements - No contractor or subcontractor contracting for any part of the contract work which may require or involve the employment of laborers or mechanics shall require or permit any such laborer or mechanic in any workweek in which he or she is employed on such work to work in excess of forty hours in such workweek unless such laborer or mechanic receives compensation at a rate not less than one and one-half times the basic rate of pay for all hours worked in excess of forty hours in such workweek.

(2) Violation; liability for unpaid wages; liquidated damages - In the event of any violation of the clause set forth in paragraph (1) of this section the Contractor and any subcontractor responsible therefore shall be liable for the unpaid wages. In addition, such Contractor and subcontractor shall be liable to the United States for liquidated damages. Such liquidated damages shall be computed with respect to each individual laborer or mechanic, including watchmen and guards, employed in violation of the clause set forth in paragraph (1) of this section, in the sum of \$10 for each calendar day on which such individual was required or permitted to work in excess of the standard workweek of forty hours without payment of the overtime wages required by the clause set forth in paragraph (1) of this section.

(3) Withholding for unpaid wages and liquidated damages – Fort Bend County shall upon its own action or upon written request of an authorized representative of the Department of Labor withhold or cause to be withheld, from any moneys payable on account of work performed by the Contractor or subcontractor under any such contract or any other Federal contract with the same prime contractor, or



any other federally-assisted contract subject to the Contract Work Hours and Safety Standards Act, which is held by the same prime contractor, such sums as may be determined to be necessary to satisfy any liabilities of such contractor or subcontractor for unpaid wages and liquidated damages as provided in the clause set forth in paragraph (2) of this section.

(4) Subcontracts - The Contractor or subcontractor shall insert in any subcontracts the clauses set forth in paragraphs (1) through (4) of this section and also a clause requiring the subcontractors to include these clauses in any lower tier subcontracts. The prime contractor shall be responsible for compliance by any subcontractor or lower tier subcontractor with the clauses set forth in paragraphs (1) through (4) of this section.

**7.16 Energy Conservation Requirements.** The Contractor agrees to comply with mandatory standards and policies relating to energy efficiency which are contained in the state energy conservation plan issued in compliance with the Energy Policy and Conservation Act.

**7.17 Access for Individuals with Disabilities.** The Contractor agrees to comply with 49 U.S.C. § 5301(d), which states the Federal policy that elderly individuals and individuals with disabilities have the same right as other individuals to use public transportation services and facilities, and that special efforts shall be made in planning and designing those services and facilities to implement transportation accessibility rights for elderly individuals and individuals with disabilities. The Contractor also agrees to comply with all applicable provisions of section 504 of the Rehabilitation Act of 1973, as amended, with 29 U.S.C. § 794, which prohibits discrimination on the basis of disability; with the Americans with Disabilities Act of 1990 (ADA), as amended, 42 U.S.C. §§ 12101 *et seq.*, which requires that accessible facilities and services be made available to individuals with disabilities; and with the Architectural Barriers Act of 1968, as amended, 42 U.S.C. §§ 4151 *et seq.*, which requires that buildings and public accommodations be accessible to individuals with disabilities, and any subsequent amendments to these laws. In addition, the Contractor agrees to comply with applicable implementing Federal regulations and directives and any subsequent amendments thereto, as follows:

- (1) U.S. DOT regulations, "Transportation Services for Individuals with Disabilities (ADA)," 49 C.F.R. Part 37;
- (2) U.S. DOT regulations, "Nondiscrimination on the Basis of Handicap in Programs and Activities Receiving or Benefiting from Federal Financial Assistance," 49 C.F.R. Part 27;
- (3) Joint U.S. Architectural and Transportation Barriers Compliance Board (U.S. ATBCB)/U.S. DOT regulations, "Americans With Disabilities (ADA) Accessibility Specifications for Transportation Vehicles," 36 C.F.R. Part 1192 and 49 C.F.R. Part 38;
  - a. U.S. DOJ regulations, "Nondiscrimination on the Basis of Disability in State and Local Government Services," 28 C.F.R. Part 35;



- b. U.S. DOJ regulations, "Nondiscrimination on the Basis of Disability by Public Accommodations and in Commercial Facilities," 28 C.F.R. Part 36;
- c. U.S. General Services Administration (U.S. GSA) regulations, "Accommodations for the Physically Handicapped," 41 C.F.R. Subpart 101-19;
- d. U.S. EEOC, "Regulations to Implement the Equal Employment Provisions of the Americans with Disabilities Act," 29 C.F.R. Part 1630;
- e. U.S. Federal Communications Commission regulations, "Telecommunications Relay Services and Related Customer Premises Equipment for the Hearing and Speech Disabled," 47 C.F.R. Part 64, Subpart F; and
- f. U.S. ATBCB regulations, "Electronic and Information Technology Accessibility Standards," 36 C.F.R. Part 1194;
- g. FTA regulations, "Transportation for Elderly and Handicapped Persons," 49 C.F.R. Part 609; and
- h. Federal civil rights and nondiscrimination directives implementing the foregoing regulations, except to the extent the Federal Government determines otherwise in writing.

**8.0 UNIT BID PRICE:**

**Unit bid price, for one (1) new wheelchair accessible minivan without optional equipment, as specified herein, F.O.B. point of delivery in Fort Bend County, Texas:**

\$ 38,476 /each

**9.0 OPTIONAL EQUIPMENT:**

Pricing as an option shall be provided for installation of a fare box. The option price will include a fare box to be mounted with trip handle toward driver. It shall be mounted on a stanchion, adequately braced, located near the driver and easily accessible to passengers entering the vehicle. An amber or indirect fare box light shall be connected to the dash instrument lights. Two interchangeable, lockable fare box vaults and fare box, keyed alike, with a double set of keys for each lock shall be supplied. Vault and fare box exteriors shall be marked with key reference. Vehicle shall be provided with wiring and structural support to install the fare box. Wiring for fare box circuit shall be two (2) No. 14 insulated wires in vinyl tubing, one energized directly from a battery positive feed protective circuit breaker and the other to ground. Example: Main Fare Box model Treasury 1, Diamond (or approved equal).

\$ 1,375 /each

**10.0 POINT OF CONTACT:**



Point of contact will be Debbie Kaminski, CPPB, Assistant County Purchasing Agent at (281) 341-8643 or kaminskd@co.fort-bend.tx.us.

**11.0 ENCLOSED FORMS:**

- 11.1 W9
- 11.2 Certification Forms
- 11.3 Consolidated Certification Forms
- 11.4 TVM Certification

A handwritten signature in black ink, appearing to be the initials 'DK' or similar, located in the bottom right corner of the page.

CONTRACT SHEET  
Bid 12-052

THE STATE OF TEXAS  
COUNTY OF FORT BEND

This memorandum of agreement made and entered into on the 5 day of June, 2012, by and between Fort Bend County in the State of Texas (hereinafter designated County), acting herein by County Judge Robert Hebert, by virtue of an order of Fort Bend County Commissioners Court, and TEXAS BUS SALES, INC.  
(Company name)  
(hereinafter designated Contractor).

WITNESSETH:

The Contractor and the County agree that the bid and specifications for the **Minivan** which are hereto attached and made a part hereof, together with this instrument and the bond (when required) shall constitute the full agreement and contract between parties and for furnishing the items set out and described; the County agrees to pay the prices stipulated in the accepted bid.

It is further agreed that this contract shall not become binding or effective until signed by the parties hereto and a purchase order authorizing the items desired has been issued.

Executed at Richmond, Texas this 5 day of June, 2012.

By: Robert Hebert Fort Bend County, Texas  
County Judge

By: Dianne Ledet  
Signature of Contractor

By: DIANNE LEDET, GENERAL MANAGER  
Printed Name and Title

# CERTIFICATION FORMS

**Please fill out and sign the following forms and return with your Bid Proposal.**

A handwritten signature in black ink, appearing to be the initials 'DF', located in the bottom right corner of the page.

## CERTIFICATION FORM

In submitting this proposal, the undersigned certifies on behalf of its firm and any proposed subcontractors as follows:

- (1) **Bid Validity Certification:** If this offer is accepted within one hundred twenty (120) calendar days from the due date, to furnish any or all services upon which prices are offered at the designated point within the time specified;
- (2) **Non-Collusion Certification:** Has made this proposal independently, without consultation, communication, or agreement for the purpose of restricting competition as to any matter relating to this proposal with any other FIRM or with any other competitor,
- (3) **Affirmative Action/DBE:** Is in compliance with the Common Grant Rules affirmative action and Department of Transportation's Disadvantaged Business Enterprise requirements.
- (4) **Non-Conflict Certification:** Represents and warrants that no employee, official, or member of the Fort Bend County Commissioners Court is or will be pecuniarily benefited directly or indirectly in this Contract,
- (5) **Non-Inducement Certification:** The undersigned hereby certifies that neither it nor any of its employees, representatives, or agents have offered or given gratuities (in the form of entertainment, gifts, or otherwise) to any director, officer, or employee of Fort Bend County with the view toward securing favorable treatment in the awarding, amending, or the making of any determination with respect to the performance of this Contract.
- (6) **Debarment and Suspension:** The undersigned is neither debarred nor suspended from Federal programs under U. S. Department of Transportation regulations, "Nonprocurement Suspension and Debarment," 2 CFR Parts 180 and 1200, or under the FAR at 48 CFR Chapter 1, Part 9.4.
- (7) **Integrity and Ethics:** Has a satisfactory record of integrity and business ethics, in compliance with 49 U.S.C. Section 5325(j)(2)(A)
- (8) **Public Policy:** Is in compliance with the public policies of the Federal Government, as required by 49 U.S.C. Section 5325(j)(2)(B)
- (9) **Administrative and Technical Capacity:** Has the necessary organization, experience, accounting, and operational controls, and technical skills, or the ability to obtain them, in compliance with 49 U.S.C. Section 5325(j)(2)(D)
- (10) **Licensing and Taxes:** Is in compliance with applicable licensing and tax laws and regulations
- (11) **Financial Resources:** Has, or can obtain, sufficient financial resources to perform the contract, as required by 49 U. S. C. Section 5325 (j)(2)(D)
- (12) **Production Capability:** Has, or can obtain, the necessary production, construction, and technical equipment and facilities.
- (13) **Timeliness:** Is able to comply with the required delivery or performance schedule, taking into consideration all existing commercial and governmental business commitments.
- (14) **Performance Record:** Is able to provide a satisfactory current and past performance record.

  
Signature

TEXAS BUS SALES, INC.  
Firm Name

DIANNE LEDET, GENERAL MANAGER  
Printed Name/Title

05-17-12  
Date







4. State the names of each employee or officer of a "consultant" for Fort Bend County who worked on any matter related to the subject of this contract and has an "ownership interest" constituting 3% or more of the ownership in the above named "firm"

NAME

CONSULTANT NONE

---

**CERTIFICATE**

I certify that all information provided is true and correct as of the date of this statement, that I have not knowingly withheld disclosure of any information requested; and that supplemental statements will be promptly submitted to Fort Bend County as changes occur.

**Certifying Person:** DIANNE LEDET

**Title:** GENERAL MANAGER

(Type or Print)

Signature of Certifying Person: *Dianne Ledet*

Date: 05-17-12

*DL*

**Buy America Certificate**

**Certification required for procurement of steel, iron, or manufactured products (required for contracts over \$100,000).**

Certificate of Compliance with 49 C.F.R. 661

**The bidder or offeror hereby certifies that it will meet the requirements of Section 165(a) of the Surface Transportation Assistance Act of 1982 and the regulations of 49 C.F.R. 661.**

Date 05-17-12

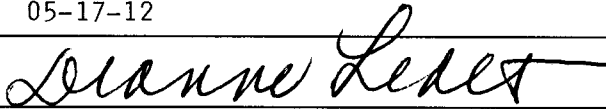
Signature 

Printed Name: DIANNE LEDET

Title GENERAL MANAGER

Company Name TEXAS BUS SALES, INC.

or

Certificate of Non-Compliance with 49 C.F.R. 661

**The bidder or offeror hereby certifies that it cannot comply with the requirements of Section 165(a) of the Surface Transportation Assistance Act of 1982 and the regulations of 49 C.F.R. 661.7.**

Date \_\_\_\_\_

Signature \_\_\_\_\_

Printed Name: \_\_\_\_\_

Title \_\_\_\_\_

Company Name \_\_\_\_\_



**CERTIFICATION  
OF  
RESTRICTIONS ON LOBBYING**  
(Required for contracts over \$100,000.)

I, DIANNE LEDET, GENERAL MANAGER, hereby certify on behalf of  
(Name) (Title)  
the TEXAS BUS SALES, INC., that:  
(Company Name)

- (1) No federal appropriated funds have been paid or will be paid, by or on behalf of the undersigned, to any person for influencing or attempting to influence an officer or employee of any Federal agency, a Member of Congress, an officer or employee of Congress, or an employee of a Member of Congress, regarding the award of Federal assistance, or the extension, continuation, renewal, amendment, or modification of any Federal assistance agreement, contract, grant, loan, or cooperative agreement.
- (2) If any funds other than Federal appropriated funds have been paid or will be paid to any person for influencing or attempting to influence an officer or employee of any Federal agency, a Member of Congress, an officer or employee of Congress, or an employee of a Member of Congress in connection with any application for Federal assistance, federal contract, grant, loan, or cooperative agreement, the undersigned shall complete and submit Standard Form-LLL: "Disclosure of Form to Report Lobbying," including information required by the instructions accompanying the form, which form may be amended to omit such information as authorized by 49 CFR Part 20.110.
- (3) The undersigned shall require that the language of this certification be included in the award documents for all subawards at all tiers (including subcontracts, subgrants, and contracts under grants, loans, and cooperative agreements) and that all subrecipients shall certify and disclose accordingly.

The undersigned understands that this certification is a material representation of fact upon which reliance is placed and that submission of this certification is a prerequisite for providing Federal assistance for a transaction covered by 49 CFR Part 20.110. Any person who fails to file the required certification shall be subject to a civil penalty of not less than \$10,000 and not more than \$100,000 for each such failure.

Executed this 17 day of MAY, 2012.

Signed:

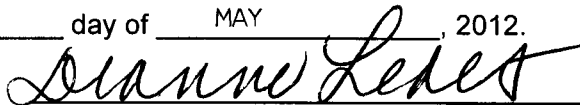

Printed Name:

DIANNE LEDET

Company Name:

TEXAS BUS SALES, INC.



**TRANSIT VEHICLE MANUFACTURERS (TVM)**  
**CERTIFICATE OF COMPLIANCE**  
**WITH DISADVANTAGED BUSINESS REGULATIONS**

This procurement is subject to the provisions of 49 CFR Section 26.49. Accordingly, the following certification must be completed and submitted with the proposal as a condition of proposing. A proposal that does not include this certification will not be considered.

**TVM Certification**

The bidder, if a transit vehicle manufacturer, hereby certifies that it has complied with the requirements of 49 CFR Section 26.49 by submitting a current annual DBE goal to the Federal Transit Administration. The goals apply to Federal Fiscal Year 2012 (Oct. 1, 2011 through Sept. 30, 2012) and have either been approved or not by FTA.

The bidder, if a non-vehicle manufacturer supplier, hereby certifies that the manufacturer of the transit vehicle to be supplied has complied with the above-referenced requirements of 49 CFR Section 26.49.

Manufacturer: ELDORADO NATIONAL

Manufacturer Representative Signature: 

Dealer: TEXAS BUS SALES, INC.

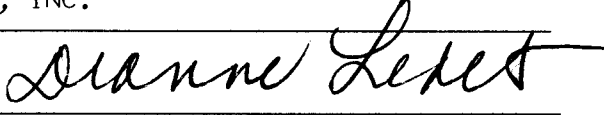
Dealer Representative Signature: 

Date: 05-17-12

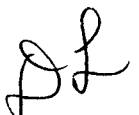



## Consolidated Certification Form

### I. FOR ALL BIDS:

The undersigned vendor certifies to abide by these clauses and include the following clauses in each subcontract financed in whole or in part with Federal Transit Administration (FTA) funds. Vendors are certifying by reference the entire list of FTA FY 2011 Certifications and Assurances, and shall download the same at:  
<http://www.gpo.gov/fdsys/pkg/FR-2010-11-02/pdf/2010-27563.pdf>.

#### A. Disadvantaged Business Enterprises (DBE) Certification

The vendor will provide products compliant with 49 CFR 26.49 regarding the vehicle manufacturer's overall DBE goal.

#### B. Access to Third Party Contract Records

As required by 49 U.S.C. § 5325(g). The VENDOR agrees provide sufficient access to records as needed to assure proper project management and compliance with Federal laws and regulations.

#### C. Interest of Members of or Delegates to Congress

The vendor certifies that no member of or delegate to the Congress of the United States (US) shall be admitted to any share or part of this contract or to any benefit arising therefrom.

#### D. Prohibited Interest

The vendor certifies that no member, officer or employee of the Public Body or of a local public body during his or her tenure or one year thereafter shall have any interest, direct or indirect, in this contract or the proceeds thereof.

#### E. Cargo Preference - Use of United States-Flag Vessels

The vendor agrees: a. to use privately owned US -Flag commercial vessels to ship at least 50 percent of the gross tonnage (computed separately for dry bulk carriers, dry cargo liners, and tankers) involved, whenever shipping any equipment, material or commodities pursuant to the underlying contract to the extent such vessels are available at fair and reasonable rates for US-Flag commercial vessels; b. to furnish within 20 working days following the date of loading for shipments originating within the US or within 30 working days following the date of loading for shipments originating outside the US, a legible copy of a rated, "on-board" commercial ocean bill-of-lading in English for each shipment of cargo to the Division of National Cargo, Office of Market Development, Maritime Administration, Washington, DC 20590 and to the FTA recipient (through the contractor in the case of a subcontractor's bill-of-lading).

#### F. Energy Conservation

The vendor agrees to comply with mandatory standards and policies relating to energy efficiency, which are contained in the state energy conservation plan issued in compliance with the Energy Policy and Conservation Act.

#### G. No Obligation by the Federal Government.

The Purchaser and vendor acknowledge and agree that, notwithstanding any concurrence by the Federal Government in or approval of the solicitation or award of the underlying contract, absent the express written consent by the Federal Government, the Federal Government is not a party to this contract and shall not be subject to any obligations or liabilities to the Purchaser, Contractor or any other party (whether or not a party to that contract) pertaining to any matter resulting from the underlying contract).

#### H. Program Fraud and False or Fraudulent Statements or Related Acts

The vendor acknowledges that the provisions of the Program Fraud Civil Remedies Act of 1986, as amended, 31 U.S.C. §3801 et seq. and U.S. DOT regulations, "Program Fraud Civil Remedies," 49 C.F.R. Part 31, apply to its actions pertaining to this project. The vendor certifies truthfulness and accuracy of any statement it makes pertaining to the FTA-assisted project. The vendor acknowledges that if it makes, or causes to be made, a false, fictitious or fraudulent claim, statement, submission or certification, the Federal Government reserves the right to impose the penalties of the Program Fraud Civil Remedies Act of 1986 as deemed appropriate. The vendor acknowledges that if it makes, or causes to be made, a false, fictitious or fraudulent claim, statement submission, or certification to the Federal Government relating to the FTA-assisted project, per 49 U.S.C. §5307, the Government reserves the right to impose the penalties of 18 U.S.C. §1001 and 49 U.S.C. §5307(n)(1) on the Contractor, as deemed appropriate.

I. Contract Work Hours

(1) **Overtime requirements** - No contractor or subcontractor contracting for any part of the contract work which may require or involve the employment of laborers or mechanics shall require or permit any such laborer or mechanic in any workweek in which he or she is employed on such work to work in excess of forty hours in such workweek unless such laborer or mechanic receives compensation at a rate not less than one and one-half times the basic rate of pay for all hours worked in excess of forty hours in such workweek.

(2) **Violation; liability for unpaid wages; liquidated damages** - In the event of any violation of the clause set forth in paragraph (1) of this section, the contractor & any subcontractor responsible therefore shall be liable for unpaid wages and shall be liable to the United States for liquidated damages which shall be computed for each individual laborer, mechanic, watchman or guard employed in violation of the clause set forth in paragraph (1) of this section, in the sum of \$10 for each calendar day that an individual was required / permitted to work over 40 hours in a workweek without payment of overtime wages required by the clause in paragraph (1) of this section.

(3) **Withholding for unpaid wages and liquidated damages** - The purchaser shall upon its own action or upon written request of the Department of Labor (DOL) withhold or cause to be withheld, from any money payable for work performed by the contractor or subcontractor under any contract or other Federal contract with the same prime contractor, or any other federally-assisted contract subject to the Contract Work Hours and Safety Standards Act, which is held by the same prime contractor, such sums to satisfy any liabilities of such contractor or subcontractor for unpaid wages and liquidated damages as set-forth in paragraph (2) of this section.

(4) **Subcontracts** - The contractor or subcontractor shall include the clauses set forth in this section and require the same from subcontractors to include these clauses in any lower tier subcontracts. The prime contractor shall be responsible for compliance by any subcontractor or lower tier subcontractor with these clauses.

(5) **Payrolls and basic records** - Payrolls and related basic records shall be maintained by the contractor during the course of the work and preserved for three years thereafter for all laborers and mechanics working at the work site (or under the United States Housing Act of 1937 or the Housing Act of 1949, in the construction or development of the project). Such records shall contain the name, address and social security number of each worker, his or her correct classification, hourly rates of wages paid (including rates of contributions or costs anticipated for bona fide fringe benefits or cash equivalents thereof of the types described in section 1(b)(2)(B) of the Davis-Bacon Act), daily and weekly number of hours worked, deductions made and actual wages paid. Whenever the Secretary of Labor has found under 29 CFR 5.5(a)(1)(iv) that the wages of any laborer or mechanic include the amount of any costs reasonably anticipated in providing benefits under a plan or program described in section 1(b)(2)(B) of the Davis-Bacon Act, the contractor shall maintain records showing that the commitment to provide such benefits is enforceable, that the plan or program is financially responsible, that the plan or program has been communicated in writing to the laborers or mechanics affected, and records of the costs anticipated or actual costs incurred in providing such benefits. Contractors employing apprentices or trainees under approved programs shall maintain written evidence of registration of apprenticeship programs, certification of trainee programs, registration of the apprentices and trainees, and ratios & wage rates prescribed in applicable programs.

J. Civil Rights

(1) **Nondiscrimination** - In accordance with Title VI of the Civil Rights Act (CRA), as amended, 42 U.S.C. §2000d, section 303 of the Age Discrimination Act of 1975, as amended, 42 U.S.C. §6102, section 202 of the Americans with Disabilities Act of 1990, 42 U.S.C. §12132, and Federal transit law at 49 U.S.C. §5332, the vendor agrees that it will not discriminate against any employee or applicant for employment because of race, color, creed, national origin, sex, age, or disability. In addition, the vendor agrees to comply with applicable Federal implementing regulations and other implementing requirements FTA may issue.

(2) **Equal Employment Opportunity** - The following equal employment opportunity requirements apply:

(a) **Race, Color, Creed, National Origin, Sex** - In accordance with Title VI of the CRA, as amended, 42 U.S.C. §2000e, and Federal transit laws at 49 U.S.C. §5332, the vendor agrees to comply with all applicable equal employment opportunity requirements of U.S. DOL regulations, "Office of Federal Contract Compliance Programs, Equal Employment Opportunity, DOL," 41 C.F.R. Parts 60 et seq., (which implement Executive Order No. 11246, "Equal Employment Opportunity," as amended by Executive Order No. 11375, "Amending Executive Order 11246 Relating to Equal Employment Opportunity," 42 U.S.C. §2000e note), and with any applicable Federal statutes, executive orders, regulations and Federal policies that may in the future affect construction activities undertaken in the course of the Project. The vendor agrees to take affirmative action to ensure that applicants are employed & treated during employment without regard to their race, color, creed, national origin, sex or age. Action shall

include but not be limited to employment, upgrading, demotion, transfer, recruitment, layoff, termination, rates of pay or other forms of compensation; and selection for training, including apprenticeship. The vendor agrees to comply with any implementing requirements FTA may issue.

(b) Age - In accordance with section 4 of the Age Discrimination in Employment Act of 1967 (29 U.S.C. §§623 and 49 U.S.C. §5332), the vendor agrees to refrain from discrimination against present and prospective employees for reason of age. and comply with any implementing requirements FTA may issue.

(c) Disabilities - In accordance with section 102 of the Americans with Disabilities Act (42 U.S.C. §12112), the contractor agrees to comply with the requirements of U.S. Equal Employment Opportunity Commission, "Regulations to Implement the Equal Employment Provisions of the Americans with Disabilities Act," 29 C.F.R. Part 1630, pertaining to employment of persons with disabilities. and to comply with any implementing requirements FTA may issue.

K. Altoona Test Certification (for rolling stock purchases) (Check one of the following):

- The vehicle has been Altoona tested, report number: PTI-BT-R0809  
 The vehicle is exempt from testing IAW 49 CFR 665.  
 The vehicle is currently being tested at Altoona.

Funds will not be released until the purchasing agency gets a copy of the Altoona test report, as appropriate, per 49 CFR 665.

L. Incorporation of Federal Transit Administration (FTA) Terms

The preceding provisions include, in part, certain Standard Terms and Conditions required by DOT, whether or not expressly set forth in the preceding contract provisions. All contractual provisions required by DOT, as set forth in FTA circular 4220.1F are hereby incorporated by reference. Anything to the contrary herein notwithstanding, all FTA mandated terms shall be deemed to control in the event of a conflict with other provisions contained in this Agreement. The Contractor shall not perform any act, fail to perform any act, or refuse to comply with any transit agency requests which would cause the transit agency to violate FTA terms and conditions.

M. Application of Federal, State, & Local Laws, Regulations, & Directives (Federal Changes)

The VENDOR agrees that Federal laws and regulations control project award and implementation. The VENDOR understands and agrees that unless the recipient requests FTA approval in writing, the VENDOR may incur a violation of Federal laws or regulations or this agreement if it implements an alternative procedure or course of action not approved by FTA. The VENDOR understands and agrees that Federal laws, regulations, and directives applicable on the date on which Federal assistance is awarded may be modified from time to time. In particular, new Federal laws, regulations, and directives may become effective after the date the project agreement is effective, and might apply to that project agreement. The VENDOR agrees that the most recent versions of such Federal laws, regulations, and directives will apply to the administration of the project at any particular time.

N. Right of the Federal Government to Terminate

Upon written notice, the VENDOR agrees that the Federal Government may suspend or terminate all or any part of Federal assistance if terms of the project agreement are violated, if the Federal Government determines that the purposes of the laws authorizing the Project would not be adequately served by the continuation of Federal assistance for the Project., if reasonable progress on the Project is not made, if there is a violation of the project agreement that endangers substantial performance of the Project, or if the Federal Government determines that Federal assistance has been willfully misused by failing to make appropriate use of Project property. Termination of Federal assistance for the Project will not typically invalidate obligations properly incurred before the termination date to the extent those obligations cannot be canceled. The Federal Government reserves the right to require the refund of the entire amount of Federal assistance provided for the Project or a lesser amount.



O. Disputes, Breaches, Defaults, or Other Litigation

The VENDOR agrees that FTA has a vested interest in the settlement of any dispute, breach, default, or litigation involving the Project. Accordingly:

a. **Notification to FTA.** The VENDOR is aware that recipients of Federal assistance must notify FTA in writing of any current or prospective major dispute, breach, default, or litigation that may affect the Federal Government's interests in the Project or the administration or enforcement of Federal laws or regulations. If the Federal Government is to be named as a party to litigation for any reason, in any forum, the appropriate FTA Regional Counsel is to be notified in writing before doing so.

b. **Federal Interest in Recovery.** The VENDOR is aware that the Federal Government retains the right to a proportionate share, based on the percentage of the Federal share awarded for the Project, of proceeds derived from any third party recovery.

c. **Enforcement.** The VENDOR agrees to pursue its legal rights and remedies available under any third party contract or available under law or regulations.

d. **FTA Concurrence.** The VENDOR is aware that FTA reserves the right to concur in any compromise or settlement of any claim involving the Project.

e. **Alternative Dispute Resolution.** The VENDOR is aware that FTA encourages the use of alternative dispute resolution procedures, as may be appropriate.

P. Fly America

The Contractor agrees to comply with 49 U.S.C. 40118 (the "Fly America" Act) in accordance with the General Services Administration's regulations at 41 CFR Part 301-10, which provide that recipients and subrecipients of Federal funds and their contractors are required to use U.S. Flag air carriers for U.S Government-financed international air travel and transportation of personal effects or property, to the extent such service is available, unless travel by foreign air carrier is a matter of necessity, as defined by the Fly America Act. The Contractor shall submit, if a foreign air carrier was used, an appropriate certification or memorandum adequately explaining why service by a U.S. flag air carrier was not available or why it was necessary to use a foreign air carrier and shall, in any event, provide a certificate of compliance with the Fly America requirements. The Contractor agrees to include the requirements of this section in all subcontracts that may involve international air transportation.

Q. Recycled Products

The contractor agrees to comply with all the requirements of Section 6002 of the Resource Conservation and Recovery Act (RCRA), as amended (42 U.S.C. 6962), including but not limited to the 40 CFR Part 247, and Executive Order 12873, as they apply to the procurement of the items designated in Subpart B of 40 CFR 247.

R. Access for Individuals with Disabilities

The VENDOR agrees to comply with 49 U.S.C. § 5301(d), which states the Federal policy that elderly individuals and individuals with disabilities have the same right as other individuals to use public transportation services and facilities, and that special efforts shall be made in planning and designing those services and facilities to implement transportation accessibility rights for elderly individuals and individuals with disabilities. The VENDOR also agrees to comply with all applicable provisions of section 504 of the Rehabilitation Act of 1973, as amended, with 29 U.S. C. § 794, which prohibits discrimination on the basis of disability; with the Americans with Disabilities Act of 1990 (ADA), as amended, 42 U.S.C. §§ 12101 *et seq.*, which requires that accessible facilities and services be made available to individuals with disabilities; and with the Architectural Barriers Act of 1968, as amended, 42 U.S.C. §§ 4151 *et seq.*, which requires that buildings and public accommodations be accessible to individuals with disabilities; and with other laws and amendments thereto pertaining to access for individuals with disabilities that may be applicable. In addition, the VENDOR agrees to comply with applicable implementing Federal regulations any later amendments thereto, and agrees to follow applicable Federal directives except to the extent FTA approves otherwise in writing. Among those regulations and directives are: (1) U.S. DOT regulations, "Transportation Services for Individuals with Disabilities (ADA)," 49 C.F.R. Part 37; (2) U.S. DOT regulations, "Nondiscrimination on the Basis of Handicap in Programs and Activities Receiving or Benefiting from Federal Financial Assistance," 49 C.F.R. Part 27; (3) Joint U.S. Architectural and Transportation Barriers Compliance Board (U.S. ATBCB)/U.S. DOT regulations, "Americans With Disabilities (ADA) Accessibility Specifications for Transportation Vehicles," 36 C.F.R. Part 1192 and 49 C.F.R. Part 38; (4) U.S. DOJ regulations, "Nondiscrimination on the Basis of Disability in State and Local Government Services," 28 C.F.R. Part 35; (5) U.S.

DOJ regulations, "Nondiscrimination on the Basis of Disability by Public Accommodations and in Commercial Facilities," 28 C.F.R. Part 36; (6) U.S. General Services Administration (U.S. GSA) regulations, "Accommodations for the Physically Handicapped," 41 C.F.R. Subpart 101-19; (7) U.S. EEOC, "Regulations to Implement the Equal Employment Provisions of the Americans with Disabilities Act," 29 C.F.R. Part 1630; (8) U.S. Federal Communications Commission regulations, "Telecommunications Relay Services and Related Customer Premises Equipment for the Hearing and Speech Disabled," 47 C.F.R. Part 64, Subpart F; (9) U.S. ATBCB regulations, "Electronic and Information Technology Accessibility Standards," 36 C.F.R. Part 1194; (10) FTA regulations, "Transportation for Elderly and Handicapped Persons," 49 C.F.R. Part 609; and (11) Federal civil rights and nondiscrimination directives implementing the foregoing Federal laws and regulations, except to the extent the Federal Government determines otherwise in writing.

**II. Federal Motor Vehicle Safety Standards (FMVSS) Certification (for rolling stock purchases)**

Any vehicles provided by the vendor will comply with all applicable FMVSS. The vendor shall submit 1) manufacturer's FMVSS self-certification sticker information that the vehicle complies with relevant FMVSS or 2) manufacturer's certified statement that the contracted buses will not be subject to FMVSS regulations.

**FMVSS Certification**

Name of Company TEXAS BUS SALES, INC.	Printed Name of Person Completing Form DIANNE LEDET
Date 05-17-12	Signature <i>Dianne Ledet</i>

**III. REQUIRED CLAUSES FOR BIDS OVER \$100,000:**

The vendor agrees to include the following in subcontracts exceeding \$100,000 financed by the FTA, and certifies the following:

**A. Debarment and Suspension**

The vendor hereby certifies that it and its principals have not presently or within a three year period been debarred, suspended, proposed for debarment, declared ineligible or voluntarily excluded from covered transactions by any Federal agency; and the vendor hereby certifies that it and its principals have not presently or within a three-year period been convicted of or had a civil judgment rendered against them for the commission of a fraud or a criminal offense in connection with obtaining, attempting to obtain or performing a public (Federal, state or local) transaction; violation of Federal or state antitrust statutes; or commission of embezzlement, theft, forgery, bribery, falsification or destruction of records, making false statements or receiving stolen property.

**B. Clean Water & Air**

The vendor agrees to comply with all applicable standards, orders or regulations issued pursuant to the Federal Water Pollution Control Act, as amended, 33 U.S.C. 1251 et seq. The vendor agrees to comply with all applicable standards, orders or regulations issued pursuant to the Clean Air Act, as amended, 42 U.S.C. §§7401 et seq. The vendor agrees to report each violation to the Purchaser and understands and agrees that the Purchaser will, in turn, report each violation as required to assure notification to the FTA and the EPA.

**IV. REQUIRED CERTIFICATIONS FOR BIDS OVER \$100,000:**

The vendor agrees to include the following in subcontracts exceeding \$100,000 financed by the FTA, and certifies the following:

**A. Buy America** (Check where applicable):

- The vendor or offeror hereby certifies it will comply with the requirements of 49 USC 5323(j) and the applicable regulations in 49 CFR 661, providing Buy America compliant manufactured goods.
- The vendor or offeror cannot comply with the requirements 49 USC 5323(j), but may qualify for an exception to the requirement pursuant to the regulations in 49 CFR 661.

**Buy America Certification**

Name of Company TEXAS BUS SALES, INC.	Printed Name of Person Completing Form DIANNE LEDET
Date 05-17-12	Signature <i>Dianne Ledet</i>

*DL*

**B. Non-Lobbying**

The undersigned certifies to the best of his or her knowledge and belief that:

1) No federal appropriated funds have been paid or will be paid, by or on behalf of the undersigned to any person for influencing or attempting to influence any officer or employee of an agency, a member of Congress, an officer or employee of Congress in connection with the awarding of any federal contract, the making of any federal grant, the making of any federal loan, the entering into of any cooperative agreement, and the extension, continuation, renewal, amendment, or modification of any federal contract, grant, loan, or cooperative agreement.

2) If any funds other than federal appropriated funds have been paid or will be paid to any person for influencing or attempting to influence an officer or employee of any agency, a member of Congress, an officer or employee of Congress, or an employee of a member of Congress in connection with this federal contract, grant, loan or cooperative agreement, the undersigned shall complete and submit standard form LLL, "Disclosure Form to Report Lobbying", in accordance with its instructions.

3) The undersigned shall require that the language of this certification be included in the award documents for all subawards at all tiers (including subcontracts, subgrants, and contracts under grants, loans, and cooperative agreements and that all subrecipients shall certify and disclose accordingly.

This certification is a material representation of fact upon which reliance was placed when this transaction was made or entered into. Submission of this certification is a prerequisite for making or entering into this transaction imposed by section 1352, title 31, USC. Any person who fails to file the required certification shall be subject to a civil penalty of not less than \$10,000 and not more than \$100,000 for each such failure.

**Lobbying and Disclosure Certification**

Name of Company TEXAS BUS SALES, INC.	Printed Name of Person Completing Form DIANNE LEDET
Date 05-17-12	Signature <i>Dianne Ledet</i>

**V. SPECIAL PROJECT TYPE PROVISIONS - the following addenda are attached and endorsed as appropriate:**

- A. Construction or Architectural & Engineering Projects
- B. Transit Operations or Management Projects
- C. Intelligent Transportation System or Research & Development

**VI. CERTIFICATION TO PURCHASER:**

- A. The undersigned vendor certifies that the manufactured good(s) furnished will meet or exceed the specifications, and/or that services rendered will comply with the terms of the solicitation or contract.
- B. The undersigned vendor certifies that it has read all of the bid, proposal, or contract documents and agrees to abide by the terms, certifications, and conditions thereof.

Name of Company TEXAS BUS SALES, INC.	Address 1605 WEST 34TH STREET HOUSTON TX 77018
	Printed Name of Person Completing Form DIANNE LEDET
Telephone (713) 681-3600	Signature <i>Dianne Ledet</i>
Date 05-17-12	SS# or Tax ID # 76-0359837
Description of Commodity or Service BUS SALES & SERVICE	
Disadvantaged Business Enterprise Information	
Type of Organization (circle)	
<input type="checkbox"/> Sole Proprietorship <input type="checkbox"/> General Proprietorship	
<input type="checkbox"/> Is your firm a DBE? <input type="checkbox"/> (yes) <input type="checkbox"/> (no) <input type="checkbox"/> Corporation <input type="checkbox"/> Limited Partnership	
<input type="checkbox"/> If yes, what type? <input type="checkbox"/> Limited Proprietorship	

*DL*

# Amerivan PT

EIDorado  
National - Kansas  
Thor Industries Mobility Division



## Consumer Features . . . Commercial Durability

- The Amerivan PT from EIDorado National represents the best in a premium quality lowered-floor minivan for light transit use.
- All the renowned construction features of the consumer version, including the **standard all stainless steel floor**, in an economical, durable commercial version.



Paratransit Vehicle

## Functional Features



Our standard ramp in position and "Quick Release" removable front passenger seating



Optional interior mounted spare tire with cover

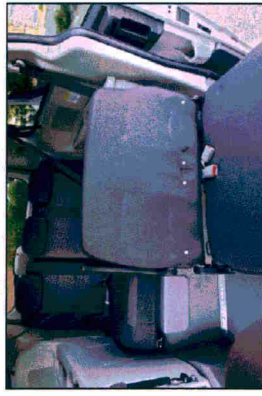

Optional 2 passenger fold-away middle seat

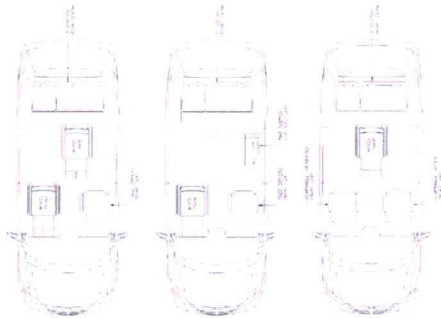

Every EIDorado National component of your Amerivan has undergone rigid testing for safety and performance. The crash tested Amerivan design meets or exceeds all applicable U.S. vehicle safety standard.



Optional DOT package

## Standard Features

- Safe, commercial grade non-slip flooring made of skid-resistant durable vinyl.
- Easy-to-operate, non-skid manual fold-out ramp.
- Quality tie-down belts – we install the premier tie-down belt system made by Q-Straint – the industry benchmark for safety. You can rest assured that your wheelchair or motorized chair is securely fastened in your van. We also provide two floor tracks so you can determine where to hook the belts.
- The crash-tested Amerivan PT design meets or exceeds all applicable US motor vehicle safety standards.
- The Amerivan PT is built to last... all air conditioning, heating and braking lines are constructed in durable stainless steel. In fact, we're the only lowered-floor minivan you can buy with an **all stainless steel floor**.

### WARRANTY

- 3-year, 36,000 mile warranty

### PREMIUM QUALITY CONVERSION



Reliable workmanship

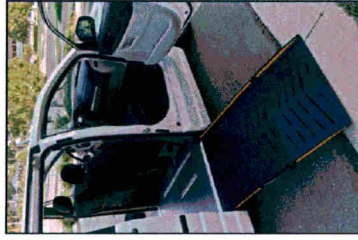

Sturdy manual fold-out ramp has an easy-to-use swing-out gate feature for quick and clear access for all passengers. Optional fold-away middle seat also shown.



"Quick Release" seating



Rear cargo area

# Standard Conversion Features

## 14" Lowered Stainless Steel Floor!

- ADA 56" high entry door and lighting
- ADA 31" wide manual ramp
- 54" long manual fold-out ramp
- 3 passenger rear seat modification
- Permanent driver's seat
- Removable passenger seat
- Q'Straint wheelchair track (RF/Mid locations)
- 1 set - Q'Straint restraint belts
- Grab handles - A Pillar/B Pillars
- Back-up alarm
- Commercial grade non-slip Altro flooring
- Swing-out ramp feature

### DIMENSIONS

- Overall height of van 72<sup>3</sup>/<sub>4</sub>"
- Door opening, usable height 56"
- Interior height at center of van 60"
- Interior height at driver and passenger position 60"
- Ground clearance (loaded) 5<sup>1</sup>/<sub>2</sub>"
- Overall interior floor length 88"
- Interior width at "B-pillar" 60"

### STANDARD CHASSIS SPECIFICATIONS

- 6,050 lb. GVWR
- 3.3 liter V6 engine
- 4-speed automatic transmission
- Driver & passenger front impact air bags
- Front heating/air conditioning
- P225/65 R 16 BSW all season tires
- 20 gallon fuel tank

## Popular Optional Equipment

(Note: This is only a partial listing of optional equipment. For more complete information, contact your EIDorado National representative.)

### OPTIONAL EQUIPMENT

- Rear air conditioning/heating
- Additional Q'Straint belts
- 2 passenger fold-away Freedman™ seating – vinyl/OEM fabric
- Automatic load leveling air suspension
- Interior mounted spare tire with cover

### OPTIONAL DOT PACKAGE

- First aid kit
- Fire extinguisher
- Reflective triangle kit



With our 250,000 sq. ft. state-of-the-art facility, we are able to provide timely delivery in addition to the exceptional quality that sets the standard in our industry.

At EIDorado National, we constantly improve our product; as a result all specifications and dimensions are subject to change without notice.



EIDorado   
National - Kansas  
Thor Industries Mobility Division

1655 Wall Street • Salina, KS 67401 • (866) 392-6300 • (785) 827-1033

[www.amerivans.com](http://www.amerivans.com)



Printed on recycled paper as part of EIDorado National's continuous effort to minimize waste and conserve our natural resources.





## Features

### Warranty

Because we build among the best buses in the industry, we can afford to provide among the best warranties in the industry. In addition to the manufacturer's warranty on chassis and tires, the Amerivan is covered for:

- 7 years or 70,000 miles on the EIDorado National installed floor and ramp
- 3 year or 36,000 miles on all other parts\*

\*This is merely a summary. For full terms of the warranty, please review the following.

### *EIDorado National Amerivan Limited Warranty*

**EIDorado National Corporation (ENC)** warrants to the original purchaser of this product that EIDorado National will repair or replace, at its option, any parts that fail because of defective material or workmanship as follows:

- Repair or replace for a period of 7 years or 70,000 miles (112,000 km), whichever comes first, the structural metal component of the EIDorado National installed floor and ramp. These components are warranted for "rust-through" damage. Surface rust is not covered.
- Repair or replace for a period of 3 years from the in-service date or 36,000 miles (58,000 km), whichever occurs first, all other Amerivan components. Maintenance items and normal wear and tear excluded.
- Labor costs for specified parts replaced under this warranty for a period of three years or 36,000 miles from date of purchase. An EIDorado National rate schedule determines the parts covered and labor allowed. Under normal circumstances, an authorized EIDorado National Amerivan service technician must perform warranty work. In an emergency, and if service from a Amerivan service technician is not readily available, it is the owners responsibility to contact EIDorado National for authorization prior to commencement of any repair, and EIDorado National reserves the right to limit the extent of those repairs. Unauthorized repair or parts replacement by someone other than an authorized Amerivan service technician is not covered by this warranty. EIDorado National also reserves the right to require that defective parts be returned for inspection prior to paying warranty claims. Diagnostic work or troubleshooting is not covered by this warranty.

EIDorado National reserves the right to discontinue models or options, change specifications, materials, equipment or design at any time without notice and without incurring obligation.

This warranty is in lieu of any other warranty expressed or implied. This warranty covers only those parts installed by EIDorado National and is intended to supplement the vehicle manufacturer warranty. Refer to the vehicle manufacturer warranty coverage of original vehicle equipment.

This warranty does not cover damage caused by accident, road hazard, misuse, lack of proper maintenance, failure to follow towing, hoisting, and other operating instructions.

**NOTE:** EIDorado National recommends that this product be inspected by an authorized EIDorado National service technician at least once every six months or sooner if necessary. Any required maintenance or repair should be performed at that time.

**WARNING:** This product has been designed and manufactured to exact specifications. Any modification of this product can be dangerous.

This Warranty Is Void If:

- The conversion has been maintained or repaired by someone other than a authorized EIDorado National American service technician, or by a person not authorized by EIDorado National to perform such maintenance or repair.
- The conversion has been modified or altered in any respect from its original design without written authorization by EIDorado National.

**EIDorado National disclaims liability for any personal injury or property damage that results from operation of an EIDorado National product that has been modified from the original EIDorado National design. No person or company is authorized to change the design of this EIDorado National product without written authorization by EIDorado National.**

**EIDorado National's obligation under this warranty is exclusively limited to the repair or exchange of parts that fail within the applicable warranty period.**

**EIDorado National assumes no responsibility for expenses or damages, including incidental or consequential damages. Some states do not allow the exclusion or limitation of incidental or consequential damages, so the above limitation or exclusion may not apply.**

**Important: The warranty registration card must be completed and returned to EIDorado National within twenty (20) days after installation of this EIDorado National product for the warranty to be valid. The warranty is not transferable.**

**The warranty gives specific legal rights. There may be other rights that vary from state to state.**

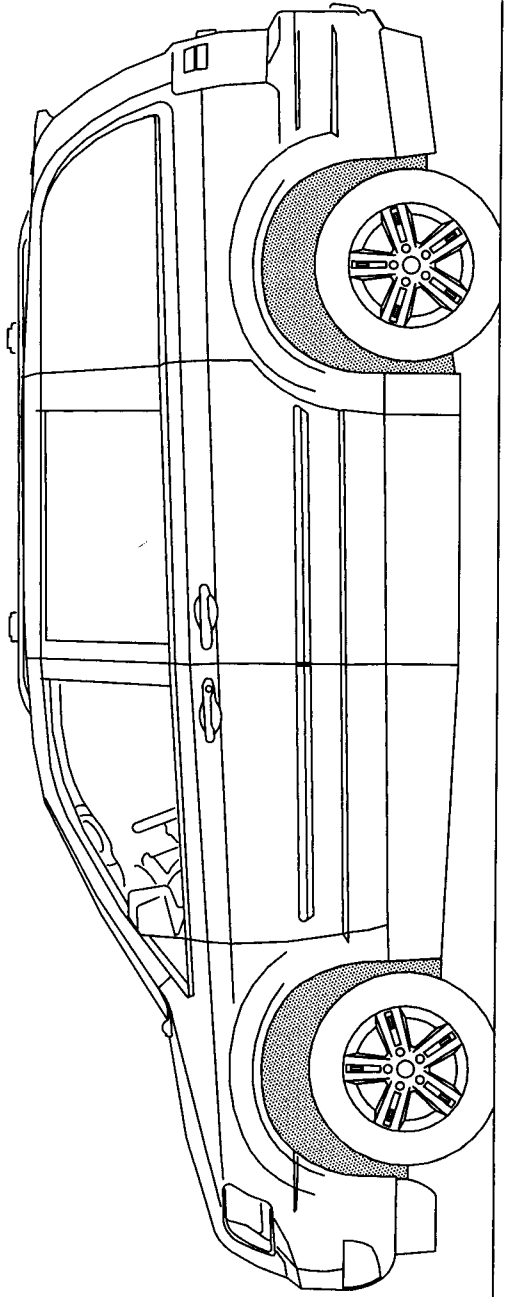
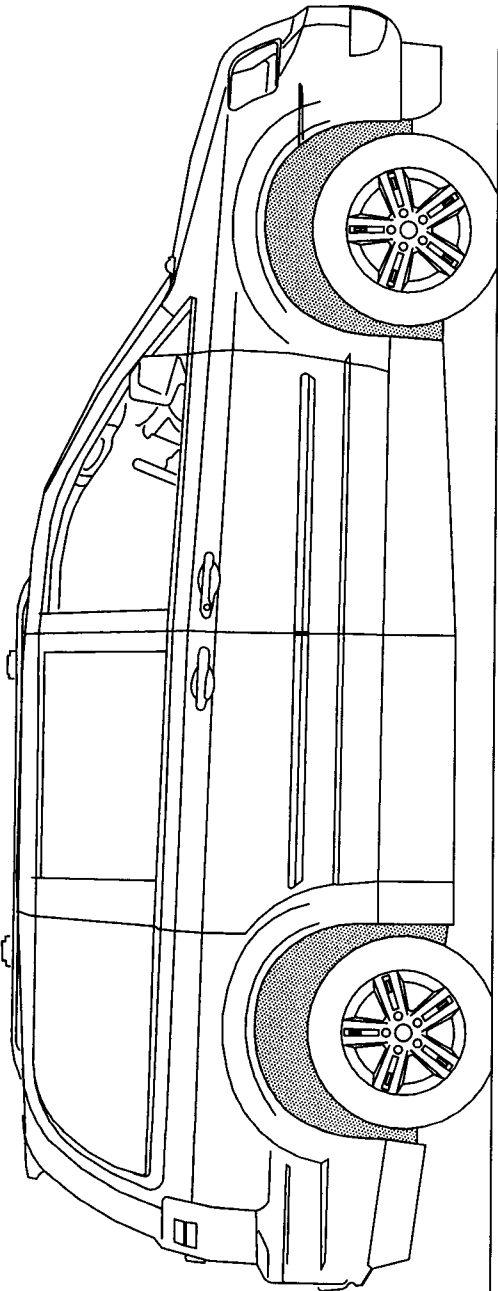
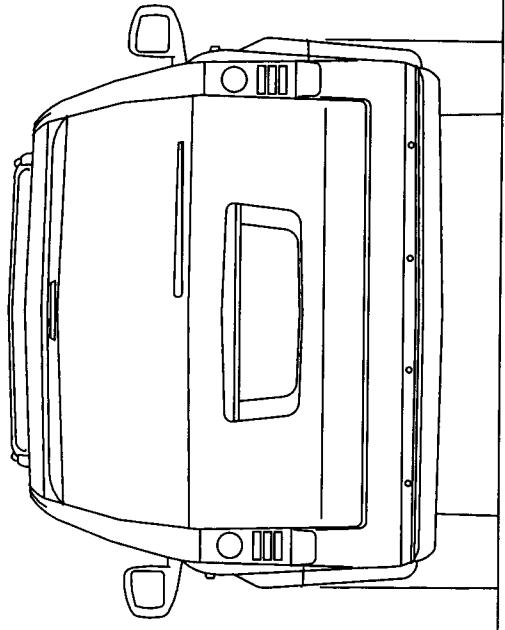
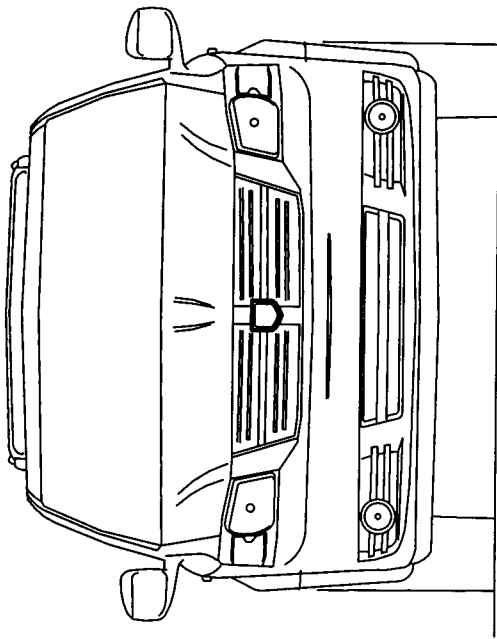

# Vehicle Dimensions

(SPECIFICATIONS SUBJECT TO CHANGE WITHOUT NOTICE)

2008/09 DODGE GRAND CARAVAN  
2008/09 CHRYSLER TOWN AND COUNTRY

## Amerivan

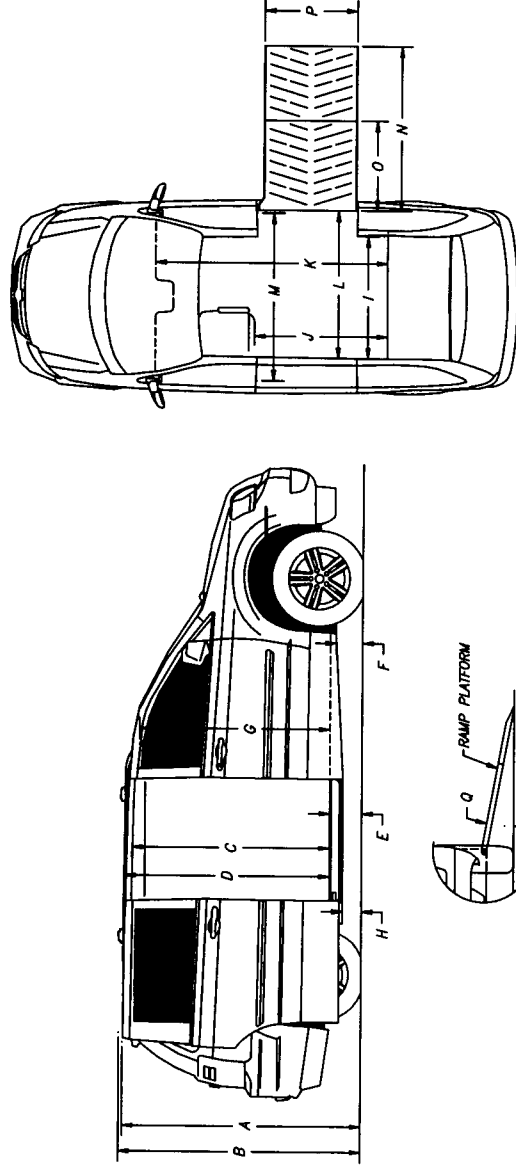

### FOLD OUT RAMP

ITEM	DESCRIPTION	DIMENSION
A	OVERALL HEIGHT OF VAN	72 3/4"
B	OVERALL HEIGHT OF VAN, (WITH LUGGAGE RACK)	75"
C	DOOR OPENING, USABLE HEIGHT	56"
D	INTERIOR HEIGHT AT CENTER OF VAN WITH CONSOLE	57 1/2"
D	INTERIOR HEIGHT AT CENTER OF VAN WITHOUT CONSOLE	60 1/2"
E	HEIGHT AT FLOOR, (NORMAL)	11"
F	GROUND CLEARANCE AT SIDE DOORS, (NORMAL)	7"
G	INTERIOR HEIGHT AT DRIVER AND PASSENGER POSITION	60"
H	GROUND CLEARANCE AT FRAME, (EMPTY)	7 5/8"
I	INTERIOR WIDTH	46 1/2"
J	INTERIOR FLOOR LENGTH FROM BEHIND FRONT SEAT	55 1/2"
K	OVERALL INTERIOR FLOOR LENGTH	87"
L	INTERIOR WIDTH AT MIDDLE OF RAMP	66"
M	INTERIOR WIDTH BEHIND DRIVER'S SEAT AT B-PILLAR	60"
N	RAMP LENGTH	54"
O	RAMP LENGTH, (FIRST SECTION ONLY)	34 1/2"
P	USABLE RAMP WIDTH	31"
Q	RAMP ANGLE WITH VAN KNELT	7°
	GROSS VEHICLE WEIGHT RATING (LBS)	6050

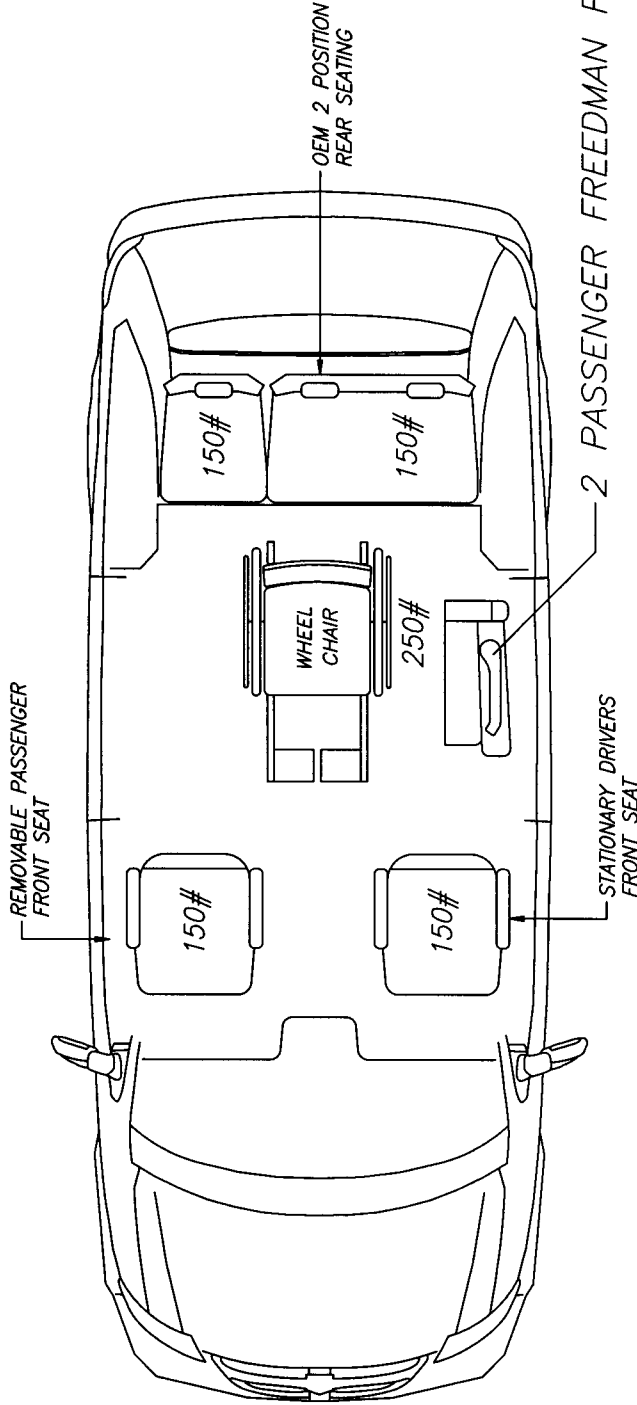

LAYOUT WITH 1 WHEELCHAIR

2 AMBULATORY REAR	2x150 = 300lb	6050lb	VEHICLE GVWR
1 WHEEL CHAIR MIDDLE	1x250 = 250lb	- 850lb	PAYLOAD
2 AMBULATORY FRONT	2x150 = 300lb	5200lb	MAX ALLOWABLE CURB WEIGHT
		- 4744lb	ACTUAL WEIGHT W/ ALL SEATS
			UNDER MAX
		TOTAL = 850lb	

NOTE: AMBULATORY 150lb  
WHEELCHAIR & OCCUPANT 250lb

NEXT ASSEMBLY: NONE	DRAWING INFORMATION								
SUPERCEDES: NONE	DRAWN: GREEN CKD:								
DO NOT SCALE DRAWING	DATE: 1/8/09								
MARK PART NUMBER AND REVISION ON ALL PARTS	SCALE: 1:32								
THIS DRAWING IS THE PROPERTY OF ELDORADO NATIONAL COMPANY, A THOR INDUSTRIES COMPANY AND IS NOT TO BE DUPLICATED OR USED IN ANY WAY DETRIMENTAL TO THEIR BEST INTEREST.	TOLERANCE UNLESS SPECIFIED								
	FRACTIONS ± 1/16								
	DECIMALS .00 ± .06								
	ANGLES + 1 DEG.								
	REV. BY DATE								
	- SG 1/8/09								
	RELEASE TO PRODUCTION								
	DESCRIPTION								
	RELEASE #								

**Eldorado National**



— a THOR company — 1655 WALL STREET, SALINA, KS. 67401

TITLE: 2009 DODGE RT FLOOR PLAN LAYOUT 09

MATERIAL SPEC: N/A

PART NUMBER

RT FLOOR PLAN 09

PAGE

1 of 1

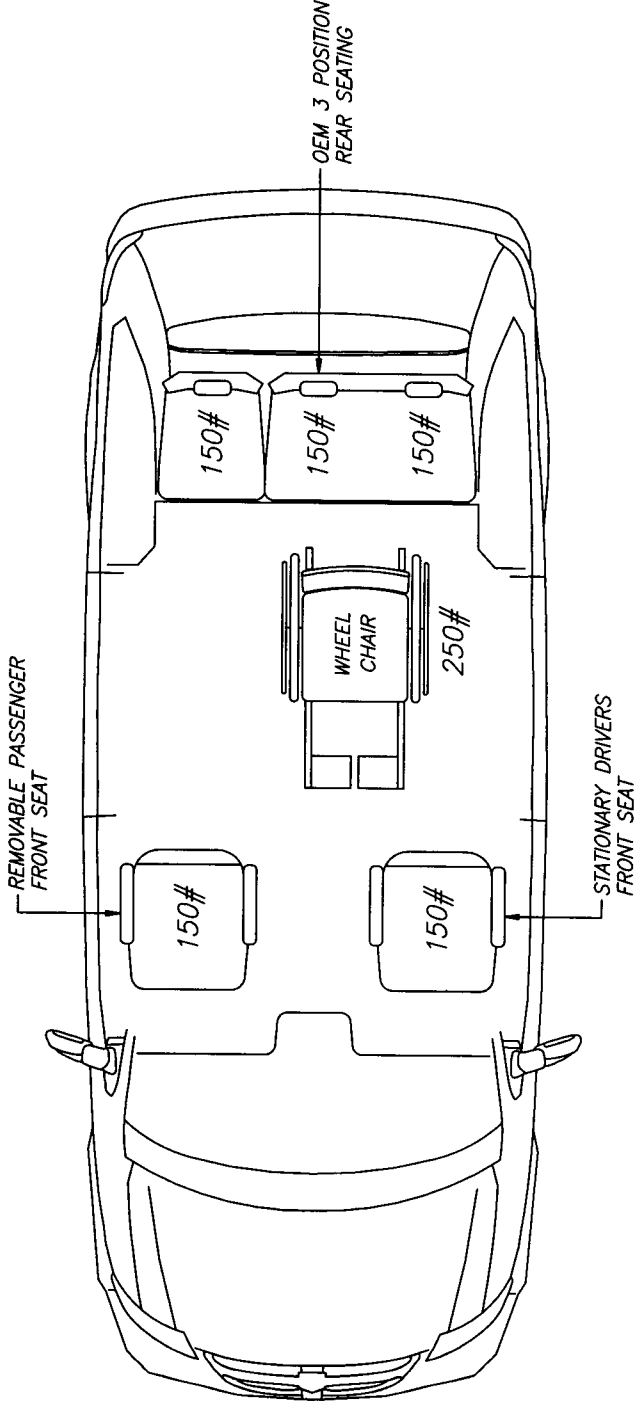

LAYOUT WITH 1 WHEELCHAIR

3 AMBULATORY REAR	3x150 = 450lb	6050lb	VEHICLE GVWR
1 MOBILITY AID MIDDLE	1x250 = 250lb	- 1000lb	PAYLOAD
2 AMBULATORY FRONT	2x150 = 300lb	5050lb	MAX ALLOWABLE CURB WEIGHT
	TOTAL = 1000lb	- 4734lb	ACTUAL WEIGHT W/ ALL SEATS
		316lb	UNDER MAX

NOTE: AMBULATORY 150lb  
WHEELCHAIR & OCCUPANT 250lb

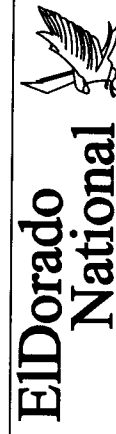

— a THOR company — 1655 WALL STREET SALINA, KS. 67401

TITLE:  
2009 DODGE RT FLOOR PLAN  
LAYOUT 04

MATERIAL SPEC:  
N/A

REVISION	DATE	BY	DESCRIPTION
- SG	1/8/09		RELEASE TO PRODUCTION
DRAWING INFORMATION			
DRAWN: GREEN	CHKD:		
DATE: 1/8/09	SIZE: A		
SCALE: 1:32	WGT:		
TOLERANCE UNLESS SPECIFIED			
FRACTIONS ± 1/16			
DECIMALS .00 ± .06			
ANGLES + 1 DEG.			
THIS DRAWING IS THE PROPERTY OF EL DORADO NATIONAL COMPANY, A THOR INDUSTRIES COMPANY AND IS NOT TO BE DUPLICATED OR USED IN ANY WAY DETRIMENTAL TO THEIR BEST INTEREST.			
NEXT ASSEMBLY: NONE			
SUPERCEDES: NONE			
MARK PART NUMBER AND REVISION ON ALL PARTS			
PART NUMBER	RELEASE #		
RT FLOOR PLAN 04	1	OF 1	



**ALTOONA BUS TESTING CERTIFICATION**

Eldorado National (Kansas), Inc. hereby certifies that the vehicles being offered for sale have been fully tested as a "family of vehicles" for a minimum service life of four (4) years or 100,000 miles at the Altoona Bus Testing Center as required by the Surface Transportation and Uniform Relocation Assistance Act of 1987 and in accordance with CFR 49, Part 665, as amended.

  
Signed, Eldorado National (Kansas), Inc.

05-17-12  
Date

Senior VP/General Manager  
Title

## Request for Taxpayer Identification Number and Certification

**Give Form to the  
 requester. Do not  
 send to the IRS.**

Print or type  
 See Specific Instructions on page 2.

Name (as shown on your income tax return) <b>TEXAS BUS SALES, INC.</b>	
Business name/disregarded entity name, if different from above	
Check appropriate box for federal tax classification (required): <input type="checkbox"/> Individual/sole proprietor <input checked="" type="checkbox"/> C Corporation <input type="checkbox"/> S Corporation <input type="checkbox"/> Partnership <input type="checkbox"/> Trust/estate <input type="checkbox"/> Limited liability company. Enter the tax classification (C=C corporation, S=S corporation, P=partnership) ▶ _____ <input type="checkbox"/> Exempt payee <input type="checkbox"/> Other (see instructions) ▶ _____	
Address (number, street, and apt. or suite no.) <b>1605 WEST 34TH STREET</b>	Requester's name and address (optional)
City, state, and ZIP code <b>HOUSTON TX 77018</b>	
List account number(s) here (optional)	

### Part I Taxpayer Identification Number (TIN)

Enter your TIN in the appropriate box. The TIN provided must match the name given on the "Name" line to avoid backup withholding. For individuals, this is your social security number (SSN). However, for a resident alien, sole proprietor, or disregarded entity, see the Part I instructions on page 3. For other entities, it is your employer identification number (EIN). If you do not have a number, see *How to get a TIN* on page 3.

Social security number									

**Note.** If the account is in more than one name, see the chart on page 4 for guidelines on whose number to enter.

Employer identification number

### Part II Certification

Under penalties of perjury, I certify that:

1. The number shown on this form is my correct taxpayer identification number (or I am waiting for a number to be issued to me), and
2. I am not subject to backup withholding because: (a) I am exempt from backup withholding, or (b) I have not been notified by the Internal Revenue Service (IRS) that I am subject to backup withholding as a result of a failure to report all interest or dividends, or (c) the IRS has notified me that I am no longer subject to backup withholding, and
3. I am a U.S. citizen or other U.S. person (defined below).

**Certification instructions.** You must cross out item 2 above if you have been notified by the IRS that you are currently subject to backup withholding because you have failed to report all interest and dividends on your tax return. For real estate transactions, item 2 does not apply. For mortgage interest paid, acquisition or abandonment of secured property, cancellation of debt, contributions to an individual retirement arrangement (IRA), and generally, payments other than interest and dividends, you are not required to sign the certification, but you must provide your correct TIN. See the instructions on page 4.

<b>Sign Here</b>	Signature of U.S. person ▶ <i>Shianne Ledet</i>	Date ▶ 05-17-12
------------------	---	-----------------

### General Instructions

Section references are to the Internal Revenue Code unless otherwise noted.

#### Purpose of Form

A person who is required to file an information return with the IRS must obtain your correct taxpayer identification number (TIN) to report, for example, income paid to you, real estate transactions, mortgage interest you paid, acquisition or abandonment of secured property, cancellation of debt, or contributions you made to an IRA.

Use Form W-9 only if you are a U.S. person (including a resident alien), to provide your correct TIN to the person requesting it (the requester) and, when applicable, to:

1. Certify that the TIN you are giving is correct (or you are waiting for a number to be issued),
2. Certify that you are not subject to backup withholding, or
3. Claim exemption from backup withholding if you are a U.S. exempt payee. If applicable, you are also certifying that as a U.S. person, your allocable share of any partnership income from a U.S. trade or business is not subject to the withholding tax on foreign partners' share of effectively connected income.

**Note.** If a requester gives you a form other than Form W-9 to request your TIN, you must use the requester's form if it is substantially similar to this Form W-9.

**Definition of a U.S. person.** For federal tax purposes, you are considered a U.S. person if you are:

- An individual who is a U.S. citizen or U.S. resident alien,
- A partnership, corporation, company, or association created or organized in the United States or under the laws of the United States,
- An estate (other than a foreign estate), or
- A domestic trust (as defined in Regulations section 301.7701-7).

**Special rules for partnerships.** Partnerships that conduct a trade or business in the United States are generally required to pay a withholding tax on any foreign partners' share of income from such business. Further, in certain cases where a Form W-9 has not been received, a partnership is required to presume that a partner is a foreign person, and pay the withholding tax. Therefore, if you are a U.S. person that is a partner in a partnership conducting a trade or business in the United States, provide Form W-9 to the partnership to establish your U.S. status and avoid withholding on your share of partnership income.

The person who gives Form W-9 to the partnership for purposes of establishing its U.S. status and avoiding withholding on its allocable share of net income from the partnership conducting a trade or business in the United States is in the following cases:

- The U.S. owner of a disregarded entity and not the entity,
- The U.S. grantor or other owner of a grantor trust and not the trust, and
- The U.S. trust (other than a grantor trust) and not the beneficiaries of the trust.

**Foreign person.** If you are a foreign person, do not use Form W-9. Instead, use the appropriate Form W-8 (see Publication 515, Withholding of Tax on Nonresident Aliens and Foreign Entities).

**Nonresident alien who becomes a resident alien.** Generally, only a nonresident alien individual may use the terms of a tax treaty to reduce or eliminate U.S. tax on certain types of income. However, most tax treaties contain a provision known as a "saving clause." Exceptions specified in the saving clause may permit an exemption from tax to continue for certain types of income even after the payee has otherwise become a U.S. resident alien for tax purposes.

If you are a U.S. resident alien who is relying on an exception contained in the saving clause of a tax treaty to claim an exemption from U.S. tax on certain types of income, you must attach a statement to Form W-9 that specifies the following five items:

1. The treaty country. Generally, this must be the same treaty under which you claimed exemption from tax as a nonresident alien.
2. The treaty article addressing the income.
3. The article number (or location) in the tax treaty that contains the saving clause and its exceptions.
4. The type and amount of income that qualifies for the exemption from tax.
5. Sufficient facts to justify the exemption from tax under the terms of the treaty article.

**Example.** Article 20 of the U.S.-China income tax treaty allows an exemption from tax for scholarship income received by a Chinese student temporarily present in the United States. Under U.S. law, this student will become a resident alien for tax purposes if his or her stay in the United States exceeds 5 calendar years. However, paragraph 2 of the first Protocol to the U.S.-China treaty (dated April 30, 1984) allows the provisions of Article 20 to continue to apply even after the Chinese student becomes a resident alien of the United States. A Chinese student who qualifies for this exception (under paragraph 2 of the first protocol) and is relying on this exception to claim an exemption from tax on his or her scholarship or fellowship income would attach to Form W-9 a statement that includes the information described above to support that exemption.

If you are a nonresident alien or a foreign entity not subject to backup withholding, give the requester the appropriate completed Form W-8.

**What is backup withholding?** Persons making certain payments to you must under certain conditions withhold and pay to the IRS a percentage of such payments. This is called "backup withholding." Payments that may be subject to backup withholding include interest, tax-exempt interest, dividends, broker and barter exchange transactions, rents, royalties, nonemployee pay, and certain payments from fishing boat operators. Real estate transactions are not subject to backup withholding.

You will not be subject to backup withholding on payments you receive if you give the requester your correct TIN, make the proper certifications, and report all your taxable interest and dividends on your tax return.

#### Payments you receive will be subject to backup withholding if:

1. You do not furnish your TIN to the requester,
2. You do not certify your TIN when required (see the Part II instructions on page 3 for details),
3. The IRS tells the requester that you furnished an incorrect TIN,
4. The IRS tells you that you are subject to backup withholding because you did not report all your interest and dividends on your tax return (for reportable interest and dividends only), or
5. You do not certify to the requester that you are not subject to backup withholding under 4 above (for reportable interest and dividend accounts opened after 1983 only).

Certain payees and payments are exempt from backup withholding. See the instructions below and the separate Instructions for the Requester of Form W-9.

Also see *Special rules for partnerships* on page 1.

### Updating Your Information

You must provide updated information to any person to whom you claimed to be an exempt payee if you are no longer an exempt payee and anticipate receiving reportable payments in the future from this person. For example, you may need to provide updated information if you are a C corporation that elects to be an S corporation, or if you no longer are tax exempt. In addition, you must furnish a new Form W-9 if the name or TIN changes for the account, for example, if the grantor of a grantor trust dies.

### Penalties

**Failure to furnish TIN.** If you fail to furnish your correct TIN to a requester, you are subject to a penalty of \$50 for each such failure unless your failure is due to reasonable cause and not to willful neglect.

**Civil penalty for false information with respect to withholding.** If you make a false statement with no reasonable basis that results in no backup withholding, you are subject to a \$500 penalty.

**Criminal penalty for falsifying information.** Willfully falsifying certifications or affirmations may subject you to criminal penalties including fines and/or imprisonment.

**Misuse of TINs.** If the requester discloses or uses TINs in violation of federal law, the requester may be subject to civil and criminal penalties.

### Specific Instructions

#### Name

If you are an individual, you must generally enter the name shown on your income tax return. However, if you have changed your last name, for instance, due to marriage without informing the Social Security Administration of the name change, enter your first name, the last name shown on your social security card, and your new last name.

If the account is in joint names, list first, and then circle, the name of the person or entity whose number you entered in Part I of the form.

**Sole proprietor.** Enter your individual name as shown on your income tax return on the "Name" line. You may enter your business, trade, or "doing business as (DBA)" name on the "Business name/disregarded entity name" line.

**Partnership, C Corporation, or S Corporation.** Enter the entity's name on the "Name" line and any business, trade, or "doing business as (DBA) name" on the "Business name/disregarded entity name" line.

**Disregarded entity.** Enter the owner's name on the "Name" line. The name of the entity entered on the "Name" line should never be a disregarded entity. The name on the "Name" line must be the name shown on the income tax return on which the income will be reported. For example, if a foreign LLC that is treated as a disregarded entity for U.S. federal tax purposes has a domestic owner, the domestic owner's name is required to be provided on the "Name" line. If the direct owner of the entity is also a disregarded entity, enter the first owner that is not disregarded for federal tax purposes. Enter the disregarded entity's name on the "Business name/disregarded entity name" line. If the owner of the disregarded entity is a foreign person, you must complete an appropriate Form W-8.

**Note.** Check the appropriate box for the federal tax classification of the person whose name is entered on the "Name" line (Individual/sole proprietor, Partnership, C Corporation, S Corporation, Trust/estate).

**Limited Liability Company (LLC).** If the person identified on the "Name" line is an LLC, check the "Limited liability company" box only and enter the appropriate code for the tax classification in the space provided. If you are an LLC that is treated as a partnership for federal tax purposes, enter "P" for partnership. If you are an LLC that has filed a Form 8832 or a Form 2553 to be taxed as a corporation, enter "C" for C corporation or "S" for S corporation. If you are an LLC that is disregarded as an entity separate from its owner under Regulation section 301.7701-3 (except for employment and excise tax), do not check the LLC box unless the owner of the LLC (required to be identified on the "Name" line) is another LLC that is not disregarded for federal tax purposes. If the LLC is disregarded as an entity separate from its owner, enter the appropriate tax classification of the owner identified on the "Name" line.

**Other entities.** Enter your business name as shown on required federal tax documents on the "Name" line. This name should match the name shown on the charter or other legal document creating the entity. You may enter any business, trade, or DBA name on the "Business name/disregarded entity name" line.

**Exempt Payee**

If you are exempt from backup withholding, enter your name as described above and check the appropriate box for your status, then check the "Exempt payee" box in the line following the "Business name/disregarded entity name," sign and date the form.

Generally, individuals (including sole proprietors) are not exempt from backup withholding. Corporations are exempt from backup withholding for certain payments, such as interest and dividends.

**Note.** If you are exempt from backup withholding, you should still complete this form to avoid possible erroneous backup withholding.

The following payees are exempt from backup withholding:

1. An organization exempt from tax under section 501(a), any IRA, or a custodial account under section 403(b)(7) if the account satisfies the requirements of section 401(f)(2),
  2. The United States or any of its agencies or instrumentalities,
  3. A state, the District of Columbia, a possession of the United States, or any of their political subdivisions or instrumentalities,
  4. A foreign government or any of its political subdivisions, agencies, or instrumentalities, or
  5. An international organization or any of its agencies or instrumentalities.
- Other payees that may be exempt from backup withholding include:
6. A corporation,
  7. A foreign central bank of issue,
  8. A dealer in securities or commodities required to register in the United States, the District of Columbia, or a possession of the United States,
  9. A futures commission merchant registered with the Commodity Futures Trading Commission,
  10. A real estate investment trust,
  11. An entity registered at all times during the tax year under the Investment Company Act of 1940,
  12. A common trust fund operated by a bank under section 584(a),
  13. A financial institution,
  14. A middleman known in the investment community as a nominee or custodian, or
  15. A trust exempt from tax under section 664 or described in section 4947.

The following chart shows types of payments that may be exempt from backup withholding. The chart applies to the exempt payees listed above, 1 through 15.

IF the payment is for . . .	THEN the payment is exempt for . . .
Interest and dividend payments	All exempt payees except for 9
Broker transactions	Exempt payees 1 through 5 and 7 through 13. Also, C corporations.
Barter exchange transactions and patronage dividends	Exempt payees 1 through 5
Payments over \$600 required to be reported and direct sales over \$5,000 <sup>1</sup>	Generally, exempt payees 1 through 7 <sup>2</sup>

<sup>1</sup> See Form 1099-MISC, Miscellaneous Income, and its instructions.

<sup>2</sup> However, the following payments made to a corporation and reportable on Form 1099-MISC are not exempt from backup withholding: medical and health care payments, attorneys' fees, gross proceeds paid to an attorney, and payments for services paid by a federal executive agency.

**Part I. Taxpayer Identification Number (TIN)**

**Enter your TIN in the appropriate box.** If you are a resident alien and you do not have and are not eligible to get an SSN, your TIN is your IRS individual taxpayer identification number (ITIN). Enter it in the social security number box. If you do not have an ITIN, see *How to get a TIN* below.

If you are a sole proprietor and you have an EIN, you may enter either your SSN or EIN. However, the IRS prefers that you use your SSN.

If you are a single-member LLC that is disregarded as an entity separate from its owner (see *Limited Liability Company (LLC)* on page 2), enter the owner's SSN (or EIN, if the owner has one). Do not enter the disregarded entity's EIN. If the LLC is classified as a corporation or partnership, enter the entity's EIN.

**Note.** See the chart on page 4 for further clarification of name and TIN combinations.

**How to get a TIN.** If you do not have a TIN, apply for one immediately. To apply for an SSN, get Form SS-5, Application for a Social Security Card, from your local Social Security Administration office or get this form online at [www.ssa.gov](http://www.ssa.gov). You may also get this form by calling 1-800-772-1213. Use Form W-7, Application for IRS Individual Taxpayer Identification Number, to apply for an ITIN, or Form SS-4, Application for Employer Identification Number, to apply for an EIN. You can apply for an EIN online by accessing the IRS website at [www.irs.gov/businesses](http://www.irs.gov/businesses) and clicking on Employer Identification Number (EIN) under Starting a Business. You can get Forms W-7 and SS-4 from the IRS by visiting [IRS.gov](http://IRS.gov) or by calling 1-800-TAX-FORM (1-800-829-3676).

If you are asked to complete Form W-9 but do not have a TIN, write "Applied For" in the space for the TIN, sign and date the form, and give it to the requester. For interest and dividend payments, and certain payments made with respect to readily tradable instruments, generally you will have 60 days to get a TIN and give it to the requester before you are subject to backup withholding on payments. The 60-day rule does not apply to other types of payments. You will be subject to backup withholding on all such payments until you provide your TIN to the requester.

**Note.** Entering "Applied For" means that you have already applied for a TIN or that you intend to apply for one soon.

**Caution:** A disregarded domestic entity that has a foreign owner must use the appropriate Form W-8.

**Part II. Certification**

To establish to the withholding agent that you are a U.S. person, or resident alien, sign Form W-9. You may be requested to sign by the withholding agent even if item 1, below, and items 4 and 5 on page 4 indicate otherwise.

For a joint account, only the person whose TIN is shown in Part I should sign (when required). In the case of a disregarded entity, the person identified on the "Name" line must sign. Exempt payees, see *Exempt Payee* on page 3.

**Signature requirements.** Complete the certification as indicated in items 1 through 3, below, and items 4 and 5 on page 4.

**1. Interest, dividend, and barter exchange accounts opened before 1984 and broker accounts considered active during 1983.** You must give your correct TIN, but you do not have to sign the certification.

**2. Interest, dividend, broker, and barter exchange accounts opened after 1983 and broker accounts considered inactive during 1983.** You must sign the certification or backup withholding will apply. If you are subject to backup withholding and you are merely providing your correct TIN to the requester, you must cross out item 2 in the certification before signing the form.

**3. Real estate transactions.** You must sign the certification. You may cross out item 2 of the certification.

**4. Other payments.** You must give your correct TIN, but you do not have to sign the certification unless you have been notified that you have previously given an incorrect TIN. "Other payments" include payments made in the course of the requester's trade or business for rents, royalties, goods (other than bills for merchandise), medical and health care services (including payments to corporations), payments to a nonemployee for services, payments to certain fishing boat crew members and fishermen, and gross proceeds paid to attorneys (including payments to corporations).

**5. Mortgage interest paid by you, acquisition or abandonment of secured property, cancellation of debt, qualified tuition program payments (under section 529), IRA, Coverdell ESA, Archer MSA or HSA contributions or distributions, and pension distributions.** You must give your correct TIN, but you do not have to sign the certification.

**Note.** If no name is circled when more than one name is listed, the number will be considered to be that of the first name listed.

**Secure Your Tax Records from Identity Theft**

Identity theft occurs when someone uses your personal information such as your name, social security number (SSN), or other identifying information, without your permission, to commit fraud or other crimes. An identity thief may use your SSN to get a job or may file a tax return using your SSN to receive a refund.

To reduce your risk:

- Protect your SSN,
- Ensure your employer is protecting your SSN, and
- Be careful when choosing a tax preparer.

If your tax records are affected by identity theft and you receive a notice from the IRS, respond right away to the name and phone number printed on the IRS notice or letter.

If your tax records are not currently affected by identity theft but you think you are at risk due to a lost or stolen purse or wallet, questionable credit card activity or credit report, contact the IRS Identity Theft Hotline at 1-800-908-4490 or submit Form 14039.

For more information, see Publication 4535, Identity Theft Prevention and Victim Assistance.

Victims of identity theft who are experiencing economic harm or a system problem, or are seeking help in resolving tax problems that have not been resolved through normal channels, may be eligible for Taxpayer Advocate Service (TAS) assistance. You can reach TAS by calling the TAS toll-free case intake line at 1-877-777-4778 or TTY/TDD 1-800-829-4059.

**Protect yourself from suspicious emails or phishing schemes.**

Phishing is the creation and use of email and websites designed to mimic legitimate business emails and websites. The most common act is sending an email to a user falsely claiming to be an established legitimate enterprise in an attempt to scam the user into surrendering private information that will be used for identity theft.

The IRS does not initiate contacts with taxpayers via emails. Also, the IRS does not request personal detailed information through email or ask taxpayers for the PIN numbers, passwords, or similar secret access information for their credit card, bank, or other financial accounts.

If you receive an unsolicited email claiming to be from the IRS, forward this message to [phishing@irs.gov](mailto:phishing@irs.gov). You may also report misuse of the IRS name, logo, or other IRS property to the Treasury Inspector General for Tax Administration at 1-800-366-4484. You can forward suspicious emails to the Federal Trade Commission at: [spam@uce.gov](mailto:spam@uce.gov) or contact them at [www.ftc.gov/idtheft](http://www.ftc.gov/idtheft) or 1-877-IDTHEFT (1-877-438-4338).

Visit [IRS.gov](http://IRS.gov) to learn more about identity theft and how to reduce your risk.

**What Name and Number To Give the Requester**

For this type of account:	Give name and SSN of:
1. Individual	The individual
2. Two or more individuals (joint account)	The actual owner of the account or, if combined funds, the first individual on the account <sup>1</sup>
3. Custodian account of a minor (Uniform Gift to Minors Act)	The minor <sup>2</sup>
4. a. The usual revocable savings trust (grantor is also trustee) b. So-called trust account that is not a legal or valid trust under state law	The grantor-trustee <sup>1</sup>  The actual owner <sup>1</sup>
5. Sole proprietorship or disregarded entity owned by an individual	The owner <sup>3</sup>
6. Grantor trust filing under Optional Form 1099 Filing Method 1 (see Regulation section 1.671-4(b)(2)(i)(A))	The grantor <sup>4</sup>
For this type of account:	Give name and EIN of:
7. Disregarded entity not owned by an individual	The owner
8. A valid trust, estate, or pension trust	Legal entity <sup>4</sup>
9. Corporation or LLC electing corporate status on Form 8832 or Form 2553	The corporation
10. Association, club, religious, charitable, educational, or other tax-exempt organization	The organization
11. Partnership or multi-member LLC	The partnership
12. A broker or registered nominee	The broker or nominee
13. Account with the Department of Agriculture in the name of a public entity (such as a state or local government, school district, or prison) that receives agricultural program payments	The public entity
14. Grantor trust filing under the Form 1041 Filing Method or the Optional Form 1099 Filing Method 2 (see Regulation section 1.671-4(b)(2)(i)(B))	The trust

<sup>1</sup> List first and circle the name of the person whose number you furnish. If only one person on a joint account has an SSN, that person's number must be furnished.

<sup>2</sup> Circle the minor's name and furnish the minor's SSN.

<sup>3</sup> You must show your individual name and you may also enter your business or "DBA" name on the "Business name/disregarded entity" name line. You may use either your SSN or EIN (if you have one), but the IRS encourages you to use your SSN.

<sup>4</sup> List first and circle the name of the trust, estate, or pension trust. (Do not furnish the TIN of the personal representative or trustee unless the legal entity itself is not designated in the account title.) Also see *Special rules for partnerships* on page 1.

\*Note. Grantor also must provide a Form W-9 to trustee of trust.

**Privacy Act Notice**

Section 6109 of the Internal Revenue Code requires you to provide your correct TIN to persons (including federal agencies) who are required to file information returns with the IRS to report interest, dividends, or certain other income paid to you; mortgage interest you paid; the acquisition or abandonment of secured property; the cancellation of debt; or contributions you made to an IRA, Archer MSA, or HSA. The person collecting this form uses the information on the form to file information returns with the IRS, reporting the above information. Routine uses of this information include giving it to the Department of Justice for civil and criminal litigation and to cities, states, the District of Columbia, and U.S. possessions for use in administering their laws. The information also may be disclosed to other countries under a treaty, to federal and state agencies to enforce civil and criminal laws, or to federal law enforcement and intelligence agencies to combat terrorism. You must provide your TIN whether or not you are required to file a tax return. Under section 3406, payers must generally withhold a percentage of taxable interest, dividend, and certain other payments to a payee who does not give a TIN to the payer. Certain penalties may also apply for providing false or fraudulent information.

**LEGAL NOTICE**

**INVITATION TO BIDDERS**

Sealed Bids will be received in the Office of Gilbert D. Jalomo, Jr., County Purchasing Agent, Fort Bend County, Travis Annex, 301 Jackson, Suite 201, Richmond, TX 77469 for the following until **THURSDAY, MAY 17, 2012 at 1:30 P.M.** (CST). All bids will then be publicly opened and read in the Office of the Purchasing Agent, Travis Annex, 301 Jackson, Suite 201, Richmond, TX 77469. Bids received after the specified time will be returned unopened. Solicitation is available on the Purchasing Agent's website located at [www.co.fort-bend.tx.us](http://www.co.fort-bend.tx.us). All addendums will be posted on Purchasing Agent's website.

**BID 12-052 – WHEELCHAIR ACCESSIBLE MINIVAN**

Unit pricing is required; payment will be by check after products/services are rendered. No bonds are required.

Fort Bend County reserves the right to reject any or all bids.

Signed:

Gilbert D. Jalomo, Jr., Purchasing Agent

Fort Bend County, Richmond, Texas



Filename: 12-052.doc  
Directory: I:\BID\Legals for Newspaper\2012 Legals  
Template: C:\Documents and  
Settings\kaminskd\FORTBEND\Application  
Data\Microsoft\Templates\Normal.dot  
Title: INVITATION TO BIDDERS  
Subject:  
Author: kaminskd  
Keywords:  
Comments:  
Creation Date: 4/28/2012 11:51:00 PM  
Change Number: 3  
Last Saved On: 4/28/2012 11:54:00 PM  
Last Saved By: kaminskd  
Total Editing Time: 2 Minutes  
Last Printed On: 4/28/2012 11:54:00 PM  
As of Last Complete Printing  
Number of Pages: 1  
Number of Words: 160 (approx.)  
Number of Characters: 870 (approx.)

A handwritten signature or set of initials, possibly 'DL', located in the bottom right corner of the page.