

LEASE AGREEMENT

THIS AGREEMENT made this day by and between **FORT BEND COUNTY**, a body corporate and politic under the laws of the State of Texas, by and through its Commissioners Court, hereinafter referred to as "Lessor," and **CLEAR WIRELESS LLC, a Nevada Limited Liability Company**, authorized to do business in the State of Texas, hereinafter referred to as "Lessee."

WHEREAS, the Lessor is the owner of real property and improvements located in Fort Bend County, Texas, and further described in Exhibit A, attached hereto and made a part hereof for all purposes, hereinafter referred to as "Lease Premises;" and,

WHEREAS, Lessee desires to lease a portion of the Lease Premises for the purpose of operation, installation and maintenance of certain cellular telephone antenna and related equipment, along with restricted ingress and egress thereto, and utility and cable easements thereto; and,

WHEREAS, Lessor represents that such lease of County property is authorized pursuant to RFP 09-107.

NOW THEREFORE, in consideration of the terms, conditions and rentals hereinafter set forth, Lessor and Lessee agree to the following:

WITNESSETH, THAT

**1.
USE**

The Lease Premises are hereby leased to Lessee as a site for a wireless communications facility and for any other lawful purpose, consistent with related applications, for which Lessee may desire to use the Leased Premises. Lessee shall have the right to erect, construct, operate, maintain, repair and replace on the Leased Premises the equipment described in Exhibit A – Product Specifications. Within the confines of the equipment footprint, Lessee shall have the right to erect, construct, operate, maintain, repair and replace on the Leased Premises the equipment described in Exhibit A. Lessee agrees and shall be required to light the communications monopole or tower, if any, in the manner required by the Federal Aviation Agency for structures 200' or higher. **Only the items listed in Exhibit A are allowable on the Leased Premises. Any additional structures, antennae, footprints, equipment, cabinets of any kind, and/or any other items not specifically contained in Exhibit A and authorized by Lessor are strictly prohibited. Lessee's failure to comply with the requirements of this paragraph shall constitute a default of this agreement and call for the immediate cancellation and termination of this**

agreement. Lessor shall have the right and authority to remove any and all structures, antennae, footprints, cabinets of any kind, or any other item placed/installed on the Leased Premises without notice to Lessee, in the event of a breach of this paragraph. Lessor shall not be responsible for any damage to any structures, antennae, footprints, equipment, cabinets of any kind, and/or any other item removed from the Leased Premises in the event of Lessee's default. Notwithstanding the foregoing, Lessee shall have the right to cure any default as provided under paragraph 8(b) of this Agreement.

Lessee is hereby granted the limited right of ingress and egress to the Lease Premises during normal business hours of Lessor for the purpose of installation, maintenance, repair, replacement and removal of the communications tower and other equipment. Lessee shall have limited access to the Leased Premises at times when the Lessor's business activity is closed, such as after 5:00 p.m., weekends and holidays. In the event Lessee requires access to the Leased Premises after hours, Lessee shall contact Lessor no less than four (4) hours prior to being granted access to the Leased Premises.

Subject to the provisions of Paragraph 13 hereof, any and all structures, improvements, equipment, facilities and other property of whatever kind installed by or for Lessee on the Leased Premises shall be and remain the property of Lessee, whether affixed to the realty or not, and Lessee shall have the right to remove the same at any time during the term hereof and within 90 days after the termination or expiration of this lease or any extensions or renewals thereof. All the while, rent shall continue to be paid to Lessor until the removal of the property.

Lessee agrees and understands that it is the Lessee's responsibility to abide by all federal, state and local rules and regulations pertaining to the operation of the site and of Lessee's equipment; including without limitations, those pertaining to the installation, maintenance, height, location, use, operation, and removal of its equipment, antenna systems, and any other alterations or improvements authorized herein. Lessee agrees and understands that changes in rules and policies by agencies or persons other than Lessor that affect the operation or use of Lessee's equipment and of the site are not Lessor's responsibility. Lessee hereby represents that Lessee has obtained the necessary licenses and permits required to use said site, or that Lessee will obtain said licenses or permits, at Lessee's own expense, prior to any such use.

Lessee represents that it has independently ascertained that the site it adequate and proper for Lessee's intended use and has entered into this Lease Agreement based solely upon said independent investigation, and not by any representation by Lessor.

2.
TERM

This Lease Agreement shall be for a primary term ("Primary Term") of one (1) year, commencing on the date executed by the Lessee or Lessor, whichever is later the ("Commencement Date") and ending on the first anniversary of that date; provided, however, Lessee shall have the right and option to extend the term of this Lease Agreement for four (4) additional one (1) year periods, commencing on the first (1st) anniversary date of this lease (the "Renewal Period") with a three percent (3%) annual increase for each renewal. In no event shall this Lease agreement extend past December 31, 2017. Lessor shall have the right to terminate this Lease Agreement by providing Lessee ninety (90) days written notice prior to any anniversary date.

3.
UTILITIES

If the Leased Premises is metered for electrical energy and power furnished by an electric utility serving the area, Lessee shall have the right to, at Lessee's sole cost and expense, install or transfer an electric meter to the Leased Premises, to Lessee's name and account. Lessee agrees to pay any and all power bills and/or any other obligations which it incurs in connection with the Leased Premises during the entire term of this lease and any renewal thereof, and agrees to hold the Lessor harmless from same. If the Leased Premises is not metered for electric energy and power furnished by an electric utility, Lessor hereby grants unto Lessee an easement for the purpose of bringing electricity to the Leased Premises. Telephone and electric service lines shall be installed by Lessee.

4.
COMPLIANCE WITH LAWS

Lessee agrees, at its expense, to conduct all operations on said Leased Premises in full compliance with all laws, ordinances, rules, regulations, orders or directives of any government authority, and shall not commit or allow to be committed any public or private nuisance thereon.

5.
WARRANTY

Lessor warrants that Lessor owns fee simple title to the Leased Premises, or has the authority to assign or sublet a previously executed lease, and that the leasehold estate herein created is and shall be free and clear of all liens and other encumbrances. Lessor warrants that this agreement includes access to the Leased Premises.

6.
COVERAGE AND INTERFERENCE

Lessor makes no representations concerning the distance at which useable signals may be transmitted and received from the site or location thereof. Lessee is hereby notified that the site is subject to degradation performance from, but not limited to, natural and man-made phenomena such as so-called "skip" interference, power line and ignition noise, intermodulation, co-channel interference, and interference from users of the same or other radio frequencies. Lessor is not responsible for interference due to the above or other causes.

7.
RENTAL

As rent and rental for the use of the Leased Premises, Lessee shall pay to Lessor the annual sum of **\$15,913.50**, payable in advance on or before February 15, 2012. This rental rate will be increased annually effective on the anniversary of the Commencement Date each year by three (3%) as follows:

Year 1 (2012 to 2013)	\$ 15,913.50
Year 2 (2013 to 2014)	\$ 16,390.91
Year 3 (2014 to 2015)	\$ 16,882.63
Year 4 (2015 to 2016)	\$ 17,389.11
Year 5 (2016 to 2017)	\$ 17,910.78

Each renewal period shall automatically commence immediately upon the expiration of the prior term or renewal period, unless Tenant provides at least thirty (30) days prior written notice to Landlord of its intent not to exercise the renewal period. All future rental payments due hereunder shall be paid or tendered to Lessor at Lessor's address specified herein, or to such other place as Lessor may from time to time designate the Lessee on or before February 15 for each year Lessee seeks to renew this Lease Agreement. No change of ownership with respect to the Leased Premises or with respect to the rental payments provided for herein shall be effective and binding upon Lessee for any purpose until thirty (30) days after the acquiring party shall have furnished Lessee by registered United States Mail, a copy duly certified by the appropriate public official, of the recorded instrument, if any.

Failure on the part of Lessee to make any rental payment hereunder on or before its due date shall give Lessor the right (following written notice and an opportunity to cure as provided below) to declare a forfeiture of this lease, which declaration of forfeiture shall be made in writing and shall be mailed or delivered

to Lessee at the address specified herein (or to any subsequent address hereafter specified by Lessee). This lease and all rights of Lessee hereunder shall terminate thirty (30) days after receipt by Lessee of such written declaration of forfeiture, unless on or before the expiration of such thirty (30) day period the Lessee shall pay to Lessor the rental then owing hereunder.

**8.
TERMINATION**

- A)** Lessee may terminate this lease at any time by giving thirty (30) days written notice to Lessor of its intention to do so, after the expiration of the Primary Term.
- B)** Lessor may terminate this lease if Lessee shall default in the payment of any rent or fails to comply with the material provisions or conditions of this lease, and in either event, if such default shall continue for a period of thirty (30) days after written notice given by Lessor to Lessee specifying such default.
- C)** Lessor may terminate this lease at any time by giving ninety (90) days written notice to Lessee.
- D)** Rent shall continue until all personal property of the Lessee is removed and any damages repaired.
- E)** Lessor may terminate this lease if at any time Environmental Hazards are caused by Lessee's activities.

**9.
INSPECTION AND ACCESS**

Lessor shall be afforded unlimited access to the site and/or to Lessee's equipment for inspection purposes and Lessee shall furnish Lessor with a key or the combination of any lock securing the site and/or Lessee's equipment.

**10.
ASSIGNABILITY**

Lessee shall not sublet the Leased Premises without prior written consent of Lessor. Upon acceptance of any assignment of this lease (together with a copy of such assignee's written assumption of Lessee's obligations hereunder), Lessor shall look solely to such assignee for the satisfaction of Lessee's obligations hereunder, and Lessee shall be released from any further obligations under this lease.

Lessee may lease a portion of the communication transmission facility without consent of Lessor. However, any lease of a portion of the communication transmission facility shall not release Lessee from any of the Lessee's obligations hereunder. Lessee agrees and shall demand the Insurance and Indemnity

provisions of Paragraph 14 from any and all parties to whom a portion of the communication transmissions facility is leased from Lessee.

11.
ACCEPTABLE ENCUMBRANCES

Notwithstanding the terms and provisions of Paragraph 5 hereof, this lease is made expressly subject to certain valid and existing easements, leases, rights of way, oil, gas and mineral rights, and restrictions which are presently of record.

12.
DEFAULT

If Lessee fails to comply with any material provisions of this Lease Agreement and such failure is not cured within thirty (30) days after receipt of written notice thereof from Lessor, Lessor may, at its option, terminate this Lease Agreement without affecting any rights to which Lessor may be entitled. If any such default cannot reasonably be cured within thirty (30) days, Lessee will not be deemed to be in default hereunder if Lessee commences curing such default within the thirty (30) day period and thereafter diligently pursues such cure to completion. However, in no event shall any default remain uncured for a period of sixty (60) days.

If Lessor fails to comply with any material provisions of this Lease Agreement and such failure is not cured within thirty (30) days after receipt of written notice thereof from Lessee, Lessee may, at its option, terminate this Lease Agreement without affecting any rights to which Lessor may be entitled. If any such default cannot reasonably be cured within thirty (30) days, Lessee will not be deemed in default hereunder if Lessor commences curing such default within the thirty (30) day period and thereafter diligently pursues such cure to completion.

13.
REMOVAL OF PROPERTY

Lessee shall have the right at any time during or within ninety (90) days after the termination of this lease to dismantle and remove all property and improvements placed by Lessee on the Leased Premises or on the lands of Lessor adjacent and contiguous to the Leased Premises, regardless of the manner in which such property and improvements may be affixed thereto; provided, however, that said premises shall be restored to substantially their original condition insofar as it is reasonably practicable to do so, reasonable wear and tear excepted, or, if mutually agreed upon, it may transfer such property to Lessor and leave the same in place as abandoned property. Lessee is required to repair any damage to the Leased Premises upon termination of this

Agreement. Lessee shall be responsible and held liable for any and all Environmental Hazards caused by Lessee's activities and shall remove any and all such Environmental Hazards to Lessor's satisfaction.

This lease shall be binding upon and inure to the benefit of the parties hereto and their respective heirs, successors, assigns and legal representatives (where assignment is allowed). This agreement may be executed in counterparts, each of which shall be considered an original of this instrument, and all of which shall constitute one and the same instrument. This agreement may be ratified by separate instruments referring hereto and shall be binding upon each party who executes or ratifies it without regard to whether it is executed or ratified by all those named herein as Lessor or Lessee, or whether such executing or ratifying party is named herein as a lessor or lessee.

14. INSURANCE AND INDEMNITY

Lessor provides no insurance on Lessee's equipment. Lessee agrees to furnish Lessor with Certificates of Insurance certifying that Lessee has agreed to the below specified insurance. Further, such Certificate of Insurance will name Lessor as an additional named insured on liability insurance with minimum coverage of:

Bodily Injury and/or Death: \$500,000.00 for injury or death to any one person, and \$1,000,000.00 for all injuries and/or death by more than one person in any one occurrence; and

Property Damage: \$1,000,000.00 for damage as a result of any one accident.

Except as to injury, death or property damage resulting from the sole negligence of Lessor, Lessor's agents, employees or contractors, Lessee agrees to indemnify and hold harmless Lessor and its representatives, successors and assigns from and against all claims, demands, rights, costs, expenses, compensation and causes of action of whatever kind and nature, including bodily and personal injuries, damage to property and the consequences thereof, resulting from the use, installation, removal, maintenance or repair of Lessee's equipment or Lessee's employees, officers, directors, agents, owners, representatives, contractors, guest, invitees, workers, employees, successors and assigns. Lessee hereby acknowledges and agrees that Lessee's use of the Site is at Lessee's own risk, and Lessee hereby releases Lessor, Lessor's agents, employees and contractors from all claims except for any damage or injury resulting from the sole negligence or intentional wrongful conduct of Lessor, Lessor's agents, employees or contractors.

15.
HAZARDOUS MATERIALS

Lessee represents to Lessor, as part of the consideration recited herein that no part of the leased premises shall be used by Lessee for disposal, storage, treatment, processing, manufacturing or other handling of any hazardous wastes, hazardous substances, asbestos or other materials (collectively, the foregoing are referred to herein as "Hazardous Materials") deemed hazardous or otherwise subject to any federal, state, county or municipal laws, statutes, codes, rules, regulations or ordinances pertaining to the use, handling, release, disposal, storage, treatment, processing or manufacturing of such Hazardous Materials or similar materials and substances (collectively, all such laws, etc. are referred to herein as "Environmental Laws.")

Lessee expressly acknowledges and agrees that in the event of any such contamination by Hazardous Materials shall hereafter occur, or shall hereafter be determined to have occurred, arising out of or resulting from Lessee's occupancy, at, upon, or from the leased premises, such occurrence of contamination shall be deemed, at Lessor's option, to constitute a default under this Lease Agreement. Lessee hereby covenants and agrees, further, that in the event of the occurrence of any such contamination by Hazardous Materials arising from Lessee's occupancy of the leased premises, or in the event of the determination that any such contamination of the property has occurred, Lessee shall be obligated, whether or not required by law, immediately to clean-up, remove, resolve, minimize the impact of or otherwise to remediate (any and all such activities being referred to generally as "Remediation") any such contamination of the property.

Lessee shall indemnify Lessor for, and shall defend and hold Lessor harmless from and against, any and all liabilities, causes of action, demands, penalties, losses, costs and expenses, including, but not limited to, attorney's fees and costs of Remediation, which may be suffered, paid or incurred by Lessor with respect to, or as a direct or indirect result of, the presence on or under, of the escape, seepage, leakage, spillage, discharge, emissions or release upon or from the leased premises of any Hazardous Materials or any contamination by Hazardous Materials, that may arise out off or result from the Lessee's use and occupancy of the leased premises.

16.
DEBT SECURITY

Lessee may, without Lessor's consent, pledge, mortgage, convey by deed of trust or security deed, assign, create a security interest in, or otherwise execute and deliver any and all instruments for the purpose of securing a bona fide indebtedness, any or all of Lessee's interest in this Lease, any part thereof,

and any and all of Lessee's right, title and interest in and to any and all of the Leased Premises. Promptly on Lessee's or Lessee's lender's request, Lessor shall execute and deliver all documents requested and prepared by any of Lessee's lenders including but not limited to waivers of Lessor's right to levy or distraint upon for rent of any of Lessee's property given as security for a debt, Lessor's estoppel certificate and agreement, consents to giving notice to Lessee's lender(s) in the event of Lessee's default under the provisions of this Lease, consents to Lessee's assignment to any lender(s) of any and all of Lessee's interest in or to this Lease and the Leased Premises and nondisturbance agreements from Lessor.

**17.
NOTICES**

All notices pertaining to this lease shall be considered as duly delivered when mailed to the address hereafter specified by registered, certified or regular mail. All notices shall be considered as duly delivered when mailed to the addresses specified below as hereinafter indicated. Either party may from time to time designate a different address by written notice to the other party. The initial addresses to be utilized hereunder are as follows, to-wit:

Lessor: Fort Bend County
301 Jackson, Suite 719
Richmond, Texas 77471

Copy to: Fort Bend County Purchasing Agent
301 Jackson
Richmond, Texas 77469

Lessee: Clear Wireless LLC
Attn: Site Leasing
4400 Carillon Point
Kirkland, WA 98033
Telephone: (425)-216-7600
Fax: (425)-216-7900
Email: siteleasing@clearwire.com

Copy to: Clear Wireless LLC
Attn: Legal Department
4400 Carillon Point
Kirkland, WA 98033
Telephone: (425)-216-7600
Fax: (425)-216-7900

18.
INDEMNIFICATION

Lessee shall indemnify and hold harmless Lessor from and against any and all claims, suits, causes of action and damages of any kind or nature, arising from, or relating to the use of the site by Lessee unless such claim or damage is the result of the act, omission or negligence of Lessor. IN NO EVENT WILL EITHER PARTY HERETO BE LIABLE FOR ANY LOSS OF USE, LOSS OF TIME, INCONVENIENCE, COMMERCIAL LOSS, LOST PROFITS OR SAVINGS OR OTHER INCIDENTAL OR CONSEQUENTIAL DAMAGES TO THE FULLEST EXTENT SUCH MAY BE DISCLAIMED BY LAW.

19.
ENVIRONMENTAL

To the best of Lessor's knowledge, the Lessor represents and warrants that the site has not been used for the generation, storage, treatment or disposal of hazardous substances or hazardous wastes. In addition, no hazardous substances, hazardous wastes, pollutants, asbestos, polychlorinated biphenyls (PCBs), petroleum or other fuels (including crude oil or any fraction or derivative thereof) or underground storage tanks (collectively "Environmental Hazards") are located on or about the site. For purposes of this lease, the term "hazardous substances" shall be defined as in the Comprehensive Environmental Response, Compensation, and Liability Act (42 U.S.C. Section 9601 *et seq.*) (CERCLA), and any regulations promulgated pursuant thereto. The term "hazardous wastes" shall be as defined in the Resource Conservation and Recovery Act (42 U.S.C. Section 6901 *et seq.*) (RCRA), and any regulations promulgated pursuant thereto. The term "pollutants" shall be as defined in the Clean Water Act (33 U.S.C. Section 1251 *et seq.*), and any other regulations promulgated pursuant thereto. Lessee shall have the right and obligation during the Option Period to conduct such environmental tests as Lessee shall require to determine if Environmental Hazards exist on or about the site. Lessor shall have no obligation to conduct such test nor does Lessor have any obligation to indemnify and save harmless Lessee from and against any liabilities, penalties, fines, forfeitures, demands, damages, losses, claims, causes of action, suits, judgments, and costs and expenses, incidental thereto with any respect to any Environmental Hazards. In the event any Environmental Hazards are found during the Option Period, Lessee shall have the right to terminate such option and receive the monies deposited to Lessor. If any Environmental Hazards are found at any time during the Lease Period, other than any Environmental Hazards caused by Lessee's activities, Lessee shall have the right to terminate this lease by so notifying Lessor in writing. Obligations of Lessee upon termination shall be the same as to Lessee's obligations as previously set out in this lease.

20.
ESTOPPEL

Lessee shall at any time upon ten (10) days prior written notice from Lessor execute, acknowledge and deliver to Lessor a statement in writing (a) certifying that this Lease Agreement is unmodified and in full force and effect (or, if modified, stating the nature of such modification), and the date to which the Rent and other charges are paid in advance, if any, (b) acknowledging that there are not, to Lessee's knowledge, any uncured defaults on the part of Lessor hereunder, or specifying such defaults if any are unclaimed, and (c) setting forth any prepaid Rent. Any such statement may be conclusively relied upon by any prospective purchaser, investor, lessee or encumbrancer of the Site.

21.
MISCELLANEOUS

- (a) Lessor and Lessee represent and warrant to each other that no broker was involved in connection with this transaction.
- (b) This lease shall be construed and governed by the laws of the State of Texas. The parties agree that venue for any action involving this lease may only be brought in Fort Bend County.
- (c) This agreement may be amended only in writing, executed by both parties hereto or their permitted transferees.
- (d) This lease, together with any exhibits attached hereto, shall constitute the entire agreement between the parties hereto. No party shall be bound by any communications between them on the subject matter of this lease unless the communication is in writing, bears a date contemporaneous with or subsequent to the date of this lease, and is agreed to by all parties hereto. Upon execution of this lease, all prior agreements or understandings between the parties regarding the subject matter hereof shall be null and void.
- (e) In the event of one or more of the provisions contained in this Agreement shall for any reason be held to be invalid, illegal or unenforceable in any respect, such invalidity, illegality, or unenforceability shall not affect any other provision hereof and this agreement shall be construed as if such invalid, illegal, or unenforceable provision had never been contained herein.
- (f) The headings of the paragraphs of this lease are for the guidance and convenience of reference only and shall not otherwise affect any of the terms or provisions hereof.
- (g) This Lease Agreement may be executed in any number of counterparts, each of which shall be deemed an original instrument, and all of which together shall constitute one and the same instrument. This Lease agreement shall become operative when each party has executed at least one counterpart.

- (h) This Agreement contains the entire Agreement among the parties and supercedes all other negotiations and agreements, whether written or oral.

**22.
EXECUTION**

IN TESTIMONY OF WHICH, THIS AGREEMENT has been executed by Lessor and Lessee as of the date below stated. Lessor and Lessee warrant and represents that the individual executing this agreement on behalf each have full authority to execute this Agreement and bind each party to the same.

LESSOR:

FORT BEND COUNTY

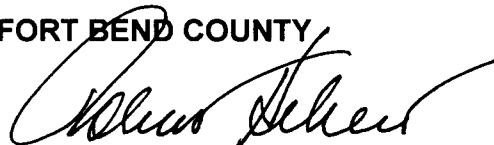
By: 
Robert E. Hebert, County Judge

ATTEST:

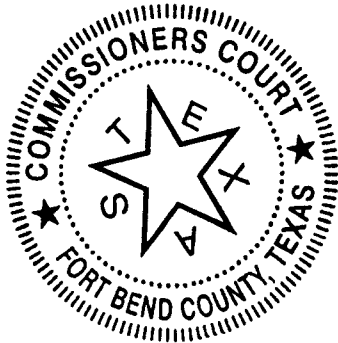

Dianne Wilson, County Clerk

Date: 2-28-2012



LESSEE:

CLEAR WIRELESS LLC

By: 
Signature

Printed Name: _____

Jason Caliente
Title: Director - Network Deployment

Date: 2/13/12

ATTEST:

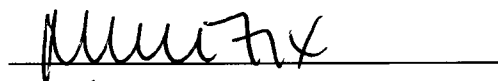
Michelle Fox

mer: Clear Wireless Roof Lease.3892(2012)

Exhibit A

Clear Wireless, LLC

TX-HOU0465A

SITE ADDRESS:
309 S. 4TH STREET
HOUSTON, TX 77002

DRAWING INDEX	REV.
T-1	TITLE SHEET
A-1	ROOF PLAN
A-2	ELEVATIONS
A-3	DETAILS AND NOTES
A-4	STRUCTURAL NOTES, SECTIONS AND DETAILS
A-5	EQUIPMENT CLIF SHEETS
A-6	CABINET DETAILS
E-1	PROPOSED UTILITY ROUTING PLAN
E-2	ELECTRICAL DETAILS
E-3	ELECTRICAL DETAILS
E-4	ELECTRICAL NOTES

NOTES:

1. ALL WORK SHALL BE IN ACCORDANCE WITH THE LATEST EDITIONS OF THE INTERNATIONAL BUILDING CODES AND ALL APPLICABLE LOCAL ORDINANCES. THE CONTRACTOR SHALL BE RESPONSIBLE FOR OBTAINING ALL NECESSARY PERMITS AND APPROVALS FROM THE APPROPRIATE AGENCIES. THE CONTRACTOR SHALL BE RESPONSIBLE FOR OBTAINING ALL NECESSARY PERMITS AND APPROVALS FROM THE APPROPRIATE AGENCIES. THE CONTRACTOR SHALL BE RESPONSIBLE FOR OBTAINING ALL NECESSARY PERMITS AND APPROVALS FROM THE APPROPRIATE AGENCIES.

DIRECTIONS:
THIS CONTRACT IS SUBJECT TO THE CLEAR WIRELESS, LLC STANDARD TERMS AND CONDITIONS OF SERVICE, WHICH ARE AVAILABLE AT WWW.CLEARWIRELESS.COM. THE CONTRACTOR SHALL BE RESPONSIBLE FOR OBTAINING ALL NECESSARY PERMITS AND APPROVALS FROM THE APPROPRIATE AGENCIES. THE CONTRACTOR SHALL BE RESPONSIBLE FOR OBTAINING ALL NECESSARY PERMITS AND APPROVALS FROM THE APPROPRIATE AGENCIES.

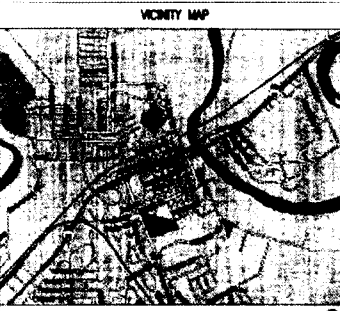

SCALE: 1"=2000'

APPROVAL

ARCHITECT	DATE	TIME
ENGINEER	DATE	TIME
PLUMBER	DATE	TIME
ELECTRICIAN	DATE	TIME
MECHANICAL	DATE	TIME

PROJECT SUMMARY

PROJECT NO: TX-HOU0465A
 PROJECT NAME: CLEAR WIRELESS, LLC
 PROJECT ADDRESS: 309 S. 4TH STREET, HOUSTON, TX 77002
 PROJECT CONTACT: [REDACTED]
 PROJECT PHONE: [REDACTED]
 PROJECT FAX: [REDACTED]

CLIENT: CLEAR WIRELESS, LLC
ARCHITECT: BC ARCHITECTS ENGINEERS PLLC
ENGINEER: [REDACTED]
PLUMBER: [REDACTED]
ELECTRICIAN: [REDACTED]
MECHANICAL: [REDACTED]

DATE: [REDACTED]
SCALE: 1"=2000'

BC ARCHITECTS ENGINEERS PLLC
 309 S. 4TH STREET, HOUSTON, TX 77002
 TX-HOU0465A
Clear Wireless, LLC
 309 S. 4TH STREET, HOUSTON, TX 77002

STATE OF TEXAS
 ARCHITECTS ENGINEERS
 PALL CHAMBERLAIN
 TITLE SHEET
 PROJECT NUMBER: TX-HOU0465A
 SHEET NUMBER: A-1

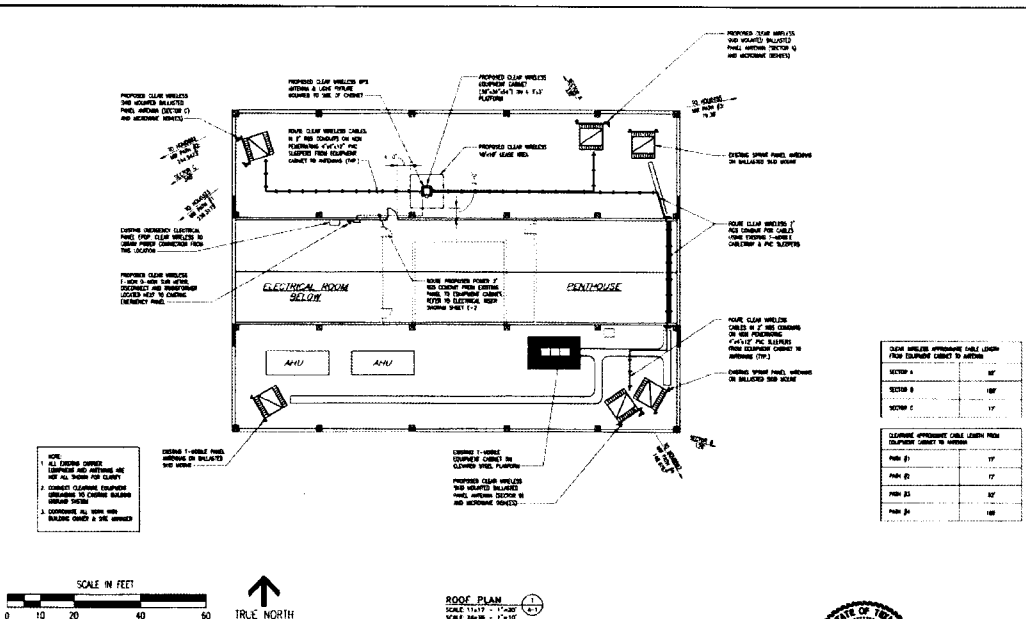

BC ARCHITECTS ENGINEERS PLLC
 309 S. 4TH STREET, HOUSTON, TX 77002
 TX-HOU0465A
Clear Wireless, LLC
 309 S. 4TH STREET, HOUSTON, TX 77002

STATE OF TEXAS
 ARCHITECTS ENGINEERS
 PALL CHAMBERLAIN
 TITLE SHEET
 PROJECT NUMBER: TX-HOU0465A
 SHEET NUMBER: A-1

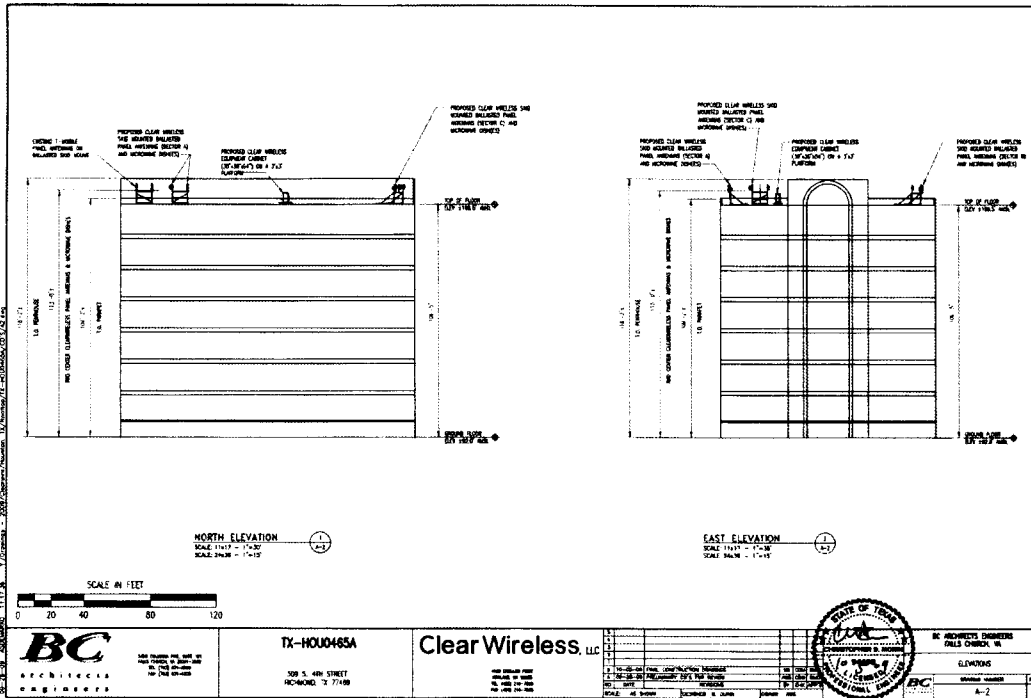

BC ARCHITECTS ENGINEERS
 TX-HOU0485A
 Clear Wireless, LLC
 308 S. 4th STREET
 HOUSTON, TX 77002

STATE OF TEXAS
 ARCHITECTS ENGINEERS
 FALLS CHURCH, VA
 ELEVATIONS
 SHEET NUMBER: A-2

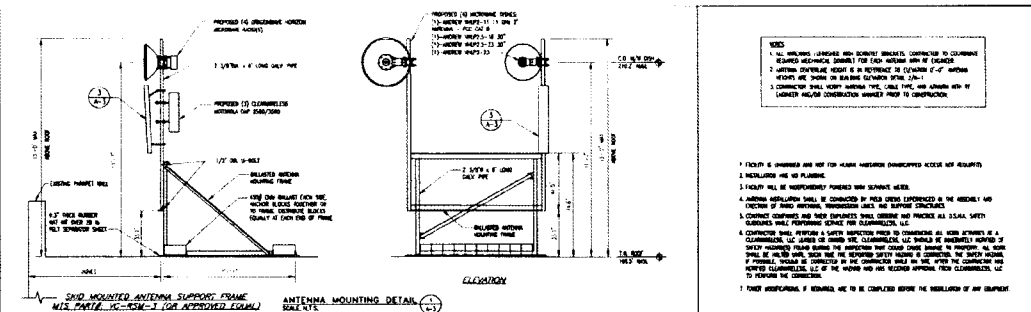

- NOTES**
1. ALL WELLS, LANTERNS AND SIGNIFY SYMBOLS CONNECTED TO CURRENT RELATED ELECTRICAL SYMBOLS FOR EACH WELLS AND IF EXCLUDED.
 2. LANTERNS CONTROL LIGHTS IS TO BE INSTALLED IN ELEVATION OF 10' HEIGHT FROM THE TOP OF THE WELLS AND SHALL BE MARKED AS SHOWN ON THE PLAN.
 3. CONSTRUCTION SHALL BE IN ACCORDANCE WITH THE LATEST EDITIONS OF THE INTERNATIONAL BUILDING CODES AND ALL OTHER APPLICABLE CODES AND REGULATIONS.
 4. CONSTRUCTION SHALL BE IN ACCORDANCE WITH THE LATEST EDITIONS OF THE INTERNATIONAL BUILDING CODES AND ALL OTHER APPLICABLE CODES AND REGULATIONS.
 5. CONSTRUCTION SHALL BE IN ACCORDANCE WITH THE LATEST EDITIONS OF THE INTERNATIONAL BUILDING CODES AND ALL OTHER APPLICABLE CODES AND REGULATIONS.
 6. CONSTRUCTION SHALL BE IN ACCORDANCE WITH THE LATEST EDITIONS OF THE INTERNATIONAL BUILDING CODES AND ALL OTHER APPLICABLE CODES AND REGULATIONS.
 7. CONSTRUCTION SHALL BE IN ACCORDANCE WITH THE LATEST EDITIONS OF THE INTERNATIONAL BUILDING CODES AND ALL OTHER APPLICABLE CODES AND REGULATIONS.
 8. CONSTRUCTION SHALL BE IN ACCORDANCE WITH THE LATEST EDITIONS OF THE INTERNATIONAL BUILDING CODES AND ALL OTHER APPLICABLE CODES AND REGULATIONS.
 9. CONSTRUCTION SHALL BE IN ACCORDANCE WITH THE LATEST EDITIONS OF THE INTERNATIONAL BUILDING CODES AND ALL OTHER APPLICABLE CODES AND REGULATIONS.
 10. CONSTRUCTION SHALL BE IN ACCORDANCE WITH THE LATEST EDITIONS OF THE INTERNATIONAL BUILDING CODES AND ALL OTHER APPLICABLE CODES AND REGULATIONS.

ANTENNA SCHEDULE

SECTION	TYPE AND MODEL	POSITION	HEIGHT	POWER LEVEL	ELECTRICAL SYMBOL	INTERNATIONAL SYMBOL	DESCRIPTION
SECTION A	ANTENNA AND WELLS AT THE TOP OF THE	-	120'	-	F	F	
SECTION B	ANTENNA AND WELLS AT THE TOP OF THE	-	120'	-	F	F	
SECTION C	ANTENNA AND WELLS AT THE TOP OF THE	-	120'	-	F	F	
PANEL NO. 3	ANTENNA AND WELLS AT THE TOP OF THE	-	120'	-	F	F	
ANTENNA 1	WELLS	WELLS	120'	-	-	-	
ANTENNA 2	WELLS	WELLS	120'	-	-	-	
ANTENNA 3	WELLS	WELLS	120'	-	-	-	
ANTENNA 4	WELLS	WELLS	120'	-	-	-	
ANTENNA 5	WELLS	WELLS	120'	-	-	-	
ANTENNA 6	WELLS	WELLS	120'	-	-	-	
ANTENNA 7	WELLS	WELLS	120'	-	-	-	
ANTENNA 8	WELLS	WELLS	120'	-	-	-	
ANTENNA 9	WELLS	WELLS	120'	-	-	-	
ANTENNA 10	WELLS	WELLS	120'	-	-	-	

ANTENNA COLOR CODING

SECTION	COLOR	DESCRIPTION
SECTION A	RED	ANTENNA AND WELLS AT THE TOP OF THE
SECTION B	BLUE	ANTENNA AND WELLS AT THE TOP OF THE
SECTION C	GREEN	ANTENNA AND WELLS AT THE TOP OF THE

BC ARCHITECTS ENGINEERS
 TX-HOU0485A
 Clear Wireless, LLC
 308 S. 4th STREET
 HOUSTON, TX 77002

STATE OF TEXAS
 ARCHITECTS ENGINEERS
 FALLS CHURCH, VA
 DETAILS AND NOTES
 SHEET NUMBER: A-3

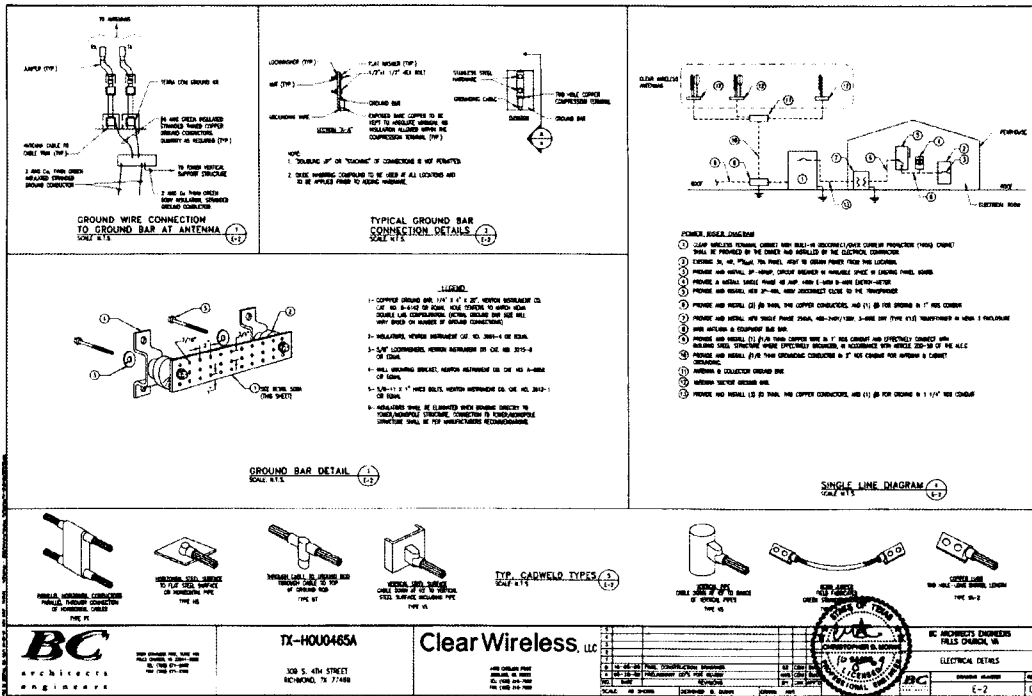

BC
architects
engineers

309 S. 4TH STREET
RICHMOND, TX 77489

TX-HOU0465A

Clear Wireless, LLC

309 S. 4TH STREET
RICHMOND, TX 77489

BC ARCHITECTS ENGINEERS
FALLS CHURCH, VA

ELECTRICAL DETAILS

DATE: 01/20/2023

SCALE: E-2

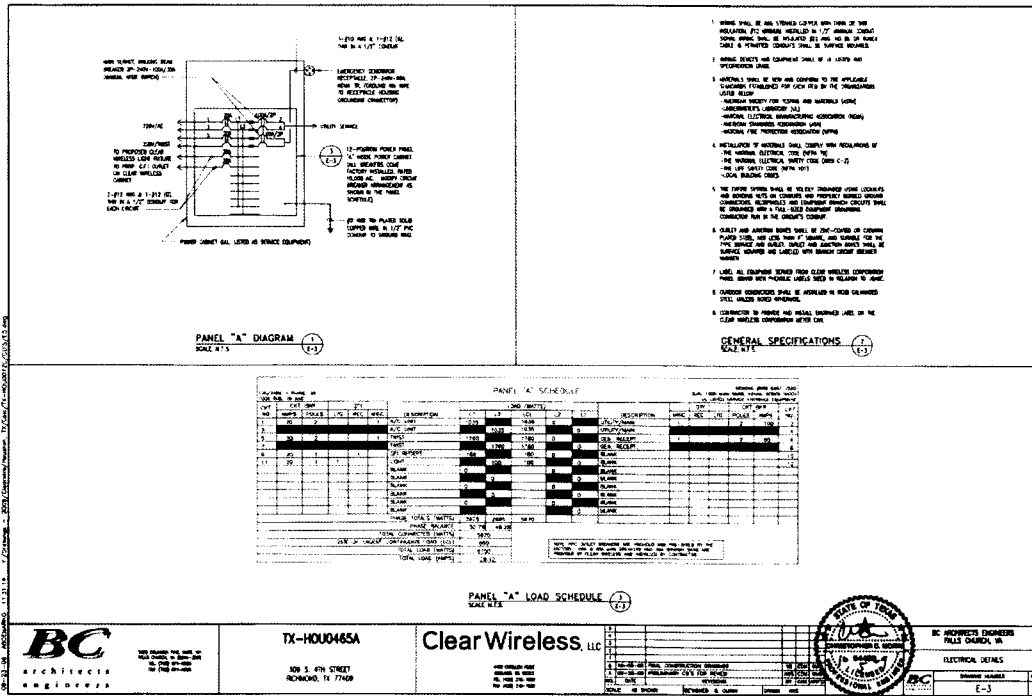

GENERAL NOTES

1. THESE NOTES AND ANY OTHER NOTES OR SPECIFICATIONS ON THE PROJECT SHALL BE READ IN FULL BEFORE COMMENCING WORK.
2. EXISTING AND PROPOSED CONDITIONS SHALL BE VERIFIED BY VISUAL INSPECTION AND SURVEY. CORRECT AND PART FOR ANY DISCREPANCIES TO BE NOTED AND CORRECTED.
3. RECORD AS-BUILT SHALL BE TO BE RELATED TO CLEARWIRELESS ARCHITECTURE.
4. PROVIDE TWO COPIES OF SPECIFICATIONS AND SUBMITTALS TO ARCHITECT AND OWNER.
5. MATERIALS AND METHODS OF CONSTRUCTION SHALL BE APPROVED BY ARCHITECT AND OWNER BEFORE COMMENCING WORK.
6. ALL WORK SHALL BE PERFORMED IN STRICT ACCORDANCE WITH ALL APPLICABLE BUILDING CODES AND LOCAL ORDINANCES. MATERIALS AND METHODS SHALL BE SUBJECT TO APPROVAL BY ARCHITECT AND OWNER.
7. CONTACT THE ARCHITECT FOR ANY AND ALL QUESTIONS REGARDING THE CONTRACT DOCUMENTS. THE ARCHITECT'S RESPONSE SHALL BE IN WRITING AND SHALL BE THE FINAL AUTHORITY FOR ALL CONTRACT DOCUMENTS.
8. PROTECT EXISTING STRUCTURES AND UTILITIES FROM DAMAGE, REMOVAL OR OBSTRUCTION. THE CONTRACTOR SHALL BE RESPONSIBLE FOR OBTAINING ALL NECESSARY PERMITS AND APPROVALS FROM ALL APPLICABLE AGENCIES.
9. THE CONTRACTOR SHALL BE RESPONSIBLE FOR OBTAINING ALL NECESSARY PERMITS AND APPROVALS FROM ALL APPLICABLE AGENCIES.
10. THE CONTRACTOR SHALL BE RESPONSIBLE FOR OBTAINING ALL NECESSARY PERMITS AND APPROVALS FROM ALL APPLICABLE AGENCIES.
11. THE CONTRACTOR SHALL BE RESPONSIBLE FOR OBTAINING ALL NECESSARY PERMITS AND APPROVALS FROM ALL APPLICABLE AGENCIES.
12. THE CONTRACTOR SHALL BE RESPONSIBLE FOR OBTAINING ALL NECESSARY PERMITS AND APPROVALS FROM ALL APPLICABLE AGENCIES.
13. THE CONTRACTOR SHALL BE RESPONSIBLE FOR OBTAINING ALL NECESSARY PERMITS AND APPROVALS FROM ALL APPLICABLE AGENCIES.
14. THE CONTRACTOR SHALL BE RESPONSIBLE FOR OBTAINING ALL NECESSARY PERMITS AND APPROVALS FROM ALL APPLICABLE AGENCIES.
15. THE CONTRACTOR SHALL BE RESPONSIBLE FOR OBTAINING ALL NECESSARY PERMITS AND APPROVALS FROM ALL APPLICABLE AGENCIES.

GENERAL SPECIFICATIONS

1. ALL WORK SHALL BE PERFORMED IN STRICT ACCORDANCE WITH ALL APPLICABLE BUILDING CODES AND LOCAL ORDINANCES.
2. MATERIALS AND METHODS OF CONSTRUCTION SHALL BE APPROVED BY ARCHITECT AND OWNER BEFORE COMMENCING WORK.
3. THE CONTRACTOR SHALL BE RESPONSIBLE FOR OBTAINING ALL NECESSARY PERMITS AND APPROVALS FROM ALL APPLICABLE AGENCIES.
4. THE CONTRACTOR SHALL BE RESPONSIBLE FOR OBTAINING ALL NECESSARY PERMITS AND APPROVALS FROM ALL APPLICABLE AGENCIES.
5. THE CONTRACTOR SHALL BE RESPONSIBLE FOR OBTAINING ALL NECESSARY PERMITS AND APPROVALS FROM ALL APPLICABLE AGENCIES.
6. THE CONTRACTOR SHALL BE RESPONSIBLE FOR OBTAINING ALL NECESSARY PERMITS AND APPROVALS FROM ALL APPLICABLE AGENCIES.
7. THE CONTRACTOR SHALL BE RESPONSIBLE FOR OBTAINING ALL NECESSARY PERMITS AND APPROVALS FROM ALL APPLICABLE AGENCIES.
8. THE CONTRACTOR SHALL BE RESPONSIBLE FOR OBTAINING ALL NECESSARY PERMITS AND APPROVALS FROM ALL APPLICABLE AGENCIES.
9. THE CONTRACTOR SHALL BE RESPONSIBLE FOR OBTAINING ALL NECESSARY PERMITS AND APPROVALS FROM ALL APPLICABLE AGENCIES.
10. THE CONTRACTOR SHALL BE RESPONSIBLE FOR OBTAINING ALL NECESSARY PERMITS AND APPROVALS FROM ALL APPLICABLE AGENCIES.
11. THE CONTRACTOR SHALL BE RESPONSIBLE FOR OBTAINING ALL NECESSARY PERMITS AND APPROVALS FROM ALL APPLICABLE AGENCIES.
12. THE CONTRACTOR SHALL BE RESPONSIBLE FOR OBTAINING ALL NECESSARY PERMITS AND APPROVALS FROM ALL APPLICABLE AGENCIES.
13. THE CONTRACTOR SHALL BE RESPONSIBLE FOR OBTAINING ALL NECESSARY PERMITS AND APPROVALS FROM ALL APPLICABLE AGENCIES.
14. THE CONTRACTOR SHALL BE RESPONSIBLE FOR OBTAINING ALL NECESSARY PERMITS AND APPROVALS FROM ALL APPLICABLE AGENCIES.
15. THE CONTRACTOR SHALL BE RESPONSIBLE FOR OBTAINING ALL NECESSARY PERMITS AND APPROVALS FROM ALL APPLICABLE AGENCIES.

CONCRETE SPECIFICATIONS

1. CONCRETE SHALL BE PLACED AND FINISHED TO THE FINISHED SURFACE.
2. ALL CONCRETE SHALL BE PLACED AND FINISHED TO THE FINISHED SURFACE.
3. ALL CONCRETE SHALL BE PLACED AND FINISHED TO THE FINISHED SURFACE.
4. ALL CONCRETE SHALL BE PLACED AND FINISHED TO THE FINISHED SURFACE.
5. ALL CONCRETE SHALL BE PLACED AND FINISHED TO THE FINISHED SURFACE.
6. ALL CONCRETE SHALL BE PLACED AND FINISHED TO THE FINISHED SURFACE.
7. ALL CONCRETE SHALL BE PLACED AND FINISHED TO THE FINISHED SURFACE.
8. ALL CONCRETE SHALL BE PLACED AND FINISHED TO THE FINISHED SURFACE.
9. ALL CONCRETE SHALL BE PLACED AND FINISHED TO THE FINISHED SURFACE.
10. ALL CONCRETE SHALL BE PLACED AND FINISHED TO THE FINISHED SURFACE.
11. ALL CONCRETE SHALL BE PLACED AND FINISHED TO THE FINISHED SURFACE.
12. ALL CONCRETE SHALL BE PLACED AND FINISHED TO THE FINISHED SURFACE.
13. ALL CONCRETE SHALL BE PLACED AND FINISHED TO THE FINISHED SURFACE.
14. ALL CONCRETE SHALL BE PLACED AND FINISHED TO THE FINISHED SURFACE.
15. ALL CONCRETE SHALL BE PLACED AND FINISHED TO THE FINISHED SURFACE.
16. ALL CONCRETE SHALL BE PLACED AND FINISHED TO THE FINISHED SURFACE.
17. ALL CONCRETE SHALL BE PLACED AND FINISHED TO THE FINISHED SURFACE.
18. ALL CONCRETE SHALL BE PLACED AND FINISHED TO THE FINISHED SURFACE.
19. ALL CONCRETE SHALL BE PLACED AND FINISHED TO THE FINISHED SURFACE.
20. ALL CONCRETE SHALL BE PLACED AND FINISHED TO THE FINISHED SURFACE.
21. ALL CONCRETE SHALL BE PLACED AND FINISHED TO THE FINISHED SURFACE.
22. ALL CONCRETE SHALL BE PLACED AND FINISHED TO THE FINISHED SURFACE.
23. ALL CONCRETE SHALL BE PLACED AND FINISHED TO THE FINISHED SURFACE.
24. ALL CONCRETE SHALL BE PLACED AND FINISHED TO THE FINISHED SURFACE.
25. ALL CONCRETE SHALL BE PLACED AND FINISHED TO THE FINISHED SURFACE.
26. ALL CONCRETE SHALL BE PLACED AND FINISHED TO THE FINISHED SURFACE.
27. ALL CONCRETE SHALL BE PLACED AND FINISHED TO THE FINISHED SURFACE.
28. ALL CONCRETE SHALL BE PLACED AND FINISHED TO THE FINISHED SURFACE.
29. ALL CONCRETE SHALL BE PLACED AND FINISHED TO THE FINISHED SURFACE.
30. ALL CONCRETE SHALL BE PLACED AND FINISHED TO THE FINISHED SURFACE.
31. ALL CONCRETE SHALL BE PLACED AND FINISHED TO THE FINISHED SURFACE.
32. ALL CONCRETE SHALL BE PLACED AND FINISHED TO THE FINISHED SURFACE.
33. ALL CONCRETE SHALL BE PLACED AND FINISHED TO THE FINISHED SURFACE.
34. ALL CONCRETE SHALL BE PLACED AND FINISHED TO THE FINISHED SURFACE.
35. ALL CONCRETE SHALL BE PLACED AND FINISHED TO THE FINISHED SURFACE.
36. ALL CONCRETE SHALL BE PLACED AND FINISHED TO THE FINISHED SURFACE.
37. ALL CONCRETE SHALL BE PLACED AND FINISHED TO THE FINISHED SURFACE.
38. ALL CONCRETE SHALL BE PLACED AND FINISHED TO THE FINISHED SURFACE.
39. ALL CONCRETE SHALL BE PLACED AND FINISHED TO THE FINISHED SURFACE.
40. ALL CONCRETE SHALL BE PLACED AND FINISHED TO THE FINISHED SURFACE.
41. ALL CONCRETE SHALL BE PLACED AND FINISHED TO THE FINISHED SURFACE.
42. ALL CONCRETE SHALL BE PLACED AND FINISHED TO THE FINISHED SURFACE.
43. ALL CONCRETE SHALL BE PLACED AND FINISHED TO THE FINISHED SURFACE.
44. ALL CONCRETE SHALL BE PLACED AND FINISHED TO THE FINISHED SURFACE.
45. ALL CONCRETE SHALL BE PLACED AND FINISHED TO THE FINISHED SURFACE.
46. ALL CONCRETE SHALL BE PLACED AND FINISHED TO THE FINISHED SURFACE.
47. ALL CONCRETE SHALL BE PLACED AND FINISHED TO THE FINISHED SURFACE.
48. ALL CONCRETE SHALL BE PLACED AND FINISHED TO THE FINISHED SURFACE.
49. ALL CONCRETE SHALL BE PLACED AND FINISHED TO THE FINISHED SURFACE.
50. ALL CONCRETE SHALL BE PLACED AND FINISHED TO THE FINISHED SURFACE.

	TX-HOU0485A	Clear Wireless, LLC		BC ARCHITECTS ENGINEERS P.O. BOX 1000 HOUSTON, TEXAS 77255 TELEPHONE: 713.865.1234 FAX: 713.865.1235 WWW.BCARCHITECTS.COM
FOR 5, 4TH STREET HOUSTON, TX 77008	DATE: 08/15/2018 BY: J. SMITH CHECKED: M. JONES SCALE: AS SHOWN	PROJECT: CLEAR WIRELESS SHEET: ELECTRICAL NOTES DATE: 08/15/2018 BY: J. SMITH	ELECTRICAL NOTES SHEET NO. 04 OF 04	