

REVIEW BY FORT BEND COUNTY COMMISSIONERS COURT

On this 26 day of JULY, 2011, before the Fort Bend Commissioners Court came on to be heard and reviewed the accompanying notice of IDENTITY HOMES

Job Location BLOOMMIST COURT

Dated 07/19/11 BOND NO. 5073151 Permit No. 83987

to make use of certain Fort Bend County property subject to, "A Revised Order Regulating the Laying, Construction, Maintenance, and Repair of Buried Cables, Conduits, and Pole Lines, In, Under, Across or Along Roads, Streets, Highways, and Drainage Ditches in Fort Bend County, Texas, Under the Jurisdiction of the Commissioners Court of Fort Bend County, Texas," as passed by the Commissioners Court of Fort Bend County, Texas, date the 3rd day of August, 1987, recorded in Volume _____ of the Minutes of the Commissioners Court of Fort Bend County, Texas, to the extent that such order is not inconsistent with Article 1436a, Vernon's Texas Civil Statues. Upon Motion of Commissioner Meyers, seconded by Commissioner Patterson, duly put and carried, it is ORDERED, ADJUGED AND DECREED that said notice of said above purpose is hereby acknowledged by the Commissioners Court of Fort Bend County, Texas, and that said notice be placed on record according to the regulation order thereof.

Notes:

- 1. Evidence of review by the Commissioners Court must be kept on the job site and failure to do so constitutes grounds for job shutdown.
- 2. Written notices are required:
 - a. 48 hours in advance of construction start up, and
 - b. When construction is completed and ready for final inspection

Mail notices to: Permit Administrator
Fort Bend County Engineering
P.O. Box 1449
Rosenberg, Texas 77471
281-633-7500

- 3. This permit expires one (1) year from date of permit if construction has not commenced.

By [Signature]
County Engineer

Presented to Commissioners Court and approved.

By [Signature]
Drainage District Engineer/Manager

Recorded in Volume 7-26-11
Minutes of Commissioners Court.

Clerk of Commissioners Court

By [Signature]
Deputy

**FORT BEND COUNTY ENGINEERING
 PERMIT DEPARTMENT
 CONSTRUCTION OF DRIVEWAYS AND CULVERTS ON COUNTY EASEMENTS AND RIGHT OF WAYS
 COMMERCIAL PIPE PERMIT APPLICATION
 P.O. BOX 1449 • 1124 BLUME ROAD
 ROSENBERG, TX 77471
 (Phone) 281-633-7502 or 7503 • (Fax) 281-342-7366**

APPLICANT INFORMATION

Application No. 83987
 (County Use Only)

Applicant Name Identity Home
 Applicant Mailing Address 207 north st
 City Richmond State TX Zip 77469
 Work Phone 281-344-8727 Daytime Phone _____
 Property Owner's Name Same Phone _____
 Property Owner's Mailing Address _____
 City _____ State _____ Zip _____

LOCATION OF PROPERTY

Subdivision 2026 Blum mist cut Sec 1 Lot 20 Blk 5
 Physical Address Walnut creek sub

(ATTACH A SITE MAP)

SITE USE

Driveway Curb & Gutter Section _____ Driveway - Open Ditch Section _____
 Culvert Only _____

DRIVEWAY REQUIREMENTS

Length 20' minimum and 40' maximum Number of drives 1
 (See - Fort Bend County Procedures to be followed for Commercial Driveway, and Median Openings or Modifications)
 Available on website www.co.fort-bend.tx.us

Does project comply with Fort Bend County Lighting Regulation Yes () No ()
 (See- Fort Bend County Outdoor Lighting Regulation on website www.co.fort-bend.tx.us)

- By signing and submitting this permit application, I am stating that I am the owner of this property and I am aware of and agree to abide by the Fort Bend County Regulations of Subdivisions and I am aware of Section 2, Item F in the Permits for the Construction of Driveways & Culverts on County Easements and Right of Ways in Fort Bend County, and am responsible to obtain all other required permits associated with the above mentioned property. Driveway and Pipe Permits shall provide that construction pursuant to the permit will be commenced within six months and be completed within nine months from the date of the permit and that fees collected for said permits shall not be refundable or transferable. I further understand the permit fee, in the form of CASH or PERSONAL CHECK or COMPANY CHECK or a CASHIERS CHECK or MONEY ORDER payable to FORT BEND COUNTY, must be attached.
- The undersigned applicant, agent or attorney hereby certifies to Commissioners' Court to be strictly bound to Commissioners' Court to construct the driveway and/or culvert in strict conformity with the plans, specifications, terms, provisions and conditions of the permit and any other written material incorporated by reference in this application.
- Other permits may be required for development. Please contact the Fort Bend County Road & Bridge Department for pipe sizing or the Fort Bend County Health Department for information on On-Site Sewage Facility permits prior to planning construction.
- Failure to possess or obtain required permits will result in legal action against the property owner as allowed by law.

Signature of Applicant, Agent or Attorney [Signature] Date 7/14/2011
 Printed Name Jim Caputo

WHEN A RESIDENTIAL SIDEWALK, DRIVEWAY OR CURB OR GUTTER IS CONSTRUCTED, RECONSTRUCTED, REPAIRED OR REGRADED ON COUNTY RIGHT-OF-WAY. FOR USE WITH CONCRETE OR ASPHALT CURBED TYPE STREETS, USE SECTIONS APPLICABLE.

C. USE FOR ALL PROPOSED DRIVES ON CURBED TYPE STREETS:

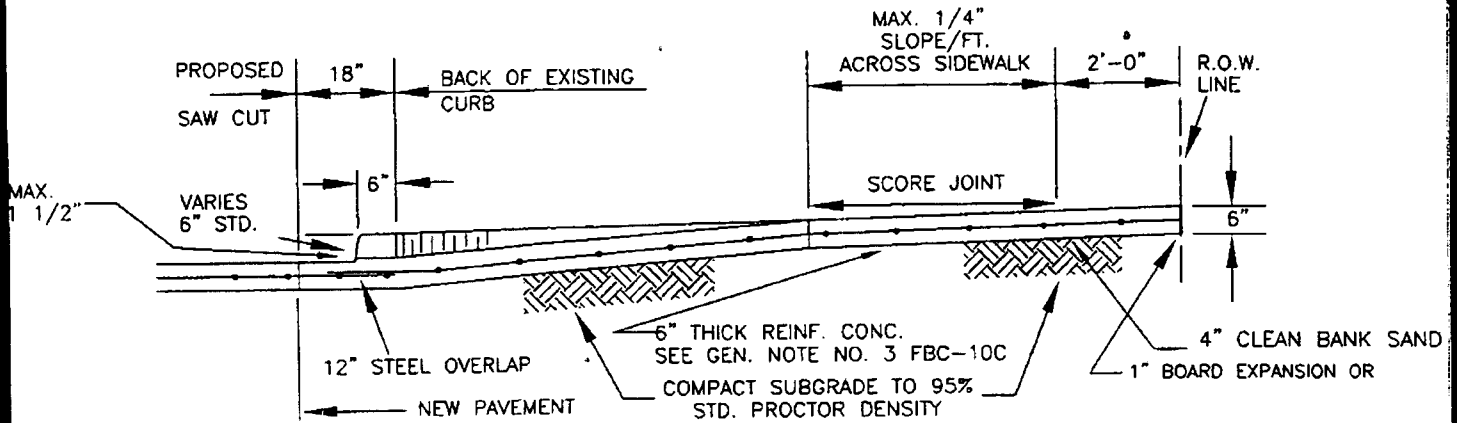

D. USE WHEN SIDEWALK TO BE BUILT OTHER THAN DRIVEWAY:

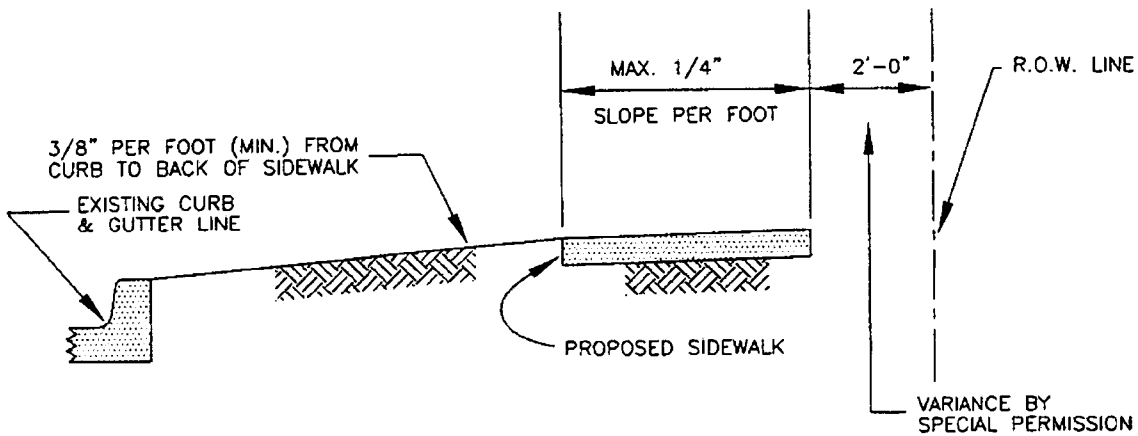

<p>SIDEWALKS & DRIVEWAYS WITH CURB TYPE STREETS RESIDENTIAL AREA</p>	<p>DRAWN BY: L. BRDECKA DATE DRAWN: 2-1-94</p>	<p>REVISED BY: L. BRDECKA DATE REVISED: 3-10-05</p>
	<p>APPROVED BY: L. HOOD DATE: 2-1-94</p>	<p>DRAWING NO. FBC-010B</p>

