

**REVIEW BY FORT BEND COUNTY COMMISSIONERS COURT**

On this 27 day of APRIL, 2010, before the Fort Bend Commissioners Court came on to be heard and reviewed the accompanying notice of LEM CONSTRUCTION CO., INC.

Job Location OYSTER CREEK

Dated 04/09/10 BOND NO. 6535017 Permit No. 83735

to make use of certain Fort Bend County property subject to, "A Revised Order Regulating the Laying, Construction, Maintenance, and Repair of Buried Cables, Conduits, and Pole Lines, In, Under, Across or Along Roads, Streets, Highways, and Drainage Ditches in Fort Bend County, Texas, Under the Jurisdiction of the Commissioners Court of Fort Bend County, Texas," as passed by the Commissioners Court of Fort Bend County, Texas, date the 3<sup>rd</sup> day of August, 1987, recorded in Volume \_\_\_\_\_ of the Minutes of the Commissioners Court of Fort Bend County, Texas, to the extent that such order is not inconsistent with Article 1436a, Vernon's Texas Civil Statues. Upon Motion of Commissioner Meyers, seconded by Commissioner Morrison, duly put and carried, it is ORDERED, ADJUGED AND DECREED that said notice of said above purpose is hereby acknowledged by the Commissioners Court of Fort Bend County, Texas, and that said notice be placed on record according to the regulation order thereof.

Notes:

1. Evidence of review by the Commissioners Court must be kept on the job site and failure to do so constitutes grounds for job shutdown.
2. Written notices are required:
  - a. 48 hours in advance of construction start up, and
  - b. When construction is completed and ready for final inspection

Mail notices to: Permit Administrator  
Fort Bend County Engineering  
P.O. Box 1449  
Rosenberg, Texas 77471  
281-633-7500

3. This permit expires one (1) year from date of permit if construction has not commenced.

By [Signature]  
County Engineer

By [Signature]  
Drainage District Engineer/Manager

Presented to Commissioners Court and approved.

Recorded in Volume 4-22-10 Minutes of Commissioners Court.

Clerk of Commissioners Court

By [Signature]  
Deputy

**PERFORMANCE BOND COVERING ALL CABLE, CONDUIT AND/OR POLE LINE  
ACTIVITY IN, UNDER, ACROSS OR ALONG FORT BEND COUNTY ROADS**

**AUTHORIZED**

BOND NO 6535017

THE STATE OF TEXAS §

KNOW ALL MEN BY THESE PRESENTS:

COUNTY OF FORT BEND §

THAT WE LEM Construction Company, Inc. whose address is 10849 Kinghurst #150, Houston, Texas, hereinafter called the Principal, and Safeco Ins. Co. of America, a Corporation existing under and by virtue of the laws of the State of Texas and authorized to do an indemnifying business in the State of Texas, and whose principal office is located at 1600 N Collins Blvd, Richards, whose officer residing in the State of Texas, authorized to accept service in all suits and actions brought within said State is Texas and whose address is 13201 NW Frwy #600, Houston, TX, hereinafter called the Surety, and held and firmly bound unto, Robert E. Hebert, County Judge of Fort Bend County, Texas, or his successors in office, in the full sum of Five Thousand Dollars (\$5,000.) current, lawful money of the United States of America, to be paid to said Robert E. Hebert, County Judge of Fort Bend County, Texas, or his successors in office, to which payment well and truly to be made and done, we, the undersigned, bind ourselves and each of us, our heirs, executors, administrators, successors, assigns, and legal representatives, jointly and severally, by these presents.

THE CONDITION OF THIS BOND IS SUCH THAT, WHEREAS, the above bounden principal contemplates laying, constructing, maintaining and/or repairing one or more cables, conduits, and/or pole lines in, under, across and/or along roads, streets and highways in the County of Fort Bend, and the State of Texas, under the jurisdiction of the Commissioners' Court of Fort Bend County, Texas, pursuant to the Commissioners' Court order adopted on the 1st day of December, A.D. 1980, recorded in Volume 13, of the Commissioners' Court Minutes of Fort Bend County, Texas, regulating same, which Commissioners' Court order is hereby referred to and made a part hereof for all purposes as though fully set out herein;

AND WHEREAS, the principal desires to provide Fort Bend County with a performance bond covering all such cable, conduit and/or pole line activity;

NOW, THEREFORE, if the above bounden principal shall faithfully perform all its cable, conduit and/or pole line activity (including, but not limited to the laying, construction, maintenance and/or repair of cables, conduits and/or pole lines) in, under, across and/or along roads, streets and highways in the County of Fort Bend and State of Texas, under the jurisdiction of the Commissioners Court of Fort Bend County, Texas, pursuant to and in accordance with minimum requirements and conditions of the above mentioned Commissioners' Court order set forth and specified to be by said principal done and performed, at the time and in the manner therein specified, and shall pay over and make good and reimburse Fort Bend County, all loss and damages which Fort Bend County may sustain by reason of any failure or default on the part of said principal, then this obligation shall be null and void, otherwise to remain in full force and effect.

This bond is payable at the County Courthouse in the County of Fort Bend and State of Texas.

It is understood that at any time Fort Bend County deems itself insecure under this bond, it may require further and/or additional bonds of the principal.

EXECUTED this 30th day of March, 2010.

LEM Construction Company, Inc.  
PRINCIPAL

Larry Laird II, President  
BY Larry Laird II, President

Safeco Insurance Co. of America  
SURETY

Karen Brooks  
BY Karen Brooks, Attorney-In-Fact



POWER OF ATTORNEY

Safeco Insurance Company of America
General Insurance Company of America
1001 4th Avenue
Suite 1700
Seattle, WA 98154

No. 10551

KNOW ALL BY THESE PRESENTS:

That SAFECO INSURANCE COMPANY OF AMERICA and GENERAL INSURANCE COMPANY OF AMERICA, each a Washington corporation, does each hereby appoint

JAMES BERRY; KAREN BROOKS; JAMES D. FRITH; SAM KING; SUSAN PALMER; Houston, Texas

its true and lawful attorney(s)-in-fact, with full authority to execute on its behalf fidelity and surety bonds or undertakings and other documents of a similar character issued in the course of its business, and to bind the respective company thereby.

IN WITNESS WHEREOF, SAFECO INSURANCE COMPANY OF AMERICA and GENERAL INSURANCE COMPANY OF AMERICA have each executed and attested these presents

this 21st day of March, 2009

Dexter R. Legg

T. Mikolajewski

Dexter R. Legg, Secretary

Timothy A. Mikolajewski, Vice President

CERTIFICATE

Extract from the By-Laws of SAFECO INSURANCE COMPANY OF AMERICA and of GENERAL INSURANCE COMPANY OF AMERICA:

"Article V, Section 13. - FIDELITY AND SURETY BONDS ... the President, any Vice President, the Secretary, and any Assistant Vice President appointed for that purpose by the officer in charge of surety operations, shall each have authority to appoint individuals as attorneys-in-fact or under other appropriate titles with authority to execute on behalf of the company fidelity and surety bonds and other documents of similar character issued by the company in the course of its business...

Extract from a Resolution of the Board of Directors of SAFECO INSURANCE COMPANY OF AMERICA and of GENERAL INSURANCE COMPANY OF AMERICA adopted July 28, 1970.

"On any certificate executed by the Secretary or an assistant secretary of the Company setting out,

- (i) The provisions of Article V, Section 13 of the By-Laws, and
(ii) A copy of the power-of-attorney appointment, executed pursuant thereto, and
(iii) Certifying that said power-of-attorney appointment is in full force and effect,

the signature of the certifying officer may be by facsimile, and the seal of the Company may be a facsimile thereof."

I, Dexter R. Legg, Secretary of SAFECO INSURANCE COMPANY OF AMERICA and of GENERAL INSURANCE COMPANY OF AMERICA, do hereby certify that the foregoing extracts of the By-Laws and of a Resolution of the Board of Directors of these corporations, and of a Power of Attorney issued pursuant thereto, are true and correct, and that both the By-Laws, the Resolution and the Power of Attorney are still in full force and effect.

IN WITNESS WHEREOF, I have hereunto set my hand and affixed the facsimile seal of said corporation

this 30th day of March, 2010



Dexter R. Legg

Dexter R. Legg, Secretary

Figure: 28 TAC §1.601(a)(3)

**1 IMPORTANT NOTICE**

**AVISO IMPORTANTE**

To obtain information or make a complaint:

Para obtener información o para someter una queja:

2 You may contact Home Office Surety at 1-206-473-3799

Usted puede contactar a servicio de la oficina principal de Safeco Surety al: 1-206-473-3799

3 You may call (company)'s toll-free telephone number for information or to make a complaint at:

Usted puede llamar al número de teléfono gratis de (company)'s para información o para someter una queja al:

**(800) 472-5357 Surety Option #7**

**(800) 472-5357 Surety Opción De #7**

4 You may also write to Safeco Insurance Company at:  
PO Box 34526  
Seattle, WA 98124-1526

Usted también puede escribir a Safeco Insurance Company  
PO Box 34526  
Seattle, WA 98124-1526

5 You may contact the Texas Department of Insurance to obtain information on companies, coverages, rights or complaints at:

Puede comunicarse con el Departamento de Seguros de Texas para obtener información acerca de compañías, coberturas, derechos o quejas al:

**(800) 252-3439**

**(800) 252-3439**

6 You may write the Texas Department of Insurance:

Puede escribir al Departamento de Seguros de Texas:

P.O. Box 149104  
Austin, TX 78714-9104  
Fax: (512) 475-1771  
Web: <http://www.tdi.state.tx.us>  
E-mail: [ConsumerProtection@tdi.state.tx.us](mailto:ConsumerProtection@tdi.state.tx.us)

P.O. Box 149104  
Austin, TX 78714-9104  
Fax: (512) 475-1771  
Web: <http://www.tdi.state.tx.us>  
E-mail: [ConsumerProtection@tdi.state.tx.us](mailto:ConsumerProtection@tdi.state.tx.us)

**7 PREMIUM OR CLAIM DISPUTES:**

Should you have a dispute concerning your premium or about a claim you should contact the (agent) (company) (agent or the company) first. If the dispute is not resolved, you may contact the Texas Department of Insurance.

**DISPUTAS SOBRE PRIMAS O RECLAMOS:**

Si tiene una disputa concerniente a su prima o a un reclamo, debe comunicarse con el (agente) (la compañía) (agente o la compañía) primero. Si no se resuelve la disputa, puede entonces comunicarse con el departamento (TDI).

**8 ATTACH THIS NOTICE TO YOUR POLICY:**

This notice is for information only and does not become a part or condition of the attached document.

**UNA ESTE AVISO A SU POLIZA:**

Este aviso es sólo para propósito de información y no se convierte en parte o condición del documento adjunto.



**NOTICE OF PROPOSED CABLE, CONDUIT AND/OR POLE LINE ACTIVITY  
IN, UNDER, ACROSS OR ALONG ROADS, STREETS, HIGHWAYS AND DRAINAGE DITCHES  
IN FORT BEND COUNTY**

APPLICANT'S JOB NO. 2010-01  
 PERMIT No. 83735 PCT. No. 3  
 BOND No. 6535017

Formal notice is hereby given that LEM CONSTRUCTION Co., INC.  
 proposes to lay, construct, maintain and/or repair cable, conduit and/or pole line, in, under,  
 across, or along roads, streets, highways and drainage ditches in Fort Bend County, as follows:

**In, Under, or Across Roads and/or Drainage Ditches**

Road or Ditch Name	Distance & Direction From Nearest Intersection	Length of Crossing	Type of Construction
			Bored: Jacked: Driven: Cased
<del>SKINNER LANE</del>	<del>APPROX 1/2 MI NORTH FROM INTERSECTION</del>		

**Along Roads and/or Drainage Ditches**

Road or Ditch Name	Distance & Direction From Nearest Intersection	To	Distance
<u>OYSTER CREEK</u>	<u>APPROX. 1/3 MI. NORTH</u>		
	<u>AT INTERSECTION OF FARMER RD AND SKINNER LANE</u>		
<u>SKINNER LANE</u>	<u>1/2 MI NW FROM INTERSECTION OF FARMER RD + SKINNER LN.</u>		

**General Description**

24" STORM DRAIN OUTFALL FROM PELCAN GROVE MUD WATER PLANT

The Location and description of the proposed installation and appurtenances is more fully shown on the attached detail drawings. The laying, construction, maintenance and/or repair of the proposed installation shall be subject to "A Revised Order Regulating the Laying, Construction, Maintenance and/or Repair of Cables, Conduits, and/or Pole Lines, In, Under, Across, or Along Roads, Streets, Highways and Drainage Ditches in Fort Bend County, Texas, Under the Jurisdiction of the Commissioners Court of Fort Bend County, Texas," as passed by Commissioners Court of Fort Bend County, Texas, dated the 3rd. day of August, 1987, recorded in Volume 639 of the Minutes of the Commissioners Court of Fort Bend County, Texas.

- Written notices are required: 1) 48 hours in advance of start of construction and  
 2) when construction is complete and ready for final inspection.

Mail to: Permit Administrator/Fort Bend County Engineering  
 P.O. Box 1449, Rosenberg, TX 77471.

Violation of requirements shall constitute grounds for job shut down.

COMPANY NAME: LEM CONSTRUCTION Co., INC.  
 AGENT and/or OWNER

Kenneth Strinker  
 (Signature)

NAME & TITLE KENNETH STRINKER, VICE PRES.  
 (Please Print)

DATE 3/29/10

ADDRESS 10849 KINGHURST ST, SUITE 150  
 (Street/P.O. Box)

HOUSTON TX 77019  
 City State Zip

TELEPHONE NO: 281-744-8257  
 (accessible 24 hrs/day, 7 days/week)

Does project comply with Fort Bend County Outdoor Lighting Ordinance?
Yes ( )
No ( )





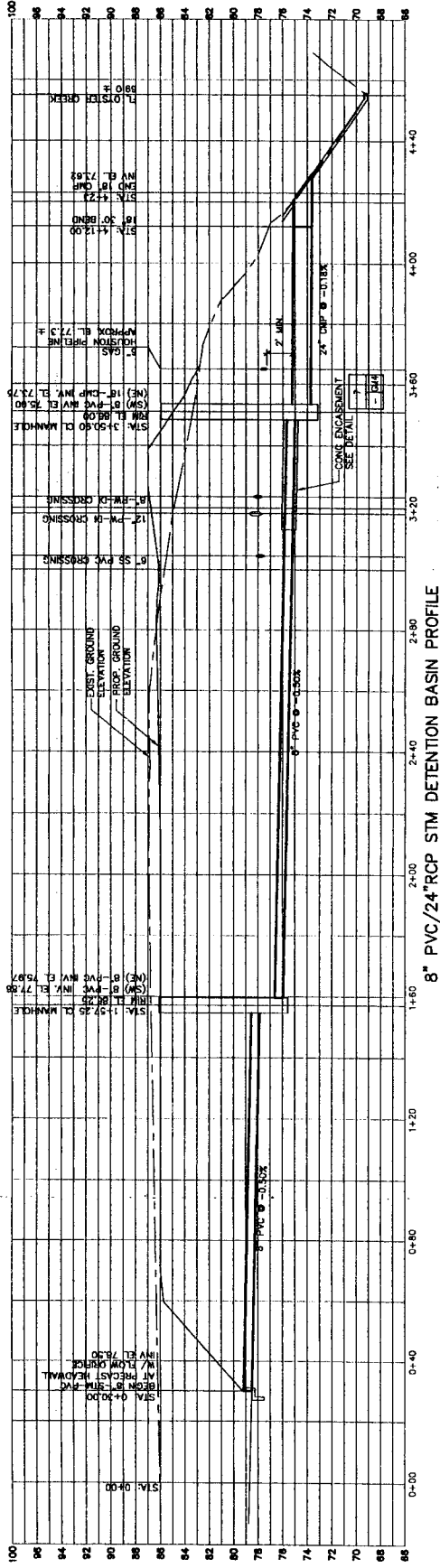

8" PVC/24" RCP STM DETENTION BASIN PROFILE

**CONFORMED DRAWING**  
 This document is a conforming document. It is a copy of the original drawing as submitted to the City of Dallas. It is not to be used for any other purpose. If there are discrepancies between this conforming document and the original drawing, the original drawing shall govern. The contract documents are as defined in the agreement.

**NOTES:**  
 1. PROVIDE CONCRETE ENCASUREMENT ON B' AND 24" STM STA. 3+13 TO STA. 4+30.

FIRM REGISTRATION No. 15873



**MALCOLM PIRNIE**

PECAN GROVE MUNICIPAL UTILITY DISTRICT  
**SURFACE WATER TREATMENT PLANT**

CIVIL  
**YARD PIPING PROFILE 1**

SCALE: VERT. 1"=5', HORIZ. 1"=20'

MALCOLM PIRNIE, INC.  
 DATE: NOVEMBER 2009  
 1C11 SHEET 17 OF 259  
 CAD REF. NO. 5535006-037

DES. E. MARTINEZ  
 DWG. E. MARTINEZ  
 CVD. S. BLACK

REV.	DATE	BY	CHKD.	DESCRIPTION
A	11/17/09	SM	SM	CONFORMED DRAWING

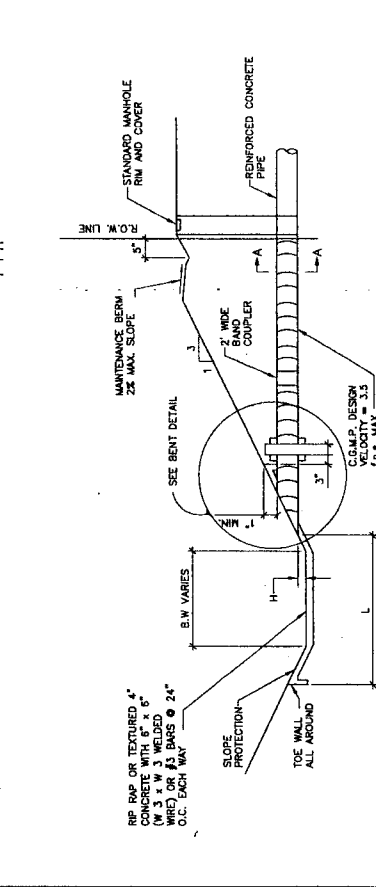
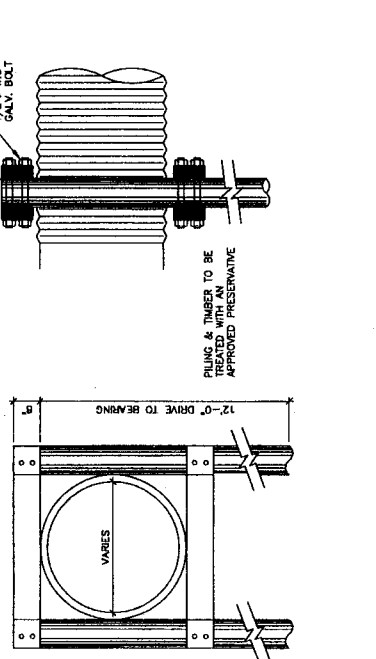
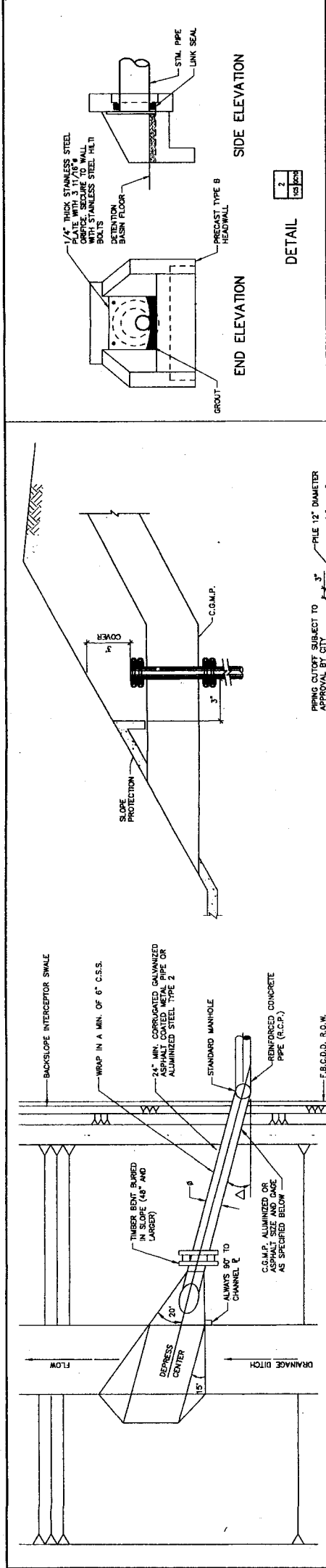

**GENERAL NOTES:**

1. INSTALL OUTFALLS 48 INCHES OR LARGER DIAMETER AND TREATMENT PLANT OUTFALLS OF ANY DIAMETER WITH RRPPAP EROSION PROTECTION, DIMENSIONED AS SHOWN IN TYPICAL STORM SEWER OUTFALL STRUCTURE LAYOUT.
2. STORM SEWER AND INTERCEPTOR OUTFALL PIPES WITHIN THE FLOOD RIGHT-OF-WAY SHALL BE CORRUGATED METAL PIPE (CMP).
3. SWPPP REQUIREMENTS FOR THE CONSTRUCTION OF THE OUTFALL STRUCTURE IN OYSTER CREEK SHALL BE DEVELOPED AND IMPLEMENTED BY CONTRACTOR.
4. OYSTER CREEK IS A NATURAL DRAINAGE CHANNEL AND CANAL FOR UP TO 70 MGD OF WATER PUMPED BY GULF COAST WATER TREATMENT PLANT. CONTRACTOR SHALL PROVIDE CONSTRUCTION MEASURES REQUIRED TO CONSTRUCT OUTFALL WHILE ALLOWING WATER TO FLOW IN OYSTER CREEK.

**GENERAL NOTES:**

RRPPAP SHALL BE A MINIMUM OF 6" BROKEN CONCRETE RUBBLE WITH NO EXPOSED STEEL OR WELLS-ROUNDED STONE AND SHALL BE INSTALLED A MINIMUM OF 18" THICK.

ANY VARIATION TO THIS STANDARD MUST BE APPROVED BY F.B.C.D.D. ENGINEER.

**TABLE A**

SIZE 2' 2/3\"/>					
24"	18	18	18	18	18
30"	16	16	16	16	16
36"	16	16	16	16	16
42"	14	14	14	14	14
48"	12	12	12	12	12
54"	12	12	12	12	12
60"	10	10	10	10	10
72"	8	8	8	8	8
78"	8	8	8	8	8
84"	8	8	8	8	8

**NOTE:**

$\Delta$ : PROP. 24" TO 42"  $\Delta = 15'$   
 PROP. 48" AND LARGER  $\Delta = 30'$

H: FOR PIPE SIZES 24" TO 42" H=1' MAX. AND 1" MIN.  
 FOR PIPE SIZES 48" AND LARGER H=1' MAX. AND MIN.

L: PIPE #  $\leq 7$ -6"  $\Rightarrow$  L WILL EXTEND ONE PIPE # ABOVE P ON OPPOSITE BANK (MIN.)  
 PIPE #  $> 7$ -6"  $\Rightarrow$  L = 6' OR MIN. 1'-6" INTO BANK (WHICHEVER IS GREATER)

**CONFIRMED DRAWING**

This document is a confirmed drawing. It consists of the original document, including all sheets, and any amendments or additions (addenda) to which all the drawings (addenda) have been issued during the bid period. It has been confirmed by the contractor and the engineer. The contractor shall be responsible for the accuracy of the drawings and documents. The contractor shall be responsible for the accuracy of the drawings and documents. The contractor shall be responsible for the accuracy of the drawings and documents.

**DETAIL**

**PECAN GROVE MUNICIPAL UTILITY DISTRICT**

**SURFACE WATER TREATMENT PLANT**

**CIVIL DETAILS SHEET 10 OF 10**

**NOT TO SCALE**

**MALCOLM PIRNIE INC.**

DATE: NOVEMBER 2009

SHEET 33 OF 259

CAD REF. NO. SB36006-054

**FIRM REGISTRATION No. F-379**

**MALCOLM PIRNIE**