

NOTICE OF PROPOSED CABLE, CONDUIT AND/OR POLE LINE ACTIVITY  
IN, UNDER, ACROSS OR ALONG ROADS, STREETS, HIGHWAYS AND DRAINAGE DITCHES  
IN FORT BEND COUNTY

APPLICANT'S JOB NO. 0936-113  
PERMIT No. 83723 PCT. No. \_\_\_\_\_  
BOND No. LPM 8979685

Formal notice is hereby given that \_\_\_\_\_  
proposes to lay, construct, maintain and/or repair cable, conduit and/or pole line, in, under,  
across, or along roads, streets, highways and drainage ditches in Fort Bend County, as follows:

In, Under, or Across Roads and/or Drainage Ditches

Road or Ditch Name	Distance & Direction From	Length of Crossing	Type of Construction
	Nearest Intersection		Bored: Jacked: Driven: Cased
Ditch II-B-7-A	1100' WEST along Ditch from Sunrise Meadows Dr. and Primrose Gate	50'	Water Line

Along Roads and/or Drainage Ditches

Road or Ditch Name	Distance & Direction From	To	Distance
	Nearest Intersection		

General Description

6" Waterline in Ditch II-B-7-A

The Location and description of the proposed installation and appurtenances is more fully shown on the attached detail drawings. The laying, construction, maintenance and/or repair of the proposed installation shall be subject to "A Revised Order Regulating the Laying, Construction, Maintenance and/or Repair of Cables, Conduits, and/or Pole Lines, In, Under, Across, or Along Roads, Streets, Highways and Drainage Ditches in Fort Bend County, Texas, Under the Jurisdiction of the Commissioners Court of Fort Bend County, Texas," as passed by Commissioners Court of Fort Bend County, Texas, dated the 3rd. day of August, 1987, recorded in Volume 639 of the Minutes of the Commissioners Court of Fort Bend County, Texas.

Written notices are required: 1) 48 hours in advance of start of construction and  
2) when construction is complete and ready for final inspection.

Mail to: Permit Administrator/Fort Bend County Engineering  
P.O. Box 1448, Rosenberg, TX 77471.

Violation of requirements shall constitute grounds for job shut down.

COMPANY NAME: JAHO INC.  
AGENT and/or OWNER

[Signature]  
(Signature)

NAME & TITLE: VICE-PRESIDENT  
(Please Print)

DATE: 5-5-10

ADDRESS: 2003 Wilson Rd.  
(Street/P.O. Box)

Humble TX 77396  
City State Zip

TELEPHONE NO: 281-446-4781  
(accessible 24 hrs/day, 7 days/week)

Does project comply with Fort Bend County Outdoor Lighting Ordinance?

Yes (  )

No (  )

WHEATSTONE CT.

REMOVE EX. WL PLUG AND CONNECT WITH 6" WL

BLOCK 3

32

35

Exist  
1-6"x6" Tee  
1-6" Gv w/ Box  
1-6" Gv w/ Box

PROP  
2-6" 45° BENDS

54 LF 6" WELDED STEEL WL  
5' BELOW BOTTOM OF DITCH  
SEE SECTION A-A THIS SHEET

Lf 24"  
v @ 0.34%

Exist  
1-6" 21° Bend

33

34

Exist 31 Lf 24"  
Stm Sew @ 0.26%

Sta 5+00, Lt & Rt  
Exist Backslope Drain &  
24" Cmp Stm Sew Pipe |  
Drain El= 80.90  
6' Bot Ditch Fl El= 77.23

PROP. 218 LF 24" RCP  
STM SEW @ 0.20%

PROP. 255 LF 36" RCP  
STM SEW @ 0.11%

ROP. 45° ELL

Fl El 24" = 78.10'

Exist 45 Lf 24"  
Stm Sew @ 0.2%

PROP. 30" STM SEW

PROP. TY "A" INLET  
TG.=83.85

ARBORVINE CT. (SEE SHEET 10)

66  
PLAT BOUN

EXIST. CHANN

100' D.E.

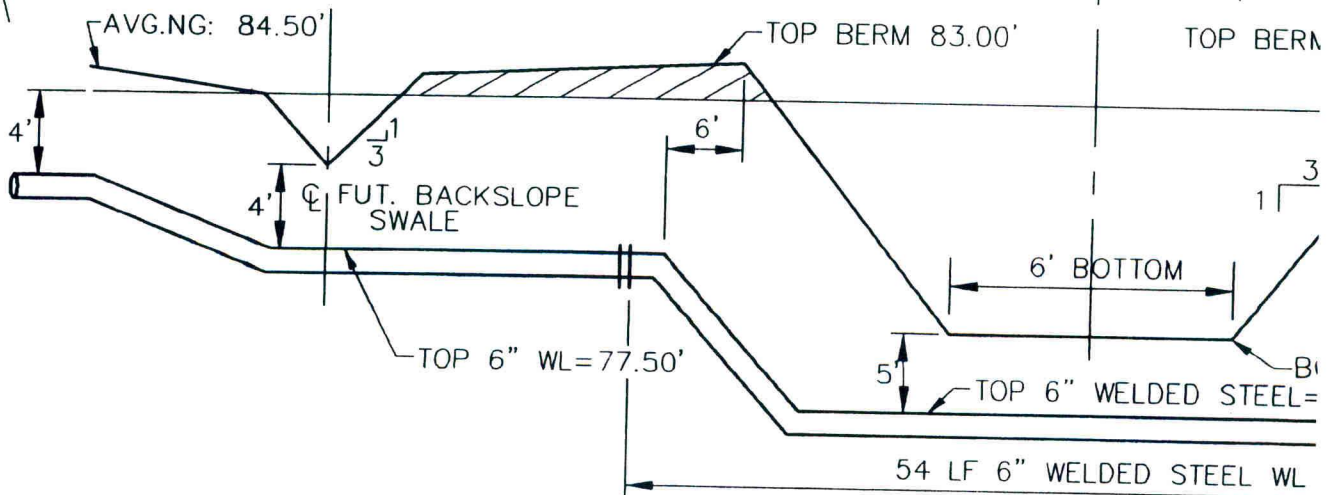
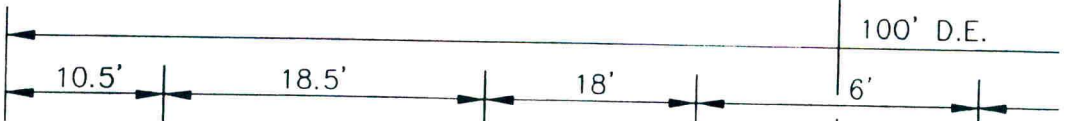

TYPICAL SECTION A-A

54 LF 6 WELDED STEEL WL

TYPICAL SECTION A-A  
NTS

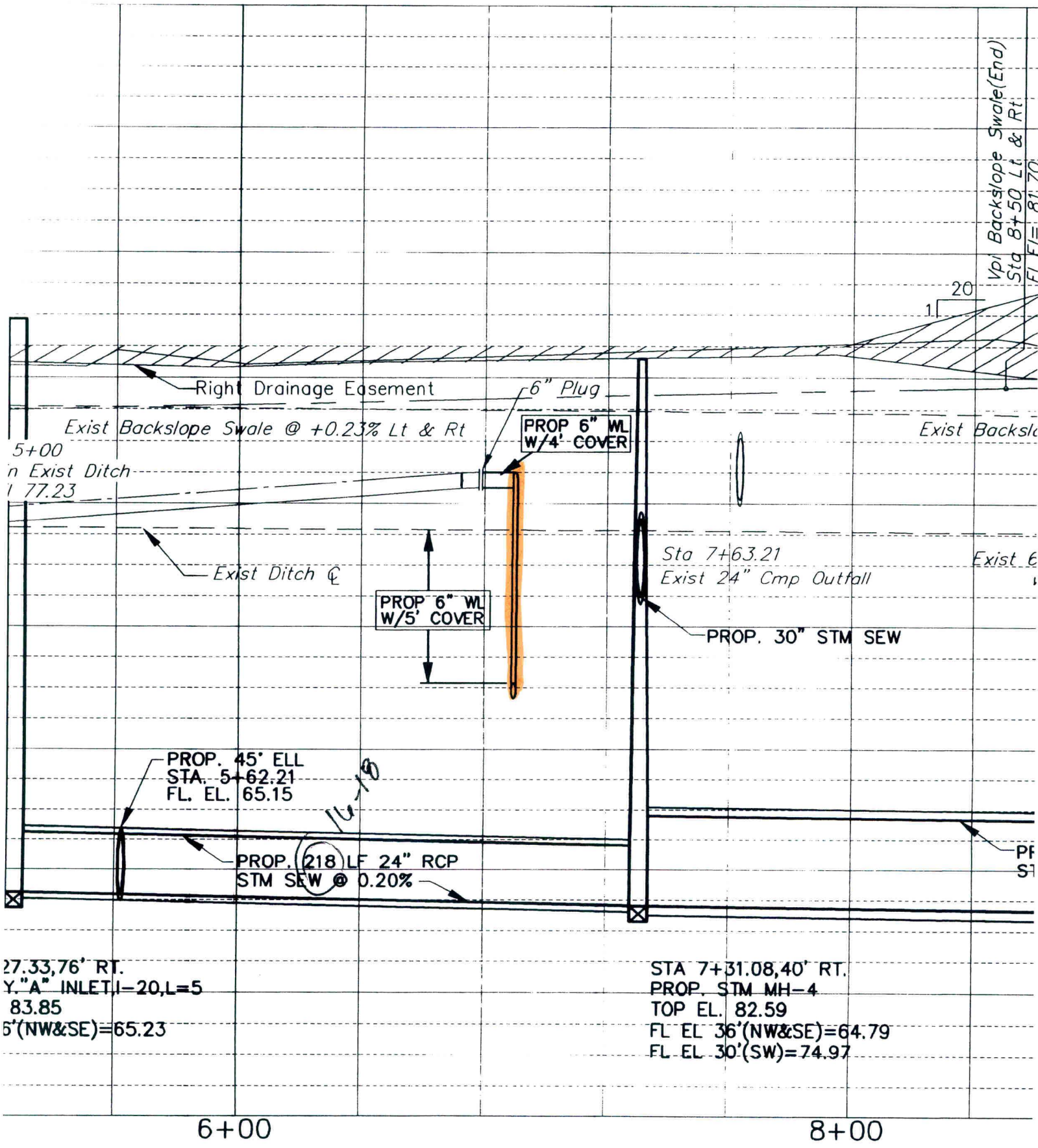

<p>on DS er</p>	<p>OWNER: <b>LGI HOMES, INC. SUNRISE MEADOW, LTD</b></p>	<p>PLAN: </p>
-------------------------	--	---------------



**REVIEW BY FORT BEND COUNTY COMMISSIONERS COURT**

On this 23 day of MARCH, 2010, before the Fort Bend Commissioners Court came on to be heard and reviewed the accompanying notice of J AHO INC.

Job Location DITCH II-B-7-A

Dated 03/16/10 BOND NO. LPM 8979685 Permit No. 83723

to make use of certain Fort Bend County property subject to, "A Revised Order Regulating the Laying, Construction, Maintenance, and Repair of Buried Cables, Conduits, and Pole Lines, In, Under, Across or Along Roads, Streets, Highways, and Drainage Ditches in Fort Bend County, Texas, Under the Jurisdiction of the Commissioners Court of Fort Bend County, Texas," as passed by the Commissioners Court of Fort Bend County, Texas, date the 3<sup>rd</sup> day of August, 1987, recorded in Volume \_\_\_\_\_ of the Minutes of the Commissioners Court of Fort Bend County, Texas, to the extent that such order is not inconsistent with Article 1436a, Vernon's Texas Civil Statues. Upon Motion of Commissioner Meyers, seconded by Commissioner Patterson, duly put and carried, it is ORDERED, ADJUGED AND DECREED that said notice of said above purpose is hereby acknowledged by the Commissioners Court of Fort Bend County, Texas, and that said notice be placed on record according to the regulation order thereof.

**Notes:**

1. Evidence of review by the Commissioners Court must be kept on the job site and failure to do so constitutes grounds for job shutdown.
2. Written notices are required:
  - a. 48 hours in advance of construction start up, and
  - b. When construction is completed and ready for final inspection

Mail notices to: Permit Administrator  
Fort Bend County Engineering  
P.O. Box 1449  
Rosenberg, Texas 77471  
281-633-7500

3. This permit expires one (1) year from date of permit if construction has not commenced.

By [Signature]  
County Engineer

By [Signature]  
Drainage District Engineer/Manager

Presented to Commissioners Court and approved.  
Recorded in Volume 3-23-10  
Minutes of Commissioners Court.

Clerk of Commissioners Court  
By [Signature]  
Deputy

# COUNTY OF FORT BEND

## Engineering Department

P.O. BOX 1449  
Rosenberg, Texas 77471-1449

Johnny Ortega  
Permit Administrator

1124 Blume Road  
Phone: (281) 341-7500

### PERMIT APPLICATION REVIEW FORM FOR CABLE, CONDUIT, AND POLE LINE ACTIVITY IN FORT BEND COUNTY

PERMIT NO. 083723

The following "Notice of Proposed Cable, Conduit, and/or Pole Line activity in Fort Bend County" and accompanying attachments have been reviewed and the notice conforms to appropriate regulations set by Commissioner's Court of Fort Bend County, Texas.

- (1) Complete Application Form.
- a. Name of road, street, and/or drainage ditch affected.
  - b. Vicinity map showing course of direction.
  - c. Plans and specifications.

- (2) Bond:
- District Attorney, approval when applicable.
  - Perpetual bond currently posted.  
No. \_\_\_\_\_  
Amount \_\_\_\_\_
  - Performance bond submitted.  
No. LPM 8979685  
Amount \$15,000.00
  - Cashier's Check.  
No. \_\_\_\_\_  
Amount \_\_\_\_\_

- (3) Verbal permission given for emergencies, to start construction before approved in Commissioner's Court.

\_\_\_\_\_  
Precinct Engineer Acknowledgment Date \_\_\_\_\_

\_\_\_\_\_  
Precinct Commissioner Acknowledgment Date \_\_\_\_\_

- (4) Adam Wright  
Drainage District Approval when applicable

We have reviewed this project and agree it meets minimum requirements.

  
\_\_\_\_\_  
Johnny Ortega CFM/Permit Administrator  
(REVISED 5/30/08)

03/11/2010  
\_\_\_\_\_  
Date

AUTHORIZED

BOND NO LPM 8979685

THE STATE OF TEXAS §

KNOW ALL MEN BY THESE PRESENTS:

COUNTY OF FORT BEND §

THAT WE, Jaho, Inc. whose address is 2003 Wilson Road, Houston, Texas, hereinafter called the Principal, and Fidelity and Deposit Company, a Corporation existing under and by virtue of the laws of the State of Maryland and authorized to do an indemnifying business in the State of Texas, and whose principal office is located at 12222 Merit Dr. #700, Dallas, TX 75251, whose officer residing in the State of Texas, authorized to accept service in all suits and actions brought within said State is Tracey Haley and whose address is 1222 Merit Drive, #1350, Dallas, TX 75251 hereinafter called the Surety, and held and firmly bound unto, Robert E. Hebert, County Judge of Fort Bend County, Texas, or his successors in office, in the full sum of Fifteen Thousand Five Hundred Dollars (\$15,500) current, lawful money of the United States of America, to be paid to said Robert E. Hebert, County Judge of Fort Bend County, Texas, or his successors in office, to which payment well and truly to be made and done, we, the undersigned, bind ourselves and each of us, our heirs, executors, administrators, successors, assigns, and legal representatives, jointly and severally, by these presents.

THE CONDITION OF THIS BOND IS SUCH THAT, WHEREAS, the above bounden principal contemplates laying, constructing, maintaining and/or repairing one or more cables, conduits, and/or pole lines in, under, across and/or along roads, streets and highways in the County of Fort Bend, and the State of Texas, under the jurisdiction of the Commissioners' Court of Fort Bend County, Texas, pursuant to the Commissioners' Court order adopted on the 1st day of December, A.D. 1980, recorded in Volume 13, of the Commissioners' Court Minutes of Fort Bend County, Texas, regulating same, which Commissioners' Court order is hereby referred to and made a part hereof for all purposes as though fully set out herein;

AND WHEREAS, the principal desires to provide Fort Bend County with a performance bond covering all such cable, conduit and/or pole line activity;

NOW, THEREFORE, if the above bounden principal shall faithfully perform all its cable, conduit and/or pole line activity (including, but not limited to the laying, construction, maintenance and/or repair of cables, conduits and/or pole lines) in, under, across and/or along roads, streets and highways in the County of Fort Bend and State of Texas, under the jurisdiction of the Commissioners Court of Fort Bend County, Texas, pursuant to and in accordance with minimum requirements and conditions of the above mentioned Commissioners' Court order set forth and specified to be by said principal done and performed, at the time and in the manner therein specified, and shall pay over and make good and reimburse Fort Bend County, all loss and damages which Fort Bend County may sustain by reason of any failure or default on the part of said principal, then this obligation shall be null and void, otherwise to remain in full force and effect.

This bond is payable at the County Courthouse in the County of Fort Bend and State of Texas.

It is understood that at any time Fort Bend County deems itself insecure under this bond, it may require further and/or additional bonds of the principal.

EXECUTED this 26th day of February, 2010.

Site Location: Sunrise Meadow Section 5

Jaho, Inc.
PRINCIPAL
BY [Signature]

Fidelity and Deposit Company of Maryland
SURETY

Gimmie Langford
BY Gimmie Langford - Attorney-in-Fact