

**UPRR REMS
Project 802086**

AGREEMENT

**RAILROAD HIGHWAY GRADE CROSSING CLOSURE
PRIVATE GRADE CROSSING DOT NO. 447867F
BROADWAY STREET
RAILROAD MILEPOST 8.507,
POPP INDUSTRIAL LEAD,
CITY OF FRESNO, COUNTY OF FORT BEND, STATE OF TEXAS**

THIS AGREEMENT ("Agreement") is made and entered into as of _____, ("Effective Date") by and between **UNION PACIFIC RAILROAD COMPANY**, a Delaware corporation ("Railroad"), the **STATE OF TEXAS**, acting by and through the Texas Department of Transportation ("State"), and **FORT BEND COUNTY**, a political subdivision of the State of Texas ("County").

RECITALS

The State and County desires to permanently close the at-grade private road crossing for Broadway Street at Railroad Milepost 8.507, DOT No. 447867F in the City of Fresno, County of Fort Bend, State of Texas on Railroad's Popp Industrial Lead (the "Roadway").

AGREEMENT

NOW THEREFORE, It is mutually agreed by and between the Railroad, State, and County as follows:

SECTION 1. County shall take all actions necessary to permanently close and vacate the Roadway, easement and/or any other rights across the Railroad's property.

SECTION 2. The Railroad, at State's expense, further agrees to remove the railroad crossing surface and warning devices (crossbuck signs, etc.) which currently exist on the Railroad's right-of-way, upon the completion of the overpass at DOT 980316N, RRMP 8.507.

SECTION 3.

A. Prior to the Railroad's removal of the crossing surface and warning devices, the State, at its expense, shall install, maintain, repair and renew permanent barricades on both sides of the Roadway with such barricades to be located off of the

Railroad's property and to be in compliance with the plans marked **Exhibit A**, attached hereto and hereby made a part hereof, and also all applicable standards and guidelines contained in the current Manual on Uniform Traffic Control Devices ("MUTCD").

B. The State, at its expense, shall also (i) provide new advance street signs and pavement markings to indicate that the Roadway is closed, with such signage to be in compliance with applicable current MUTCD standards and guidelines, (ii) remove all Roadway approach surfaces up to the track tie ends, (iii) restore drainage and ditch lines, and (iv) require its contractor to execute the Railroad's Contractor's Right of Entry Agreement marked **Exhibit B**, attached hereto and hereby made a part hereof, and for the contractor to provide to Railroad the insurance policies, certificates and endorsements required therein before allowing any contractor to commence any work on Railroad's property.

IN WITNESS WHEREOF, the parties hereto have duly executed this Agreement as of the Effective Date first herein written.

UNION PACIFIC RAILROAD COMPANY

By: _____
Printed Name: _____
Title: _____

COUNTY OF FORT BEND

By: _____
Printed Name: _____
Title: _____

THE STATE OF TEXAS

Executed for the Executive Director and approved for the Texas Transportation Commission for the purpose and effect of activating and/or carrying out the orders, established policies, or work programs heretofore approved and authorized by the Texas Transportation Commission.

By _____
Printed Name: Donald Franks
Title: Rail Division Director

EXHIBIT A

Exhibit A is the plans referenced in Section 3A.

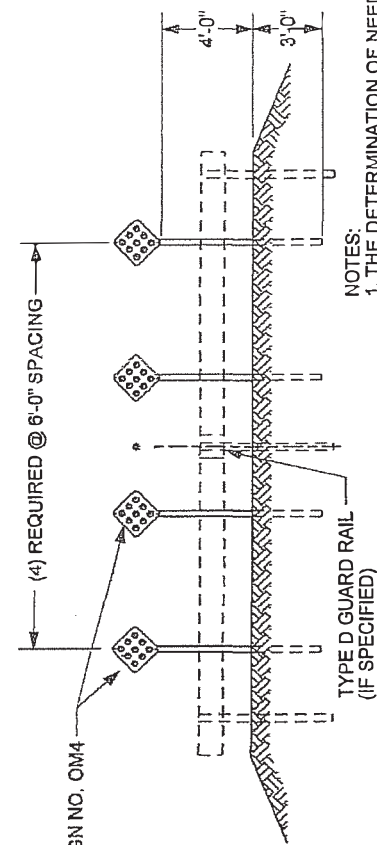

NOTES:
 1. THE DETERMINATION OF NEED OF ANY BARRICADES ASSOCIATED WITH THE CLOSURE OF A PUBLIC ROADWAY WILL BE MADE BY THE STATE REGULATORY AGENCY OR THE PUBLIC ROAD AUTHORITY.

2. TYPE IV BARRICADES ARE TO ONLY BE USED WHEN A PUBLIC ROADWAY IS PERMANENTLY CLOSED TO ROADWAY USERS.
3. IT IS PERMISSIBLE TO UTILIZE A TYPE III BARRICADE WHEN SPECIFIED BY THE STATE REGULATORY AGENCY OR THE PUBLIC ROAD AUTHORITY.
4. WHEN SITE CONDITIONS WARRANT, BARRICADES CAN BE LOCATED OTHER THAN AT RIGHT OF WAY LINE WHEN SPECIFIED BY THE STATE REGULATORY AGENCY OR THE PUBLIC ROAD AUTHORITY.
5. POST MAY BE WOOD OR STEEL WITH ONLY ONE MATERIAL ALLOWED WITHIN A SINGLE PROJECT, EXCEPT FOR END TREATMENTS.
6. ALL DIMENSIONS ARE SUBJECT TO MANUFACTURER'S TOLERANCES EXCEPT WHERE ALLOWABLE TOLERANCES ARE SHOWN.

7. SEE PAGE 2 AND 3 FOR MORE DETAILS.

**UNION PACIFIC RAILROAD
 ENGINEERING STANDARDS**

**TYPE IV BARRICADE FOR
 ROAD CROSSING CLOSURE**

STD DWG	0310
PAGE 1 OF 3	

APPROVED: *Richard J. Conville*
 VP ENGINEERING
 ADOPTED: AUG. 14, 2008
 REVISED:
 FILE NO.: 0310

Copyright © 2008 by Union Pacific Railroad

MOUNTING DETAILS

**TYPE IV OBJECT MARKER - SIGN OM4
 (END OF ROAD OR STREET)**

TYPICAL ROAD CLOSED

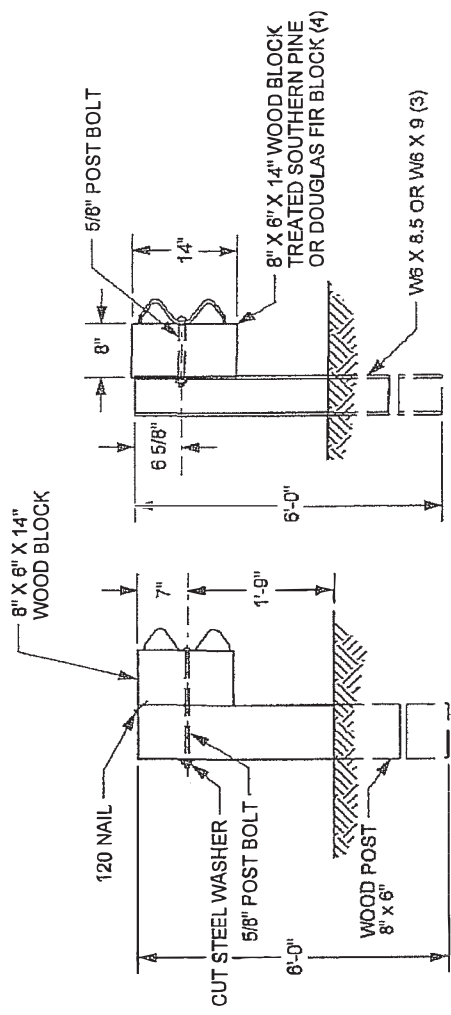

THE CONTRACTOR MAY FURNISH EQUIVALENT SECTIONS FABRICATED FROM MATERIAL MEETING AND IN ACCORDANCE WITH THE REQUIREMENTS OF ASTM A769 GRADE 36 OR 40. THE SECTIONS SHALL BE GALVANIZED AFTER FABRICATION IN ACCORDANCE WITH THE REQUIREMENTS OF AASHTO M111.

STEEL POST & WOOD BLOCK

WOOD POST & BLOCK

STD DWG	0310
PAGE 1 OF 3	

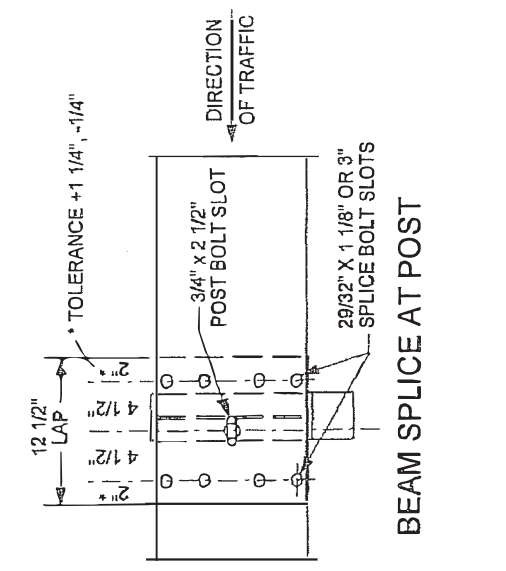

BEAM SPLICE AT POST

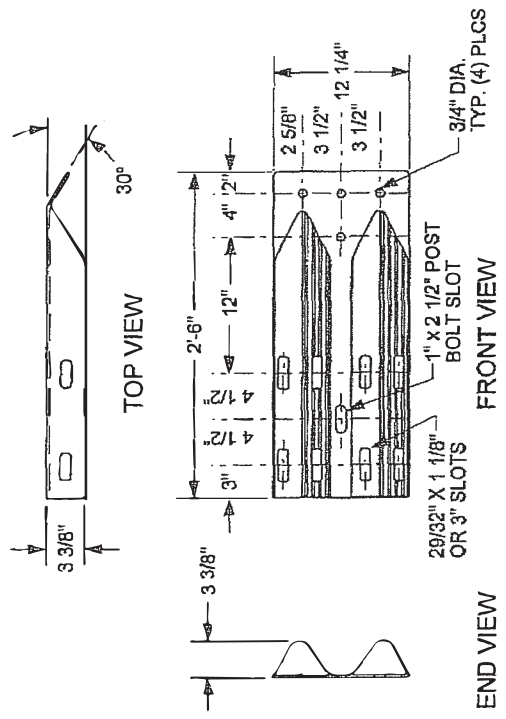

TERMINAL CONNECTOR

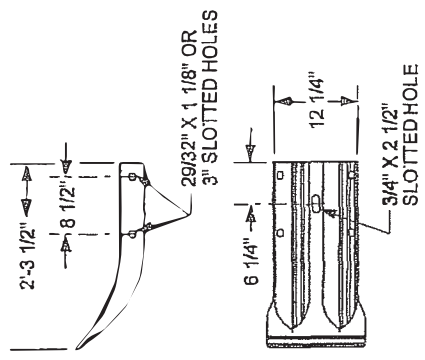

12 GAGE
END SECTION

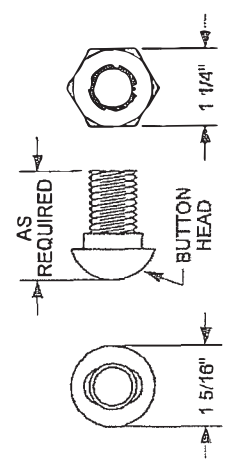

5/16" POST OR SPLICE BOLT
OVAL SHOULDER SHALL BE OF ADEQUATE HEIGHT,
LENGTH & SHAPE TO PREVENT TURNING DURING
INSTALLATION OR REMOVAL OF BOLT.

UNION PACIFIC RAILROAD
ENGINEERING STANDARDS

**TYPE IV BARRICADE FOR
ROAD CROSSING CLOSURE**

APPROVED: *Clayton R. ...*
VP ENGINEERING
ADOPTED: AUG. 14, 2009
REVISED:
FILE NO.: 0310

STD DWG
0310
PAGE 3 OF 3

Copyright © 2009 by Union Pacific Railroad

STD DWG
0310
PAGE 3 OF 3

Contractor's Right of Entry
Projects Form Approved 02/09/2022

Public Project No. 0802086

**CONTRACTOR'S
RIGHT OF ENTRY AGREEMENT**

THIS AGREEMENT is made and entered into as of the _____ day of _____, 20_____, by and between **UNION PACIFIC RAILROAD COMPANY**, a Delaware corporation ("Railroad"); and _____, a _____ corporation ("Contractor").

RECITALS:

Contractor has been hired by _____ to perform work relating to _____ (the "Work") with all or a portion of such Work to be performed on property of Railroad in the vicinity of Railroad's Milepost _____ on Railroad's _____ [Subdivision or Branch] [at or near DOT No. _____ located at or near _____, in _____ County, State of _____, as such location is in the general location shown on the print marked **Exhibit A**, attached hereto and hereby made a part hereof, which Work is the subject of a contract dated _____ between Railroad and _____.

Railroad is willing to permit Contractor to perform the Work described above at the location described above subject to the terms and conditions contained in this agreement

AGREEMENT:

NOW, THEREFORE, it is mutually agreed by and between Railroad and Contractor, as follows:

ARTICLE 1 - DEFINITION OF CONTRACTOR.

For purposes of this agreement, all references in this agreement to Contractor shall include Contractor's contractors, subcontractors, officers, agents and employees, and others acting under its or their authority. For purposes of clarity, Contractor agrees that any CIC (defined below) hired by Contractor is a subcontractor of Contractor and therefore included in the defined term Contractor pursuant to the foregoing sentence.

ARTICLE 2 - RIGHT GRANTED: PURPOSE.

Railroad hereby grants to Contractor the right, during the term hereinafter stated and upon and subject to each and all of the terms, provisions and conditions herein contained, to enter upon and have ingress to and egress from the property described in the Recitals for the purpose of performing the Work described in the Recitals above. The right herein granted to Contractor is limited to those portions of Railroad's property specifically described herein, or as designated by the Railroad Representatives named in Article 4.

ARTICLE 3 - TERMS AND CONDITIONS CONTAINED IN EXHIBITS B AND C.

The terms and conditions contained in **Exhibit B** and **Exhibit C**, attached hereto, are hereby made a part of this agreement.

Contractor's Right of Entry Public
Projects Form Approved 02/09/2022

ARTICLE 4 - ALL EXPENSES TO BE BORNE BY CONTRACTOR: RAILROAD REPRESENTATIVES.

A. Contractor shall bear any and all costs and expenses associated with any Work performed by Contractor (including without limitation any CIC), or any costs or expenses incurred by Railroad relating to this agreement.

B. Contractor shall coordinate all of its Work with the following Railroad representatives or their duly authorized representative (the "Railroad Representatives"):

MTM: _____

PM: _____

C. Contractor, at its own expense, shall adequately police and supervise all Work to be performed by Contractor and shall ensure that such Work is performed in a safe manner as set forth in Section 7 of **Exhibit B**. The responsibility of Contractor for safe conduct and adequate policing and supervision of Contractor's Work shall not be lessened or otherwise affected by Railroad's approval of plans and specifications involving the Work, or by Railroad's collaboration in performance of any Work, or by the presence at the Work site of a Railroad Representative, or by compliance by Contractor with any requests or recommendations made by Railroad Representative.

ARTICLE 5 - SCHEDULE OF WORK ON A MONTHLY BASIS.

The Contractor, at its expense, shall provide on a monthly basis a detailed schedule of Work to the Railroad Representative named in Article 4B above. The reports shall start at the execution of this agreement and continue until this agreement is terminated as provided in this agreement or until the Contractor has completed all Work on Railroad's property.

ARTICLE 6 - TERM: TERMINATION.

A. The grant of right herein made to Contractor shall commence on the date of this agreement, and continue until _____, unless sooner terminated as herein provided, or at such time as Contractor has completed its Work on Railroad's property, whichever is earlier. Contractor agrees to notify the Railroad Representative in writing when it has completed its Work on Railroad's property.

B. This agreement may be terminated by either party on ten (10) days written notice to the other party.

ARTICLE 7 - CERTIFICATE OF INSURANCE.

A. Before commencing any Work and throughout the entire term of this Agreement, Contractor, at its expense, shall procure and maintain in full force and effect the types and minimum limits of insurance specified in **Exhibit C** of this agreement and require each of its subcontractors to include the insurance endorsements as required under Section 12 of **Exhibit B** of this agreement.

B. Not more frequently than once every two (2) years, Railroad may reasonably modify the required insurance coverage to reflect then-current risk management practices in the railroad industry and underwriting practices in the insurance industry.

C. Upon request of Railroad, Contractor shall provide to Railroad a certificate issued by its insurance carrier evidencing the insurance coverage required under **Exhibit B**.

D. Contractor understands and accepts that the terms of this Article are wholly separate from and independent of the terms of any indemnity provisions contained in this Agreement.

Contractor's Right of Entry Public
Projects Form Approved 02/09/2022

E. Upon request of Railroad, insurance correspondence, binders, policies, certificates and endorsements shall be sent to:

Union Pacific Railroad Company

[Insert mailing address]

Attn: _____

Project No. 0802086

ARTICLE 8 - PRECONSTRUCTION MEETING.

If the Work to be performed by the Contractor will involve the Railroad providing any flagging protection (or if a CIC is approved to provide flagging protection pursuant to the terms set forth herein) and/or there is separate work to be performed by the Railroad, the Contractor confirms that no work shall commence until the Railroad and Contractor participate in a preconstruction meeting involving flagging procedures and coordination of work activities of the Contractor and the Railroad (and any CIC, as applicable.) Union Pacific's Third Party Flagging Policy at the link provided here: www.up.com/flagging

ARTICLE 9. DISMISSAL OF CONTRACTOR'S EMPLOYEE.

At the request of Railroad, Contractor shall remove from Railroad's property any employee of Contractor who fails to conform to the instructions of the Railroad Representative in connection with the Work on Railroad's property, and any right of Contractor shall be suspended until such removal has occurred. Contractor shall indemnify Railroad against any claims arising from the removal of any such employee from Railroad's property.

ARTICLE 10. ADMINISTRATIVE FEE.

Upon the execution and delivery of this agreement, Contractor shall pay to Railroad One Thousand Twenty Five Dollars (\$1,025.00) as reimbursement for clerical, administrative and handling expenses in connection with the processing of this agreement.

ARTICLE 11. CROSSINGS: COMPLIANCE WITH MUTCD AND FRA GUIDELINES.

A. No additional vehicular crossings (including temporary haul roads) or pedestrian crossings over Railroad's trackage shall be installed or used by Contractor without the prior written permission of Railroad.

B. Any permanent or temporary changes, including temporary traffic control, to crossings must conform to the Manual of Uniform Traffic Control Devices (MUTCD) and any applicable Federal Railroad Administration rules, regulations and guidelines, and must be reviewed by the Railroad prior to any changes being implemented. In the event the Railroad is found to be out of compliance with federal safety regulations due to the Contractor's modifications, negligence, or any other reason arising from the Contractor's presence on the Railroad's property, the Contractor agrees to assume liability for any civil penalties imposed upon the Railroad for such noncompliance.

ARTICLE 12.- EXPLOSIVES.

Explosives or other highly flammable substances shall not be stored or used on Railroad's property without the prior written approval of Railroad.

Contractor's Right of Entry Public
Projects Form Approved 02/09/2022

IN WITNESS WHEREOF, the parties hereto have duly executed this agreement in duplicate as of the date first herein written.

UNION PACIFIC RAILROAD COMPANY

By: _____

Title: _____

(Name of Contractor)

By: _____

Name: _____

Title: _____

Phone: _____

E-Mail: _____

EXHIBIT A
TO
CONTRACTOR'S RIGHT OF ENTRY AGREEMENT

Exhibit A will be a print showing the general location of the work site.

EXHIBIT "A"

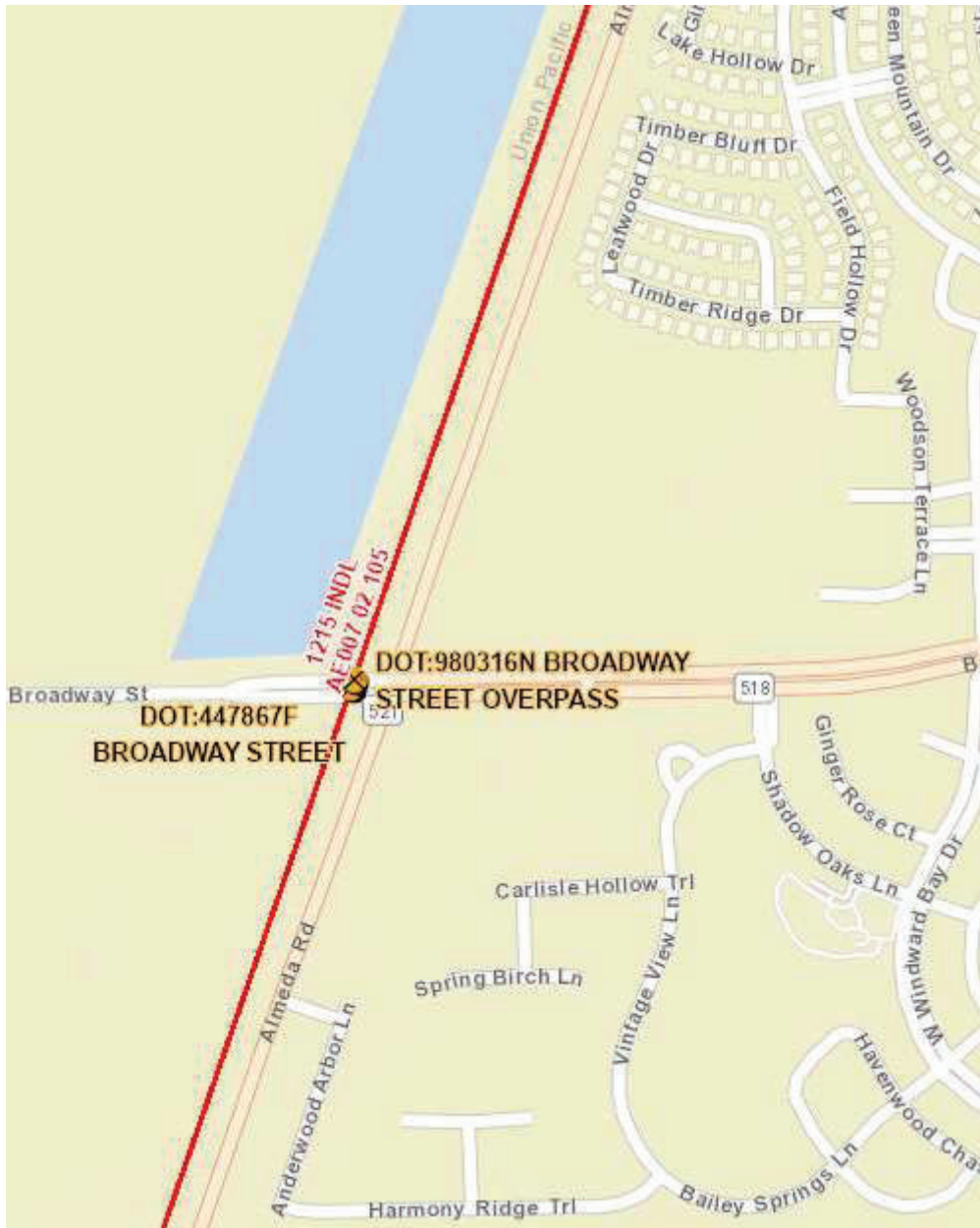
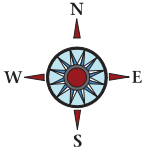

WARNING

IN ALL OCCASIONS, U.P. COMMUNICATIONS DEPARTMENT MUST BE CONTACTED IN ADVANCE OF ANY WORK TO DETERMINE EXISTENCE AND LOCATION OF FIBER OPTIC CABLE.

EXHIBIT "A" UNION PACIFIC RAILROAD COMPANY

SUBDIVISION: Popp Industrial Lead
LICENSEE: TXDOT
RAILROAD MILEPOST: 8.507
Fresno, Fort Bend County, Texas
Project No. 0802086

EXHIBIT B
TO
CONTRACTOR'S RIGHT OF ENTRY AGREEMENT

Section 1. NOTICE OF COMMENCEMENT OF WORK - RAILROAD FLAGGING - PRIVATE FLAGGING.

A. Contractor agrees to notify the Railroad Representative at least ten (10) working days in advance of Contractor commencing its Work and at least thirty (30) working days in advance of proposed performance of any Work by Contractor in which any person or equipment will be within twenty-five (25) feet of any track, or will be near enough to any track that any equipment extension (such as, but not limited to, a crane boom) will reach to within twenty-five (25) feet of any track.

B. No work of any kind shall be performed, and no person, equipment, machinery, tool(s), material(s), vehicle(s), or thing(s) shall be located, operated, placed, or stored within twenty-five (25) feet of any of Railroad's track(s) at any time, for any reason, unless and until a Railroad approved flagman is provided to watch for trains. Upon receipt of such thirty (30)-day notice, the Railroad Representative will determine and inform Contractor whether a flagman need be present and whether Contractor needs to implement any special protective or safety measures.

C. Contractor shall be permitted to hire a private contractor to perform flagging or other special protective or safety measures (such private contractor being commonly known in the railroad industry as a contractor-in-charge ("CIC")) in lieu of Railroad providing such services or in concert with Railroad providing such services, subject to prior written approval by Railroad, which approval shall be in Railroad's sole and absolute discretion. If Railroad agrees to permit Contractor to utilize a CIC pursuant to the preceding sentence, Contractor shall obtain Railroad's prior approval in writing for each of the following items, as determined in all respects in Railroad's sole and absolute discretion: (i) the identity of the third-party performing the role of CIC; (ii) the scope of the services to be performed for the project by the approved CIC; and (iii) any other terms and conditions governing such services to be provided by the CIC. If flagging or other special protective or safety measures are performed by an approved CIC, Contractor shall be solely responsible for (and shall timely pay such CIC for) its services. Railroad reserves the right to rescind any approval pursuant to this Section 1, Subsection C., in whole or in part, at any time, as determined in Railroad's sole and absolute discretion.

D. If any flagging or other special protective or safety measures are performed by employees of Railroad and/or any contractor of Railroad, Railroad will bill Contractor for such expenses incurred by Railroad, unless Railroad and a federal, state or local governmental entity have agreed that Railroad is to bill such expenses to the federal, state or local governmental entity. If Railroad will be sending the bills to Contractor, Contractor shall pay such bills within thirty (30) days of Contractor's receipt of billing.

E. If any flagging or other special protective or safety measures are performed by Railroad or a CIC, Contractor agrees that Contractor is not relieved of any of its responsibilities or liabilities set forth in this agreement.

F. The provisions set forth in this subsection are only applicable for Flagging Services performed by employees of Railroad: the rate of pay per hour for each flagman will be the prevailing hourly rate in effect for an eight-hour day for the class of flagmen used during regularly assigned hours and overtime in accordance with labor agreements and schedules in effect at the time the Work is performed. In addition to the cost of such labor, a composite charge for vacation, holiday, health and welfare, supplemental sickness, Railroad Retirement and unemployment compensation, supplemental pension, Employees Liability and Property Damage and Administration will be included, computed on actual payroll. The composite charge will be the prevailing composite charge in effect at the time the Work is performed. One and one-half times the current hourly rate is

paid for overtime, Saturdays and Sundays, and two and one-half times current hourly rate for holidays. Wage rates are subject to change, at any time, by law or by agreement between Railroad and its employees, and may be retroactive as a result of negotiations or a ruling of an authorized governmental agency. Additional charges on labor are also subject to change. If the wage rate or additional charges are changed, Contractor (or the governmental entity, as applicable) shall pay on the basis of the new rates and charges. If flagging is performed by Railroad, reimbursement to Railroad will be required covering the full eight-hour day during which any flagman is furnished, unless the flagman can be assigned to other Railroad work during a portion of such day, in which event reimbursement will not be required for the portion of the day during which the flagman is engaged in other Railroad work. Reimbursement will also be required for any day not actually worked by the flagman following the flagman's assignment to work on the project for which Railroad is required to pay the flagman and which could not reasonably be avoided by Railroad by assignment of such flagman to other work, even though Contractor may not be working during such time. When it becomes necessary for Railroad to bulletin and assign an employee to a flagging position in compliance with union collective bargaining agreements, Contractor must provide Railroad a minimum of five (5) days notice prior to the cessation of the need for a flagman. If five (5) days notice of cessation is not given, Contractor will still be required to pay flagging charges for the five (5) day notice period required by union agreement to be given to the employee, even though flagging is not required for that period. An additional thirty (30) days notice must then be given to Railroad if flagging services are needed again after such five-day cessation notice has been given to Railroad.

Section 2. LIMITATION AND SUBORDINATION OF RIGHTS GRANTED

A. The foregoing grant of right is subject and subordinate to the prior and continuing right and obligation of the Railroad to use and maintain its entire property including the right and power of Railroad to construct, maintain, repair, renew, use, operate, change, modify or relocate railroad tracks, roadways, signal, communication, fiber optics, or other wirelines, pipelines and other facilities upon, along or across any or all parts of its property, all or any of which may be freely done at any time or times by Railroad without liability to Contractor or to any other party for compensation or damages.

B. The foregoing grant is also subject to all outstanding superior rights (whether recorded or unrecorded and including those in favor of licensees and lessees of Railroad's property, and others) and the right of Railroad to renew and extend the same, and is made without covenant of title or for quiet enjoyment.

Section 3. NO INTERFERENCE WITH OPERATIONS OF RAILROAD AND ITS TENANTS.

A. Contractor shall conduct its operations so as not to interfere with the continuous and uninterrupted use and operation of the railroad tracks and property of Railroad, including without limitation, the operations of Railroad's lessees, licensees or others, unless specifically authorized in advance by the Railroad Representative. Nothing shall be done or permitted to be done by Contractor at any time that would in any manner impair the safety of such operations. When not in use, Contractor's machinery and materials shall be kept at least twenty-five (25) feet from the centerline of Railroad's nearest track, and there shall be no vehicular crossings of Railroads tracks except at existing open public crossings.

B. Operations of Railroad and work performed by Railroad personnel and delays in the Work to be performed by Contractor caused by such railroad operations and Work are expected by Contractor, and Contractor agrees that Railroad shall have no liability to Contractor, or any other person or entity for any such delays. The Contractor shall coordinate its activities with those of Railroad and third parties so as to avoid interference with railroad operations. The safe operation of Railroad train movements and other activities by Railroad takes precedence over any Work to be performed by Contractor.

Section 4. LIENS.

Contractor shall pay in full all persons who perform labor or provide materials for the Work to be performed by Contractor. Contractor shall not create, permit or suffer any mechanic's or materialmen's liens of any kind or nature to be created or enforced against any property of Railroad for any such Work performed. Contractor shall indemnify and hold harmless Railroad from and against any and all liens, claims, demands, costs or expenses of whatsoever nature in any way connected with or growing out of such Work done, labor performed, or materials furnished. If Contractor fails to promptly cause any lien to be released of record, Railroad may, at its election, discharge the lien or claim of lien at Contractor's expense.

Section 5. PROTECTION OF FIBER OPTIC CABLE SYSTEMS.

A. Fiber optic cable systems may be buried on Railroad's property. Protection of the fiber optic cable systems is of extreme importance since any break could disrupt service to users resulting in business interruption and loss of revenue and profits. Contractor shall visit www.up.com/CBUD to complete and submit the required form to determine if fiber optic cable is buried anywhere on Railroad's property to be used by Contractor. If it is, Contractor will telephone the telecommunications company(ies) involved, make arrangements for a cable locator and, if applicable, for relocation or other protection of the fiber optic cable. Contractor shall not commence any Work until all such protection or relocation (if applicable) has been accomplished.

B. IN ADDITION TO OTHER INDEMNITY PROVISIONS IN THIS AGREEMENT, CONTRACTOR SHALL INDEMNIFY, DEFEND AND HOLD RAILROAD HARMLESS FROM AND AGAINST ALL COSTS, LIABILITY AND EXPENSE WHATSOEVER (INCLUDING, WITHOUT LIMITATION, ATTORNEYS' FEES, COURT COSTS AND EXPENSES) ARISING OUT OF ANY ACT OR OMISSION OF CONTRACTOR, ITS AGENTS AND/OR EMPLOYEES, THAT CAUSES OR CONTRIBUTES TO (1) ANY DAMAGE TO OR DESTRUCTION OF ANY TELECOMMUNICATIONS SYSTEM ON RAILROAD'S PROPERTY, AND/OR (2) ANY INJURY TO OR DEATH OF ANY PERSON EMPLOYED BY OR ON BEHALF OF ANY TELECOMMUNICATIONS COMPANY, AND/OR ITS CONTRACTOR, AGENTS AND/OR EMPLOYEES, ON RAILROAD'S PROPERTY. CONTRACTOR SHALL NOT HAVE OR SEEK RECOURSE AGAINST RAILROAD FOR ANY CLAIM OR CAUSE OF ACTION FOR ALLEGED LOSS OF PROFITS OR REVENUE OR LOSS OF SERVICE OR OTHER CONSEQUENTIAL DAMAGE TO A TELECOMMUNICATION COMPANY USING RAILROAD'S PROPERTY OR A CUSTOMER OR USER OF SERVICES OF THE FIBER OPTIC CABLE ON RAILROAD'S PROPERTY.

Section 6. PERMITS - COMPLIANCE WITH LAWS.

In the prosecution of the Work covered by this agreement, Contractor shall secure any and all necessary permits and shall comply with all applicable federal, state and local laws, regulations and enactments affecting the Work including, without limitation, all applicable Federal Railroad Administration regulations.

Section 7. SAFETY.

A. Safety of personnel, property, rail operations and the public is of paramount importance in the prosecution of any Work on Railroad property performed by Contractor. Contractor shall be responsible for initiating, maintaining and supervising all safety, operations and programs in connection with the Work. Contractor shall, at a minimum, comply with Railroad's then current safety standards located at the below web address ("Railroad's Safety Standards") to ensure uniformity with the safety standards followed by Railroad's own forces. As a part of Contractor's safety responsibilities, Contractor shall notify Railroad if Contractor

determines that any of Railroad's Safety Standards are contrary to good safety practices. Contractor shall furnish copies of Railroad's Safety Standards to each of its employees before they enter Railroad property.

http://www.up.com/cs/groups/public/@uprr/@suppliers/documents/up_pdf_natedocs/pdf_up_supplier_safety_req.pdf

B. All personnel employed by the Agency, Contractor and all subcontractors must complete the Railroad's course "Property Access Training" and be registered prior to working on Railroad property. This training is available at www.up.com/up-pat. This training is required to be completed annually.

C. Without limitation of the provisions of paragraph A above, Contractor shall keep the job site free from safety and health hazards and ensure that its employees are competent and adequately trained in all safety and health aspects of the job.

D. Contractor shall have proper first aid supplies available on the job site so that prompt first aid services may be provided to any person injured on the job site. Contractor shall promptly notify Railroad of any U.S. Occupational Safety and Health Administration reportable injuries. Contractor shall have a nondelegable duty to control its employees while they are on the job site or any other property of Railroad, and to be certain they do not use, be under the influence of, or have in their possession any alcoholic beverage, drug or other substance that may inhibit the safe performance of any Work.

E. If and when requested by Railroad, Contractor shall deliver to Railroad a copy of Contractor's safety plan for conducting the Work (the "Safety Plan"). Railroad shall have the right, but not the obligation, to require Contractor to correct any deficiencies in the Safety Plan. The terms of this agreement shall control if there are any inconsistencies between this agreement and the Safety Plan.

Section 8. INDEMNITY.

A. TO THE FULLEST EXTENT ALLOWED BY APPLICABLE LAW, CONTRACTOR SHALL INDEMNIFY, DEFEND AND HOLD HARMLESS RAILROAD, ITS AFFILIATES, AND ITS AND THEIR OFFICERS, AGENTS AND EMPLOYEES (INDIVIDUALLY AN "INDEMNIFIED PARTY" OR COLLECTIVELY "INDEMNIFIED PARTIES") FROM AND AGAINST ANY AND ALL LOSS, DAMAGE, INJURY, LIABILITY, CLAIM, DEMAND, COST OR EXPENSE (INCLUDING, WITHOUT LIMITATION, ATTORNEY'S, CONSULTANT'S AND EXPERT'S FEES, AND COURT COSTS), FINE OR PENALTY (COLLECTIVELY, "LOSS") INCURRED BY ANY PERSON (INCLUDING, WITHOUT LIMITATION, ANY INDEMNIFIED PARTY, CONTRACTOR, OR ANY EMPLOYEE OF CONTRACTOR OR OF ANY INDEMNIFIED PARTY) ARISING OUT OF OR IN ANY MANNER CONNECTED WITH (I) ANY WORK PERFORMED BY CONTRACTOR, OR (II) ANY ACT OR OMISSION OF CONTRACTOR, ITS OFFICERS, AGENTS OR EMPLOYEES, OR (III) ANY BREACH OF THIS AGREEMENT BY CONTRACTOR.

B. THE RIGHT TO INDEMNITY UNDER THIS SECTION 8 SHALL ACCRUE UPON OCCURRENCE OF THE EVENT GIVING RISE TO THE LOSS, AND SHALL APPLY REGARDLESS OF ANY NEGLIGENCE OR STRICT LIABILITY OF ANY INDEMNIFIED PARTY, EXCEPT WHERE THE LOSS IS CAUSED BY THE SOLE ACTIVE NEGLIGENCE OF AN INDEMNIFIED PARTY AS ESTABLISHED BY THE FINAL JUDGMENT OF A COURT OF COMPETENT JURISDICTION. THE SOLE ACTIVE NEGLIGENCE OF ANY INDEMNIFIED PARTY SHALL NOT BAR THE RECOVERY OF ANY OTHER INDEMNIFIED PARTY.

C. CONTRACTOR EXPRESSLY AND SPECIFICALLY ASSUMES POTENTIAL LIABILITY UNDER THIS SECTION 8 FOR CLAIMS OR ACTIONS BROUGHT BY CONTRACTOR'S OWN EMPLOYEES. CONTRACTOR WAIVES ANY IMMUNITY IT MAY HAVE UNDER WORKER'S COMPENSATION OR INDUSTRIAL INSURANCE ACTS TO INDEMNIFY THE INDEMNIFIED PARTIES UNDER THIS SECTION 8.

CONTRACTOR ACKNOWLEDGES THAT THIS WAIVER WAS MUTUALLY NEGOTIATED BY THE PARTIES HERETO.

D. NO COURT OR JURY FINDINGS IN ANY EMPLOYEE'S SUIT PURSUANT TO ANY WORKER'S COMPENSATION ACT OR THE FEDERAL EMPLOYERS' LIABILITY ACT AGAINST A PARTY TO THIS AGREEMENT MAY BE RELIED UPON OR USED BY CONTRACTOR IN ANY ATTEMPT TO ASSERT LIABILITY AGAINST ANY INDEMNIFIED PARTY.

E. THE PROVISIONS OF THIS SECTION 8 SHALL SURVIVE THE COMPLETION OF ANY WORK PERFORMED BY CONTRACTOR OR THE TERMINATION OR EXPIRATION OF THIS AGREEMENT. IN NO EVENT SHALL THIS SECTION 8 OR ANY OTHER PROVISION OF THIS AGREEMENT BE DEEMED TO LIMIT ANY LIABILITY CONTRACTOR MAY HAVE TO ANY INDEMNIFIED PARTY BY STATUTE OR UNDER COMMON LAW.

Section 9. RESTORATION OF PROPERTY.

In the event Railroad authorizes Contractor to take down any fence of Railroad or in any manner move or disturb any of the other property of Railroad in connection with the Work to be performed by Contractor, then in that event Contractor shall, as soon as possible and at Contractor's sole expense, restore such fence and other property to the same condition as the same were in before such fence was taken down or such other property was moved or disturbed. Contractor shall remove all of Contractor's tools, equipment, rubbish and other materials from Railroad's property promptly upon completion of the Work, restoring Railroad's property to the same state and condition as when Contractor entered thereon.

Section 10. WAIVER OF DEFAULT.

Waiver by Railroad of any breach or default of any condition, covenant or agreement herein contained to be kept, observed and performed by Contractor shall in no way impair the right of Railroad to avail itself of any remedy for any subsequent breach or default.

Section 11. MODIFICATION - ENTIRE AGREEMENT.

No modification of this agreement shall be effective unless made in writing and signed by Contractor and Railroad. This agreement and the exhibits attached hereto and made a part hereof constitute the entire understanding between Contractor and Railroad and cancel and supersede any prior negotiations, understandings or agreements, whether written or oral, with respect to the Work to be performed by Contractor.

Section 12. ASSIGNMENT - SUBCONTRACTING.

Contractor shall not assign or subcontract this agreement, or any interest therein, without the written consent of the Railroad. Contractor shall be responsible for the acts and omissions of all subcontractors. Before Contractor commences any Work, the Contractor shall, except to the extent prohibited by law; (1) require each of its subcontractors to include the Contractor as "Additional Insured" on the subcontractor's Commercial General Liability policy and Umbrella or Excess policies (if applicable) with respect to all liabilities arising out of the subcontractor's performance of Work on behalf of the Contractor by endorsing these policies with ISO Additional Insured Endorsements CG 20 10, and CG 20 37 (or substitute forms providing equivalent coverage; (2) require each of its subcontractors to endorse their Commercial General Liability Policy with "Contractual Liability Railroads" ISO Form CG 24 17 10 01 (or a substitute form providing equivalent coverage) for the job site; and (3) require each of its subcontractors to endorse their Business Automobile Policy with "Coverage For Certain Operations In Connection With Railroads" ISO Form CA 20 70 10 01 (or a substitute form providing equivalent coverage) for the job site.

EXHIBIT C
TO
CONTRACTOR'S
RIGHT OF ENTRY AGREEMENT

Union Pacific Railroad Company
Insurance Requirements For
Contractor's Right of Entry Agreement

During the entire term of this Agreement and course of the Project, and until all Project Work on Railroad's property has been completed and all equipment and materials have been removed from Railroad's property and Railroad's property has been clean and restored to Railroad's satisfaction, Contractor shall, at its sole cost and expense, procure and maintain the following insurance coverage:

- A. Commercial General Liability insurance.** Commercial general liability (CGL) with a limit of not less than \$5,000,000 each occurrence and an aggregate limit of not less than \$10,000,000. CGL insurance must be written on ISO occurrence form CG 00 01 12 04 (or a substitute form providing equivalent coverage).

The policy must also contain the following endorsement, which must be stated on the certificate of insurance:

- Contractual Liability Railroads ISO form CG 24 17 10 01 (or a substitute form providing equivalent coverage) showing "Union Pacific Railroad Company Property" as the Designated Job Site.
- Designated Construction Project(s) General Aggregate Limit ISO Form CG 25 03 03 97 (or a substitute form providing equivalent coverage) showing the project on the form schedule.

- B. Business Automobile Coverage insurance.** Business auto coverage written on ISO form CA 00 01 10 01 (or a substitute form providing equivalent liability coverage) with a combined single limit of not less \$5,000,000 for each accident and coverage must include liability arising out of any auto (including owned, hired and non-owned autos).

The policy must contain the following endorsements, which must be stated on the certificate of insurance:

- Coverage For Certain Operations In Connection With Railroads ISO form CA 20 70 10 01 (or a substitute form providing equivalent coverage) showing "Union Pacific Property" as the Designated Job Site.
- Motor Carrier Act Endorsement - Hazardous materials clean up (MCS-90) if required by law.

- C. Workers' Compensation and Employers' Liability insurance.** Coverage must include but not be limited to:

- Contractor's statutory liability under the workers' compensation laws of the state where the Work is being performed.
- Employers' Liability (Part B) with limits of at least \$500,000 each accident, \$500,000 disease policy limit \$500,000 each employee.

If Contractor is self-insured, evidence of state approval and excess workers compensation coverage must be provided. Coverage must include liability arising out of the U. S. Longshoremen's and Harbor Workers' Act, the Jones Act, and the Outer Continental Shelf Land Act, if applicable.

- D. Railroad Protective Liability insurance.** Contractor must maintain "Railroad Protective Liability" (RPL) insurance written on ISO occurrence form CG 00 35 12 04 (or a substitute form providing equivalent coverage) on behalf of Railroad as named insured, with a limit of not less than \$2,000,000 per occurrence

and an aggregate of \$6,000,000. The definition of "JOB LOCATION" and "WORK" on the declaration page of the policy shall refer to this agreement and shall describe all WORK or OPERATIONS performed under this agreement. Contractor shall provide this agreement to Contractor's insurance agent(s) and/or broker(s) and Contractor shall instruct such agent(s) and/or broker(s) to procure the insurance coverage required by this agreement. A BINDER STATING THE POLICY IS IN PLACE MUST BE SUBMITTED TO RAILROAD BEFORE THE WORK MAY COMMENCE AND UNTIL THE ORIGINAL POLICY IS FORWARDED TO UNION PACIFIC RAILROAD.

- E. Umbrella or Excess** insurance. If Contractor utilizes umbrella or excess policies, these policies must "follow form" and afford no less coverage than the primary policy.
- F. Pollution Liability** insurance. Pollution liability coverage must be included when the scope of the Work as defined in the agreement includes installation, temporary storage, or disposal of any "hazardous" material that is injurious in or upon land, the atmosphere, or any watercourses; or may cause bodily injury at any time.

If required, coverage may be provided in separate policy form or by endorsement to Contractors CGL or RPL. Any form coverage must be equivalent to that provided in ISO form CG 24 15 "Limited Pollution Liability Extension Endorsement" or CG 28 31 "Pollution Exclusion Amendment" with limits of at least \$5,000,000 per occurrence and an aggregate limit of \$10,000,000.

If the scope of Work as defined in this agreement includes the disposal of any hazardous or non-hazardous materials from the job site, Contractor must furnish to Railroad evidence of pollution legal liability insurance maintained by the disposal site operator for losses arising from the insured facility accepting the materials, with coverage in minimum amounts of \$1,000,000 per loss, and an annual aggregate of \$2,000,000.

Other Requirements

- G.** All policy(ies) required above (except business automobile, worker's compensation and employers liability) must include Railroad as "Additional Insured" using ISO Additional Insured Endorsements CG 20 10, and CG 20 37 (or substitute forms providing equivalent coverage). The coverage provided to Railroad as additional insured shall not be limited by Contractor's liability under the indemnity provisions of this agreement. BOTH CONTRACTOR AND RAILROAD EXPECT THAT UNION PACIFIC RAILROAD COMPANY WILL BE PROVIDED WITH THE BROADEST POSSIBLE COVERAGE AVAILABLE BY OPERATION OF LAW UNDER ISO ADDITIONAL INSURED FORMS CG 20 10 AND CG 20 37.
- H.** Punitive damages exclusion, if any, must be deleted (and the deletion indicated on the certificate of insurance), unless (a) insurance coverage may not lawfully be obtained for any punitive damages that may arise under this agreement, or (b) all punitive damages are prohibited by all states in which this agreement will be performed.
- I.** Contractor waives all rights of recovery, and its insurers also waive all rights of subrogation of damages against Railroad and its agents, officers, directors and employees for damages covered by the workers compensation and employers liability or commercial umbrella or excess liability obtained by Contractor required in this agreement where prohibited by law. This waiver must be stated on the certificate of insurance.
- J.** Prior to commencing the Work, Contractor shall furnish Railroad with a certificate(s) of insurance, executed by a duly authorized representative of each insurer, showing compliance with the insurance requirements in this agreement.

- K.** All insurance policies must be written by a reputable insurance company acceptable to Railroad or with a current Best's Insurance Guide Rating of A- and Class VII or better, and authorized to do business in the state where the Work is being performed.
- L.** The fact that insurance is obtained by Contractor or by Railroad on behalf of Contractor will not be deemed to release or diminish the liability of Contractor, including, without limitation, liability under the indemnity provisions of this agreement. Damages recoverable by Railroad from Contractor or any third party will not be limited by the amount of the required insurance coverage.