

**CHANGE ORDER**

**FORT BEND COUNTY**

301 Jackson St., Richmond, TX 77469

Phone: 281-633-7510

Fax: 281-342-7366

Web site: www.FortBendCountyTx.gov

Distribution:

- FBC Parks
- FBC Judge
- FBC Purchasing
- Contractor
- Consultant

**PROJECT:**  
**Construction of Mustang Park Community Center**  
**Renovation and New**  
**Construction in Precinct Two**  
**Bid No. 25-067**

CHANGE ORDER NUMBER:..... 1  
 DATE:..... 12/25/2025  
 BID NUMBER: ..... 25-067  
 CONTRACT FOR:Construction of Mustang Park Community Center Renovation and New Construction  
 CONTRACT DATE: ..... 8/12/2025  
 FBC PURCHASE ORDER NO. .... 261435

**CONTRACTOR:**  
 Patriot Contracting, LLC  
 300 Shepherd Dr. Suite A  
 Houston, Texas 77007

The contract is changed as follows:

- 1 -The change order is a result of ASI #001 – Electrical design for services related to the proposed pump pit/lift station. The items include electrical scope of work for ASI 1 – providing power to pumps.
- 2 – Existing kitchen ceiling needs to demolished and reframed to accommodate the newly installed HVAC system and ductwork. Current set up will not be feasible for new construction. – per RFI 22

**Not valid until signed by Fort Bend County and Contractor.**

The Original (Contract Sum)..... \$ 19,405,561.50  
 Net change by previously authorized Change orders ..... \$ 0.00  
 The (Contract Sum) Prior to this Change Order was ..... \$ 19,405,561.50  
 The (Contract Sum) will be increased by this Change Order in the amount of..... \$ 28,102.62  
 The new (Contract Sum) including this Change Order will be ..... \$ 19,433,664.12  
 The Contract Time will be Increased by 25 Calendar days.  
 The Date of Substantial Completion as of this Change Order therefore is November 22, 2026.

Authorized:

**Hines AD LLC**  
 2617 Bissonnet Ste 219  
 Houston, Texas 77005

**Patriot Contracting, LLC**  
 300 Shepherd Dr. Suite A  
 Houston, Texas 77007

**Fort Bend County Judge**  
 Honorable KP George  
 301 Jackson St., #719  
 Richmond, Texas 77469

By: Antonio Perez  
 (signature)  
 DATE: 2/25/2026

By:   
 (signature)  
 DATE: 2/25/2026

By: \_\_\_\_\_  
 (signature)  
 DATE: \_\_\_\_\_

## Change Proposal - Contractor's Estimate

<b>Dated</b>	<b>Friday, February 6, 2026</b>		<b>CPR NO.</b>	<b>1</b>	<b>Electric Work for Lift Station and Kitchen Ceiling Rework</b>
			<b>PROJECT</b>		
	<b>Pathfinder</b>	<b>Phoenix</b>	<b>Fort Bend County Mustang Park</b>		
<b>Subcontractor Cost</b>					
Material	\$ 6,500.00	\$ 5,765.45			
Labor	\$ 1,200.00	\$ 8,648.19			
Equipment	\$ 2,180.00	\$ -			
Subtotal	\$ 9,880.00	\$ 14,413.64			
Subcontractor's Overhead & Profit		\$ 1,441.36			
<b>Total Cost for Subcontractor</b>	<b>\$ 9,880.00</b>	<b>\$ 15,855.00</b>			<b>\$ 25,735.00</b>
<b>General Contractor Cost</b>					
Material	\$ -	\$ -			
Labor	\$ -	\$ -			
Equipment	\$ -	\$ -			
Subtotal	\$ -	\$ -			
General Contractor Overhead & Profit (10%)			\$ -		
Subtotal General Contractor Cost			\$ -		
GC's Subcontractor Overhead & Profit (5%)			\$ 1,286.75		
<b>Total Cost for General Contractor</b>					<b>\$ 1,286.75</b>
<b>Subtotal Cost for General Contractor &amp; Subcontractor</b>					<b>\$ 27,021.75</b>
<b>Bond &amp; Insurance (GC Only)</b>					
Cost of Insurance	1%		\$ 270.22		
Cost of Payment & Performance Bonds	3%		\$ 810.65		
<b>Total Cost for Change Proposal</b>					<b>\$ 28,102.62</b>
<b>TIME EXTENSION IN DAYS (FOR THIS CHANGE)</b>			<b>25</b>		
<b>7 Weather Days since October 2025</b>					

<i>Ted Tou</i>	<b>Dated</b>	<b>2/6/2026</b>
<b>General Contractor Signature</b>		
<i>Antonio Perez</i>	<b>Dated</b>	<b>2/25/2026</b>
<b>Hines A&amp;D - Approval Signature</b>		
<b>Fort Bend County - Approval Signature</b>	<b>Dated</b>	



**Mustang Park Community Center  
4521 FM 521 Fresno, TX 77545**

**Submitted by: Pathfinder Services**

**Date: July OCT 31 , 2025**

**Pathfinder Project #: 1-255116**

**ASI 1**

**To: Patriot Contracting LLC**

**Attention: Estimating Department**

Dear Valued Client,

Pathfinder Services is pleased to submit this proposal for the electrical scope of work for ASI 1 – providing power to pumps

### **Scope of Work**

- **ASI 1**
- New 60 AMP circuit from panel 2N2
- Provide and install new 60 AMP outdoor panel at pump location
- Provide and install two 20 AMP circuits to pump control box “ pumps and control by others
- Provide 350” trench
- Provide and install Generator bypass plug
- Provide and install 60 AMP breaker
- Provide handhole junction box
- **Exclusions**

The following items are excluded from this proposal:

11831 Fairmont Pkwy LaPorte TX 77551  
346-571-6610  
Website: [www.pathfindersvcs.com](http://www.pathfindersvcs.com)



- Performance and payment bonds (add 3% to total cost if required).
- Builder's Risk insurance and associated deductibles.
- Low-voltage cabling, wiring, HVAC controls, and data systems.
- Any and all Fire Alarm
- All concrete work, including pole bases, curbs for transformers, and gear.
- Generators and temporary power infrastructure.
- Innerduct and concrete for duct banks (not specified in plans).
- All electrical equipment (panels, gear, bus gutters, and lighting) provided by others.
- All overtime for accelerated schedule.
- Concrete for pole bases and transformer Pad. Generator pad or ballads

**Note:** Any changes to the scope of work outlined in this proposal will require a written change order, signed by both parties, to address cost and schedule impacts prior to execution.

### **Pricing**

**With VE lighting package Total Lump Sum Cost: \$9,880.00**

**Material \$6500**

**Equipment \$1200**

**Labor \$2180**

- Payment terms: Net 30 days from invoice date.

### **Contract Terms and Conditions**

All work will be performed in accordance with the Master Service Agreement (MSA) between **Patriot Contracting LLC** and Pathfinder Services. The clarifications and assumptions in this proposal shall take precedence over conflicting documents.

### **Proposal Validity**

This proposal is valid for 30 days from the date of submission, unless otherwise

11831 Fairmont Pkwy LaPorte TX 77551  
346-571-6610  
Website: [www.pathfindersvcs.com](http://www.pathfindersvcs.com)



negotiated.

**Contact Information**

We appreciate the opportunity to partner with **Patriot Contracting LLC** on this project.

For questions, clarifications, or to issue a purchase order, please contact:

**George Irwin**

Pathfinder Services

Email: [girwin@pathfindersvcs.com](mailto:girwin@pathfindersvcs.com)

Phone: (832) 506-7514

Purchase Orders: [po@pathfindersvcs.com](mailto:po@pathfindersvcs.com)

We look forward to your acceptance of this proposal and to delivering a successful project that meets your expectations.

Sincerely,

George Irwin

Pathfinder Services Acceptance

By signing below, **Patriot Contracting LLC** accepts the terms and conditions of this

proposal: Name (Print): \_\_\_\_\_

Signature: \_\_\_\_\_

Date: \_\_\_\_\_

## Ted Tou

---

**From:** Gregory Lake <gregory.lake@hinesad.com>  
**Sent:** Tuesday, October 21, 2025 3:24 PM  
**To:** Ted Tou; Elton Allemang  
**Cc:** Brice Anderson; Antonio Perez; Llarance Turner; Climmons, Gwendolyn  
**Subject:** Mustang Park - ASI #001\_Pump Pit/Lift Station  
**Attachments:** Mustang Park - ASI #001\_10212025.pdf

ASI #001 - Electrical design for services related to the proposed pump pit / lift station.

Ted, as discussed this morning, we understand that neither Patriot nor the subcontractor carried any cost for this scope due to the need for clarification in the original construction documents as indicated on E102. With this ASI now issued to provide clarification to this scope, please have the subcontractor review and provide a price proposal for our evaluation and subsequent owner approval.

Ted, we understand that your leadership team had some reservations regarding this matter; we trust that this clarification provides the assurance needed for Patriot to proceed confidently with construction.

Thank you for your patience,  
Gregory

**Gregory L. Lake, AIA**

PRINCIPAL

**HINES ARCHITECTURE+DESIGN**  
8 GREENWAY PLAZA, SUITE 1525 | HOUSTON, TX 77046 USA  
PH 713 909 0983 C 832 405 4412  
[www.hinesad.com](http://www.hinesad.com)

**CONFIDENTIALITY CAUTION:** This message contains information from the company that may be proprietary, confidential and/or privileged. The information is intended only for the use of the individual or entity to whom it is addressed. If you are not the intended recipient, please notify us immediately by return e-mail, delete this message and you should not disseminate, distribute or copy any information contained herein.

# Mustang Park Lighting Fixture Schedule

Date: March 13, 2025

Fixture Type	Manufacturer	Catalog Number	Wattage	Mounting	Voltage	Dimming Type	Description
A1	DAY-BRITE	2FPZ30LCT4DSUNVDIM	23W	RECESSED	UNV	0-10V	2'x4' FLAT PANEL
A1X	SAME AS TYPE A1 WITH EMERGENCY BATTERY PACK						
A2	DAY-BRITE	2FPZ30LCT2DSUNVDIM	23W	RECESSED	UNV	0-10V	2'x2' FLAT PANEL
A2X	SAME AS TYPE A2 WITH EMERGENCY BATTERY PACK						
A3	DAY-BRITE	2FGXG48L9XX4FUNVDIM	36W	RECESSED	UNV	0-10V	2'x4' FLUXGRID
A3X	SAME AS TYPE A3 WITH EMERGENCY BATTERY PACK						
A4	DAY-BRITE	2FGXG38L9XX2FUNVDIM	28.2W	RECESSED	UNV	0-10V	2'x2' FLUXGRID
A4X	SAME AS TYPE A4 WITH EMERGENCY BATTERY PACK						
A5	DAY-BRITE	2FGXG74L9XX4FUNVDIM	56W	RECESSED	UNV	0-10V	2'x4' FLUXGRID HO
A6	DAY-BRITE	2FPZ74LCT4DSUNVDIM/FMA	58W	RECESSED	UNV	0-10V	2'x4' FLAT PANEL HO KITCHEN
A7	DAY-BRITE	2FPZ30LCT2DSUNVDIM/FMA	23W	RECESSED	UNV	0-10V	2'x2' FLAT PANEL HO KITCHEN
A7X	SAME AS TYPE A7 WITH EMERGENCY BATTERY PACK						
BL1	LEDCON	FB-1224-Z-M-O-26W+DRIVER	13W / S.F.	RE: DETAIL	UNV	0-10V	BACK LIGHT SYSTEM FOR CANOPY PERIMETER SYSTEM
C1	LEDALITE	4908L9X22QSN-LENGTH-DE1N1NNWCC4S1	4.875W/FT	RECESSED	UNV	0-10V	WALL MOUNTED PERIMETER, RE: PLANS FOR PATTERN
C2	KLUS	B5554-W-LC-35-1275/2-24-LENGTH-GIP-STN-90-24-72-IP20+ULTRA DRIVER	4.4W/FT	WALL	UNV	0-10V	TYPICAL MODULYTE DOWNLIGHT
D1	LIGHTOLIER	4RNSR/M4RDL259CSWCDZ10U	20.4W	RECESSED	UNV	0-10V	TYPICAL MODULYTE DOWNLIGHT - IN OUTDOOR SDOFIT
D1X	SAME AS TYPE D1 WITH EMERGENCY BATTERY PACK						
D2	LIGHTOLIER	4RNSR/M4RDL109CSWCDZ10U	10.7W	RECESSED	UNV	0-10V	NATATORIUM DOWNLIGHT
D2X	SAME AS TYPE D2 WITH EMERGENCY BATTERY PACK						
D3	KIRLIN	LRR-04105/2000L/CCT/NAT	20.1W	RECESSED	UNV	0-10V	LOCKER ROOM DOWNLIGHT IN NATATORIUM
D3X	SAME AS TYPE D3 WITH EMERGENCY BATTERY PACK						
D4	LIGHTOLIER	4RNSR/M4RDL259CSWCDZ10U	20.4W	RECESSED	UNV	0-10V	REMODEL IC DOWNLIGHT AT EXTERIOR WOOD CANOPY
D4X	SAME AS TYPE D4 WITH EMERGENCY BATTERY PACK						
D5	VISUAL COMFORT	E3SRF-LO9306AI-UNV/E3SFB-HZ	11W	RECESSED	UNV	UNV	WALL MOUNTED EGRESS LIGHT
E1	WE-EF	131-0184-RALXXX	15.8W	WALL	UNV	0-10V	LINEAR GRAZER AT METAL SCREEN - 24" LENGTH
E1X	SAME AS TYPE E1 WITH EMERGENCY BATTERY PACK						
ES1	ACOLYTE	MINI-80-AC-24-35-10x60+ARMORMNT1422+MINISHLD605	18W	SURFACE	UNV	0-10V	LINEAR GRAZER AT METAL SCREEN - 36" LENGTH
ES2	ACOLYTE	MINI-80-AC-36-35-10x60+ARMORMNT1422+MINISHLD900	27W	SURFACE	UNV	0-10V	WALL SCONCE AT CANOPY AREA
ES3	HK LIGHTING	ZXL16-WM-SQ/NF/JUNV/10/30/57/PH/FINISH/SOL	10W	WALL	120V	PHASE	EXTERIOR LINEAR AT CANOPY DETAIL
EL1	BEULUX	JF04-SL-A-L460-IP66-CT30-EC-MC-LENGTH+0-10V DRIVER	4.27W/FT	RE: DETAIL	UNV	0-10V	CHAIN HUNG UTILITY STRIP
H1	DAY-BRITE	FSSSEZ440LCTUNVDIM/FR-126	32.9W	SUSPENDED	UNV	0-10V	CHAIN HUNG UTILITY STRIP - BLACK FINISH
H1X	SAME AS TYPE H1 WITH EMERGENCY BATTERY PACK						
H2	DAY-BRITE	FSS440LCTUNVDIMBK/FR-126	29.9W	SUSPENDED	UNV	0-10V	CHAIN HUNG SEALED UTILITY STRIP
H2X	SAME AS TYPE H2 WITH EMERGENCY BATTERY PACK						
H3	DAY-BRITE	FSX440LCTUNVDIM/FR-126	32W	SUSPENDED	UNV	0-10V	CHAIN HUNG NATATORIUM RATED STRIP
H3X	SAME AS TYPE H3 WITH EMERGENCY BATTERY PACK						
H4	KENALL	MLHA5-48-F-MW-PP-45LXXK-DCC-DV-NAT	49W	SUSPENDED	UNV	0-10V	STAKE MOUNTED PATH LIGHT ON LOW VOLTAGE TRANSFORMER
H4X	SAME AS TYPE H4 WITH EMERGENCY BATTERY PACK						
L1	HK LIGHTING	ZPLLT-OS1-ABX-012V-03W-30-24-MH02-12-BRZ	3W	STAKE	12V		TREE MOUNT MOON LIGHT(UTILIZE LIQUID TIGHT FLEXABLE CONDUIT)
L2	HK LIGHTING	ZXL30-IR1-S-B-ABR-120V-21W-30K-W+GSL+TM07-JBS-JBT	21W	TREE	120V	PHASE	STAKE MOUNT TREE UPLIGHT WITH ADJUSTABLE OPTIC
L3	HK LIGHTING	ZXA16-IR1SG-ABX-120V07W-30A-MHJB-12-BRZ	7W	STAKE	120V	PHASE	STAKE MOUNTED SIGN LIGHT
L4	RAYHIL	ARK-4-30-UNV-OF-50-FINISH+ARK-AAGL-4FT+ARK-PL-XX"+ARK-MSL	36W	STAKE	UNV	N/A	INGRADE FIXTURE WITH REMOTE DRIVER
L5	FILIX	RDD100-TM-H-GX-24-6+DRIVER	10W	IN-GRADE	UNV		BOLLARD
L6	ARCLUCE	0864000D-830-12US	26W	BASE	UNV	0-10V	LINEAR IN-GRADE
L7	BEULUX	PH02-B-C-F-L780-IP66-CT30-EC-LENGTH+0-10V DRIVER	6.72W / FT	RE: DETAIL	UNV	0-10V	AREA HEAD - TYPE 3 DISTRIBUTION
L8A	GARDCO	OPF-S/P09/830/T4M/AR1/UNV/BK + L/SRS-CB-5-11-30-D1-BK	133W	POLE	UNV	0-10V	AREA HEAD - TYPE 4 DISTRIBUTION, DUAL MOUNT
L8B	GARDCO	(2) OPF-S/P09/830/T4M/AR1/UNV/BK + L/SRS-CB-5-11-30-D2-BK	133W	POLE	UNV	0-10V	AREA HEAD - TYPE 4 DISTRIBUTION
L8C	GARDCO	OPF-S/P09/830/T4M/AR1/UNV/BK + L/SRS-CB-5-11-30-D1-BK	133W	POLE	UNV	0-10V	STAKE MOUNTED FLAG UPLIGHT
L9	WE-EF	139-2032/RALXXX+270-9038+139-1987	29W	SHORT POST	UNV	0-10V	LINEAR PENDANT WITH ROW CONNECTOR
LP1	DAY-BRITE	FLP8100L9XXQUNVDIM+FLP-J+HCH10-VHOOK	67.9W	SUSPENDED	UNV	0-10V	LINEAR PENDANT AT FITNESS ①
LP1X	SAME AS TYPE LP1 WITH EMERGENCY BATTERY PACK						
LP2	AMERICAN LINEAR	2S-24FT-MD-35-UNV-JB-FINISH-C90-CB144	160.56W	SUSPENDED	UNV	0-10V	LINEAR PENDANT AT NATATORIUM - RE: PLAN FOR PATTERN
LP2X	SAME AS TYPE LP2 WITH EMERGENCY BATTERY PACK						
LP3	AXIS LIGHTING	EXPD-1000-90-30-ASO-PATTERN-AP-UNV-DP-1+E(4)-SASL(X")+N	9.8W / FT	SUSPENDED	UNV	0-10V	PENDANT - RING
LP3X	SAME AS TYPE LP3 WITH EMERGENCY BATTERY PACK						
P1	TECHOLED	HALO-D-35-ME-35-U-FINISH-P-DM-X	50W	SUSPENDED	UNV	0-10V	3D PRINTED CYLINDER
P1X	SAME AS TYPE P1 WITH EMERGENCY BATTERY PACK						
P2	LIGHTOLIER	3DP ICY3-CLR-LF-15L-VWB-35K-CC-DI-XXXX	13.5W	SUSPENDED	UNV	0-10V	THEATRICAL FIXTURE TYPE 1
T1	ETC	CSSPOTJR2550/OTB-FH/OTB-PTP/400SC	166W	TRACK	120V	DMX	THEATRICAL FIXTURE TYPE 2
T2	ETC	CSPAR/SELRM-D22/OTB-FH/OTB-PTP/400SC	90W	TRACK	120V	DMX	TRACK & BACKBONE FOR THEATRICAL FIXTURES, SUSPENDED WITH RIGID
TRK	ETC	OT08-277/OT12-277+OT-SC+OT-CAP+OT-DMXT+OTB-8/12+OTB-LJ+OTB-EF+OTB-EC		SUSPENDED	120V	N/A	EXIT SIGN - SINGLE SIDED
X1	EMERGI-LITE	TA-PEN-F-1-RM	1.5W	AS REQ'D	UNV	N/A	EXIT SIGN - DOUBLE SIDED
X2	EMERGI-LITE	TA-PEN-F-2-RM	1.5W	AS REQ'D	UNV	N/A	EXIT SIGN - WET AREA
XW	EMERGI-LITE	BA-SVXN-X-R-4X	1.2W	AS REQ'D	UNV	N/A	

## LIGHTING GENERAL NOTES:

- CONTRACTOR SHALL LOCATE ALL SITE LIGHTING REMOTE DRIVERS AND 12/24V TRANSFORMERS IN COMMUNITY CENTER BUILDING AND UPSIZE CONDUCTORS FOR VOLTAGE DROP PER MANUFACTURES REQUIREMENTS.

## LIGHTING NOTES:

- PROVIDE ONE FOUR FOOT SECTION WITH BATTERY PACK PER FLOOR PLANS.

## ELECTRICAL SYMBOLS LEGEND

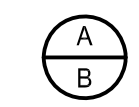

DETAIL/SECTION IDENTIFICATION: A = DETAIL/SECTION LETTER, B = SHEET NUMBER WHERE DETAIL/SECTION IS DRAWN.

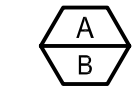

EQUIPMENT CONNECTION CALLOUT. A,B EQUAL EQUIPMENT IDENTIFICATION ON MECHANICAL OR KITCHEN EQUIPMENT CONNECTION SCHEDULES. VERIFY EXACT EQUIPMENT REQUIREMENTS ON SHOP DRAWING EQUIPMENT SUBMITTALS PRIOR TO ROUGH-IN. DO NO ROUGH-IN FOR EQUIPMENT PRIOR TO REVIEW OF SUBMITTALS. REPORT ANY DIFFERENCES IN REQUIREMENTS TO ENGINEER IN WRITING.

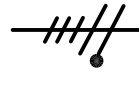

CONDUIT CONCEALED. HASH MARKS INDICATE NUMBER OF #12 CONDUCTORS IN CODE SIZE CONDUIT. NO HASH MARKS INDICATES 2-#12 CONDUCTORS PLUS GROUND IN 3/4" CONDUIT, LONG HASH MARKS INDICATES NEUTRAL CONDUCTOR. ✓ INDICATES GROUND CONDUCTOR.



FLEXIBLE RACEWAY, PROVIDE GROUND CONDUCTORS PER NEC.

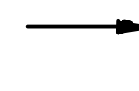

A-1.3 ADJACENT TO ARROW INDICATES HOMERUN OF CONDUCTORS IN CONDUIT FOR CIRCUITS 1 AND 3 TO PANEL "A".



EXIT LIGHT WITH BATTERY, UNIVERSAL MOUNTING.



LED LIGHT FIXTURE, SURFACE MOUNTED ON CEILING.



LED LIGHT FIXTURE, RECESS MOUNTED IN CEILING.



LED LIGHT FIXTURE, WITH EMERGENCY BATTERY PACK.

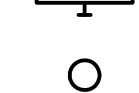

LED LIGHT FIXTURE, WALL MOUNTED.

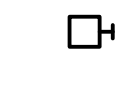

LED DOWNLIGHT FIXTURE.



LED WALL MOUNT LIGHT FIXTURE.

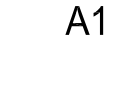

LIGHT TRACK. QUANTITY OF FIXTURES AS INDICATED.



JUNCTION BOX.

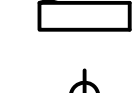

LIGHT FIXTURE TYPE. A1 = SPECIFIC LIGHTING FIXTURE REFERENCED ON LIGHTING FIXTURE SCHEDULE.



PHOTOCELL, MOUNT ON ROOF FACING NORTH.



POWER PANEL



30A, 120V, 1PH RECEPTACLE MOUNTED AT 18 INCHES AFF.



DUPLEX RECEPTACLE 20A, 125 VOLT WALL MOUNTED AT 18 INCHES AFF. G = GROUND FAULT INTERRUPTING, T = TAMPERPROOF.



CONTROLLED DUPLEX RECEPTACLE 20A, 125 VOLT WALL MOUNTED AT 18 INCHES AFF. T = TAMPERPROOF.



DUPLEX RECEPTACLE 20A, 125 VOLT WALL MOUNTED HORIZONTALLY 2" ABOVE COUNTERTOP BACKSPASH TO THE BOTTOM OF THE RECEPTACLE COVERPLATE.



FOURPLEX RECEPTACLE 20A, 125 VOLT, WALL MOUNTED AT 18 INCHES AFF.

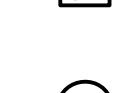

FOURPLEX RECEPTACLE. (2)20A, 125 VOLT, DUPLEX RECEPTACLES; ONE SWITCHED, ONE UN-SWITCHED, WALL MOUNTED AT 18 INCHES AFF. U = USB / 120V, 20A DUPLEX RECEPTACLE.



DUPLEX RECEPTACLE 20A, 125 VOLT MOUNTED IN FLUSH FLOOR BOX WITH CARPET FLANGE.



SPECIAL RECEPTACLE. AMPERAGE AND VOLTAGE AS SHOWN.



CARD READER. PROVIDE 4" SQUARE JUNCTION BOX AT 42" AFF AND 1"C.O. TO I.T. ROOM. WIRING AND DEVICES BY OWNERS SECURITY VENDOR.



PA SPEAKER LOCATION. PROVIDE 3/4"C-PULLSTRING TO HEADEND EQUIPMENT. SEE AV DRAWINGS FOR DAISY CHAINED DEVICES. SEE AV / IT DRAWINGS FOR RACK LOCATION. ALL WIRING AND DEVICES BY OTHERS.



MIC LOCATION. PROVIDE 3/4"C-PULLSTRING TO HEADEND EQUIPMENT. SEE AV / IT DRAWINGS FOR RACK LOCATION. ALL WIRING AND DEVICES BY OTHERS.

S

LIGHT SWITCH TOGGLE TYPE, SINGLE POLE, SUBSCRIPTS: 3 = THREE WAY, 4 = FOUR WAY, D = DIMMER CONTROL, K = KEY OPERATED, P = PILOT LIGHT, a, b, c, ETC = NUMBER OF SWITCHES AT THE LOCATION AND SPECIFIC FIXTURES CONTROLLED. MOUNT AT 42 INCHES AFF.

St

DIGITAL 0-12 HOUR TIMER SWITCH. SENSORWORX #SWX-843-12H OR EQUAL.

Sy

AUTOMATIC/MANUAL OCCUPANCY SENSOR AND SINGLE POLE TOGGLE SWITCH. SENSORWORX #SWX-123 OR EQUAL. SWITCH SHALL BE PROGRAMMED FOR MANUAL ON, AUTOMATIC OFF.

SyDL

AUTOMATIC/MANUAL OCCUPANCY SENSOR SWITCH WITH DAYLIGHT PHOTOSENSOR. SENSORWORX #SWX-133-D OR EQUAL. SWITCH SHALL BE PROGRAMMED FOR MANUAL ON, AUTOMATIC OFF.

Sm

WIRELESS NETWORKED LIGHT SWITCH. D=DIMMER, 3=THREE WAY, 4=FOUR WAY.

UO

WIRELESS INPUT/ OUTPUT POWER PACK MODULE FOR LIGHT CONTROLS.

OS

DUAL TECHNOLOGY AUTOMATIC OCCUPANCY SENSOR DEVICE WITH POWER PACK (WATT STOPPER #DT-300).

PS

DAYLIGHT PHOTOSENSOR

DS

DISCONNECT SWITCH

FS

FUSED DISCONNECT SWITCH WITH FUSES.

Sm

MOTOR RATED TOGGLE SWITCH WITH OVERLOAD HEATER(S), SIZE PER NEC AND MANUFACTURERS REQUIREMENTS.

TTB

TELEPHONE TERMINAL BOARD. 4"x8"x3/4" EXTERIOR GRADE, FIRE RESISTANT TREATED PLYWOOD

V

FLUSH MOUNTED DUAL TELEPHONE/DATA OUTLET, MOUNT AT 18" AFF UNLESS NOTED OTHERWISE ON ELECTRICAL OR TELECOM/AV DRAWINGS. PROVIDE 4" SQUARE BOX WITH 1" CONDUIT AND PULL STRING TO ACCESSIBLE CEILING SPACE OR DIRECTLY BACK TO I.T. RACK IN OPEN CEILING AREAS. WAP=WIRELESS ACCESS POINT. C=CEILING MOUNTED. WP= IN-USE WEATHERPROOF COVER.

T

TRANSFORMER. SIZE AND TYPE AS NOTED. PROVIDE GROUNDING AS REQUIRED BY NEC TABLE 250.102(C)(1).

⊥

GROUND PER NEC.

F

MANUAL FIRE ALARM PULL STATION. WALL MOUNT AT 42 INCHES AFF.

H

FIRE ALARM HORN WALL MOUNT AT 80 INCHES AFF.

F<sup>XX</sup>

FIRE ALARM HORN/ADA STROBE. WALL MOUNT AT 80 INCHES AFF. SUBSCRIPT INDICATES CANDELA LEVEL.

V<sup>XX</sup>

FIRE ALARM MINI ADA STROBE, WALL MOUNT AT 80 INCHES AFF. SUBSCRIPT INDICATES CANDELA LEVEL.

M<sup>XX</sup>

FIRE ALARM MINI HORN/ADA STROBE, WALL MOUNT AT 80 INCHES AFF. SUBSCRIPT INDICATES CANDELA LEVEL.

S<sup>XX</sup>

FIRE ALARM SPEAKER/ADA STROBE, WALL MOUNT AT 80 INCHES AFF. SUBSCRIPT INDICATES CANDELA LEVEL.

◆

DOOR CONTACT 6" IN FROM STRIKE.

S

SMOKE DETECTOR

H

HEAT DETECTOR

FS

WATER SPRINKLER SYSTEM FLOW SWITCH.

TS

WATER SPRINKLER SYSTEM TAMPER SWITCH.

XXX

AVAILABLE FAULT CURRENT

V S

TRANSIENT VOLTAGE SURGE SUPPRESSION. TPS3-X-11-15-D2, SIEMENS OR EQUAL. "X" = VOLTAGE/PHASE (VARIES), SEE POWER RISER DIAGRAM AND/OR PANEL SCHEDULES FOR VOLTAGE AND PHASE REQUIREMENTS.

(E)

EXISTING

WP

WEATHERPROOF

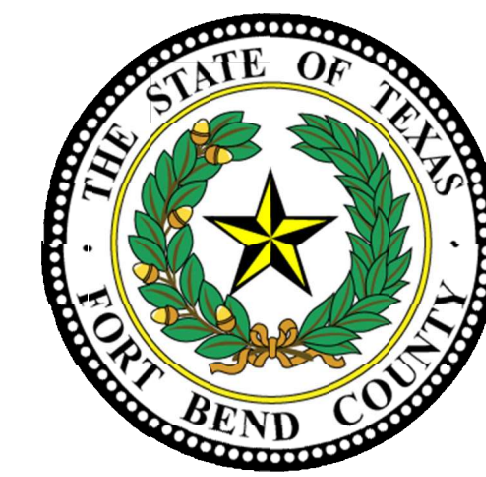

Project:  
Mustang Park Renovation &  
New Construction

4521 FM 521  
FRESNO, TX 77545

Prepared For:  
**FORT BEND COUNTY**  
5855 Sienna Springs Way,  
Missouri City, TX 77459



Contract No: 2024-002  
Design Team:



All reproduction & intellectual property rights reserved  
Key Plan

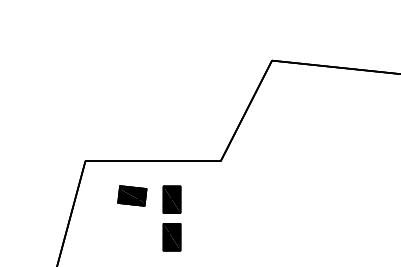

Professional Seals

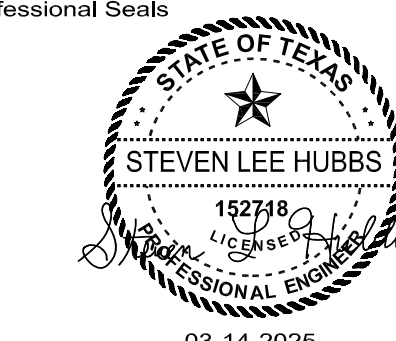

No.	Issue Description	MM-DD-YYYY
1	ISSUED FOR CONSTRUCTION	03-14-2025
1	ADDENDUM 1	08-20-2025
2	ASI #001	10-21-2025

Drawn by: JAE Reviewed by: SLH

Project No: 2024-002

Sheet Title:

**ELECTRICAL SITE LIGHTING PLAN**

Orig. drawing is ARCH D. Do not scale contents of this drawing.  
Sheet Number

**E101**

**GENERAL NOTES:**

- ELECTRICAL REQUIREMENTS ARE NOT LIMITED TO ELECTRICAL DRAWINGS AND SPECIFICATIONS. THERE IS ADDITIONAL ELECTRICAL WORK REQUIRED TO BE INCLUDED IN THE BID, INDICATED ON ARCHITECTURAL, LANDSCAPE, CIVIL, MECHANICAL, DATA, AND AUDIO VISUAL DRAWINGS. ADDITIONAL ELECTRICAL WORK REQUIRED IN THE BID IS ALSO LOCATED IN THE SPECIFICATIONS. CONTRACTOR SHALL REVIEW ALL ARCHITECTURAL, CIVIL, LANDSCAPE, MECHANICAL, DATA, AND AUDIO VISUAL SPECIFICATIONS FOR ADDITIONAL ELECTRICAL INFORMATION AND INCLUDE COSTS FOR THIS WORK IN THE BID.
- ALL CONDUIT IS INTENDED TO BE CONCEALED. CONTRACTOR SHALL PROVIDE TO ARCHITECT/OWNER SHOP DRAWINGS INDICATING ROUTING OF ANY INTENDED EXPOSED CONDUIT PRIOR TO ROUGH-IN FOR ARCHITECT/OWNERS APPROVAL. CONTRACTOR SHALL NOT START ROUGH-IN FOR CONDUIT UNTIL WRITTEN APPROVAL IS RECEIVED.
- CONTRACTOR SHALL REFER TO ARCHITECTURAL DRAWINGS FOR THE FIRE WALL SEPARATIONS. CONTRACTOR SHALL PROVIDE CAULKING, SEAL-OFFS, RATED PENETRATION BLOCK-OUTS, ETC. AS REQUIRED BY CODE TO RETAIN FIRE WALL SEPARATION RATINGS.
- CONTRACTOR SHALL INCLUDE IN THE BID ALL COSTS TO HAVE AN AUTHORITY HAVING JURISDICTION APPROVED FIRM TO EVALUATE THE INSTALLATION, SAFETY, AND COMPLIANCE WITH CODE AS REQUIRED. FOR ANY EQUIPMENT SPECIFIED OR FURNISHED THAT IS NOT UL LABELED.
- THE CONTRACTOR SHALL BE FULLY RESPONSIBLE FOR THE LOCATION AND PROTECTION OF ALL EXISTING UTILITIES. THE CONTRACTOR SHALL VERIFY ALL UTILITY LOCATIONS PRIOR TO CONSTRUCTION BY CALLING THE UNDERGROUND LOCATE LINE AT A MINIMUM OF 48 HOURS PRIOR TO ANY EXCAVATION. THE CONTRACTOR WILL ALSO BE RESPONSIBLE FOR MAINTAINING ALL LOCATE MARKS ONCE THE UTILITIES HAVE BEEN LOCATED.
- ALL WALL PENETRATIONS SHALL BE NEATLY CORE-DRILLED, CAULKED AND SEALED TO MAINTAIN FIRE, AND WATERPROOF RATING. PATCH, REPAIR, AND PAINT TO MATCH EXISTING.
- CONTRACTOR SHALL PROVIDE TRENCHED 1" C-FIRE ALARM CONDUCTORS AND CONNECT THE POST INDICATOR VALVE TO THE FIRE ALARM SYSTEM FOR MONITORING. SEE CIVIL AND MECHANICAL DRAWINGS FOR LOCATIONS.

**ELECTRICAL NOTES:**

- CONTRACTOR SHALL RELOCATE EXISTING LIGHT POLE, POLE BASE, PROVIDE CONDUIT / CONDUCTORS AND RECONNECT TO EXISTING CIRCUITRY AND CONTROLS.
- LIGHTING CONTROL MODULE INSIDE COMMUNITY BUILDING.

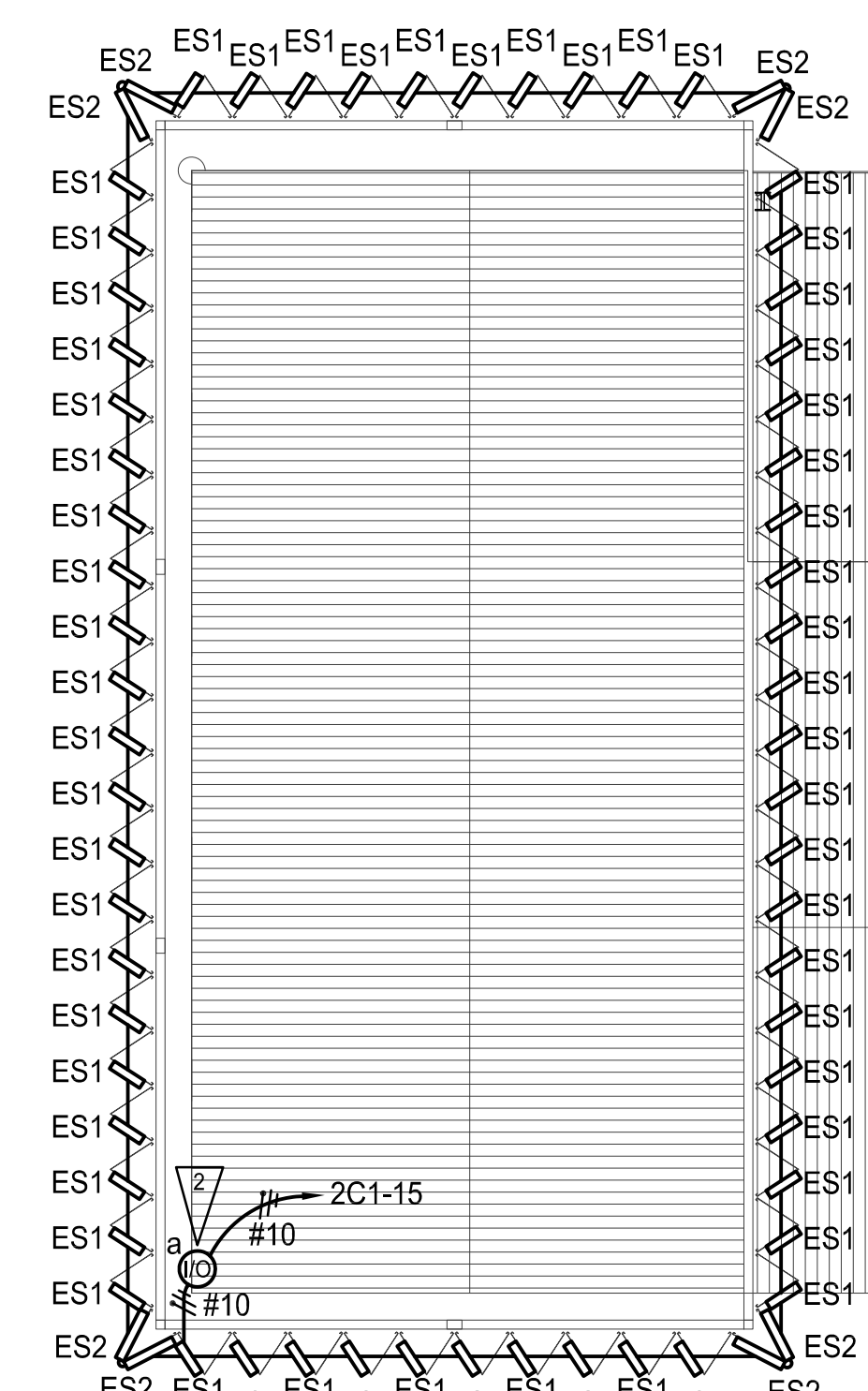
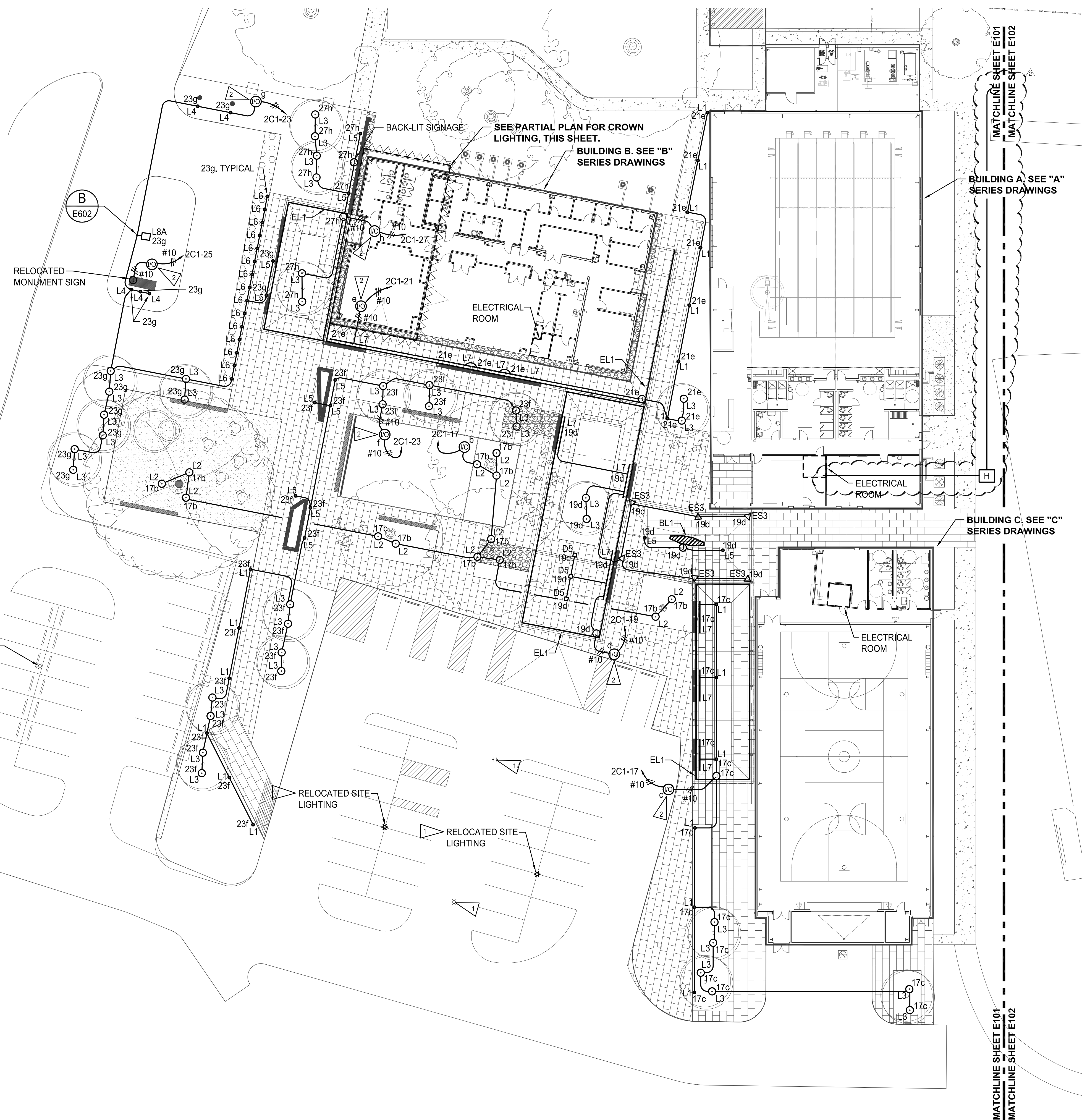

**ELECTRICAL SITE LIGHTING PLAN**  
SCALE: 1"=20'-0"

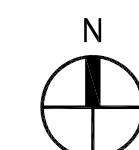

**CROWN LIGHTING PLAN**  
SCALE: 1"=10'-0"





Project:  
**Mustang Park Renovation & New Construction**

4521 FM 521  
FRESNO, TX 77545

Prepared For:  
**FORT BEND COUNTY**  
5855 Sienna Springs Way,  
Missouri City, TX 77459



Contract No: 2024-002

Design Team:



All reproduction & intellectual property rights reserved  
Key Plan

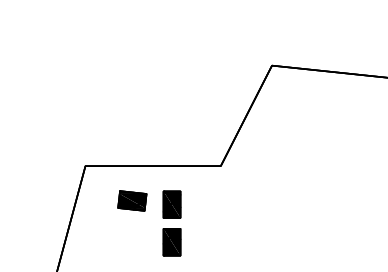

Professional Seals

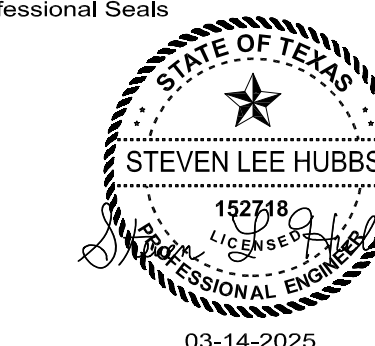

No.	Issue Description	MM-DD-YYYY
	ISSUED FOR CONSTRUCTION	03-14-2025
1	ADDENDUM 1	08-20-2025
2	ASI #001	10-21-2025

Drawn by: JAE Reviewed by: SLH

Project No: 2024-002

Sheet Title:

**ELECTRICAL SITE PLAN**

Orig. drawing is ARCH D.Do not scale contents of this drawing.  
Sheet Number

**E102**

**GENERAL NOTES:**

1. ELECTRICAL REQUIREMENTS ARE NOT LIMITED TO ELECTRICAL DRAWINGS AND SPECIFICATIONS. THERE IS ADDITIONAL ELECTRICAL WORK REQUIRED TO BE INCLUDED IN THE BID. INDICATED ON ARCHITECTURAL, LANDSCAPE, CIVIL, MECHANICAL, DATA, AND AUDIO VISUAL DRAWINGS. ADDITIONAL ELECTRICAL WORK REQUIRED IN THE BID IS ALSO LOCATED IN THE SPECIFICATIONS. CONTRACTOR SHALL REVIEW ALL ARCHITECTURAL, CIVIL, LANDSCAPE, MECHANICAL, DATA, AND AUDIO VISUAL SPECIFICATIONS FOR ADDITIONAL ELECTRICAL INFORMATION AND INCLUDE COSTS FOR THIS WORK IN THE BID.

**ELECTRICAL NOTES:**

1. CONTRACTOR SHALL PROVIDE NEMA 3R, 60A, MAIN BREAKER PANELBOARD WITH 12 CIRCUITS AND PORTABLE GENERATOR RECEPTACLE MOUNTED TO STRUT STRUCTURE. PROVIDE 3/4"C-#10 CU CONDUCTORS AND CONNECT DUPLEX (1.5HP) PUMPS VIA PUMP CONTROL PANEL. PROVIDE 120V, 20A, GFCI, WP DUPLEX RECEPTACLE MOUNTED ADJACENT TO ELECTRICAL PANEL, PROVIDE 3/4"C-#12 CU CONDUCTORS AND CONNECT TO PANEL P.

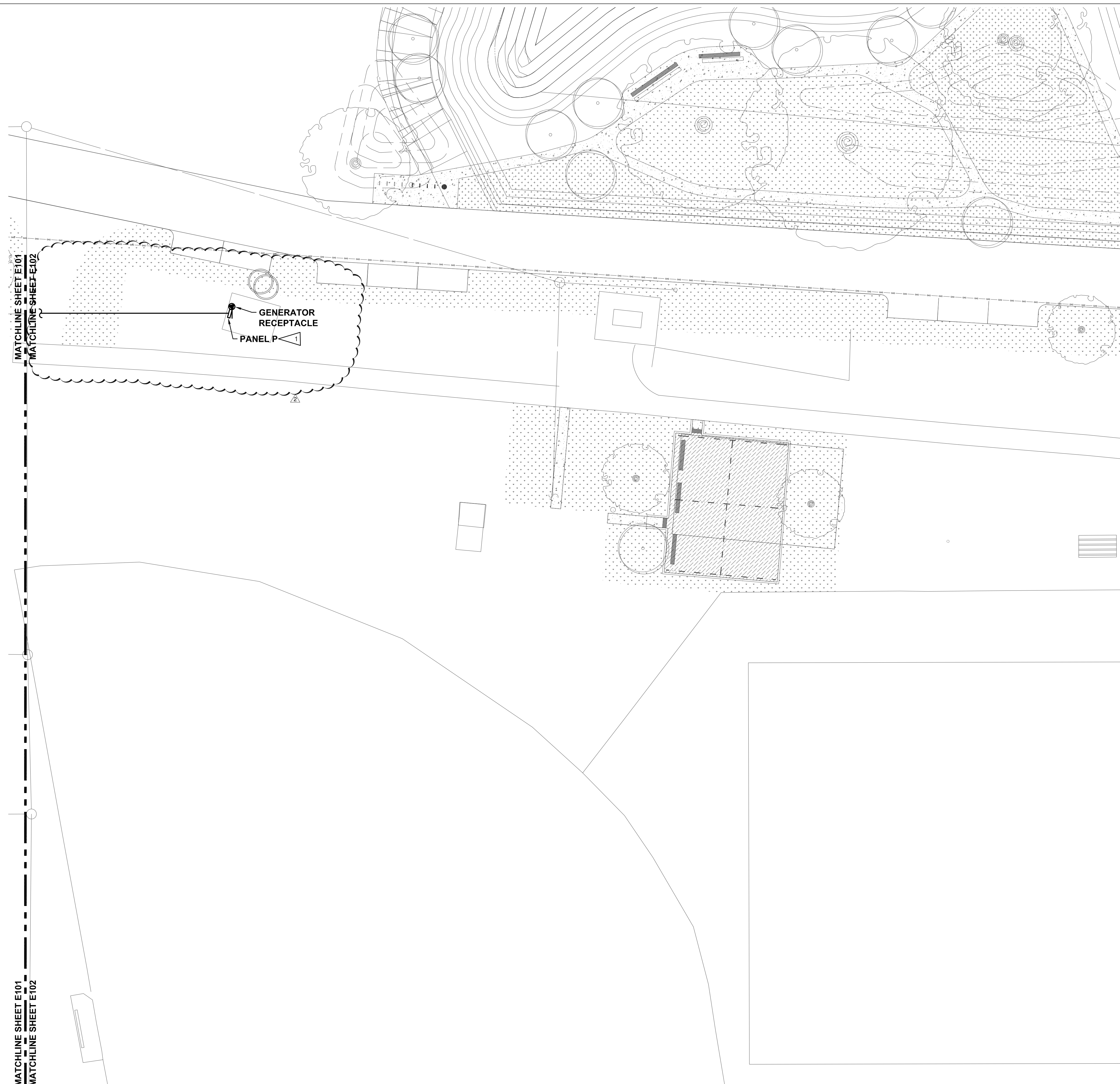

GENERATOR RECEPTACLE  
PANEL P

**ELECTRICAL SITE PLAN**

SCALE: 1"=20'-0"

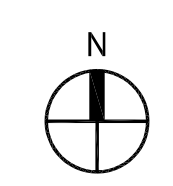

8/16/2024 11:09:43 AM



Project:  
**Mustang Park Renovation & New Construction**

4521 FM 521  
FRESNO, TX 77545

Prepared For:  
**FORT BEND COUNTY**  
5855 Sienna Springs Way,  
Missouri City, TX 77459



Contract No: 2024-002  
Design Team:



All reproduction & intellectual property rights reserved  
Key Plan

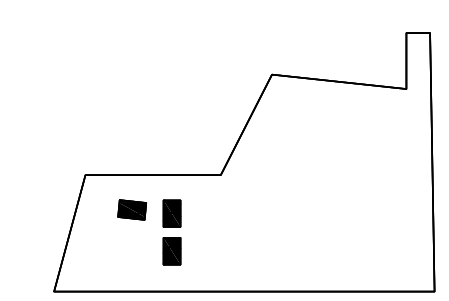

Professional Seals

No.	Issue Description	MM-DD-YYYY
1	ISSUED FOR CONSTRUCTION	03-14-2025
1	ADDENDUM 1	08-20-2025
2	ASI #001	10-21-2025

Drawn by: JAE Reviewed by: SLH  
Project No: 2024-002

Sheet Title:  
**NATATORIUM POWER RISER DIAGRAM**

Orig. drawing is ARCH D. Do not scale contents of this drawing.  
Sheet Number

**A-E501**

SURFACE MOUNTING 22,000 AIC														
PANEL SCHEDULE		480/277 VOLTS 3PHASE 4WIRE 800 AMPS WITH 800 MAIN BREAKER						120/208 VOLTS 3PHASE 4WIRE 200 AMPS WITH 200 MAIN BREAKER						
NO.	LOCATION:	ELECTRICAL ROOM		SERVING:		NATATORIUM		ELECTRICAL ROOM		SERVING:		NATATORIUM		
CKT NO.	LOAD DESCRIPTION	KVA	TRIP AMPS	TRIP AMPS	KVA	LOAD DESCRIPTION	CKT NO.	LOAD DESCRIPTION	KVA	TRIP AMPS	TRIP AMPS	KVA	LOAD DESCRIPTION	CKT NO.
1	RECEPTACLES	.90	20	20	.60	H-1A	2					.60	TV'S (QTY 2)	2
3		.90	20	20	1.08	H-1A	4					1.00	TREADMILL	4
5		.36	20	20	.50	EV-1A	6					1.00	TREADMILL	6
7		.36	20	20	2.40	CP-1A	8					1.00	TREADMILL	8
9		.18	20	20	.12	CP-1A	10					.60	BIKE	10
11		.18	20	20	2.40	C-1A	12					.60	BIKE	12
13		.18	20	20	.12	C-1A	14					.60	BIKE	14
15		.18	20	20	2.88	AF-1A	16					.60	TV'S (QTY 2)	16
17		.18	20	20	.12	AF-1A	18					.75	CEILING FAN	18
19		.18	20	20	2.40	AP-1A	20					.75	CEILING FAN	20
21		.18	20	20	.12	AP-1A	22					.18	SPARE	22
23		.18	20	20	1.50	HAND DRYER	24					.18	SPARE	24
25		.54	20	20			26					.30	H.C. DOOR	26
27	RECEPTACLES	.54	20	20	.18	I.T. RECEPTACLE	28					.18	I.T. RECEPTACLE	28
29	SPARE		20	20	1.50	I.T. RECEPTACLE	30					1.50	I.T. RECEPTACLE	30
31	SPARE		20	20	.72	RECEPTACLES	32					.72	RECEPTACLES	32
33	HAND DRYER	1.50	20	20	.10	FIRE ALARM PANEL	36					.10	FIRE ALARM PANEL	36
37			20	20		TVSS	38						TVSS	38
39	HAND DRYER	1.50	20	20			40							40
41			20	20			42							42
43	COMPRESSOR	3.00	20	20			44							44
45			20	20			46							46
47	DRINKING FOUNTAIN	.18	20	20			48							48
49	WH-1A	1.50	20	20			50							50
51	SPARE		20	20			52							52
53			20	20			54							54
55			20	20			56							56
57			20	20			58							58
59	SPARE		20	20			60							60

REMARKS: PROVIDE FEED THRU LUGS. CONNECTED LOAD: 30.0 KVA 83 AMPS  
DEMAND LOAD: 31.5 KVA 87 AMPS

\* PROVIDE HANDLE LOCK.  
\*\* PROVIDE GFI CIRCUIT BREAKER  
PROVIDE HANDLE TIES FOR ALL MULTI-CIRCUIT HOMERUNS SHARING A NEUTRAL PER THE NATIONAL ELECTRIC CODE ARTICLE 210.4 MULTIWIRE BRANCH CIRCUITS, PART (B) DISCONNECTING MEANS. DRAWINGS ARE DIAGRAMMATIC. WHERE THE CONTRACTOR MODIFIES THE CIRCUITING, THE CONTRACTOR SHALL PROVIDE AN INDIVIDUAL NEUTRAL PER CIRCUIT, MULTI-POLE CIRCUIT BREAKERS, OR CIRCUIT BREAKER HANDLE TIE TO MEET THE NEC ARTICLE. ALL COSTS ASSOCIATED WITH MODIFICATIONS SHALL BE INCLUDED IN THE CONTRACTOR'S BID.

PANEL 2N2 LOAD CALCULATIONS				
SERVICE	KVA LOAD	FACTOR	NEC REF.	DEMAND LOAD
LIGHTING	-	X	1.25	220.19(A)(1) = -
RECEPTS TO 10KW	6.12	X	1.00	220.44 = 6.12
RECEPTS OVER 10KW	-	X	0.50	220.44 = -
MOTORS (LARGEST)	5.76	X	1.25	430.24 = 7.20
MOTORS	5.76	X	1.00	430.24 = 5.76
KITCHEN EQUIP.	-	X	1.00	220.56 = -
WELDERS	-	X	1.00	630.11(B) = -
AIR CONDITIONING	-	X	1.00	220.50 = -
ELECTRIC HEAT	-	X	1.00	220.51 = -
MISCELLANEOUS	12.40	X	1.00	12.40 = 12.40

TOTAL CONNECTED 30.0 KVA (83 AMPS) TOTAL DEMAND 31.5 KVA (87 AMPS)

SURFACE MOUNTING 22,000 AIC														
PANEL SCHEDULE		480/277 VOLTS 3PHASE 4WIRE 800 AMPS WITH 800 MAIN BREAKER						120/208 VOLTS 3PHASE 4WIRE 200 AMPS WITH 200 MAIN BREAKER						
NO.	LOCATION:	ELECTRICAL ROOM		SERVING:		NATATORIUM		ELECTRICAL ROOM		SERVING:		NATATORIUM		
CKT NO.	LOAD DESCRIPTION	KVA	TRIP AMPS	TRIP AMPS	KVA	LOAD DESCRIPTION	CKT NO.	LOAD DESCRIPTION	KVA	TRIP AMPS	TRIP AMPS	KVA	LOAD DESCRIPTION	CKT NO.
1	CP-1A	.50	20	20	.96	H-1A	2					.60	H-1A	2
3	CP-2A, TP-1 (QTY 5)	.50	20	20	1.08	H-1A	4					1.00	H-1A	4
5	EF-1A	.43	20	20	.50	EV-1A	6					.50	EV-1A	6
7	LIGHTING	1.46	20	20	2.40	CP-1A	8					2.40	CP-1A	8
9		1.28	20	20	.12	CP-1A	10					.12	CP-1A	10
11		1.14	20	20	2.40	C-1A	12					2.40	C-1A	12
13	LIGHTING	.77	20	20	.12	C-1A	14					.12	C-1A	14
15	SPARE		20	20	2.88	AF-1A	16					2.88	AF-1A	16
17	CU-1A	8.74	70	20	.12	AF-1A	18					.12	AF-1A	18
19			20	20	2.40	AP-1A	20					2.40	AP-1A	20
21	CU-2A	8.74	70	20	.12	AP-1A	22					.12	AP-1A	22
23			20	20	1.50	HAND DRYER	24					1.50	HAND DRYER	24
25	ERV-1A	1.58	30	20			26							26
27			20	20			28							28
29	FC-1A,2A,3A	4.31	30	20	1.50	HAND DRYER	30					1.50	HAND DRYER	30
31			20	20			32							32
33	CU-3A	8.74	70	20			34							34
35			20	20	2.50	BP-1A	36					2.50	BP-1A	36
37	TVSS		30	20			38							38
39			20	20	2.50	UV-1A	40					2.50	UV-1A	40
41			30	20			42							42

REMARKS: PROVIDE GFCI CIRCUIT BREAKER. CONNECTED LOAD: 60.8 KVA 169 AMPS  
DEMAND LOAD: 64.1 KVA 178 AMPS

\* PROVIDE GFCI CIRCUIT BREAKER.  
PROVIDE HANDLE TIES FOR ALL MULTI-CIRCUIT HOMERUNS SHARING A NEUTRAL PER THE NATIONAL ELECTRIC CODE ARTICLE 210.4 MULTIWIRE BRANCH CIRCUITS, PART (B) DISCONNECTING MEANS. DRAWINGS ARE DIAGRAMMATIC. WHERE THE CONTRACTOR MODIFIES THE CIRCUITING, THE CONTRACTOR SHALL PROVIDE AN INDIVIDUAL NEUTRAL PER CIRCUIT, MULTI-POLE CIRCUIT BREAKERS, OR CIRCUIT BREAKER HANDLE TIE TO MEET THE NEC ARTICLE. ALL COSTS ASSOCIATED WITH MODIFICATIONS SHALL BE INCLUDED IN THE CONTRACTOR'S BID.

PANEL 2N1 LOAD CALCULATIONS				
SERVICE	KVA LOAD	FACTOR	NEC REF.	DEMAND LOAD
LIGHTING	4.65	X	1.25	220.19(A)(1) = 5.81
RECEPTS TO 10KW	-	X	1.00	220.44 = -
RECEPTS OVER 10KW	-	X	0.50	220.44 = -
MOTORS (LARGEST)	8.74	X	1.25	430.24 = 10.93
MOTORS	42.90	X	1.00	430.24 = 42.90
KITCHEN EQUIP.	-	X	1.00	220.56 = -
WELDERS	-	X	1.00	630.11(B) = -
AIR CONDITIONING	-	X	1.00	220.50 = -
ELECTRIC HEAT	-	X	1.00	220.51 = -
MISCELLANEOUS	4.50	X	1.00	4.50 = 4.50

TOTAL CONNECTED 60.8 KVA (169 AMPS) TOTAL DEMAND 64.1 KVA (178 AMPS)

SURFACE MOUNTING 35,000 AIC														
PANEL SCHEDULE		480/277 VOLTS 3PHASE 4WIRE 800 AMPS WITH 800 MAIN BREAKER						120/208 VOLTS 3PHASE 4WIRE 200 AMPS WITH 200 MAIN BREAKER						
NO.	LOCATION:	ELECTRICAL ROOM		SERVING:		NATATORIUM		ELECTRICAL ROOM		SERVING:		NATATORIUM		
CKT NO.	LOAD DESCRIPTION	KVA	TRIP AMPS	TRIP AMPS	KVA	LOAD DESCRIPTION	CKT NO.	LOAD DESCRIPTION	KVA	TRIP AMPS	TRIP AMPS	KVA	LOAD DESCRIPTION	CKT NO.
1	AHU-1A.2	12.70	30	20		SPARE	2							2
3			30	20		SPARE	4							4
5			30	20		SPARE	6							6
7	SPARE		60	30		SPARE	8							8
9			30	30			10							10
11			30	30			12							12
13	AHU-1A	138.61	200	30	16.60	ER-1A	14							14
15			200	30			16							16
17			30	30			18							18
19	EW-1A	36.00	60	30	12.70	CU-4A	20							20
21			60	30			22							22
23			30	30			24							24
25	EW-2A	36.00	60	30	11.62	V-1A/P-1A	26							26
27			60	30			28							28
29			30	30			30							30
31	EW-3A	36.00	60	125	18.52	PANEL 2N2 (VIA XFMR)	32							32
33			60	125			34							34
35			30	125			36							36
37	TVSS		30	125	60.80	PANEL 2N1 (VIA XFMR)	38							38
39			30	125			40							40
41			30	125			42							42

REMARKS: SERVICE ENTRANCE RATED. CONNECTED LOAD: 366.8 KVA 442 AMPS  
DEMAND LOAD: 402.7 KVA 485 AMPS

\* PROVIDE GFCI CIRCUIT BREAKER.  
PROVIDE HANDLE TIES FOR ALL MULTI-CIRCUIT HOMERUNS SHARING A NEUTRAL PER THE NATIONAL ELECTRIC CODE ARTICLE 210.4 MULTIWIRE BRANCH CIRCUITS, PART (B) DISCONNECTING MEANS. DRAWINGS ARE DIAGRAMMATIC. WHERE THE CONTRACTOR MODIFIES THE CIRCUITING, THE CONTRACTOR SHALL PROVIDE AN INDIVIDUAL NEUTRAL PER CIRCUIT, MULTI-POLE CIRCUIT BREAKERS, OR CIRCUIT BREAKER HANDLE TIE TO MEET THE NEC ARTICLE. ALL COSTS ASSOCIATED WITH MODIFICATIONS SHALL BE INCLUDED IN THE CONTRACTOR'S BID.

PANEL 4N LOAD CALCULATIONS				
SERVICE	KVA LOAD	FACTOR	NEC REF.	DEMAND LOAD
LIGHTING	4.65	X	1.25	220.19(A)(1) = 5.81
RECEPTS TO 10KW	6.12	X	1.00	220.44 = 6.12
RECEPTS OVER 10KW	-	X	0.50	220.44 = -
MOTORS (LARGEST)	138.61	X	1.25	430.24 = 173.26
MOTORS	92.56	X	1.00	430.24 = 92.56
KITCHEN EQUIP.	-	X	1.00	220.56 = -
WELDERS	-	X	1.00	630.11(B) = -
AIR CONDITIONING	-	X	1.00	220.50 = -
ELECTRIC HEAT	108.00	X	1.00	220.51 = 108.00
MISCELLANEOUS	16.90	X	1.00	16.90 = 16.90

TOTAL CONNECTED 366.8 KVA (442 AMPS) TOTAL DEMAND 402.7 KVA (485 AMPS)

SURFACE MOUNTING 10,000 AIC														
PANEL SCHEDULE		120/208 VOLTS 3PH 4WIRE 60 AMPS WITH 60 MAIN BREAKER						120/208 VOLTS 3PH 4WIRE 60 AMPS WITH 60 MAIN BREAKER						
NO.	LOCATION:	SITE		SERVING:		STORM PUMPS		ELECTRICAL ROOM		SERVING:		STORM PUMPS		
CKT NO.	LOAD DESCRIPTION	KVA	TRIP AMPS	TRIP AMPS	KVA	LOAD DESCRIPTION	CKT NO.	LOAD DESCRIPTION	KVA	TRIP AMPS	TRIP AMPS	KVA	LOAD DESCRIPTION	CKT NO.
1	PUMP 1	5.76	30	30	5.76	PUMP 2	2							2
3			30	30			4							4
5			30	30			6							6
7	SPACE		20	20	.18	RECEPTACLE	8							8
9	SPACE		20	20		SPACE	10							



# Phoenix Construction Services

PO Box 2788 • Alvin, TX 77512-2788

Ph: (281) 388 - 2211 • Fax: (281) 585 - 6021

November 25, 2025

PHX RCO#                    26-2001    1

Ted Tou  
Patriot Contracting, LLC  
300 Shepard Drive, Suite A  
Houston, TX 77007-7

Phone  
Fax

**Project:**

Fort Bend County Mustang Park  
4521 FM 521  
Fresno, TX 77459

**RE:**

1

Furnish and install new LVL ceiling joists and 3/4" FRT plywood over kitchen and corridor

***THIS WORK WILL BE COMPLETED FOR:***

**\$15,855**

Please issue a change order for the work described above, your expedience is greatly appreciated. If there are any questions.

Thank You,

Mark Hamilton  
Estimator



**Patriot Contracting LLC**  
 300 Shepherd Drive, Suite A  
 Houston, Texas 77007  
 P: 7138803444

**Project: Fort Bend County Mustang Park**  
 4521 FM 521  
 Fresno, Texas 77545

## RFI #22: Kitchen New Ceiling

<b>Revision</b>	0	<b>Status</b>	Open
<b>To</b>	Ted Tou (Patriot Contracting LLC)	<b>From</b>	Ted Tou (Patriot Contracting LLC) 300 Shepherd Drive, Suite A Houston, Texas 77007
<b>Date Initiated</b>	Dec 9, 2025	<b>Due Date</b>	Dec 12, 2025
<b>Location</b>		<b>Project Stage</b>	Course of Construction
<b>Cost Impact</b>	\$5,000.00	<b>Schedule Impact</b>	Yes (Unknown)
<b>Spec Section</b>		<b>Cost Code</b>	
<b>Drawing Number</b>		<b>Reference</b>	
<b>Linked Drawings</b>			
<b>Received From</b>	Mark Micho (Patriot Contracting LLC)		
<b>Copies To</b>			
<b>Emailed to Architect</b>	Yes	<b>Date Sent to Architect</b>	12/09/25

### Activity

#### Question

**Question from Ted Tou Patriot Contracting LLC on Tuesday, Dec 9, 2025 at 01:05 PM CST**

Demo plans calls for existing kitchen ceiling in the Community Center to remain. Per RFI #6 it has now been demo'd.

The architectural floor plans call for the very kitchen ceiling to be water resistant plaster aka Ceiling #5 (same as ceiling in Natatorium). We do not feel that this is necessary for this location.

RFI #21 suggests for us to demo and reinstall the support wooden joist for the kitchen ceiling. It would make sense to just install sufficient supports for new gypsum ceiling INSTEAD of water resistant plaster.

**RECOMMENDATION:** Approve for new gypsum drywall ceilings for cost savings to the owner. This will also prevent the stucco from cracking in the future when someone is above the ceiling

*Awaiting an Official Response*

**Response:**  
**Recommendation accepted.**  
**Signed: N Stearley**  
**Date: 12/10/2025**

## Ted Tou

---

**From:** Gregory Lake <gregory.lake@hinesad.com>  
**Sent:** Monday, November 24, 2025 3:52 PM  
**To:** Ted Tou  
**Cc:** Mark Micho; Elton Allemang; Nora Villarreal; Antonio Perez  
**Subject:** Re: Mustang Park - RFI 021 RESPONSE

Agree. Unforeseen conditions.

Thanks.

G

### Gregory L. Lake, AIA

PRINCIPAL

**HINES ARCHITECTURE+DESIGN**  
8 GREENWAY PLAZA, SUITE 1525 | HOUSTON, TX 77046 USA  
PH 713 909 0983 C 832 405 4412  
[www.hinesad.com](http://www.hinesad.com)

**CONFIDENTIALITY CAUTION:** This message contains information from the company that may be proprietary, confidential and/or privileged. The information is intended only for the use of the individual or entity to whom it is addressed. If you are not the intended recipient, please notify us immediately by return e-mail, delete this message and you should not disseminate, distribute or copy any information contained herein.

On Mon, Nov 24, 2025 at 2:58 PM Ted Tou <[Ted@patriotllc.us](mailto:Ted@patriotllc.us)> wrote:

Gregory, I will get the pricing for this and revert back. Thanks

---

**From:** Gregory Lake <[gregory.lake@hinesad.com](mailto:gregory.lake@hinesad.com)>  
**Sent:** Monday, November 24, 2025 6:01 AM  
**To:** Ted Tou <[Ted@patriotllc.us](mailto:Ted@patriotllc.us)>; Mark Micho <[mmicho@patriotllc.us](mailto:mmicho@patriotllc.us)>; Elton Allemang <[era@patriotllc.us](mailto:era@patriotllc.us)>  
**Cc:** Nora Villarreal <[nora@patriotllc.us](mailto:nora@patriotllc.us)>; Antonio Perez <[antonio.perez@hinesad.com](mailto:antonio.perez@hinesad.com)>  
**Subject:** Mustang Park - RFI 021 RESPONSE

For your use.

G

Gregory L. Lake, AIA

PRINCIPAL

**HINES ARCHITECTURE+DESIGN**

8 GREENWAY PLAZA, SUITE 1525 | HOUSTON, TX 77046 USA

PH 713 909 0983 C 832 405 4412

[www.hinesad.com](http://www.hinesad.com)

**CONFIDENTIALITY CAUTION:** This message contains information from the company that may be proprietary, confidential and/or privileged. The information is intended only for the use of the individual or entity to whom it is addressed. If you are not the intended recipient, please notify us immediately by return e-mail, delete this message and you should not disseminate, distribute or copy any information contained herein.



**Boise Cascade®**  
ENGINEERED WOOD PRODUCTS

Specifier Guide | East  
BCI® Joists and Versa-Lam® LVL



# BCI JOIST AND VERSA-LAM LVL SPECIFIER GUIDE

BCI Joists 4500s, 5000s, 6000s, 6500s, 60s, 90s  
Versa-Lam LVL 3100

[bc.com/ewp](http://bc.com/ewp)

Reorder #MTP-E7000

# Boise Cascade BCI Joist Benefits

The use of I-joists for floor and roof framing has become a construction industry standard, largely because they offer reliable strength, consistency, and engineered performance that can provide a better value than dimension lumber. But that's just the start of the benefits you get with Boise Cascade BCI® joists

## More Strength

Thanks to their unique I-joist construction, BCI® joists are 20 percent stronger than comparably sized dimension lumber. That means you can use fewer joists to achieve the floor or roof capacity you need.

## Easier Handling

While offering more strength, BCI® joists are also lightweight and easy to handle and move around the jobsite. This helps reduce labor hours—and costs.

## Longer Lengths

I-joists can be used to create long spans with less blocking for a faster installation. That is something that dimension lumber simply can't match.

## Faster Installation

BCI® joists can be quickly trimmed in the field and their top and bottom flanges offer a wider nailing surface for speedy installation.

## Always Consistent

BCI® joists are engineered and manufactured for reliability. You'll receive the same durable, consistently performing, and professionally inspected product time after time.

## Sustainably Made

The raw materials used in the manufacture of BCI® joists are sourced from sustainable and responsibly managed forests. Boise Cascade strives to maximize the use and minimize the waste of each log procured. Bark and material residuals are used for carbon-neutral biomass fuel to generate over 70% of the energy needed to manufacture our products, reducing our emissions and reliance on fossil fuels.

## TABLE OF CONTENTS

Boise Cascade Chain-Of-Custody Certifications	2
Product Storage and Handling	2
<b>BCI JOISTS</b>	<b>3</b>
Product Profiles and Architectural Specifications	3
Residential Floor Span Tables	4
One-Hour Fire Resistance Assembly	4
Floor Framing Details	5-6
Hole Location: Sizing and Rectangular Holes	7
Cantilevers: Bearing and Non-Bearing	8-9
Web Stiffener Requirements	9
Floor Load Tables	10-12
Roof Framing Details	13-14
Roof Span Tables	15-18
Uniform Roof Load Tables	19-23
BCI Joist Design Properties	24
Closest Allowable Nail Spacing	24
Rim Board Details and Properties	25
<b>Versa-Lam LVL Beams</b>	<b>26</b>
Product Profiles and Architectural Specifications	26
Versa-Lam LVL Allowable Holes	26
Details and Multiple Member Connections	27
Floor Load Table	28
Roof Load Tables	29-30
Allowable Nailing	31
Design and Allowable Stress Values	31
Versa-Lam LVL Columns	32
Framing Connectors	34-35

## Boise Cascade Chain-Of-Custody Certifications

Boise Cascade Engineered Wood Products (EWP) has a proven track record of providing quality wood products and a nationwide building materials distribution network for our customers, helping them to enhance their own businesses.

Boise Cascade engineered wood products build better homes with stronger, stiffer floors using only wood purchased in compliance with a number of green building programs.

Take a moment to view our sustainability certification at [bc.com/certification-wp/](http://bc.com/certification-wp/) or go to [bc.com/sustainability](http://bc.com/sustainability) for more information.

Boise Cascade engineered wood products throughout North America can be ordered FSC® Chain-of-Custody (COC) certified, enabling homebuilders to achieve LEED® points residential and commercial green building programs including LEED for Homes and LEED for New Construction.

Boise Cascade engineered wood products are available as PEFC® Chain-of-Custody certified, SFI® Chain-of-Custody certified and SFI® Fiber-Sourcing certified, as well as NAHB Research Center Green Approved, enabling homebuilders to also obtain green building points through the Green Building Standards.

## Code Evaluation Report: ICC-ES®/APA® ESR-1336 (IBC®, IRC®)

Protect product from rain and sun.

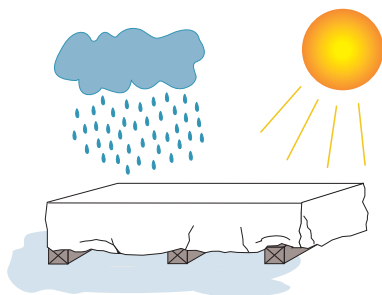

Keep product level and off the ground.

## PRODUCT STORAGE AND HANDLING

- ▶ BCI® and AJS® joists and Versa-Lam® LVL
  - must be stored, installed and used in accordance with the Boise Cascade EWP Installation Guide, building codes and, to the extent not inconsistent with the Boise Cascade EWP Installation Guide, usual and customary building practices and standards.
  - must be wrapped, covered, and stored off of the ground on stickers at all times prior to installation.
  - are intended only for applications that ensure no exposure to weather or the elements and an environment that is free from moisture from any source, or any pest, organism or substance which degrades or damages wood or glue bonds.
- ▶ Unload products carefully and support to reduce excessive bowing. Use forklifts and cranes carefully to avoid damaging product
- ▶ Do not use a visibly damaged product. Contact your local Boise Cascade representative for assistance.
- ▶ Failure to correctly store, use, or install BCI® and AJS® joists or Versa-Lam® LVL in accordance with the Boise Cascade EWP Installation Guide will void the limited warranty.

# BCI JOISTS



## Product Profiles

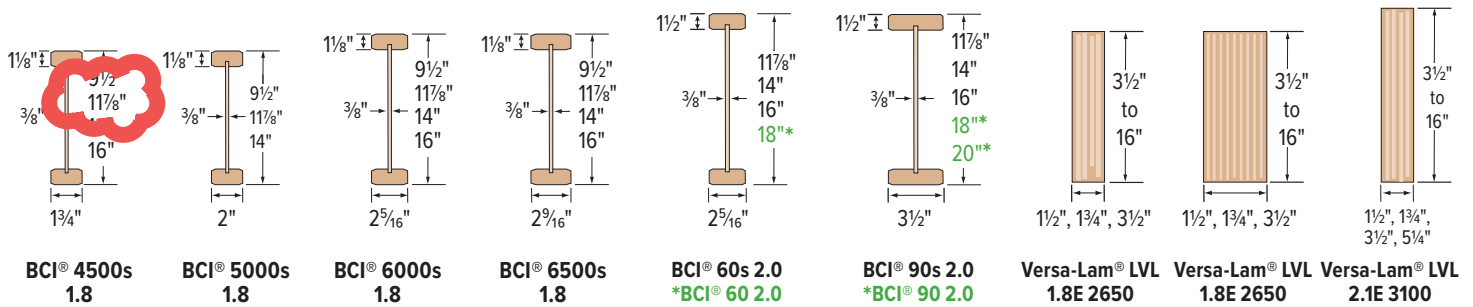

\* Deep depth BCI® 60 and 90 joists are special order.

Some products may not be available in all markets; Contact your Boise Cascade EWP representative for availability.

BCI® joists and Versa-Lam® LVL products shall be installed in dry-use applications only, per their respective ICC-ES/APA ESR evaluation reports.

## Architectural Specifications

**Scope** — This work includes the complete furnishing and installation of all BCI® joists as shown on the drawings, herein specified and necessary to complete the work.

**Materials** — BCI® joists shall be manufactured by Boise Cascade Engineered Wood Products with oriented strand board webs, Versa-Lam® laminated veneer lumber flanges, and waterproof, structural adhesives.

Joist webs shall be rated Structural I Exposure 1 by an agency listed by a model code evaluation service. Strands on the face layers of the web panels shall be oriented vertically in the joist. The web panels shall be glued together to form a continuous web member. The web panels shall be machined to fit into a groove in the center of the wide face of the flange members to form a pressed glue joint at that junction.

**Design** — The BCI® joists shall be sized and detailed to fit the dimensions and loads indicated on the plans. All designs shall be in accordance with allowable values and section properties developed in accordance with ASTM D5055, and listed in the governing code evaluation service's report.

**Drawing** — Additional drawings showing layout and detail necessary for determining fit and placement in the building are (are not) to be provided by the supplier.

**Fabrication** — The BCI® joists and section properties shall be manufactured in a plant evaluated for fabrication by the governing code evaluation service and under the supervision of a third-party inspection agency listed by the corresponding evaluation service.

**Storage and Installation** — The BCI® joists, if stored prior to erection, shall be stored in a vertical and level position and protected from the weather. They shall be handled with care so they are not damaged.

The BCI® joists are to be installed in accordance with the plans and the Boise Cascade Engineered Wood Products Installation Guide. Temporary construction loads which cause stresses beyond design limits are not permitted. Erection bracing shall be provided to keep the BCI® joists straight and plumb as required and to assure adequate lateral support for the individual BCI® joists and the entire system until the sheathing material has been applied.

**Codes** — The BCI® joists shall be evaluated by a model code evaluation service.

# Residential Floor Span Tables

## About Floor Performance

Homeowner's expectations and opinions vary greatly due to the subjective nature of rating a new floor. Communication with the ultimate end user to determine their expectation is critical. **Vibration** is usually the cause of most complaints. Installing lateral bridging may help; however, squeaks may occur if not installed properly. Spacing the joists closer together does little to affect the perception of the floor's performance. The most common methods used to increase the performance and reduce vibration of wood floor systems is to **increase the joist depth, limit joist**

**deflections, glue and screw a thicker, tongue-and-groove subfloor, install the joists vertically plumb with level-bearing supports, and install a direct-attached ceiling to the bottom flanges of the joists.**

The floor span tables listed below offer three very different performance options, based on performance requirements of the homeowner.

Joist Depth	BCI® Joist Series	★★★ THREE STAR ★★★					★★★★ FOUR STAR ★★★★★					CAUTION	★ MINIMUM STIFFNESS ALLOWED BY CODE ★					CAUTION
		Live Load deflection limited to L/480: The common industry and design community standard for residential floor joists, 33% stiffer than L/360 code minimum. However, floor performance may still be an issue in certain applications, especially with 9½" and 11⅞" deep joists without a direct-attached ceiling.																
		Live Load deflection limited to L/960+: In addition to providing a floor that is 100% stiffer than the three star floor, field experience has been incorporated into the values to provide a floor with a premium performance level for the more discriminating homeowner.					Live Load deflection limited to L/360: Floors that meet the minimum building code L/360 criteria are structurally sound to carry the specified loads; however, there is a much higher risk of floor performance issues. This table should only be used for applications where floor performance is not a concern.											
		12" o.c.	16" o.c.	19.2" o.c.	24" o.c.	32" o.c.	12" o.c.	16" o.c.	19.2" o.c.	24" o.c.	32" o.c.	12" o.c.	16" o.c.	19.2" o.c.	24" o.c.	32" o.c.		
9½"	4500s	16'-11"	15'-6"	14'-8"	13'-7"	11'-9"	11'-6"	11'-6"	10'-0"	10'-0"	9'-7"	18'-9"	16'-8"	15'-3"	13'-7"	11'-9"		
	5000s	17'-6"	16'-0"	15'-2"	14'-1"	12'-5"	11'-6"	11'-6"	10'-0"	10'-0"	9'-11"	19'-4"	17'-9"	16'-4"	14'-7"	12'-5"		
	6000s	18'-2"	16'-8"	15'-8"	14'-8"	13'-4"	11'-6"	11'-6"	10'-0"	10'-0"	10'-0"	20'-2"	18'-5"	17'-5"	15'-9"	13'-8"		
	6500s	18'-8"	17'-1"	16'-1"	15'-0"	13'-8"	11'-6"	11'-6"	10'-0"	10'-0"	10'-0"	20'-8"	18'-11"	17'-10"	16'-7"	14'-3"		
11⅞"	4500s	20'-0"	18'-4"	17'-3"	15'-5"	13'-4"	15'-6"	14'-3"	13'-5"	12'-6"	11'-4"	21'-10"	18'-11"	17'-3"	15'-5"	13'-4"		
	5000s	20'-9"	19'-0"	17'-11"	16'-7"	13'-4"	15'-6"	14'-9"	13'-11"	12'-11"	11'-9"	23'-0"	20'-4"	18'-6"	16'-7"	13'-4"		
	6000s	21'-7"	19'-8"	18'-7"	17'-4"	14'-10"	15'-6"	15'-4"	14'-5"	13'-5"	12'-1"	23'-10"	21'-10"	20'-0"	17'-11"	14'-10"		
	6500s	22'-2"	20'-3"	19'-2"	17'-10"	14'-10"	16'-0"	15'-10"	14'-11"	13'-10"	12'-7"	24'-6"	22'-5"	21'-1"	18'-10"	14'-10"		
	60s	23'-7"	21'-6"	20'-4"	18'-11"	16'-4"	18'-0"	16'-9"	15'-9"	14'-8"	13'-3"	26'-1"	23'-10"	22'-6"	21'-0"	16'-4"		
14"	4500s	22'-9"	20'-7"	18'-9"	16'-9"	13'-11"	17'-10"	16'-3"	15'-4"	14'-3"	13'-0"	23'-10"	20'-7"	18'-9"	16'-9"	13'-11"		
	5000s	23'-7"	21'-7"	20'-2"	18'-0"	13'-11"	18'-6"	16'-10"	15'-11"	14'-9"	13'-5"	25'-7"	22'-1"	20'-2"	18'-0"	13'-11"		
	6000s	24'-6"	22'-5"	21'-2"	19'-6"	15'-5"	19'-2"	17'-6"	16'-6"	15'-4"	13'-11"	27'-1"	23'-11"	21'-10"	19'-6"	15'-5"		
	6500s	25'-2"	23'-0"	21'-8"	20'-2"	15'-5"	19'-8"	17'-11"	16'-11"	15'-8"	14'-3"	27'-9"	25'-2"	22'-11"	20'-6"	15'-5"		
	60s	26'-9"	24'-5"	23'-0"	21'-5"	16'-4"	20'-11"	19'-0"	17'-11"	16'-7"	15'-1"	29'-7"	27'-0"	25'-6"	21'-10"	16'-4"		
16"	4500s	30'-1"	27'-5"	25'-10"	24'-0"	19'-6"	23'-6"	21'-4"	20'-0"	18'-6"	16'-9"	33'-3"	30'-4"	28'-7"	26'-0"	19'-6"		
	5000s	25'-2"	22'-0"	20'-1"	17'-11"	14'-1"	19'-9"	18'-0"	17'-0"	15'-10"	14'-1"	25'-5"	22'-0"	20'-1"	17'-11"	14'-1"		
	6000s	27'-0"	24'-9"	23'-4"	20'-10"	15'-9"	21'-2"	19'-4"	18'-2"	16'-11"	15'-4"	29'-6"	25'-6"	23'-4"	20'-10"	15'-9"		
	6500s	27'-9"	25'-4"	23'-11"	21'-1"	15'-9"	21'-9"	19'-9"	18'-8"	17'-4"	15'-8"	30'-8"	26'-11"	24'-6"	21'-1"	15'-9"		
	60s	29'-7"	27'-0"	25'-6"	21'-10"	16'-4"	23'-2"	21'-1"	19'-10"	18'-5"	16'-4"	32'-8"	29'-10"	27'-4"	21'-10"	16'-4"		
90s	33'-4"	30'-4"	28'-7"	26'-2"	19'-7"	26'-0"	23'-7"	22'-2"	20'-6"	18'-7"	36'-10"	33'-7"	31'-8"	26'-2"	19'-7"			

- ▶ Tables are based on
  - residential floor load of 40 psf live load and 10 psf dead load (12 psf dead load for 90s 2.0 joists).
  - 23/32" minimum plywood/OSB rated sheathing glued and nailed to joists for composite action (joists spaced at 32" o.c. require sheathing rated for such spacing, such as 7/8" plywood/OSB).
  - the most restrictive of simple or multiple span applications. Analyze multiple span joists with BC Calc® sizing software if the length of any span is less than half the length of an adjacent span.
  - maximum allowable clear distance between supports.
  - minimum bearing lengths without web stiffeners for joist depths of 16" and less.

- ▶ Floor tile will increase dead load and may require specific deflection limits, contact Boise Cascade EWP Engineering for further information.
- ▶ This table was designed to apply to a broad range of applications. It may be possible to exceed the limitations of this table by analyzing a specific application with the BC Calc® sizing software.

**Gold-shaded** values may not satisfy the requirements of the North Carolina State Building Code. Refer to the THREE STAR table when spans exceed 20 feet.

## One-Hour Fire Resistance Assembly (ICC-ES/APA ESR-1336)

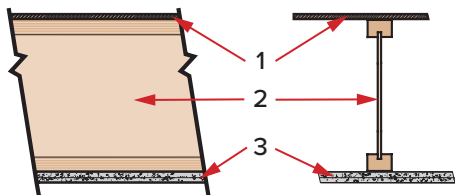

### Fire Assembly Components

- (1) Min. 23/32" thick tongue and groove sheathing (exterior glue), installed with long edge perpendicular to joist length, staggered one joist spacing with adjacent sheets, and glued to joists with construction adhesive.
- (2) BCI® joists at 24" o.c. or less.
- (3) Two layers 5/8" Type X or two layers 1/2" Type C gypsum board, installed per Figures 2 or 3 of ICC-ES®/APA® ESR-1336.

### Sound Assembly Components (when constructed with resilient channels)

- Add carpet and pad to fire assembly STC=54 IIC=68 or
- Add 3½" glass fiber insulation to fire assembly STC=55 IIC=46 or
- Add an additional layer of minimum 5/8" sheathing and 9½" glass fiber insulation to fire assembly STC=61 IIC=50

See the US version of the *Boise Cascade Fire Design and Installation Guide* for specific assembly information and other fire resistance assemblies and details.

# Floor Framing

The illustration below is showing several suggested applications for Boise Cascade EWP products. It is not intended to show an actual house under construction.

**NO MIDSPAN BRIDGING IS REQUIRED FOR BCI® JOISTS**

### FOR INSTALLATION STABILITY:

Temporary strut lines (1x4 min.) 8' o.c. max. Fasten at each joist with two 8d nails minimum.

**F01 F02**

BCI® rim joist

**F07 F07A F56**

Boise Cascade® Rimboard; see Rim Board Details in this guide.

Dimension lumber is not suitable for use as a rim board in BCI® floor systems.

**F05**

For information on load-bearing cantilevers, see Cantilever section in this guide

**F06 F09**

BCI® blocking or 2x4 squash block on each side is required when supporting a load-bearing wall above.

1½" knockout holes at approximately 12" o.c. are pre-punched.

Versa-Lam® LVL header or BCI® joist header

**F27A F10 F16E**

**F58**

**F15B**

**F27A**

Versa-Lam® LVL beam

End-wall blocking as required per governing building code

BCI® blocking is required when joist is cantilevered

See BCI® joist hole locations and sizing

### SAFETY WARNING

**DO NOT** allow workers on BCI® joists until all hangers, BCI® rim joists, rim boards, BCI® blocking panels, x-bracing and temporary 1x4 strut lines are installed as specified below. Serious accidents can result from insufficient attention to proper bracing during construction. Accidents can be avoided under normal conditions by following these guidelines:

- ▶ Build a braced end wall at the end of the bay, or permanently install the first eight feet of BCI® joists and the first course of sheathing. As an alternate, temporary sheathing may be nailed to the first four feet of BCI® joists at the end of the bay.
- ▶ All rim joists, rim boards, x-bracing, blocking panels and hangers must be completely installed and properly nailed as each BCI® joist is set.
- ▶ Install temporary 1x4 strut lines at 8' on-center or closer as additional BCI® joists are set. Nail the strut lines to the sheathed area or braced end wall, and to each BCI® joist with two 2½" (8d) nails.
- ▶ The ends of cantilevers must be temporarily secured by strut lines on both the top and bottom flanges.
- ▶ Straighten the BCI® joists to within ½" of true alignment before attaching strut lines and sheathing.
- ▶ Remove the temporary strut lines only as required to install the permanent sheathing.
- ▶ Failure to install temporary bracing may result in sideways buckling or roll-over under light construction loads.
- ▶ Do not stack construction materials (sheathing, drywall, etc.) in the middle of BCI® joist spans. Contact Boise Cascade EWP Engineering for proper storage and shoring information.

### Nailing Requirements

- ▶ **BCI® rim joist, rim board or closure panel to BCI® joist:**
  - **Rim or closure panel:** Two nails, one each in the top and bottom flange. For rim 1-1/2" thick or less, use 8d x 2½" nails; 1¾" thick rim, use 10d x 3" box nails.
  - **BCI® 4500s/5000s rim joist:** Two 10d box nails, one each in the top and bottom flange.
  - **BCI® 6000s/60s rim joist:** Two 16d box nails, one each in the top and bottom flange.
  - **BCI® 6500s/90s rim joist:** Toe-nail top flange to rim joist with two 10d box nails, one each side of flange.
- ▶ **BCI® rim joist, rim board or BCI® blocking panel to support:**
  - Min. 8d nails at 6" o.c. per IRC®.
  - Connect per design professional of record's specification for shear transfer.
- ▶ **BCI® joist to support:**
  - Two 8d nails, one on each side of the web, placed 1½" minimum from the end of the BCI® joist to limit splitting.
- ▶ **Sheathing to BCI® joist:**
  - Prescriptive nailing for residential floor sheathing requires 8d common nails at 6" o.c. at edges and 12" o.c. in the field (IRC® Table R602.3(1)).
  - See Closest Allowable Nail Spacing limits on page 24 for floor diaphragm nailing specified at closer spacing than IRC®.
  - For full lateral stability, maximum nail spacing for bracing is 18" for BCI® 4500s and 5000s, and 24" for larger BCI® joist series.
  - 14 gauge staples may be substituted for 8d nails if the staples penetrate at least 1" into the joist.
  - Wood screws may be acceptable, contact local building official and/or Boise Cascade EWP Engineering for more information.

### BCI® Joist Slope Cut Reinforcement

Detail below restores the original allowable shear/ reaction value to cut end of BCI® joist. BCI® joists shall not be used as a collar or rafter tension tie.

Rafter (2 x 6 min.) shall be supported by ridge beam or other upper bearing support

**F14**

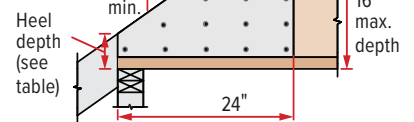

2x blocking required at bearing (not shown for clarity). 2½/₃₂" min. plywood/OSB-rated sheathing as reinforcement. Install reinforcement with face grain horizontal. Install on both sides of the joist, tight to bottom flange. Leave minimum ¼" gap between reinforcement and bottom of top flange. Apply construction adhesive to contact surfaces and fasten with 3 rows of min. 10d box nails at 6" o.c. Alternate nailing from each side and clinch.

End Wall Bearing	Minimum Heel Depth					
	6:12	7:12	8:12	9:12	10:12	12:12
2 x 4	4¾"	4⅝"	4¼"	4¼"	4¼"	4¼"
2 x 6	3⅝"	3⅜"	2⅝"	2¾"	2⅞"	2¼"

### PROTECT BCI® JOISTS FROM THE WEATHER

BCI® joists are intended only for applications that provide permanent protection from the weather. Product bundles should be covered and stored off of the ground on stickers. Also see **PRODUCT STORAGE AND HANDLING** on page 2.

# Floor Framing Details

## End Bearing Details

**F07**

**Dimension lumber is not suitable for use as rim board with BCI joists.**

Rim board: Nail to BCI joists with 2½" (8d) nail into each flange.

**F07A**

**Dimension lumber is not suitable for use as rim board with BCI joists.**

Blocking may be required perpendicular to wall, consult design professional of record and/or local building official.

**F01**

BCI joist blocking

**F02**

BCI rim joist

BCI rim joist requires 2x6 wall for minimum bearing

**F27A**

Top flange or face mount joist hanger

Versa-Lam® LVL

**F52**

One 8d nail each side at bearing

1½" minimum bearing length

To limit splitting flange, start nails at least 1½" from end. Nails may need to be driven at an angle to limit splitting of bearing plate.

**F08**

Use solid blocking under all posts above for support to the bearing plate.

**F03**

Boise Cascade® rimboard

BCI floor joist must be designed to carry wall above when not stacked over wall below.

Blocking required underneath braced wall panels and shear walls. Consult design profession of record.

## Intermediate Bearing Details

**F06**

For load bearing wall above (stacked over wall below)

BCI joist blocking

Per IRC, blocking may be required at intermediate bearing for floor diaphragm in high seismic areas; consult local building official.

**F09**

Load bearing wall above (stacked over wall below)

2x block

Double Squash Block Vertical Load (lb/ft)				
Size	Joist Spacing			
	12"	16"	19.2"	24"
2x4	4,463	3,347	2,789	2,231
2x6	7,013	5,259	4,383	3,506

- Squash blocks are to be in full contact with upper floor and lower wall plate.
- Capacities shown are for double squash blocks at each joist, SPF or better.

**F10**

Backer block (minimum 12" wide). Nail with ten 10d nails.

Joist hanger

Filler block. Nail with ten 10d nails.

A backer block is required where the top flange hanger load exceeds 250 lbs. All face mount hangers require backer blocks on both sides of the supporting joist's web. For top flange hangers install tight to top flange. For face mount hangers, install tight to the bottom flange.

**F58**

**Double BCI Joist Connection**

Filler block (if required).

Web filler nailing

- Filler block not required when all loads are top loaded and evenly applied to each ply (except BCI 90 joist).
- Side loads or uneven top loads require filler block.
- Fasten floor sheathing to each ply per diaphragm nailing schedule.

See BC Tech Note 1J-13 for more information on nailing and filler block requirements.

**F05**

Sheathing or rim board closure

BCI joist blocking required for cantilever

For load bearing cantilever, see page 9. Uplift on backspan shall be considered in all cantilever designs.

**Lateral Support**

- BCI joists shall be laterally supported at the ends with hangers, rim board, BCI rim joists or blocking panels. BCI blocking panels or rim board are required at cantilever supports.
- Per IRC, blocking may be required at intermediate bearings for floor diaphragm in high seismic areas, consult local building official.

**Minimum Bearing Length For BCI Joists**

- 1½" is required at end supports. 3½" is required at cantilever and intermediate supports.
- Longer bearing lengths allow higher reaction values. Refer to the building code evaluation report or the BC Calc software.

**Web Stiffeners**

- See Web Stiffener Requirements on page 9.

### Backer and Filler Block Dimensions

Series	Backer Block Thickness	Filler Block Thickness
4500s	5/8" or 3/4" wood panels	Two 5/8" wood panels or 2 x _
5000s	3/4" or 7/8" wood panels	Two 3/4" wood panels or 2 x _
6000s	1 1/8" or two 1/2" wood panels	2 x _ + 7/16" or 1/2" wood panel
6500s	1 1/8" or two 5/8" wood panels	2 x _ + 5/8" or 3/4" wood panel
60s	1 1/8" or two 1/2" wood panels	2 x _ + 7/16" or 1/2" wood panel
90s	2 x _ lumber	Double 2 x _ lumber

► Cut backer and filler blocks to a maximum depth equal to the web depth minus ¼" to avoid a forced fit.

### BCI Rim Joists and Blocking

Depth	Series	Vertical Load Capacity (PLF)	
		No W.S. <sup>(1)</sup>	W.S. <sup>(2)</sup>
9½"	4500s, 5000s, 6000s, 6500s	2,300	N/A
	4500s, 5000s, 6000s, 6500s	2,150	N/A
11 7/8"	60s, 90s	2,500	N/A
	4500s, 5000s, 6000s, 6500s	2,000	N/A
14"	60s, 90s	2,400	N/A
	4500s, 6000s, 6500s	1,900	2,500
16"	60s, 90s	2,300	2,700

(1) No web stiffeners required.

(2) Web stiffeners required at each end of blocking panel, values not applicable to rim joists.

N/A: Not applicable

# Hole Location and Sizing

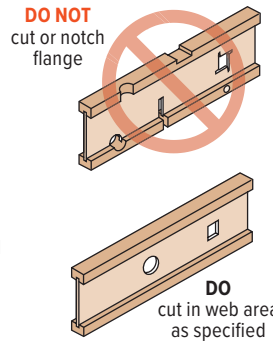
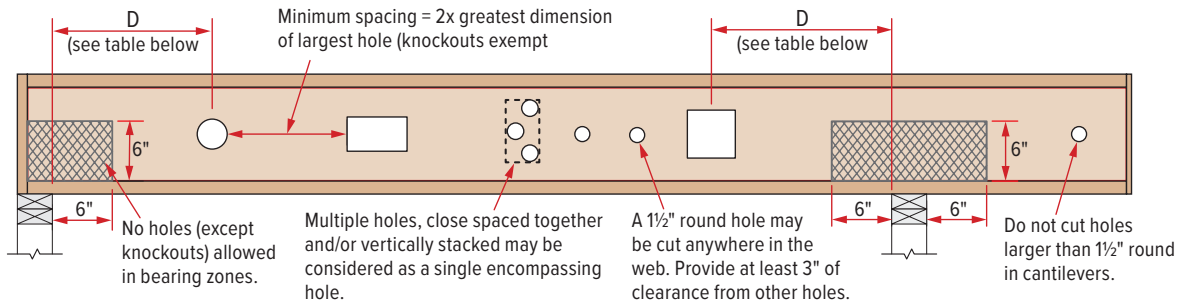

BCI® joists are manufactured with 1½" round perforated knockouts in the web at approximately 12" o.c. Minimum distance from support, listed in table below, is required for all holes greater than 1½".

Minimum Distance (D) From Any Support To The Centerline Of The Hole																
Round Hole Diameter	2"	3"	4"	5"	6"	6½"	7"	8"	8¾"	9"	10"	11"	12"	13"		
Rectangular Hole Side	-	-	-	3"	5"	6"	7"	-	-	-	-	-	-	-		
Any 9½" Joist	Span	8'	1'-0"	1'-1"	1'-5"	2'-1"	2'-9"	3'-1"	3'-5"							
		12'	1'-0"	1'-2"	2'-2"	3'-2"	4'-2"	4'-8"	5'-2"							
		16'	1'-0"	1'-7"	2'-11"	4'-3"	5'-7"	6'-3"	6'-11"							
Round Hole Diameter	2"	3"	4"	5"	6"	6½"	7"	8"	8¾"	9"	10"	11"	12"	13"		
Rectangular Hole Side	-	-	-	2"	3"	4"	5"	7"	8"	-	-	-	-	-		
Any 11⅞" Joist	Span	8'	1'-0"	1'-1"	1'-5"	1'-10"	2'-4"	2'-7"	2'-10"	3'-4"	3'-9"					
		12'	1'-0"	1'-4"	2'-1"	2'-10"	3'-7"	3'-11"	4'-3"	5'-0"	5'-8"					
		16'	1'-0"	1'-10"	2'-10"	3'-9"	4'-9"	5'-3"	5'-9"	6'-9"	7'-7"					
		20'	1'-1"	2'-3"	3'-6"	4'-9"	5'-11"	6'-7"	7'-2"	8'-5"	9'-6"					
Round Hole Diameter	2"	3"	4"	5"	6"	6½"	7"	8"	8¾"	9"	10"	11"	12"	13"		
Rectangular Hole Side	-	-	-	-	2"	3"	3"	5"	6"	6"	8"	9"	-	-		
Any 14" Joist	Span	8'	1'-0"	1'-1"	1'-2"	1'-3"	1'-8"	1'-10"	2'-1"	2'-6"	2'-10"	2'-11"	3'-4"	3'-8"		
		12'	1'-0"	1'-1"	1'-3"	1'-10"	2'-6"	2'-10"	3'-1"	3'-9"	4'-3"	4'-4"	5'-0"	5'-7"		
		16'	1'-0"	1'-1"	1'-8"	2'-6"	3'-4"	3'-9"	4'-2"	5'-0"	5'-8"	5'-10"	6'-8"	7'-5"		
		20'	1'-0"	1'-1"	2'-1"	3'-2"	4'-2"	4'-8"	5'-2"	6'-3"	7'-2"	7'-3"	8'-4"	9'-4"		
		24'	1'-0"	1'-4"	2'-6"	3'-9"	5'-0"	5'-8"	6'-3"	7'-6"	8'-7"	8'-9"	10'-0"	11'-2"		
Round Hole Diameter	2"	3"	4"	5"	6"	6½"	7"	8"	8¾"	9"	10"	11"	12"	13"		
Rectangular Hole Side	-	-	-	-	-	-	2"	3"	5"	5"	6"	8"	9"	10"		
Any 16" Joist	Span	8'	1'-0"	1'-1"	1'-2"	1'-2"	1'-3"	1'-3"	1'-3"	1'-7"	1'-11"	2'-0"	2'-5"	2'-9"	3'-2"	3'-7"
		12'	1'-0"	1'-1"	1'-2"	1'-2"	1'-3"	1'-6"	1'-10"	2'-5"	2'-11"	3'-0"	3'-7"	4'-2"	4'-9"	5'-4"
		16'	1'-0"	1'-1"	1'-2"	1'-2"	1'-8"	2'-1"	2'-6"	3'-3"	3'-11"	4'-0"	4'-10"	5'-7"	6'-4"	7'-2"
		20'	1'-0"	1'-1"	1'-2"	1'-2"	2'-1"	2'-7"	3'-1"	4'-1"	4'-11"	5'-1"	6'-0"	7'-0"	8'-0"	8'-11"
		24'	1'-0"	1'-1"	1'-2"	1'-4"	2'-6"	3'-1"	3'-9"	4'-11"	5'-11"	6'-1"	7'-3"	8'-5"	9'-7"	10'-9"

## HOW TO USE THIS TABLE

- Select a table row based on joist depth and the actual joist span rounded up to the nearest span shown in the table.
- Scan across the row to the column for the appropriate round hole diameter or rectangular hole side. Use the longest side of a rectangular hole.
- The table value shown is the closest that the centerline of the hole may be to the edge or face of the nearest support.

## NOTES

- ▶ **DO NOT** cut joist flanges.
- ▶ Holes apply to either single or multiple joists in repetitive member conditions.
- ▶ For multiple holes, the amount of horizontal uncut web between holes must equal at least twice the diameter (or longest side) of the largest hole.
- ▶ Table assumes one hole per horizontal location. Holes located above or below another should be considered as a single hole that encompasses all the holes.
- ▶ 1½" round knockouts in the web may be removed by using a short piece of metal pipe and hammer.
- ▶ Single holes may be positioned anywhere vertically in the web, provided they do not extend into either flange.
- ▶ This table was designed to apply *only* to the design conditions covered by tables elsewhere in this publication (maximum uniform PLF load).
- ▶ Use the BC Calc® software to check other hole sizes or holes in other design conditions. It may be possible to exceed the limitations of this table by analyzing a specific application with the BC Calc® software.

# Large Rectangular Holes

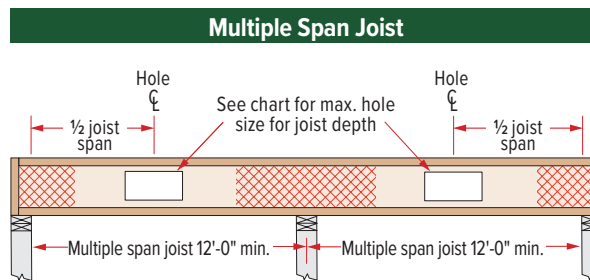
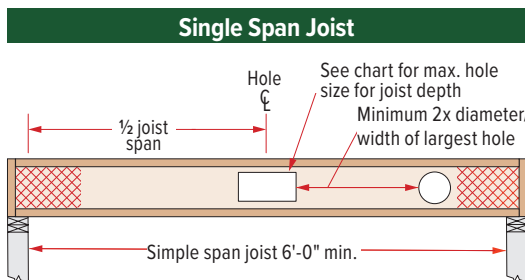

## Maximum Hole Size

Joist Depth	Simple Span	Multiple Span
9½"	6" x 14"	6" x 12"
11⅞"	7" x 16" 8" x 15"	8" x 12"
14"	9" x 16" 10" x 15"	8" x 15"
16"	9" x 18" 11" x 16"	10" x 14"

Larger holes may be possible for either single or multiple span joists; use BC Calc® sizing software for specific analysis.

- ▶ Hole sizes in table below are based on maximum uniform load of 40 psf live load and 10 psf dead load, at maximum spacing of 24" on-center.
- ▶ Additional holes may be cut in the web provided they meet the specifications shown in the Minimum Distance hole chart above or as allowed using BC Calc® sizing software.

# BCI Joists – Reinforced Load-Bearing Cantilevers

Joist Depth	Joist Series	Roof Truss Span	Roof Total Load (psf)																				
			35			45			55														
			Joist Spacing (inches)																				
			16	19.2	24	16	19.2	24	16	19.2	24												
9 1/2"	4500s	24'	0	0	0	0	0	X	0	X	X	24'	0	0	0	0	0	0	0	0	1		
		26'	0	0	0	0	0	X	0	X	X	26'	0	0	0	0	0	0	0	0	X		
		28'	0	0	X	0	X	X	X	X	X	28'	0	0	0	0	0	0	0	0	X		
		30'	0	0	X	0	X	X	X	X	X	30'	0	0	0	0	0	1	0	0	X		
		32'	0	0	X	0	X	X	X	X	X	32'	0	0	0	0	0	1	0	0	X		
		34'	0	0	X	0	X	X	X	X	X	34'	0	0	0	0	0	X	0	1	X		
		36'	0	X	X	X	X	X	X	X	X	36'	0	0	0	0	0	X	0	1	X		
		38'	0	X	X	X	X	X	X	X	X	38'	0	0	0	0	0	X	0	1	X		
		40'	0	X	X	X	X	X	X	X	X	40'	0	0	1	0	0	X	0	X	X		
		42'	0	X	X	X	X	X	X	X	X	42'	0	0	0	0	0	0	0	0	1		
		5000s	24'	0	0	0	0	0	X	0	X	X	24'	0	0	0	0	0	0	0	0	1	
			26'	0	0	0	0	0	X	0	X	X	26'	0	0	0	0	0	0	0	0	1	
28'	0		0	1	0	X	X	X	X	X	28'	0	0	0	0	0	WS	0	0	X			
30'	0		0	1	0	X	X	X	X	X	30'	0	0	0	0	0	1	0	0	X			
32'	0		0	X	0	X	X	X	X	X	32'	0	0	0	0	0	1	0	1	X			
34'	0		0	X	X	X	X	X	X	X	34'	0	0	0	0	0	X	0	1	X			
36'	0		0	X	X	X	X	X	X	X	36'	0	0	WS	0	0	X	0	1	X			
38'	0		X	X	X	X	X	X	X	X	38'	0	0	1	0	0	X	0	1	X			
40'	0		X	X	X	X	X	X	X	X	40'	0	0	1	0	1	X	1	X	X			
6000s	24'		0	0	0	0	0	0	0	X	X	24'	0	0	0	0	0	0	0	0	0		
	26'		0	0	0	0	0	X	0	X	X	26'	0	0	0	0	0	0	0	0	0		
	28'		0	0	0	0	0	X	X	X	X	28'	0	0	0	0	0	0	0	0	0		
	30'	0	0	0	0	0	X	X	X	X	30'	0	0	0	0	0	0	0	0	0			
	32'	0	0	0	0	0	X	X	X	X	32'	0	0	0	0	0	0	0	0	0			
	34'	0	0	X	0	X	X	X	X	X	34'	0	0	0	0	0	0	0	0	1			
	36'	0	0	X	0	X	X	X	X	X	36'	0	0	0	0	0	0	0	0	1			
	38'	0	0	X	X	X	X	X	X	X	38'	0	0	X	X	X	X	X	X	X			
	40'	0	0	X	X	X	X	X	X	X	40'	0	0	0	0	0	0	0	0	2			
	6500s	24'	0	0	0	0	0	0	0	0	X	24'	0	0	0	0	0	0	0	0	WS		
		26'	0	0	0	0	0	0	0	X	X	26'	0	0	0	0	0	WS	0	0	WS		
		28'	0	0	0	0	0	0	0	X	X	28'	0	0	0	0	0	WS	0	0	1		
30'		0	0	0	0	0	X	0	X	X	30'	0	0	0	0	0	WS	0	WS	X			
32'		0	0	0	0	0	X	0	X	X	32'	0	0	0	0	0	WS	0	WS	X			
34'		0	0	0	0	0	X	X	X	X	34'	0	0	WS	0	0	1	0	WS	X			
36'		0	0	X	0	X	X	X	X	X	36'	0	0	WS	0	0	X	0	WS	X			
38'		0	0	X	X	X	X	X	X	X	38'	0	0	WS	0	WS	X	0	X	X			
40'		0	0	X	0	X	X	X	X	X	40'	0	0	WS	0	WS	X	WS	X	X			
9 1/2"		4500s	24'	0	0	0	0	0	WS	0	0	X	24'	0	0	0	0	0	WS	0	0	WS	
			26'	0	0	0	0	0	WS	0	0	X	26'	0	0	0	0	0	WS	0	0	WS	
			28'	0	0	0	0	0	X	0	WS	X	28'	0	0	0	0	0	WS	0	0	1	
	30'		0	0	0	0	0	X	0	WS	X	30'	0	0	0	0	0	WS	0	0	WS		
	32'		0	0	WS	0	0	X	0	X	X	32'	0	0	WS	0	0	WS	0	WS	2		
	34'		0	0	WS	0	0	X	0	X	X	34'	0	0	WS	0	WS	1	0	WS	X		
	36'		0	0	WS	0	WS	X	0	X	X	36'	0	0	WS	0	WS	1	0	WS	X		
	38'		0	0	X	0	X	X	X	X	X	38'	0	0	WS	0	WS	1	WS	1	X		
	40'		0	0	X	0	X	X	X	X	X	40'	0	0	WS	0	WS	2	WS	1	X		
	42'		0	0	X	0	X	X	X	X	X	42'	0	0	WS	0	WS	X	WS	X	X		
	11 1/8"		5000s	24'	0	0	0	0	0	WS	0	0	1	24'	0	0	0	0	0	WS	0	0	WS
				26'	0	0	0	0	0	WS	0	0	1	26'	0	0	0	0	0	WS	0	0	WS
28'		0		0	0	0	0	WS	0	0	X	28'	0	0	0	0	0	WS	0	0	WS		
30'		0		0	WS	0	0	1	0	0	X	30'	0	0	0	0	0	WS	0	0	1		
32'		0		0	WS	0	0	1	0	1	X	32'	0	0	0	0	0	WS	0	0	WS		
34'		0		0	WS	0	WS	X	0	X	X	34'	0	0	0	0	0	WS	0	WS	1		
36'		0		0	WS	0	WS	X	0	X	X	36'	0	0	WS	0	WS	0	WS	1			
38'		0		0	WS	0	WS	X	X	X	X	38'	0	0	WS	0	WS	1	0	1	2		
40'		0		0	1	0	1	X	X	X	X	40'	0	0	WS	0	WS	1	0	1	2		
6000s		24'		0	0	0	0	0	0	0	0	WS	24'	0	0	0	0	0	0	0	0	WS	
		26'		0	0	0	0	0	0	0	0	WS	26'	0	0	0	0	0	0	0	0	WS	
		28'		0	0	0	0	0	WS	0	0	X	28'	0	0	0	0	0	WS	0	0	WS	
	30'	0	0	WS	0	0	1	0	0	X	30'	0	0	0	0	0	WS	0	0	1			
	32'	0	0	WS	0	0	1	0	1	X	32'	0	0	0	0	0	WS	0	0	WS			
	34'	0	0	WS	0	WS	X	0	X	X	34'	0	0	0	0	0	WS	0	WS	1			
	36'	0	0	WS	0	WS	X	0	X	X	36'	0	0	WS	0	WS	0	WS	1				
	38'	0	0	WS	0	WS	X	X	X	X	38'	0	0	WS	0	1	0	1	2				
	40'	0	0	1	0	1	X	X	X	X	40'	0	0	WS	0	WS	1	0	1	2			
	6500s	24'	0	0	0	0	0	0	0	0	WS	24'	0	0	0	0	0	0	0	0	WS		
		26'	0	0	0	0	0	0	0	0	WS	26'	0	0	0	0	0	0	0	0	WS		
		28'	0	0	0	0	0	WS	0	0	X	28'	0	0	0	0	0	WS	0	0	WS		
30'		0	0	0	0	0	WS	0	0	X	30'	0	0	0	0	0	WS	0	0	1			
32'		0	0	0	0	0	WS	0	0	X	32'	0	0	0	0	0	WS	0	0	WS			
34'		0	0	0	0	0	WS	0	0	X	34'	0	0	0	0	0	WS	0	WS	1			
36'		0	0	0	0	0	WS	0	0	X	36'	0	0	WS	0	0	WS	0	WS	1			
38'		0	0	0	0	0	WS	0	0	X	38'	0	0	WS	0	1	0	1	2				
40'		0	0	1	0	1	X	X	X	X	40'	0	0	WS	0	WS	1	0	1	2			

Joist Depth	Joist Series	Roof Truss Span	Roof Total Load (psf)																				
			35			45			55														
			Joist Spacing (inches)																				
			16	19.2	24	16	19.2	24	16	19.2	24												
11 1/8"	6500s	24'	0	0	0	0	0	0	0	0	1	24'	0	0	0	0	0	0	0	0	1		
		26'	0	0	0	0	0	0	0	0	X	26'	0	0	0	0	0	0	0	0	X		
		28'	0	0	0	0	0	0	0	0	X	28'	0	0	0	0	0	0	0	0	X		
		30'	0	0	0	0	0	1	0	0	X	30'	0	0	0	0	0	1	0	0	X		
		32'	0	0	0	0	0	1	0	0	X	32'	0	0	0	0	0	1	0	0	X		
		34'	0	0	0	0	0	X	0	1	X	34'	0	0	0	0	0	X	0	1	X		
		36'	0	0	0	0	0	X	0	1	X	36'	0	0	0	0	0	X	0	1	X		
		38'	0	0	0	0	0	X	0	1	X	38'	0	0	0	0	0	X	0	1	X		
		40'	0	0	1	0	0	X	0	X	X	40'	0	0	1	0	0	X	0	X	X		
		14"	60s	24'	0	0	0	0	0	0	0	0	1	24'	0	0	0	0	0	0	0	0	1
				26'	0	0	0	0	0	0	0	0	1	26'	0	0	0	0	0	0	0	0	1
				28'	0	0	0	0	0	0	WS	0	X	28'	0	0	0	0	0	WS	0	0	X
30'	0			0	0	0	0	1	0	0	X	30'	0	0	0	0	0	1	0	0	X		
32'	0			0	0	0	0	1	0	1	X	32'	0	0	0	0	0	1	0	1	X		
34'	0			0	0	0	0	X	0	1	X	34'	0	0	0	0	0	X	0	1	X		
36'	0			0	WS	0	0	X	0	1	X	36'	0	0	WS	0	0	X	0	1	X		
38'	0			0	1	0	0	X	0	1	X	38'	0	0	1	0	0	X	0	1	X		
40'	0			0	1	0	1	X	1	X	X	40'											

# Reinforced Load-Bearing Cantilever Details

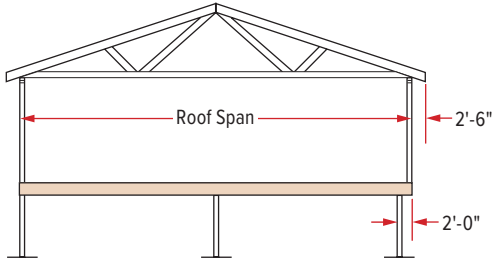

► The tables and details on pages 8 and 9 indicate the type of reinforcements, if any, that are required for load-bearing cantilevers up to a maximum length of 2'-0". Cantilevers longer than 2'-0" cannot be reinforced. However, longer cantilevers with lower loads may be allowable without reinforcement. Analyze specific applications with the BC Calc® software.

## PLYWOOD / OSB REINFORCEMENT (If required, per table on page 8 or per BC Calc® analysis)

- 2<sup>3</sup>/<sub>32</sub>" min. x 48" long plywood/OSB rated sheathing must match the full depth of the BCI® joist. Nail to the BCI® joist with 8d nails at 6" o.c. and nail with 4-8d nails into backer block. When reinforcing both sides, stagger nails to limit splitting. Install with face grain horizontal.
- The tables on page 8 assume a wall weight of 100 PLF, in addition to the roof loading shown. Applications with loading that exceeds the loads shown shall be analyzed with BC Calc® software.

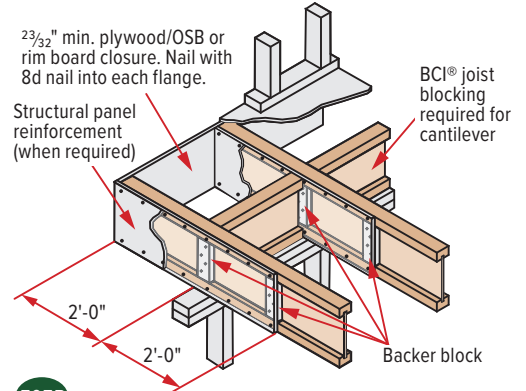

Uplift on back span shall be considered in all cantilever designs

# Non-Load-Bearing Wall Cantilever Details

► BCI® Joists are intended only for applications that provide permanent protection from the weather. Impervious moisture barrier systems shall be detailed and installed in details F15A and F15B in accordance with 2018 IBC® Sections 107.2.5 and 110.3.6.

► Fasten the 2x8 minimum to the BCI® joist by nailing through the backer block and joist web with two rows of 10d nails at 6" o.c. Clinch all nails. For BCI® 90s joists, use two rows of 16d nails on each side (four rows total) at 6" o.c.

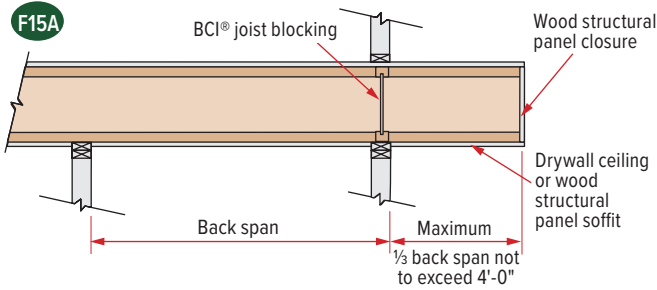

► These details apply to cantilevers with uniform loads only.  
► Analyze BCI® joist cantilever condition with BC Calc® software.

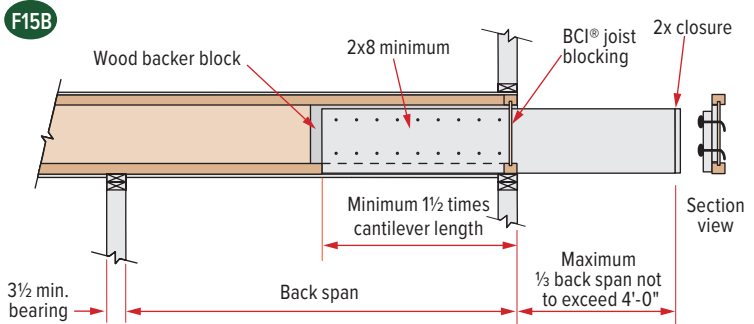

► Loading shall not exceed 60 psf live load and 10 psf dead load. At least three joist members shall be present and spaced at 24" o.c. or less.  
► Lumber joist shall be No. 2 Dense Southern Pine, No.1/No.2 SPF, No.2 Hem-fir, or No.2 Douglas fir, or higher grade.  
► Provide positive drainage, durable materials, and venting as required in 2018 IBC Sections 2304.12.2.5 and 2304.12.2.6. Lumber joist shall be sloped.

# Web Stiffener Requirements

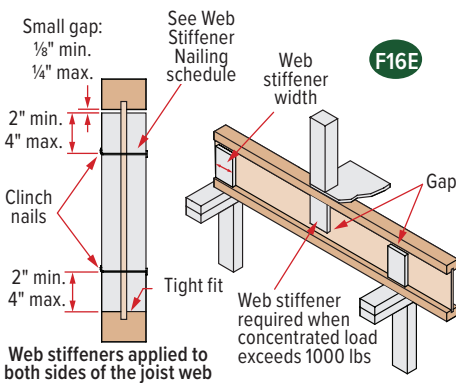

## Web Stiffener Specifications

BCI® Joist Series	For Structural Capacity (Min. Thick)	Lateral Restraint in Hanger	Minimum Width
4500s	5/8"	5/8"	2 <sup>5</sup> / <sub>16</sub> "
5000s	5/8"	3/4"	2 <sup>5</sup> / <sub>16</sub> "
6000s	3/4"	7/8"	2 <sup>5</sup> / <sub>16</sub> "
6500s	3/4"	1" or 1 <sup>1</sup> / <sub>8</sub> "	2 <sup>5</sup> / <sub>16</sub> "
60s	3/4"	7/8"	2 <sup>5</sup> / <sub>16</sub> "
90s	2x4 lumber (vertical)		

## NOTES

Web stiffeners are optional except as noted below.

- Web stiffeners are always required:
  - for all 18" and 20" joists at all bearing locations.
  - in hangers that do not extend up to support the top flange of the BCI® joist. Web stiffeners may be required with certain sloped or skewed hangers or to achieve uplift values. Refer to the hanger manufacturer's installation requirements.
  - in certain roof applications. See Roof Framing Details on page 14.
  - under concentrated loads that exceed 1000 pounds. Install the web stiffeners snug to the top flange in this situation. Follow the nailing schedule for intermediate bearings.
  - when hanger does not laterally support the top flange (e.g., adjustable height hangers). Web stiffeners may be of multiple thickness (e.g., BCI® 6500s, double 1/2" panel OK).
  - as needed for structural capacity, to increase the BCI® joist's reaction capacity at a specific bearing location.
- Web stiffeners may be cut from structural rated wood panels, engineered rimboard or 2x lumber (BCI® 90s only).
- Web stiffeners may be used to increase allowable reaction values. See BCI® Joist Design Properties on page 24 or use BC Calc® software.

## Web Stiffener Nailing Schedule

BCI® Joist Series	Depth	Bearing Location	
		End	Intermediate
4500s	9 1/2"	2-8d	2-8d
	11 7/8"	2-8d	3-8d
	14"	2-8d	5-8d
5000s	9 1/2"	2-8d	2-8d
	11 7/8"	2-8d	3-8d
	14"	2-8d	5-8d
6000s	9 1/2"	2-8d	2-8d
	11 7/8"	2-8d	3-8d
	14"	2-8d	5-8d
6500s	9 1/2"	2-8d	2-8d
	11 7/8"	2-8d	3-8d
	14"	2-8d	5-8d
60s	11 7/8"	2-8d	3-8d
	14"	2-8d	5-8d
	16"	2-8d	6-8d
90s	11 7/8"	3-16d	3-16d
	14"	5-16d	5-16d
	16"	6-16d	6-16d

# Floor Load Tables

## Allowable Uniform Floor Load (in pounds per lineal foot (PLF))

### 100% Load Duration

Span Length	BCI® 4500s 1.8 Joist 1¾" Flange Width								BCI® 5000s 1.8 Joist 2" Flange Width					
	9½"		11⅞"		14"		16"		9½"		11⅞"		14"	
	Live Load	Total Load	Live Load	Total Load	Live Load	Total Load	Live Load	Total Load	Live Load	Total Load	Live Load	Total Load	Live Load	Total Load
6	–	280	–	300	–	313	–	316	–	280	–	300	–	313
7	–	240	–	257	–	268	–	271	–	240	–	257	–	268
8	–	210	–	225	–	235	–	237	–	210	–	225	–	235
9	–	186	–	200	–	208	–	211	–	186	–	200	–	208
10	147	168	–	180	–	188	–	190	163	168	–	180	–	188
11	113	152	–	163	–	170	–	172	126	152	–	163	–	170
12	89	131	144	150	–	156	–	158	99	140	–	150	–	156
13	71	111	115	138	–	144	–	146	79	128	129	138	–	144
14	57	96	94	123	–	134	–	135	64	111	105	128	–	134
15	47	83	77	107	112	125	–	126	53	96	86	120	–	125
16			64	94	93	112	–	118	44	85	72	108	104	117
17			54	83	79	99	105	111			61	96	88	110
18			46	74	67	88	89	100			51	86	75	101
19					57	79	76	90			44	77	64	91
20					49	71	66	81					55	82
21					43	65	57	74					48	74
22							50	67					42	68
23							44	61						
24														
25														

**NOTES**

- ▶ This table was designed to apply to a broad range of applications. It may be possible to exceed the limitations of this table by analyzing a specific application with the BC Calc® software.
- ▶ Live Load values are limited by deflection equal to L/480. For deflection limits of L/360 and L/960, multiply the Live Load values by 1.33 and 0.50 respectively.
- ▶ Total Load values are limited by shear, moment, or deflection equal to L/240.
- ▶ Both the Total Load and Live Load columns must be checked. Where a Live Load value is not shown, the Total Load value will control.
- ▶ Total Load values assume minimum bearing lengths without web stiffeners for joist depths of 16" and less.
- ▶ Table values
  - apply to either simple or multiple span joists. Span is measured center to center of the minimum required bearing length. Analyze multiple span joists with the BC Calc® software if the length of any span is less than half the length of an adjacent span.
  - do not consider composite action from gluing and nailing floor sheathing (composite action is considered in floor span tables on page 4).
- ▶ For assistance with floor design, consult the section About Floor Performance on page 4.

# Floor Load Tables

Allowable Uniform Floor Load  
(in pounds per lineal foot (PLF))

## 100% Load Duration

Span Length	BCI® 6000s 1.8 Joist 2 <sup>5</sup> / <sub>16</sub> " Flange Width								BCI® 6500s 1.8 Joist 2 <sup>9</sup> / <sub>16</sub> " Flange Width							
	9½"		11⅞"		14"		16"		9½"		11⅞"		14"		16"	
	Live Load	Total Load	Live Load	Total Load	Live Load	Total Load	Live Load	Total Load	Live Load	Total Load	Live Load	Total Load	Live Load	Total Load	Live Load	Total Load
6	–	320	–	333	–	346	–	353	–	320	–	333	–	346	–	353
7	–	274	–	285	–	297	–	302	–	274	–	285	–	297	–	302
8	–	240	–	250	–	260	–	265	–	240	–	250	–	260	–	265
9	–	213	–	222	–	231	–	235	–	213	–	222	–	231	–	235
10	183	192	–	200	–	208	–	212	–	192	–	200	–	208	–	212
11	141	174	–	181	–	189	–	192	153	174	–	181	–	189	–	192
12	112	160	–	166	–	173	–	176	121	160	–	166	–	173	–	176
13	89	147	144	153	–	160	–	163	97	147	–	153	–	160	–	163
14	73	129	117	142	–	148	–	151	79	137	129	142	–	148	–	151
15	60	112	97	133	–	138	–	141	65	124	106	133	–	138	–	141
16	50	98	81	125	117	130	–	132	54	109	89	125	127	130	–	132
17	42	84	68	112	99	122	–	124	46	92	75	117	107	122	–	124
18			58	100	84	115	112	117			64	110	91	115	–	117
19			50	89	72	106	96	111			54	99	78	109	104	111
20			43	81	62	96	83	106			47	89	68	104	90	106
21					54	87	72	99			41	81	59	96	78	100
22					47	79	63	90					51	88	69	96
23					42	72	56	83					45	80	60	92
24							49	76					40	74	53	84
25							44	70							47	77
26															42	72
27																
28																
29																
30																

**NOTES**

- ▶ Total Load values are limited by shear, moment, or deflection equal to L/240.
- ▶ Live Load values are limited by deflection equal to L/480. For deflection limits of L/360 and L/960, multiply the Live Load values by 1.33 and 0.50 respectively.
- ▶ Both the Total Load and Live Load columns must be checked. Where a Live Load value is not shown, the Total Load value will control.
- ▶ Table values apply to either simple or multiple span joists. Span is measured center to center of the minimum required bearing length. Analyze multiple span joists with the BC Calc® software if the length of any span is less than half the length of an adjacent span.
- ▶ Table values do not consider composite action from gluing and nailing floor sheathing (composite action is considered in floor span tables on page 4).
- ▶ Total Load values assume minimum bearing lengths without web stiffeners for joist depths of 16" and less.
- ▶ For assistance with floor design, consult the section *About Floor Performance* on page 4.
- ▶ This table was designed to apply to a broad range of applications. It may be possible to exceed the limitations of this table by analyzing a specific application with the BC Calc® software.

# Floor Load Tables

Allowable Uniform Floor Load  
(in pounds per lineal foot (PLF))

## 100% Load Duration

Span Length	BCI® 60s 2.0 Joist 2 <sup>5</sup> / <sub>16</sub> " Flange Width						BCI® 90s 2.0 Joist 3 <sup>1</sup> / <sub>2</sub> " Flange Width					
	11 <sup>7</sup> / <sub>8</sub> "		14"		16"		11 <sup>7</sup> / <sub>8</sub> "		14"		16"	
	Live Load	Total Load	Live Load	Total Load	Live Load	Total Load	Live Load	Total Load	Live Load	Total Load	Live Load	Total Load
6	–	366	–	366	–	366	–	450	–	453	–	456
7	–	314	–	314	–	314	–	385	–	388	–	391
8	–	275	–	275	–	275	–	337	–	340	–	342
9	–	244	–	244	–	244	–	300	–	302	–	304
10	–	220	–	220	–	220	–	270	–	272	–	274
11	–	200	–	200	–	200	–	245	–	247	–	249
12	–	183	–	183	–	183	–	225	–	226	–	228
13	–	169	–	169	–	169	–	207	–	209	–	210
14	155	157	–	157	–	157	–	192	–	194	–	195
15	128	146	–	146	–	146	–	180	–	181	–	182
16	107	137	–	137	–	137	152	168	–	170	–	171
17	90	129	–	129	–	129	129	158	–	160	–	161
18	77	122	110	122	–	122	110	150	–	151	–	152
19	66	115	95	115	–	115	95	142	134	143	–	144
20	57	110	82	110	109	110	83	135	117	136	–	137
21	50	100	72	104	95	104	72	128	102	129	–	130
22	43	87	63	100	84	100	63	122	90	123	119	124
23			55	95	74	95	56	112	79	118	105	119
24			49	91	65	91	49	99	70	113	94	114
25			43	87	58	88	44	88	63	108	83	109
26					52	84			56	104	75	105
27					47	81			50	100	67	101
28					42	78			45	91	61	97
29									41	82	55	94
30											50	91

**NOTES**

- ▶ Total Load values are limited by shear, moment, or deflection equal to L/240.
- ▶ Live Load values are limited by deflection equal to L/480. For deflection limits of L/360 and L/960, multiply the Live Load values by 1.33 and 0.50 respectively.
- ▶ Both the Total Load and Live Load columns must be checked. Where a Live Load value is not shown, the Total Load value will control.
- ▶ Table values apply to either simple or multiple span joists. Span is measured center to center of the minimum required bearing length. Analyze multiple span joists with the BC Calc® software if the length of any span is less than half the length of an adjacent span.
- ▶ Table values do not consider composite action from gluing and nailing floor sheathing (composite action is considered in floor span tables on page 4).
- ▶ Total Load values assume minimum bearing lengths without web stiffeners for joist depths of 16" and less.
- ▶ For assistance with floor design, consult the section *About Floor Performance* on page 4.
- ▶ This table was designed to apply to a broad range of applications. It may be possible to exceed the limitations of this table by analyzing a specific application with the BC Calc® software.

# Roof Framing

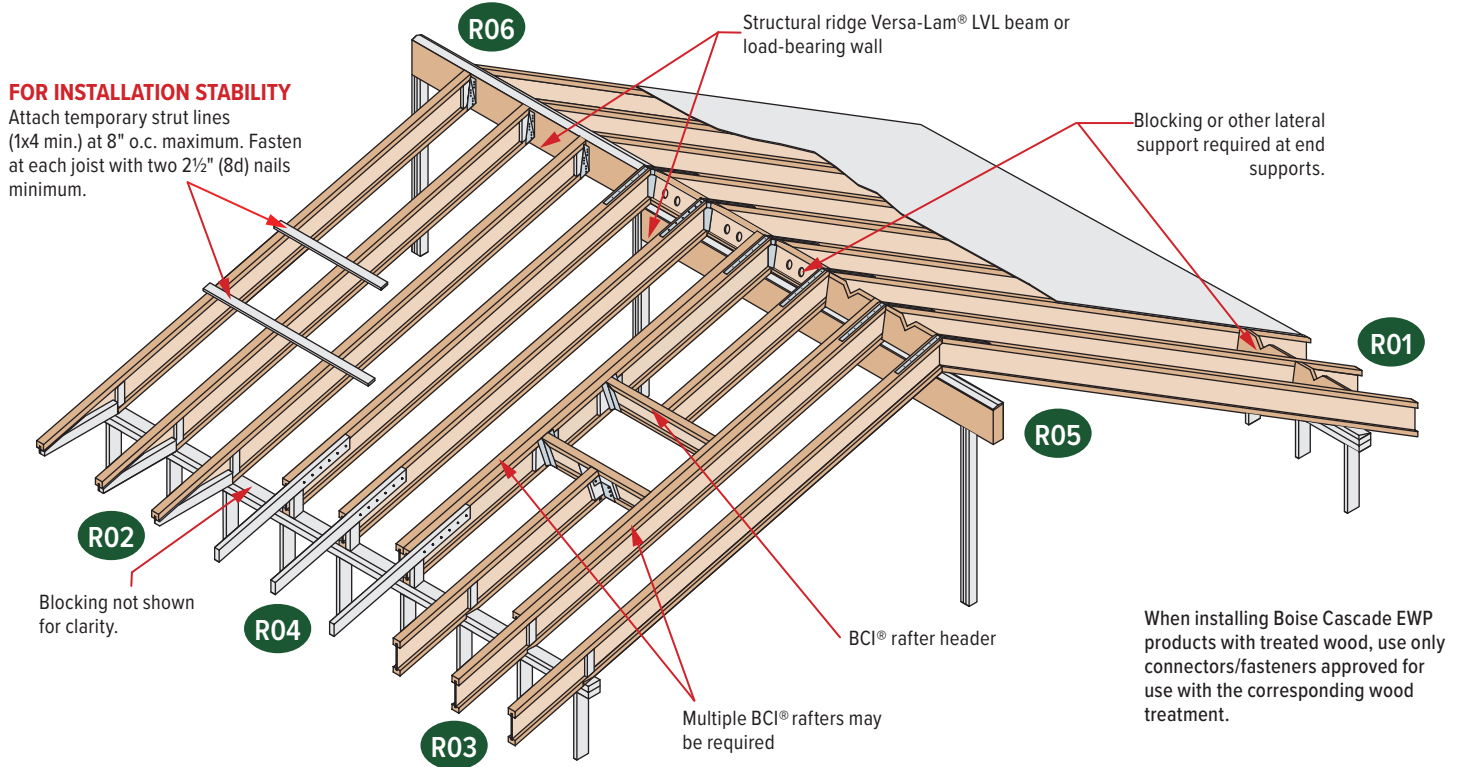

## SAFETY WARNING

**DO NOT ALLOW WORKERS ON BCI® JOISTS UNTIL ALL HANGERS, BCI® RIM JOISTS, RIM BOARDS, BCI® BLOCKING PANELS, X-BRACING AND TEMPORARY 1x4 STRUT LINES ARE INSTALLED AS SPECIFIED BELOW. SERIOUS ACCIDENTS CAN RESULT FROM INSUFFICIENT ATTENTION TO PROPER BRACING DURING CONSTRUCTION. ACCIDENTS CAN BE AVOIDED UNDER NORMAL CONDITIONS BY FOLLOWING THE GUIDELINES BELOW.**

- ▶ Build a braced end wall at the end of the bay, or permanently install the first eight feet of BCI® joists and the first course of sheathing. As an alternate, temporary sheathing may be nailed to the first four feet of BCI® joists at the end of the bay.
- ▶ All hangers, BCI® rim joists, rim boards, BCI® blocking panels, and x-bracing must be completely installed and properly nailed as each BCI® joist is set.
- ▶ Install temporary 1x4 strut lines at no more than eight feet on-center as additional BCI® joists are set. Nail the strut lines to the sheathed area, or braced end wall, and to each BCI® joist with two 2½" (8d) nails.
- ▶ The ends of cantilevers must be temporarily secured by strut lines on both the top and bottom flanges.
- ▶ Straighten the BCI® joist to within ½" of true alignment before attaching strut lines and sheathing.
- ▶ Remove the temporary strut lines only as required to install the permanent sheathing.
- ▶ Failure to install temporary bracing may result in sideways buckling or roll-over under light construction loads.

## BCI® Ceiling Joist with Bevel End Cut (For limited-access attics only)

**CAUTION:** DO NOT use BCI® joists as a collar/tension tie. Roof rafters shall be supported by ridge beam or other upper bearing support.

### NOTES:

- ▶ Ceiling joist must be designed to carry all roof load transferred through rafter struts as shown.
- ▶ BCI® ceiling joist end reaction may not exceed 550 pounds.
- ▶ Minimum roof slope is 6:12.
- ▶ Detail is to be used only for ceiling joists with no access to attic space.
- ▶ Nail roof rafter to BCI® top flange with one 3" (10d) sinker or box nail.
- ▶ 1x4 nailers must be continuous and nailed to a braced end wall.
- ▶ Install a web stiffener on each side of BCI® joist at beveled ends. Connect roof rafter to bearing per code.

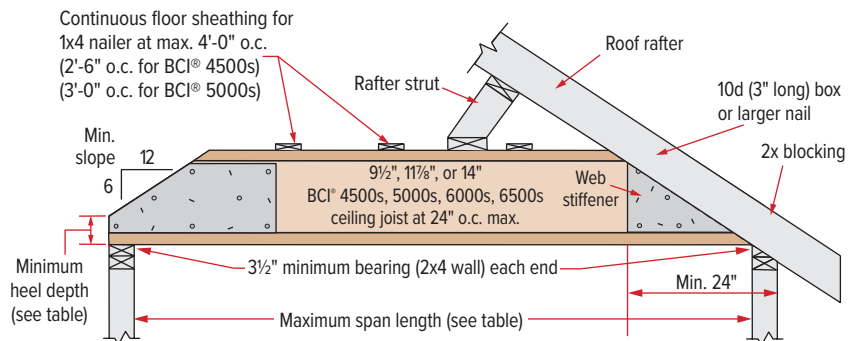

Ceiling loads: Live Load 10 psf, Dead Load 7 psf

### Minimum Heel Depths

Joist Depth	End Wall	
	2 x 4	2 x 6
9½"	2½"	1½"
11⅞"	3½"	2½"
14"	4½"	3½"

### Maximum Span Lengths Without Roof Loads

9½" BCI® 4500s/5000s/6000s/6500s	20'-0"
11⅞" BCI® 4500s/5000s/6000s/6500s	22'-6"
14" BCI® 4500s/5000s/6000s/6500s	24'-6"

▶ If roof loads are present, see first two notes at left.

# Roof Framing Details

## Additional roof framing details available with BC Framer® software

<p><b>R01</b></p> <p>2x beveled plate for slope greater than 1/4:12</p> <p>Simpson Strong-Tie VPA or MiTek TMP connectors or equal can be used in lieu of beveled plate for slopes from 3:12 to 12:12.</p>	<p><b>R02</b></p> <p>Rim board/Versa-Lam LVL blocking. Ventilation "V" cut: 1/3 of length, 1/2 of depth.</p> <p>2x4 blocking for soffit support</p> <p>16" max. joist depth for birdsmouth cut</p> <p>2'-6" max.</p> <p>BCI® joist flanges may be birdsmouth cut only at the low end of the joist, and cut flange must bear fully on plate. Web stiffener required on each side.</p>	<p><b>R03</b></p> <p>Rim board/Versa-Lam LVL blocking. Ventilation "V" cut: 1/3 of length, 1/2 of depth.</p> <p>Tight fit for lateral stability</p> <p>16" max. joist depth for birdsmouth cut</p> <p>2'-6" max.</p> <p>BCI® joist flanges may be birdsmouth cut only at the low end of the joist, and cut flange must bear fully on plate. Web stiffener required on each side.</p>
<p><b>R04</b></p> <p>10d nails at 6" o.c.</p> <p>2x4 one side for 135 PLF max. 2x6 one side for 240 PLF max.</p> <p>Backer block: Thickness per corresponding BCI® joist series</p> <p>2x block</p> <p>BCI® joist blocking holes cut for ventilation</p> <p>4'0" horiz.</p> <p>2'6" horiz.</p>	<p><b>R05</b></p> <p>Simpson Strong-Tie or MiTek LSTA24 strap, nail per governing building code</p> <p>BCI® blocking holes cut for ventilation</p> <p>Blocking on both sides of ridge may be required for shear transfer per design professional of record.</p> <p>Double-bevel wood plate</p> <p>Versa-Lam LVL support beam</p>	<p><b>R06</b></p> <p>Simpson Strong-Tie or MiTek LSTA24 strap where slope exceeds 7:12 (straps may be required for lower slopes in high-wind areas). Nail per building code.</p> <p>Versa-Lam LVL support beam</p> <p>Simpson Strong-Tie LSSUI or MiTek TMU hanger</p> <p>Beveled web stiffener on each side</p>
<p><b>R07</b></p> <p>Backer block (minimum 12" wide). Nail with ten 10d nails.</p> <p>Joist hanger</p> <p>Filler block: Nail with ten 10d nails.</p> <p>A backer block is required where the top flange hanger load exceeds 250 lbs. All face mount hangers require backer blocks on both sides of the supporting joist's web. For top flange hangers install tight to top flange. For face mount hangers, install tight to the bottom flange.</p>	<p><b>R11</b></p> <p>Double joist may be required when L exceeds rafter spacing.</p> <p>Blocking as required</p> <p>Nail outrigger through BCI® joist web</p> <p>2" x _ outrigger notched around BCI® joist top flange. Outrigger spacing no greater than 24" o.c.</p> <p>End wall</p>	<p><b>DN05</b></p> <p>DO NOT bevel-cut joist beyond the inside face of wall, except for specific conditions as shown in detail F14 on page 6. Also see page 13.</p>

### Lateral Support

- BCI® joists must be laterally supported at the ends (including supports adjacent to overhangs) with hangers, rim board, or blocking (Versa-Lam LVL®, Boise Cascade® Rimboard, or BCI® joist). Metal cross bracing or other x-bracing provides adequate lateral support for BCI® joists. Consult governing building code for roof diaphragm connection provisions.

### Minimum Bearing Length For BCI® Joists

- Minimum end bearing: 1 1/2" for all BCI® joists. 3 1/2" required at cantilever and intermediate supports.
- Longer bearing lengths allow higher reaction values. Refer to the building code evaluation report or the BC Calc® software.

### Nailing Requirements

- BCI® rim joist, rim board or closure panel to BCI® joist:**
  - Rims or closure panel:** Two nails, one each in the top and bottom flange; Up to 1 1/2" thick rim, use 8d x 2 1/2" nails; for 1 3/4" thick rim, use 10d box x 3" nails.
  - BCI® 5000 rim joist:** Two 10d box nails, one each in the top and bottom flange.
  - BCI® 6000/60 rim joist:** Two 16d box nails, one each in the top and bottom flange.
  - BCI® 6500/90 rim joist:** Toe-nail top flange to rim joist with Two 10d box nails, one each side of flange.
- BCI® rim joist, rim board or BCI® blocking panel to support:**
  - Min. 8d nails at 6" o.c. per IRC®.
  - Connection per design professional of record's specification for shear transfer.

### BCI® joist to support:

- Two 8d nails, one on each side of the web, placed 1 1/2" minimum from the end of the BCI® joist to limit splitting.

### Sheathing to BCI® joist:

- Prescriptive residential roof sheathing nailing requires 8d common nails at 6" o.c. on edges and at 12" o.c. in the field (IRC® Table R602.3(1)).
- See closest allowable nail spacing limits on page 24 for floor diaphragm nailing specified at closer spacing than IRC®.
- For full lateral stability, maximum nail spacing for bracing is 18" for BCI® 4500s and 5000s, and 24" for larger BCI® joist series.
- 14 gauge staples may be substituted for 8d nails if the staples penetrate at least 1" into the joist.
- Wood screws may be acceptable, contact local building official and/or Boise Cascade EWP Engineering for more information.

### Web Stiffeners

- See Web Stiffener Requirements on page 9.

### Maximum Slope

- Unless otherwise noted, all roof details are valid for slopes of 12:12 or less.

### Ventilation

- All 1 1/2", prepunched knock-out holes spaced at 12" o.c. along the BCI® joist may be knocked out and used for cross ventilation. When designing ventilation, using deeper joists than what is structurally required may be an advantage. Consult local building officials and/or ventilation specialists for specific requirements.

### Birdsmouth Cuts

- BCI® joists may be birdsmouth cut only at the low end support.
- BCI® joists with birdsmouth cuts may cantilever up to 2'-6" past the low end support.
- The bottom flange must sit fully on the support and may not overhang the inside face of the support.
- Birdsmouth cuts are NOT allowed at high end or intermediate supports.

### Backer and Filler Block Dimensions

Series	Backer Block Thickness	Filler Block Thickness
4500s	5/8" or 3/4" wood panels	Two 5/8" wood panels or 2 x _
5000s	3/4" or 7/8" wood panels	Two 3/4" wood panels or 2 x _
6000s	1 1/8" or two 1/2" wood panels	2 x _ + 7/16" or 1/2" wood panel
6500s	1 1/8" or two 5/8" wood panels	2 x _ + 5/8" or 3/4" wood panel
60s	1 1/8" or two 1/2" wood panels	2 x _ + 7/16" or 1/2" wood panel
90s	2 x _ lumber	Double 2 x _ lumber

- Cut backer and filler blocks to a maximum depth equal to the web depth minus 1/4" to avoid a forced fit.

# Roof Span Tables

Maximum clear span in feet and inches, based on horizontal spans.

## 115% and 125% Load Duration

Condition			BCI® 4500s 1.8 Joist												BCI® 5000s 1.8 Joist									
			9½"			11⅞"			14"			16"			9½"			11⅞"			14"			
O.C. Spacing and Load Duration	Live Load (psf)	Dead Load (psf)	4:12 or Less	4:12 to 8:12	8:12 to 12:12	4:12 or Less	4:12 to 8:12	8:12 to 12:12	4:12 or Less	4:12 to 8:12	8:12 to 12:12	4:12 or Less	4:12 to 8:12	8:12 to 12:12	4:12 or Less	4:12 to 8:12	8:12 to 12:12	4:12 or Less	4:12 to 8:12	8:12 to 12:12	4:12 or Less	4:12 to 8:12	8:12 to 12:12	
12" o.c.	Non-Snow 125%	20	10	23'-10"	22'-6"	20'-10"	28'-5"	26'-9"	24'-10"	32'-3"	30'-5"	28'-3"	35'-9"	33'-8"	31'-3"	24'-10"	23'-5"	21'-9"	29'-7"	27'-11"	25'-11"	33'-8"	31'-9"	29'-5"
		20	15	22'-7"	21'-3"	19'-7"	26'-11"	25'-3"	23'-4"	30'-7"	28'-9"	26'-6"	33'-6"	31'-10"	29'-4"	23'-6"	22'-1"	20'-5"	28'-0"	26'-4"	24'-4"	31'-10"	29'-11"	27'-7"
		20	20	21'-7"	20'-2"	18'-7"	25'-8"	24'-0"	22'-1"	29'-2"	27'-4"	25'-1"	31'-4"	30'-3"	27'-10"	22'-5"	21'-0"	19'-4"	26'-9"	25'-0"	23'-0"	30'-5"	28'-5"	26'-2"
	Snow 115%	25	10	22'-8"	21'-5"	19'-11"	26'-11"	25'-6"	23'-8"	30'-2"	29'-0"	26'-11"	32'-3"	31'-7"	29'-10"	23'-7"	22'-4"	20'-9"	28'-1"	26'-7"	24'-9"	31'-11"	30'-2"	28'-1"
		25	15	21'-7"	20'-4"	18'-10"	25'-9"	24'-2"	22'-5"	28'-2"	27'-5"	25'-6"	30'-1"	29'-4"	28'-3"	22'-6"	21'-2"	19'-7"	26'-10"	25'-3"	23'-4"	30'-3"	28'-8"	26'-7"
		30	10	21'-8"	20'-6"	19'-1"	25'-9"	24'-5"	22'-9"	28'-3"	27'-9"	25'-11"	30'-2"	29'-8"	28'-8"	22'-7"	21'-4"	19'-11"	26'-10"	25'-5"	23'-9"	30'-4"	28'-11"	27'-0"
		30	15	20'-9"	19'-7"	18'-2"	24'-5"	23'-4"	21'-8"	26'-7"	25'-11"	24'-7"	28'-5"	27'-9"	26'-10"	21'-7"	20'-5"	18'-11"	25'-9"	24'-4"	22'-7"	28'-6"	27'-8"	25'-8"
		40	10	19'-8"	18'-11"	17'-10"	23'-2"	22'-6"	21'-3"	25'-3"	24'-11"	24'-2"	27'-0"	26'-8"	26'-1"	20'-6"	19'-8"	18'-7"	24'-5"	23'-5"	22'-2"	27'-2"	26'-8"	25'-2"
		40	15	19'-5"	18'-4"	17'-1"	22'-1"	21'-8"	20'-4"	24'-1"	23'-7"	22'-11"	25'-8"	25'-2"	24'-6"	20'-2"	19'-1"	17'-10"	23'-8"	22'-9"	21'-3"	25'-10"	25'-4"	24'-1"
		50	10	18'-3"	17'-6"	16'-7"	21'-2"	20'-10"	19'-9"	23'-1"	22'-10"	22'-5"	24'-8"	24'-4"	24'-0"	19'-0"	18'-3"	17'-3"	22'-8"	21'-9"	20'-7"	24'-10"	24'-6"	23'-5"
50	15	17'-11"	17'-4"	16'-3"	20'-4"	20'-0"	19'-4"	22'-2"	21'-9"	21'-3"	23'-8"	23'-3"	22'-9"	19'-0"	18'-1"	16'-11"	21'-10"	21'-5"	20'-2"	23'-9"	23'-4"	22'-10"		
16" o.c.	Non-Snow 125%	20	10	21'-7"	20'-5"	18'-11"	25'-9"	24'-3"	22'-6"	29'-3"	27'-7"	25'-7"	31'-5"	30'-7"	28'-4"	22'-6"	21'-3"	19'-8"	26'-10"	25'-4"	23'-6"	30'-6"	28'-9"	26'-8"
		20	15	20'-6"	19'-3"	17'-9"	24'-4"	22'-11"	21'-1"	27'-2"	26'-0"	24'-0"	29'-0"	28'-2"	26'-7"	21'-4"	20'-0"	18'-6"	25'-5"	23'-10"	22'-0"	28'-11"	27'-1"	25'-0"
		20	20	19'-6"	18'-3"	16'-10"	23'-3"	21'-9"	20'-0"	25'-4"	24'-5"	22'-9"	27'-1"	26'-2"	24'-11"	20'-4"	19'-0"	17'-6"	24'-3"	22'-8"	20'-10"	27'-2"	25'-10"	23'-9"
	Snow 115%	25	10	20'-6"	19'-5"	18'-1"	24'-0"	23'-1"	21'-6"	26'-1"	25'-7"	24'-5"	27'-11"	27'-4"	26'-7"	21'-4"	20'-2"	18'-10"	25'-6"	24'-1"	22'-5"	28'-1"	27'-4"	25'-6"
		25	15	19'-7"	18'-5"	17'-1"	22'-4"	21'-9"	20'-4"	24'-4"	23'-9"	22'-11"	26'-0"	25'-4"	24'-5"	20'-5"	19'-2"	17'-9"	24'-0"	22'-10"	21'-2"	26'-2"	25'-6"	24'-1"
		30	10	19'-7"	18'-7"	17'-4"	22'-5"	22'-0"	20'-7"	24'-5"	24'-0"	23'-5"	26'-1"	25'-8"	25'-0"	20'-5"	19'-4"	18'-1"	24'-1"	23'-1"	21'-6"	26'-3"	25'-9"	24'-5"
		30	15	18'-7"	17'-9"	16'-6"	21'-1"	20'-7"	19'-7"	23'-0"	22'-5"	21'-9"	24'-7"	24'-0"	23'-3"	19'-7"	18'-6"	17'-2"	22'-8"	22'-0"	20'-5"	24'-8"	24'-1"	23'-3"
		40	10	17'-8"	17'-1"	16'-2"	20'-1"	19'-9"	19'-3"	21'-10"	21'-7"	21'-1"	23'-4"	23'-0"	22'-7"	18'-7"	17'-10"	16'-10"	21'-7"	21'-3"	20'-1"	23'-6"	23'-2"	22'-8"
		40	15	16'-10"	16'-6"	15'-6"	19'-1"	18'-8"	18'-2"	20'-10"	20'-5"	19'-10"	22'-3"	21'-10"	21'-3"	18'-1"	17'-4"	16'-1"	20'-6"	20'-1"	19'-3"	22'-4"	21'-11"	21'-4"
		50	10	16'-2"	15'-10"	15'-0"	18'-4"	18'-1"	17'-9"	19'-11"	19'-9"	19'-5"	21'-4"	21'-1"	20'-9"	17'-2"	16'-6"	15'-8"	19'-8"	19'-5"	18'-8"	21'-5"	21'-2"	20'-10"
50	15	15'-6"	15'-3"	14'-8"	17'-7"	17'-3"	16'-10"	19'-2"	18'-10"	18'-5"	20'-5"	20'-1"	19'-8"	16'-8"	16'-4"	15'-4"	18'-10"	18'-6"	18'-1"	20'-7"	20'-2"	19'-9"		
19.2" o.c.	Non-Snow 125%	20	10	20'-4"	19'-2"	17'-9"	24'-2"	22'-10"	21'-2"	26'-10"	25'-11"	24'-1"	28'-8"	28'-0"	26'-8"	21'-2"	19'-11"	18'-6"	25'-2"	23'-9"	22'-1"	28'-8"	27'-0"	25'-1"
		20	15	19'-3"	18'-1"	16'-8"	22'-9"	21'-6"	19'-10"	24'-9"	24'-0"	22'-7"	26'-5"	25'-8"	24'-8"	20'-0"	18'-10"	17'-4"	23'-10"	22'-5"	20'-8"	26'-7"	25'-6"	23'-6"
		20	20	18'-4"	17'-2"	15'-9"	21'-2"	20'-5"	18'-9"	23'-1"	22'-4"	21'-3"	24'-8"	23'-10"	22'-9"	19'-1"	17'-10"	16'-5"	22'-9"	21'-4"	19'-7"	24'-10"	23'-11"	22'-3"
	Snow 115%	25	10	19'-3"	18'-3"	17'-0"	21'-10"	21'-5"	20'-2"	23'-10"	23'-4"	22'-8"	25'-6"	24'-11"	24'-3"	20'-1"	19'-0"	17'-8"	23'-6"	22'-7"	21'-1"	25'-7"	25'-1"	23'-11"
		25	15	18'-0"	17'-4"	16'-0"	20'-5"	19'-10"	19'-1"	22'-3"	21'-8"	20'-10"	23'-9"	23'-1"	22'-4"	19'-2"	18'-0"	16'-8"	21'-11"	21'-4"	19'-11"	23'-10"	23'-3"	22'-5"
		30	10	18'-0"	17'-5"	16'-3"	20'-5"	20'-1"	19'-5"	22'-3"	21'-11"	21'-4"	23'-10"	23'-5"	22'-10"	19'-2"	18'-2"	16'-11"	22'-0"	21'-7"	20'-2"	23'-11"	23'-6"	22'-11"
		30	15	16'-11"	16'-7"	15'-6"	19'-3"	18'-9"	18'-2"	20'-11"	20'-5"	19'-10"	22'-5"	21'-10"	21'-2"	18'-3"	17'-4"	16'-1"	20'-8"	20'-2"	19'-2"	22'-6"	22'-0"	21'-3"
		40	10	16'-2"	15'-11"	15'-2"	18'-3"	18'-0"	17'-8"	19'-11"	19'-8"	19'-3"	21'-4"	21'-0"	20'-7"	17'-4"	16'-9"	15'-10"	19'-8"	19'-4"	18'-10"	21'-5"	21'-1"	20'-8"
		40	15	15'-4"	15'-0"	14'-6"	17'-5"	17'-1"	16'-7"	18'-11"	18'-7"	18'-1"	20'-3"	19'-10"	19'-4"	16'-6"	16'-2"	15'-2"	18'-8"	18'-4"	17'-10"	20'-4"	20'-0"	19'-5"
		50	10	14'-9"	14'-6"	14'-1"	16'-8"	16'-6"	16'-2"	18'-2"	18'-0"	17'-8"	19'-5"	19'-3"	18'-11"	15'-10"	15'-6"	14'-8"	17'-11"	17'-9"	17'-5"	19'-7"	19'-4"	19'-0"
50	15	14'-1"	13'-10"	13'-7"	16'-0"	15'-9"	15'-4"	17'-5"	17'-2"	16'-9"	18'-8"	18'-4"	17'-11"	15'-2"	14'-11"	14'-4"	17'-2"	16'-11"	16'-6"	18'-9"	18'-5"	18'-0"		
24" o.c.	Non-Snow 125%	20	10	18'-10"	17'-9"	16'-6"	22'-0"	21'-1"	19'-7"	24'-0"	23'-5"	22'-4"	25'-7"	25'-0"	24'-3"	19'-7"	18'-6"	17'-2"	23'-4"	22'-0"	20'-5"	25'-9"	25'-0"	23'-3"
		20	15	17'-10"	16'-9"	15'-5"	20'-3"	19'-8"	18'-4"	22'-1"	21'-5"	20'-7"	23'-8"	22'-11"	22'-0"	18'-6"	17'-5"	16'-1"	21'-10"	20'-9"	19'-2"	23'-9"	23'-1"	21'-9"
		20	20	16'-8"	15'-11"	14'-7"	18'-11"	18'-3"	17'-5"	20'-8"	19'-11"	19'-0"	22'-1"	21'-3"	20'-4"	17'-8"	16'-7"	15'-3"	20'-4"	19'-8"	18'-2"	22'-2"	21'-5"	20'-5"
	Snow 115%	25	10	17'-3"	16'-10"	15'-9"	19'-6"	19'-2"	18'-7"	21'-3"	20'-10"	20'-3"	22'-9"	22'-3"	21'-8"	18'-6"	17'-7"	16'-4"	21'-0"	20'-7"	19'-6"	22'-10"	22'-5"	21'-9"
		25	15	16'-1"	15'-7"	14'-10"	18'-2"	17'-9"	17'-1"	19'-10"	19'-4"	18'-8"	21'-3"	20'-8"	19'-11"	17'-3"	16'-8"	15'-5"	19'-7"	19'-1"	18'-4"	21'-4"	20'-9"	20'-6"
		30	10	16'-1"	15'-10"	15'-1"	18'-3"	17'-11"	17'-6"	19'-11"	19'-7"	19'-1"	21'-3"	20'-11"	20'-5"	17'-4"	16'-10"	15'-8"	19'-7"	19'-3"	18'-9"	21'-5"	21'-0"	20'-6"
		30	15	15'-2"	14'-9"	14'-4"	17'-2"	16'-9"	16'-3"	18'-9"	18'-3"	17'-8"	20'-0"	19'-6"	18'-11"	16'-3"	15'-11"	14'-11"	18'-5"	18'-0"	17'-5"	20'-1"	19'-8"	19'-0"
		40	10	14'-5"	14'-2"	13'-11"	16'-4"	16'-1"	15'-9"	17'-10"	17'-7"	17'-2"	19'-0"	18'-9"	18'-5"	15'-6"	15'-3"	14'-7"	17'-7"	17'-4"	16'-11"	19'-2"	18'-10"	18'-6"
		40	15	13'-8"	13'-5"	13'-1"	15'-6"	15'-3"	14'-10"	16'-11"	16'-7"	16'-2"	18'-1"	17'-9"	17'-3"	14'-9"	14'-5"	14'-0"	16'-8"	16'-4"	15'-11"	18'-2"	17'-10"	17'-4"
		50	10	13'-2"	13'-0"	12'-9"	14'-11"	14'-9"	14'-6"	16'-3"	16'-1"	15'-9"	17'-4"	17'-2"	16'-10"	14'-2"	13'-11"	13'-7"	16'-0"	15'-10"	15'-7"	17'-5"	17'-2"	16'-7"
50	15	12'-7"	12'-4"	12'-1"	14'-3"	14'-0"	13'-9"	15'-7"	15'-4"	14'-11"	16'-6"	16'-0"	15'-3"	13'-6"	13'-4"	13'-0"	15'-4"	14'-11"	14'-3"	16'-2"	15'-8"	14'-11"		

**NOTES**

- ▶ Table values
  - are limited by shear, moment, total load deflection equal to L/180 and live load deflection equal to L/240. Check the local building code for other deflection limits that may apply.
  - represent the most restrictive of simple or multiple span applications. Analyze multiple span joists with the BC Calc® software if the length of any span is less than half the length of an adjacent span.
  - assume minimum bearing lengths without web stiffeners for joist depths of 16" and less.

- ▶ This table was designed to apply to a broad range of applications. It may be possible to exceed the limitations of this table by analyzing a specific application with the BC Calc® software.
- ▶ Slope roof joists at least ¼:12 to minimize ponding.
- ▶ Allowable spans and loads shall be adjusted and checked for wind load as required by local building code.

# Roof Span Tables

Maximum clear span in feet and inches, based on horizontal spans.

## 115% and 125% Load Duration

Condition			BCI® 6000s 1.8 Joist												
			9½"			11⅞"			14"			16"			
O.C. Spacing and Load Duration	Live Load (psf)	Dead Load (psf)	4:12 or Less	4:12 to 8:12	8:12 to 12:12	4:12 or Less	4:12 to 8:12	8:12 to 12:12	4:12 or Less	4:12 to 8:12	8:12 to 12:12	4:12 or Less	4:12 to 8:12	8:12 to 12:12	
12" o.c.	Non-Snow 125%	20	10	26'-0"	24'-6"	22'-9"	30'-11"	29'-2"	27'-0"	35'-2"	33'-2"	30'-9"	38'-10"	36'-7"	34'-0"
		20	15	24'-7"	23'-1"	21'-4"	29'-3"	27'-6"	25'-4"	33'-3"	31'-3"	28'-10"	36'-9"	34'-6"	31'-10"
		20	20	23'-6"	22'-0"	20'-2"	27'-11"	26'-1"	24'-0"	31'-9"	29'-9"	27'-4"	35'-1"	32'-10"	30'-2"
	Snow 115%	25	10	24'-8"	23'-4"	21'-8"	29'-4"	27'-9"	25'-10"	33'-4"	31'-6"	29'-4"	36'-10"	34'-10"	32'-5"
		25	15	23'-6"	22'-2"	20'-6"	28'-0"	26'-4"	24'-5"	31'-10"	29'-11"	27'-9"	34'-11"	33'-1"	30'-8"
		30	10	23'-7"	22'-4"	20'-10"	28'-0"	26'-7"	24'-9"	31'-11"	30'-2"	28'-2"	35'-1"	33'-5"	31'-2"
		30	15	22'-7"	21'-4"	19'-9"	26'-11"	25'-4"	23'-6"	30'-7"	28'-10"	26'-9"	33'-0"	31'-11"	29'-7"
		40	10	21'-5"	20'-7"	19'-5"	25'-6"	24'-6"	23'-1"	29'-0"	27'-10"	26'-3"	31'-4"	30'-9"	29'-0"
		40	15	21'-1"	20'-0"	18'-7"	25'-1"	23'-9"	22'-2"	27'-11"	27'-1"	25'-2"	29'-10"	29'-3"	27'-10"
		50	10	19'-10"	19'-1"	18'-1"	23'-7"	23'-8"	21'-6"	26'-9"	25'-9"	24'-6"	28'-8"	28'-3"	27'-1"
50	15	19'-10"	18'-11"	17'-8"	23'-7"	22'-6"	21'-0"	25'-8"	25'-3"	23'-11"	27'-5"	27'-0"	26'-5"		
16" o.c.	Non-Snow 125%	20	10	23'-6"	22'-2"	20'-7"	28'-0"	26'-5"	24'-6"	31'-10"	30'-0"	27'-10"	35'-2"	33'-2"	30'-10"
		20	15	22'-3"	20'-11"	19'-4"	26'-6"	24'-11"	23'-0"	30'-2"	28'-4"	26'-2"	33'-4"	31'-4"	28'-11"
		20	20	21'-3"	19'-11"	18'-4"	25'-3"	23'-8"	21'-9"	28'-9"	26'-11"	24'-9"	31'-5"	29'-9"	27'-5"
	Snow 115%	25	10	22'-4"	21'-1"	19'-8"	26'-7"	25'-1"	23'-5"	30'-3"	28'-7"	26'-7"	32'-5"	31'-7"	29'-5"
		25	15	21'-4"	20'-1"	18'-7"	25'-4"	23'-10"	22'-1"	28'-3"	27'-2"	25'-2"	30'-3"	29'-5"	27'-9"
		30	10	21'-4"	20'-3"	18'-10"	25'-5"	24'-1"	22'-5"	28'-4"	27'-4"	25'-6"	30'-4"	29'-9"	28'-3"
		30	15	20'-6"	19'-4"	17'-11"	24'-4"	23'-0"	21'-4"	26'-8"	26'-0"	24'-3"	28'-6"	27'-10"	26'-10"
		40	10	19'-5"	18'-7"	17'-7"	23'-1"	22'-2"	20'-11"	25'-5"	25'-0"	23'-10"	27'-2"	26'-9"	26'-2"
		40	15	19'-1"	18'-1"	16'-10"	22'-2"	21'-6"	20'-1"	24'-2"	23'-8"	22'-10"	25'-10"	25'-4"	24'-8"
		50	10	18'-0"	17'-3"	16'-4"	21'-3"	20'-6"	19'-6"	23'-2"	23'-2"	22'-11"	22'-2"	24'-9"	24'-6"
50	15	17'-11"	17'-1"	16'-0"	20'-4"	20'-0"	19'-0"	22'-2"	21'-10"	21'-4"	23'-9"	23'-4"	22'-10"		
19.2" o.c.	Non-Snow 125%	20	10	22'-1"	20'-10"	19'-4"	26'-3"	24'-10"	23'-0"	29'-11"	28'-3"	26'-2"	33'-1"	31'-2"	28'-11"
		20	15	20'-11"	19'-8"	18'-2"	24'-11"	23'-5"	21'-7"	28'-4"	26'-7"	24'-7"	30'-8"	29'-5"	27'-2"
		20	20	19'-11"	18'-8"	17'-2"	23'-9"	22'-3"	20'-5"	26'-10"	25'-4"	23'-3"	28'-8"	27'-8"	25'-9"
	Snow 115%	25	10	21'-0"	19'-10"	18'-6"	24'-11"	23'-7"	22'-0"	27'-8"	26'-10"	25'-0"	29'-7"	28'-11"	27'-8"
		25	15	20'-0"	18'-10"	17'-5"	23'-8"	22'-5"	20'-9"	25'-9"	25'-1"	23'-7"	27'-7"	26'-10"	25'-11"
		30	10	20'-1"	19'-0"	17'-9"	23'-9"	22'-7"	21'-1"	25'-10"	25'-5"	24'-0"	27'-8"	27'-2"	26'-6"
		30	15	19'-3"	18'-2"	16'-10"	22'-4"	21'-7"	20'-0"	24'-4"	23'-9"	22'-10"	26'-0"	25'-5"	24'-7"
		40	10	18'-3"	17'-6"	16'-6"	21'-3"	20'-10"	19'-8"	23'-2"	22'-10"	22'-4"	24'-9"	24'-5"	23'-11"
		40	15	17'-10"	17'-0"	15'-10"	20'-2"	19'-10"	18'-10"	22'-0"	21'-7"	21'-0"	23'-6"	23'-1"	22'-6"
		50	10	16'-10"	16'-2"	15'-4"	19'-5"	19'-2"	18'-3"	21'-1"	20'-10"	20'-6"	22'-7"	22'-4"	21'-11"
50	15	16'-4"	16'-1"	15'-0"	18'-7"	18'-3"	17'-10"	20'-3"	19'-11"	19'-5"	21'-8"	21'-3"	20'-10"		
24" o.c.	Non-Snow 125%	20	10	20'-6"	19'-4"	17'-11"	24'-4"	23'-0"	21'-4"	27'-9"	26'-2"	24'-3"	29'-9"	28'-11"	26'-10"
		20	15	19'-4"	18'-2"	16'-10"	23'-0"	21'-8"	20'-0"	25'-8"	24'-8"	22'-9"	27'-5"	26'-7"	25'-2"
		20	20	18'-6"	17'-3"	15'-11"	22'-0"	20'-7"	18'-11"	23'-11"	23'-1"	21'-7"	25'-7"	24'-9"	23'-7"
	Snow 115%	25	10	19'-5"	18'-4"	17'-1"	22'-8"	21'-10"	20'-4"	24'-8"	24'-2"	23'-2"	26'-5"	25'-10"	25'-2"
		25	15	18'-6"	17'-5"	16'-2"	21'-2"	20'-7"	19'-3"	23'-0"	22'-5"	21'-8"	24'-8"	24'-0"	23'-2"
		30	10	18'-7"	17'-7"	16'-5"	21'-2"	20'-10"	19'-6"	23'-1"	22'-8"	22'-2"	24'-9"	24'-3"	23'-8"
		30	15	17'-7"	16'-9"	15'-7"	19'-11"	19'-6"	18'-7"	21'-9"	21'-3"	20'-6"	23'-3"	22'-8"	21'-11"
		40	10	16'-9"	16'-2"	15'-3"	19'-0"	18'-8"	18'-2"	20'-8"	20'-4"	20'-0"	22'-1"	21'-9"	21'-4"
		40	15	15'-11"	15'-7"	14'-8"	18'-0"	17'-8"	17'-2"	19'-8"	19'-3"	18'-9"	21'-0"	20'-7"	19'-8"
		50	10	15'-3"	14'-11"	14'-3"	17'-4"	17'-1"	16'-10"	18'-10"	18'-8"	18'-4"	19'-10"	19'-5"	18'-9"
50	15	14'-7"	14'-4"	13'-11"	16'-7"	16'-4"	15'-11"	17'-11"	17'-4"	16'-6"	18'-3"	17'-8"	16'-10"		

### NOTES

- ▶ Table values
  - are limited by shear, moment, total load deflection equal to L/180 and live load deflection equal to L/240. Check the local building code for other deflection limits that may apply.
  - represent the most restrictive of simple or multiple span applications. Analyze multiple span joists with the BC Calc® software if the length of any span is less than half the length of an adjacent span.
  - assume minimum bearing lengths without web stiffeners for joist depths of 16" and less.
- ▶ This table was designed to apply to a broad range of applications. It may be possible to exceed the limitations of this table by analyzing a specific application with the BC Calc® software.
- ▶ Slope roof joists at least ¼:12 to minimize ponding.
- ▶ Allowable spans and loads shall be adjusted and checked for wind load as required by local building code.

# Roof Span Tables

Maximum clear span in feet and inches, based on horizontal spans.

115% and 125% Load Duration															
Condition			BCI® 6500s 1.8 Joist												
			9½"			11⅞"			14"			16"			
O.C. Spacing and Load Duration	Live Load (psf)	Dead Load (psf)	4:12 or Less	4:12 to 8:12	8:12 to 12:12	4:12 or Less	4:12 to 8:12	8:12 to 12:12	4:12 or Less	4:12 to 8:12	8:12 to 12:12	4:12 or Less	4:12 to 8:12	8:12 to 12:12	
12" o.c.	Non-Snow 125%	20	10	26'-10"	25'-3"	23'-6"	31'-10"	30'-0"	27'-10"	36'-2"	34'-1"	31'-8"	40'-0"	37'-8"	35'-0"
		20	15	25'-5"	23'-10"	22'-0"	30'-2"	28'-4"	26'-1"	34'-3"	32'-2"	29'-8"	37'-10"	35'-7"	32'-10"
		20	20	24'-3"	22'-8"	20'-10"	28'-9"	26'-11"	24'-9"	32'-8"	30'-7"	28'-2"	36'-1"	33'-10"	31'-1"
	Snow 115%	25	10	25'-5"	24'-1"	22'-5"	30'-3"	28'-7"	26'-7"	34'-4"	32'-6"	30'-3"	37'-11"	35'-10"	33'-5"
		25	15	24'-3"	22'-10"	21'-2"	28'-10"	27'-2"	25'-1"	32'-9"	30'-10"	28'-7"	36'-2"	34'-1"	31'-7"
		30	10	24'-4"	23'-0"	21'-6"	28'-11"	27'-4"	25'-6"	32'-10"	31'-1"	29'-0"	36'-3"	34'-4"	32'-1"
		30	15	23'-4"	22'-0"	20'-5"	27'-8"	26'-2"	24'-3"	31'-6"	29'-9"	27'-7"	34'-8"	32'-10"	30'-6"
		40	10	22'-2"	21'-3"	20'-0"	26'-4"	25'-3"	23'-10"	29'-11"	28'-8"	27'-1"	33'-0"	31'-8"	29'-11"
		40	15	21'-9"	20'-7"	19'-3"	25'-11"	24'-6"	22'-10"	29'-5"	27'-10"	25'-11"	31'-5"	30'-9"	28'-8"
		50	10	20'-6"	19'-8"	18'-8"	24'-4"	23'-4"	22'-2"	27'-8"	26'-7"	25'-2"	30'-2"	29'-4"	27'-10"
50	15	20'-6"	19'-6"	18'-3"	24'-4"	23'-2"	21'-8"	27'-0"	26'-4"	24'-8"	28'-11"	28'-5"	27'-3"		
16" o.c.	Non-Snow 125%	20	10	24'-4"	22'-11"	21'-3"	28'-10"	27'-2"	25'-3"	32'-10"	30'-11"	28'-8"	36'-3"	34'-2"	31'-9"
		20	15	23'-0"	21'-7"	19'-11"	27'-4"	25'-8"	23'-8"	31'-1"	29'-2"	26'-11"	34'-4"	32'-3"	29'-9"
		20	20	21'-11"	20'-6"	18'-11"	26'-1"	24'-5"	22'-5"	29'-8"	27'-9"	25'-6"	32'-9"	30'-8"	28'-2"
	Snow 115%	25	10	23'-1"	21'-10"	20'-4"	27'-5"	25'-11"	24'-1"	31'-2"	29'-5"	27'-5"	34'-1"	32'-6"	30'-3"
		25	15	22'-0"	20'-8"	19'-2"	26'-1"	24'-7"	22'-9"	29'-8"	27'-11"	25'-11"	31'-10"	30'-11"	28'-7"
		30	10	22'-0"	20'-10"	19'-6"	26'-2"	24'-9"	23'-1"	29'-9"	28'-2"	26'-4"	31'-11"	31'-2"	29'-1"
		30	15	21'-1"	19'-11"	18'-6"	25'-1"	23'-8"	22'-0"	28'-1"	26'-11"	25'-0"	30'-0"	29'-4"	27'-7"
		40	10	20'-0"	19'-3"	18'-2"	23'-10"	22'-10"	21'-7"	26'-9"	26'-0"	24'-6"	28'-7"	28'-2"	27'-1"
		40	15	19'-9"	18'-8"	17'-5"	23'-4"	22'-2"	20'-8"	25'-5"	24'-11"	23'-6"	27'-2"	26'-8"	25'-11"
		50	10	18'-6"	17'-9"	16'-11"	22'-1"	21'-2"	20'-1"	24'-5"	24'-1"	22'-10"	26'-1"	25'-9"	25'-3"
50	15	18'-6"	17'-8"	16'-6"	21'-5"	21'-0"	19'-8"	23'-5"	23'-0"	22'-4"	25'-0"	24'-7"	24'-0"		
19.2" o.c.	Non-Snow 125%	20	10	22'-10"	21'-6"	20'-0"	27'-1"	25'-7"	23'-9"	30'-10"	29'-1"	27'-0"	34'-0"	32'-1"	29'-10"
		20	15	21'-7"	20'-3"	18'-9"	25'-8"	24'-1"	22'-3"	29'-2"	27'-5"	25'-4"	32'-3"	30'-3"	27'-11"
		20	20	20'-7"	19'-3"	17'-9"	24'-6"	22'-11"	21'-1"	27'-10"	26'-1"	24'-0"	30'-2"	28'-9"	26'-6"
	Snow 115%	25	10	21'-8"	20'-6"	19'-1"	25'-9"	24'-4"	22'-8"	29'-1"	27'-8"	25'-9"	31'-1"	30'-6"	28'-5"
		25	15	20'-8"	19'-5"	18'-0"	24'-6"	23'-1"	21'-5"	27'-2"	26'-3"	24'-4"	29'-0"	28'-3"	26'-11"
		30	10	20'-8"	19'-7"	18'-3"	24'-7"	23'-3"	21'-9"	27'-3"	26'-6"	24'-8"	29'-1"	28'-7"	27'-4"
		30	15	19'-10"	18'-9"	17'-5"	23'-6"	22'-3"	20'-8"	25'-7"	25'-0"	23'-6"	27'-5"	26'-9"	25'-11"
		40	10	18'-10"	18'-1"	17'-1"	22'-4"	21'-5"	20'-3"	24'-4"	24'-0"	23'-0"	26'-1"	25'-8"	25'-2"
		40	15	18'-6"	17'-6"	16'-4"	21'-3"	20'-10"	19'-5"	23'-2"	22'-9"	22'-1"	24'-9"	24'-4"	23'-8"
		50	10	17'-5"	16'-8"	15'-10"	20'-5"	19'-10"	18'-10"	22'-3"	22'-0"	21'-5"	23'-9"	23'-6"	23'-1"
50	15	17'-3"	16'-7"	15'-6"	19'-7"	19'-3"	18'-5"	21'-4"	21'-0"	20'-6"	22'-10"	22'-2"	21'-2"		
24" o.c.	Non-Snow 125%	20	10	21'-1"	19'-11"	18'-6"	25'-1"	23'-8"	22'-0"	28'-6"	26'-11"	25'-0"	31'-4"	29'-9"	27'-7"
		20	15	20'-0"	18'-9"	17'-4"	23'-9"	22'-4"	20'-7"	27'-0"	25'-5"	23'-5"	28'-11"	28'-0"	25'-11"
		20	20	19'-1"	17'-10"	16'-5"	22'-8"	21'-3"	19'-6"	25'-3"	24'-2"	22'-2"	26'-11"	26'-0"	24'-6"
	Snow 115%	25	10	20'-0"	18'-11"	17'-8"	23'-10"	22'-6"	21'-0"	26'-0"	25'-6"	23'-10"	27'-10"	27'-3"	26'-4"
		25	15	19'-1"	18'-0"	16'-8"	22'-3"	21'-5"	19'-10"	24'-3"	23'-7"	22'-6"	25'-11"	25'-3"	24'-4"
		30	10	19'-2"	18'-2"	16'-11"	22'-4"	21'-7"	20'-1"	24'-4"	23'-11"	22'-11"	26'-0"	25'-7"	24'-11"
		30	15	18'-4"	17'-4"	16'-1"	21'-0"	20'-6"	19'-1"	22'-10"	22'-4"	21'-7"	24'-5"	23'-11"	23'-1"
		40	10	17'-5"	16'-8"	15'-9"	20'-0"	19'-8"	18'-9"	21'-9"	21'-5"	21'-0"	23'-3"	22'-11"	22'-3"
		40	15	16'-9"	16'-2"	15'-1"	19'-0"	18'-7"	18'-0"	20'-8"	20'-4"	19'-3"	21'-7"	20'-9"	19'-8"
		50	10	16'-1"	15'-5"	14'-8"	18'-3"	18'-0"	17'-5"	19'-6"	19'-0"	18'-5"	19'-10"	19'-5"	18'-9"
50	15	15'-5"	15'-2"	14'-4"	17'-3"	16'-8"	15'-11"	17'-11"	17'-4"	16'-6"	18'-3"	17'-8"	16'-10"		

**NOTES**

- ▶ Table values
  - are limited by shear, moment, total load deflection equal to L/180 and live load deflection equal to L/240. Check the local building code for other deflection limits that may apply.
  - represent the most restrictive of simple or multiple span applications. Analyze multiple span joists with the BC Calc® software if the length of any span is less than half the length of an adjacent span.
  - assume minimum bearing lengths without web stiffeners for joist depths of 16" and less.
- ▶ This table was designed to apply to a broad range of applications. It may be possible to exceed the limitations of this table by analyzing a specific application with the BC Calc® software.
- ▶ Slope roof joists at least ¼:12 to minimize ponding.
- ▶ Allowable spans and loads shall be adjusted and checked for wind load as required by local building code.

# Roof Span Tables

Maximum clear span in feet and inches, based on horizontal spans.

## 115% and 125% Load Duration

Condition			BCI® 60s 2.0 Joist									BCI® 90s 2.0 Joist									
			11 7/8"			14"			16"			11 7/8"			14"			16"			
O.C. Spacing and Load Duration	Live Load (psf)	Dead Load (psf)	4:12 or Less	4:12 to 8:12	8:12 to 12:12	4:12 or Less	4:12 to 8:12	8:12 to 12:12	4:12 or Less	4:12 to 8:12	8:12 to 12:12	4:12 or Less	4:12 to 8:12	8:12 to 12:12	4:12 or Less	4:12 to 8:2	8:12 to 12:12	4:12 or Less	4:12 to 8:12	8:12 to 12:12	
12" o.c.	Non-Snow 125%	20	10	34'-1"	32'-2"	29'-10"	38'-9"	36'-7"	33'-11"	42'-11"	40'-6"	37'-7"	39'-0"	36'-10"	34'-2"	44'-3"	41'-9"	38'-9"	49'-0"	46'-3"	42'-11"
		20	15	32'-4"	30'-4"	28'-0"	36'-9"	34'-6"	31'-10"	40'-8"	38'-3"	35'-3"	37'-0"	34'-9"	32'-1"	41'-11"	39'-4"	36'-4"	46'-5"	43'-7"	40'-3"
		20	20	30'-10"	28'-10"	26'-6"	35'-1"	32'-10"	30'-2"	38'-10"	36'-4"	33'-5"	35'-3"	33'-0"	30'-4"	39'-11"	37'-5"	34'-5"	44'-3"	41'-5"	38'-1"
	Snow 115%	25	10	32'-5"	30'-7"	28'-6"	36'-10"	34'-10"	32'-5"	40'-10"	38'-7"	35'-11"	37'-1"	35'-0"	32'-7"	42'-0"	39'-8"	36'-11"	46'-6"	44'-0"	40'-11"
		25	15	30'-11"	29'-1"	26'-11"	35'-2"	33'-1"	30'-7"	38'-11"	36'-8"	33'-11"	35'-4"	33'-3"	30'-10"	40'-1"	37'-9"	34'-11"	44'-4"	41'-9"	38'-8"
		30	10	31'-0"	29'-4"	27'-4"	35'-3"	33'-4"	31'-1"	39'-0"	36'-11"	34'-5"	35'-5"	33'-7"	31'-4"	40'-2"	38'-0"	35'-6"	44'-6"	42'-1"	39'-4"
		30	15	29'-8"	28'-0"	26'-0"	33'-9"	31'-10"	29'-7"	37'-5"	35'-3"	32'-9"	34'-0"	32'-1"	29'-9"	38'-6"	36'-4"	33'-9"	42'-8"	40'-3"	37'-4"
		40	10	28'-2"	27'-0"	25'-6"	32'-1"	30'-9"	29'-0"	35'-6"	34'-1"	32'-2"	32'-3"	30'-11"	29'-2"	36'-6"	35'-0"	33'-1"	40'-6"	38'-10"	36'-8"
		40	15	27'-9"	26'-3"	24'-6"	31'-7"	29'-10"	27'-10"	34'-11"	33'-1"	30'-10"	31'-9"	30'-0"	28'-0"	36'-0"	34'-0"	31'-9"	39'-10"	37'-9"	35'-2"
		50	10	26'-1"	25'-0"	23'-9"	29'-8"	28'-6"	27'-0"	32'-11"	31'-6"	29'-11"	29'-10"	28'-8"	27'-2"	33'-10"	32'-5"	30'-10"	37'-6"	35'-11"	34'-2"
50	15	26'-1"	24'-10"	23'-3"	29'-8"	28'-3"	26'-5"	32'-11"	31'-4"	29'-3"	29'-10"	28'-5"	26'-7"	33'-10"	32'-3"	30'-1"	37'-6"	35'-8"	33'-5"		
16" o.c.	Non-Snow 125%	20	10	30'-11"	29'-2"	27'-1"	35'-2"	33'-2"	30'-9"	38'-11"	36'-9"	34'-1"	35'-4"	33'-4"	31'-0"	40'-1"	37'-10"	35'-1"	44'-5"	41'-11"	38'-11"
		20	15	29'-3"	27'-6"	25'-5"	33'-4"	31'-3"	28'-10"	36'-11"	34'-8"	32'-0"	33'-6"	31'-6"	29'-1"	37'-11"	35'-8"	32'-11"	42'-0"	39'-6"	36'-6"
		20	20	27'-11"	26'-2"	24'-1"	31'-9"	29'-9"	27'-4"	35'-2"	32'-11"	30'-4"	31'-11"	29'-11"	27'-6"	36'-2"	33'-11"	31'-2"	40'-1"	37'-7"	34'-7"
	Snow 115%	25	10	29'-4"	27'-9"	25'-10"	33'-5"	31'-7"	29'-5"	37'-0"	34'-11"	32'-7"	33'-7"	31'-9"	29'-7"	38'-1"	36'-0"	33'-6"	42'-2"	39'-10"	37'-1"
		25	15	28'-0"	26'-4"	24'-5"	31'-10"	30'-0"	27'-9"	35'-3"	33'-2"	30'-9"	32'-0"	30'-2"	27'-11"	36'-3"	34'-2"	31'-8"	40'-2"	37'-10"	35'-1"
		30	10	28'-1"	26'-7"	24'-10"	31'-11"	30'-3"	28'-2"	35'-4"	33'-6"	31'-3"	32'-1"	30'-5"	28'-4"	36'-4"	34'-5"	32'-2"	40'-3"	38'-2"	35'-8"
		30	15	26'-11"	25'-5"	23'-7"	30'-7"	28'-10"	26'-10"	33'-11"	32'-0"	29'-8"	30'-9"	29'-0"	27'-0"	34'-10"	32'-11"	30'-7"	38'-7"	36'-5"	33'-10"
		40	10	25'-6"	24'-6"	23'-1"	29'-0"	27'-10"	26'-4"	32'-2"	30'-10"	29'-2"	29'-2"	28'-0"	26'-5"	33'-1"	31'-9"	30'-0"	36'-8"	35'-2"	33'-3"
		40	15	25'-1"	23'-9"	22'-2"	28'-7"	27'-1"	25'-3"	31'-8"	30'-0"	27'-11"	28'-9"	27'-2"	25'-4"	32'-7"	30'-10"	28'-9"	36'-1"	34'-2"	31'-10"
		50	10	23'-7"	22'-8"	21'-6"	26'-10"	25'-9"	24'-6"	29'-9"	28'-7"	27'-1"	27'-0"	25'-11"	24'-7"	30'-7"	29'-5"	27'-11"	33'-11"	32'-7"	30'-11"
50	15	23'-7"	22'-6"	21'-0"	26'-10"	25'-7"	23'-11"	28'-7"	27'-8"	26'-5"	27'-0"	25'-9"	24'-1"	30'-7"	29'-2"	27'-3"	33'-11"	32'-4"	30'-3"		
19.2" o.c.	Non-Snow 125%	20	10	29'-1"	27'-5"	25'-5"	33'-0"	31'-2"	28'-11"	36'-7"	34'-6"	32'-0"	33'-3"	31'-4"	29'-1"	37'-8"	35'-6"	33'-0"	41'-8"	39'-4"	36'-7"
		20	15	27'-6"	25'-10"	23'-10"	31'-3"	29'-5"	27'-1"	34'-8"	32'-7"	30'-1"	31'-5"	29'-7"	27'-3"	35'-8"	33'-6"	30'-11"	39'-6"	37'-1"	34'-3"
		20	20	26'-3"	24'-7"	22'-7"	29'-10"	27'-11"	25'-8"	33'-0"	30'-11"	28'-6"	30'-0"	28'-1"	25'-10"	34'-0"	31'-10"	29'-3"	37'-8"	35'-3"	32'-5"
	Snow 115%	25	10	27'-7"	26'-1"	24'-3"	31'-4"	29'-8"	27'-7"	34'-9"	32'-10"	30'-7"	31'-6"	29'-10"	27'-9"	35'-9"	33'-10"	31'-6"	39'-7"	37'-5"	34'-11"
		25	15	26'-3"	24'-9"	22'-11"	29'-11"	28'-2"	26'-1"	33'-1"	31'-2"	28'-11"	30'-1"	28'-4"	26'-3"	34'-1"	32'-1"	29'-9"	37'-9"	35'-7"	32'-11"
		30	10	26'-4"	25'-0"	23'-4"	30'-0"	28'-5"	26'-6"	33'-2"	31'-5"	29'-4"	30'-1"	28'-7"	26'-8"	34'-2"	32'-4"	30'-2"	37'-10"	35'-10"	33'-6"
		30	15	25'-3"	23'-10"	22'-2"	28'-9"	27'-1"	25'-2"	31'-10"	30'-0"	27'-11"	28'-10"	27'-3"	25'-4"	32'-9"	30'-11"	28'-8"	36'-3"	34'-3"	31'-10"
		40	10	24'-0"	23'-0"	21'-9"	27'-3"	26'-2"	24'-8"	30'-2"	29'-0"	27'-4"	27'-5"	26'-3"	24'-10"	31'-0"	29'-10"	28'-2"	34'-5"	33'-0"	31'-2"
		40	15	23'-7"	22'-4"	20'-10"	26'-10"	25'-5"	23'-8"	28'-1"	27'-0"	25'-7"	26'-11"	25'-6"	23'-10"	30'-7"	28'-11"	27'-0"	33'-10"	32'-1"	29'-11"
		50	10	22'-2"	21'-3"	20'-3"	25'-3"	24'-2"	23'-0"	25'-10"	25'-3"	24'-5"	25'-4"	24'-4"	23'-1"	28'-8"	27'-7"	26'-2"	31'-10"	30'-7"	29'-1"
50	15	22'-2"	21'-2"	19'-9"	23'-9"	23'-0"	21'-11"	23'-9"	23'-0"	21'-11"	25'-4"	24'-2"	22'-7"	28'-8"	27'-5"	25'-7"	29'-8"	28'-8"	27'-5"		
24" o.c.	Non-Snow 125%	20	10	26'-11"	25'-5"	23'-7"	30'-7"	28'-10"	26'-10"	33'-11"	32'-0"	29'-8"	30'-9"	29'-0"	27'-0"	34'-10"	32'-11"	30'-7"	38'-7"	36'-5"	33'-10"
		20	15	25'-6"	23'-11"	22'-1"	28'-11"	27'-2"	25'-2"	32'-1"	30'-2"	27'-10"	29'-1"	27'-4"	25'-3"	33'-0"	31'-0"	28'-8"	36'-7"	34'-4"	31'-9"
		20	20	24'-3"	22'-9"	20'-11"	27'-7"	25'-10"	23'-10"	30'-7"	28'-8"	26'-4"	27'-9"	26'-0"	23'-11"	31'-5"	29'-6"	27'-1"	34'-10"	32'-8"	30'-1"
	Snow 115%	25	10	25'-6"	24'-2"	22'-6"	29'-0"	27'-6"	25'-7"	32'-2"	30'-5"	28'-4"	29'-2"	27'-7"	25'-9"	33'-1"	31'-4"	29'-2"	36'-8"	34'-8"	32'-4"
		25	15	24'-4"	22'-11"	21'-3"	27'-8"	26'-1"	24'-2"	30'-8"	28'-11"	26'-9"	27'-10"	26'-3"	24'-4"	31'-6"	29'-9"	27'-6"	34'-11"	32'-11"	30'-6"
		30	10	24'-5"	23'-1"	21'-7"	27'-9"	26'-3"	24'-6"	30'-9"	29'-1"	27'-2"	27'-11"	26'-5"	24'-8"	31'-7"	29'-11"	28'-0"	35'-0"	33'-2"	31'-0"
		30	15	23'-4"	22'-1"	20'-6"	26'-7"	25'-1"	23'-4"	27'-4"	26'-1"	24'-5"	26'-9"	25'-3"	23'-5"	30'-3"	28'-7"	26'-7"	33'-7"	31'-8"	29'-5"
		40	10	22'-2"	21'-3"	20'-1"	24'-9"	24'-1"	22'-10"	24'-9"	24'-1"	23'-1"	25'-4"	24'-4"	23'-0"	28'-8"	27'-7"	26'-1"	30'-11"	30'-0"	28'-10"
		40	15	21'-10"	20'-8"	19'-3"	22'-5"	21'-6"	20'-5"	22'-5"	21'-6"	20'-5"	24'-11"	23'-7"	22'-0"	27'-9"	26'-8"	25'-0"	28'-0"	26'-11"	25'-6"
		50	10	20'-6"	19'-8"	18'-9"	20'-8"	20'-2"	19'-6"	20'-8"	20'-2"	19'-6"	23'-5"	22'-6"	21'-5"	25'-7"	24'-11"	24'-1"	25'-9"	25'-2"	24'-4"
50	15	19'-0"	18'-4"	17'-6"	19'-0"	18'-4"	17'-6"	19'-0"	18'-4"	17'-6"	23'-4"	22'-4"	20'-11"	23'-6"	22'-9"	21'-8"	23'-8"	22'-11"	21'-10"		

### NOTES

#### ► Table values

- are limited by shear, moment, total load deflection equal to L/180 and live load deflection equal to L/240. Check the local building code for other deflection limits that may apply.
- represent the most restrictive of simple or multiple span applications. Analyze multiple span joists with the BC Calc® software if the length of any span is less than half the length of an adjacent span.
- assume minimum bearing lengths without web stiffeners for joist depths of 16" and less.

► This table was designed to apply to a broad range of applications. It may be possible to exceed the limitations of this table by analyzing a specific application with the BC Calc® software.

► Slope roof joists at least ¼:12 to minimize ponding.

► Allowable spans and loads shall be adjusted and checked for wind load as required by local building code.

# Roof Load Tables

## Allowable Uniform Roof Load in pounds per lineal foot (PLF)

### 115% and 125% Load Duration

Use of these tables should be limited to roof slopes of 3½:12 or less. For steeper slopes, see pages 15–18.

Span Length	BCI® 4500s 1.8 Joist											
	9½"			11⅞"			14"			16"		
	Total Load		Deflection	Total Load		Deflection	Total Load		Deflection	Total Load		Deflection
	Snow (115%)	Non-Snow (125%)	L/240	Snow (115%)	Non-Snow (125%)	L/240	Snow (115%)	Non-Snow (125%)	L/240	Snow (115%)	Non-Snow (125%)	L/240
6	315	343	–	338	367	–	353	383	–	356	387	–
7	270	294	–	289	315	–	302	329	–	305	332	–
8	236	257	–	253	275	–	264	287	–	267	290	–
9	210	228	–	225	245	–	235	255	–	237	258	–
10	189	205	–	202	220	–	211	230	–	214	232	–
11	172	187	–	184	200	–	192	209	–	194	211	–
12	147	160	–	169	183	–	176	191	–	178	193	–
13	125	136	–	156	169	–	162	177	–	164	179	–
14	108	118	107	139	151	–	151	164	–	152	166	–
15	94	102	88	121	131	–	141	153	–	142	155	–
16	83	90	73	106	115	–	126	137	–	133	145	–
17	73	80	61	94	102	–	111	121	–	125	136	–
18	65	67	51	84	91	–	99	108	–	113	123	–
19	58	58	44	75	82	73	89	97	–	102	111	–
20	49	49	38	68	74	63	80	87	–	92	100	–
21	43	43	33	61	67	54	73	79	–	83	90	–
22				56	61	47	66	72	–	76	82	–
23				51	54	42	61	66	–	69	75	–
24				47	48	37	56	60	54	64	69	–
25				43	43	32	51	56	48	59	64	–
26							47	51	42	54	59	–
27							44	48	38	50	54	–
28							41	44	34	47	51	46
29										43	47	41
30										40	44	37

#### NOTES

- ▶ Total Load values are limited by shear, moment, or deflection equal to L/180.
- ▶ Deflection values are limited by live load deflection equal to L/240. Check the local building code for other deflection limits that may apply.
- ▶ Both the Total Load and Deflection columns must be checked. Where a deflection value is not shown, the total load value will control.
- ▶ Table values assume minimum bearing lengths without web stiffeners for joist depths of 16" and less.
- ▶ Slope roof joists at least ¼:12 to minimize ponding.
- ▶ Table values apply to either simple or multiple span joists. Span is measured center-to-center of the minimum required bearing length. Analyze multiple span joists with the BC Calc® software if the length of any span is less than half the length of an adjacent span.
- ▶ This table was designed to apply to a broad range of applications. It may be possible to exceed the limitations of this table by analyzing a specific application with the BC Calc® software.
- ▶ Allowable spans and loads shall be adjusted and checked for wind load as required by local building code.

# Roof Load Tables

## Allowable Uniform Roof Load in pounds per lineal foot (PLF)

### 115% and 125% Load Duration

Use of these tables should be limited to roof slopes of 3½:12 or less. For steeper slopes, see pages 15–18.

Span Length	BCI® 5000s 1.8 Joist								
	9½"			11⅞"			14"		
	Total Load		Deflection	Total Load		Deflection	Total Load		Deflection
	Snow (115%)	Non-Snow (125%)	L/240	Snow (115%)	Non-Snow (125%)	L/240	Snow (115%)	Non-Snow (125%)	L/240
6	315	343	–	338	367	–	353	383	–
7	270	294	–	289	315	–	302	329	–
8	236	257	–	253	275	–	264	287	–
9	210	228	–	225	245	–	235	255	–
10	189	205	–	202	220	–	211	230	–
11	172	187	–	184	200	–	192	209	–
12	157	171	–	169	183	–	176	191	–
13	145	158	–	156	169	–	162	177	–
14	125	136	120	144	157	–	151	164	–
15	109	118	98	135	147	–	141	153	–
16	95	104	81	122	133	–	132	143	–
17	85	89	68	108	118	–	124	135	–
18	75	76	58	96	105	–	114	124	–
19	65	65	49	87	94	82	103	112	–
20	56	56	42	78	85	71	93	101	–
21	48	48	37	71	77	61	84	91	–
22	42	42	32	64	70	54	76	83	–
23				59	62	47	70	76	68
24				54	54	41	64	70	60
25				48	48	37	59	64	54
26				43	43	33	55	59	48
27							51	55	43
28							47	50	38

#### NOTES

- ▶ Total Load values are limited by shear, moment, or deflection equal to L/180.
- ▶ Deflection values are limited by live load deflection equal to L/240. Check the local building code for other deflection limits that may apply.
- ▶ Both the Total Load and Deflection columns must be checked. Where a deflection value is not shown, the total load value will control.
- ▶ Table values assume minimum bearing lengths without web stiffeners for joist depths of 16" and less.
- ▶ Slope roof joists at least ¼:12 to minimize ponding.

- ▶ Table values apply to either simple or multiple span joists. Span is measured center-to-center of the minimum required bearing length. Analyze multiple span joists with the BC Calc® software if the length of any span is less than half the length of an adjacent span.
- ▶ This table was designed to apply to a broad range of applications. It may be possible to exceed the limitations of this table by analyzing a specific application with the BC Calc® software.
- ▶ Allowable spans and loads shall be adjusted and checked for wind load as required by local building code.

# Roof Load Tables

## Allowable Uniform Roof Load in pounds per lineal foot (PLF)

### 115% and 125% Load Duration

Use of these tables should be limited to roof slopes of 3½:12 or less. For steeper slopes, see pages 15–18.

Span Length	BCI® 6000s 1.8 Joist											
	9½"			11⅞"			14"			16"		
	Total Load		Deflection	Total Load		Deflection	Total Load		Deflection	Total Load		Deflection
	Snow (115%)	Non-Snow (125%)	L/240	Snow (115%)	Non-Snow (125%)	L/240	Snow (115%)	Non-Snow (125%)	L/240	Snow (115%)	Non-Snow (125%)	L/240
6	360	392	–	375	408	–	390	424	–	398	432	–
7	309	336	–	322	350	–	334	364	–	341	371	–
8	270	294	–	281	306	–	293	318	–	298	324	–
9	240	261	–	250	272	–	260	283	–	265	288	–
10	216	235	–	225	245	–	234	254	–	238	259	–
11	196	213	–	204	222	–	213	231	–	217	236	–
12	180	196	–	187	204	–	195	212	–	199	216	–
13	166	180	–	173	188	–	180	196	–	183	199	–
14	145	158	135	161	175	–	167	182	–	170	185	–
15	126	137	111	150	163	–	156	169	–	159	173	–
16	111	121	92	140	153	–	146	159	–	149	162	–
17	98	101	78	126	137	–	137	149	–	140	152	–
18	86	86	66	112	122	108	130	141	–	132	144	–
19	74	74	56	101	110	92	120	130	–	125	136	–
20	63	63	48	91	99	80	108	117	–	119	129	–
21	55	55	42	83	90	69	98	107	–	112	122	–
22	48	48	36	75	79	60	89	97	88	102	111	–
23	42	42	32	69	70	53	82	89	78	93	101	–
24				61	61	47	75	81	68	86	93	–
25				54	54	42	69	75	61	79	86	–
26				49	49	37	64	69	54	73	79	–
27				43	43	33	59	63	48	67	73	65
28							55	57	44	63	68	58

#### NOTES

- ▶ Total Load values are limited by shear, moment, or deflection equal to L/180.
- ▶ Deflection values are limited by live load deflection equal to L/240. Check the local building code for other deflection limits that may apply.
- ▶ Both the Total Load and Deflection columns must be checked. Where a deflection value is not shown, the total load value will control.
- ▶ Table values assume minimum bearing lengths without web stiffeners for joist depths of 16" and less.
- ▶ Slope roof joists at least ¼:12 to minimize ponding.
- ▶ Table values apply to either simple or multiple span joists. Span is measured center-to-center of the minimum required bearing length. Analyze multiple span joists with the BC Calc® software if the length of any span is less than half the length of an adjacent span.
- ▶ This table was designed to apply to a broad range of applications. It may be possible to exceed the limitations of this table by analyzing a specific application with the BC Calc® software.
- ▶ Allowable spans and loads shall be adjusted and checked for wind load as required by local building code.

# Roof Load Tables

## Allowable Uniform Roof Load in pounds per lineal foot (PLF)

### 115% and 125% Load Duration

Use of these tables should be limited to roof slopes of 3½:12 or less. For steeper slopes, see pages 15–18.

Span Length	BCI® 6500s 1.8 Joist											
	9½"			11⅞"			14"			16"		
	Total Load		Deflection	Total Load		Deflection	Total Load		Deflection	Total Load		Deflection
	Snow (115%)	Non-Snow (125%)	L/240	Snow (115%)	Non-Snow (125%)	L/240	Snow (115%)	Non-Snow (125%)	L/240	Snow (115%)	Non-Snow (125%)	L/240
6	360	392	–	375	408	–	390	424	–	398	432	–
7	309	336	–	322	350	–	334	364	–	341	371	–
8	270	294	–	281	306	–	293	318	–	298	324	–
9	240	261	–	250	272	–	260	283	–	265	288	–
10	216	235	–	225	245	–	234	254	–	238	259	–
11	196	213	–	204	222	–	213	231	–	217	236	–
12	180	196	–	187	204	–	195	212	–	199	216	–
13	166	180	–	173	188	–	180	196	–	183	199	–
14	154	168	147	161	175	–	167	182	–	170	185	–
15	140	152	121	150	163	–	156	169	–	159	173	–
16	123	132	101	140	153	–	146	159	–	149	162	–
17	109	111	85	132	144	–	137	149	–	140	152	–
18	94	94	72	125	135	118	130	141	–	132	144	–
19	80	80	61	112	122	101	123	134	–	125	136	–
20	69	69	53	101	110	87	117	127	–	119	129	–
21	60	60	46	91	99	76	108	118	–	113	123	–
22	52	52	40	83	87	66	99	107	96	108	118	–
23	46	46	35	76	76	58	90	98	84	103	112	–
24	41	41	31	67	67	51	83	90	74	95	103	–
25				60	60	45	76	83	66	87	95	–
26				53	53	40	71	77	59	81	88	79
27				47	47	36	65	69	53	75	81	71
28				43	43	32	61	62	47	69	76	63
29							56	56	43	65	70	57
30							51	51	39	60	66	52
31							46	46	35	57	62	47
32							42	42	32	53	56	43
33										50	51	39
34										47	47	36
35										43	43	33

**NOTES**

- ▶ Total Load values are limited by shear, moment, or deflection equal to L/180.
- ▶ Deflection values are limited by live load deflection equal to L/240. Check the local building code for other deflection limits that may apply.
- ▶ Both the Total Load and Deflection columns must be checked. Where a deflection value is not shown, the total load value will control.
- ▶ Table values assume minimum bearing lengths without web stiffeners for joist depths of 16" and less.
- ▶ Slope roof joists at least ¼:12 to minimize ponding.

- ▶ Table values apply to either simple or multiple span joists. Span is measured center-to-center of the minimum required bearing length. Analyze multiple span joists with the BC Calc® software if the length of any span is less than half the length of an adjacent span.
- ▶ This table was designed to apply to a broad range of applications. It may be possible to exceed the limitations of this table by analyzing a specific application with the BC Calc® software.
- ▶ Allowable spans and loads shall be adjusted and checked for wind load as required by local building code.

# Roof Load Tables

## Allowable Uniform Roof Load in pounds per lineal foot (PLF)

### 115% and 125% Load Duration

Use of these tables should be limited to roof slopes of 3½:12 or less. For steeper slopes, see pages 15–18.

Span Length	BCI® 60s 2.0 Joist									BCI® 90s 2.0 Joist								
	11⅞"			14"			16"			11⅞"			14"			16"		
	Total Load		Deflection	Total Load		Deflection	Total Load		Deflection	Total Load		Deflection	Total Load		Deflection	Total Load		Deflection
	Snow (115%)	Non-Snow (125%)	L/240	Snow (115%)	Non-Snow (125%)	L/240	Snow (115%)	Non-Snow (125%)	L/240	Snow (115%)	Non-Snow (125%)	L/240	Snow (115%)	Non-Snow (125%)	L/240	Snow (115%)	Non-Snow (125%)	L/240
6	413	449	–	413	449	–	413	449	–	507	551	–	510	555	–	514	559	–
7	354	385	–	354	385	–	354	385	–	434	472	–	437	476	–	441	479	–
8	309	336	–	309	336	–	309	336	–	380	413	–	383	416	–	385	419	–
9	275	299	–	275	299	–	275	299	–	338	367	–	340	370	–	343	372	–
10	247	269	–	247	269	–	247	269	–	304	330	–	306	333	–	308	335	–
11	225	245	–	225	245	–	225	245	–	276	300	–	278	302	–	280	305	–
12	206	224	–	206	224	–	206	224	–	253	275	–	255	277	–	257	279	–
13	190	207	–	190	207	–	190	207	–	234	254	–	235	256	–	237	258	–
14	177	192	–	177	192	–	177	192	–	217	236	–	218	238	–	220	239	–
15	165	179	–	165	179	–	165	179	–	202	220	–	204	222	–	205	223	–
16	154	168	–	154	168	–	154	168	–	190	206	–	191	208	–	192	209	–
17	145	158	–	145	158	–	145	158	–	178	194	–	180	196	–	181	197	–
18	137	149	–	137	149	–	137	149	–	169	183	–	170	185	–	171	186	–
19	130	141	123	130	141	–	130	141	–	160	174	–	161	175	–	162	176	–
20	123	134	106	123	134	–	123	134	–	152	165	–	153	166	–	154	167	–
21	118	121	92	118	128	–	118	128	–	144	157	134	145	158	–	147	159	–
22	106	106	81	112	122	–	112	122	–	138	150	118	139	151	–	140	152	–
23	93	93	71	107	117	103	107	117	–	132	136	104	133	144	–	134	145	–
24	82	82	63	103	112	91	103	112	–	120	120	92	127	138	–	128	139	–
25	73	73	56	99	106	81	99	107	–	107	107	82	122	133	117	123	134	–
26	65	65	50	94	94	72	95	103	–	96	96	73	117	128	104	118	129	–
27	58	58	44	85	85	65	91	99	87	86	86	65	113	123	94	114	124	–
28	52	52	40	76	76	58	88	96	78	77	77	59	109	110	84	110	119	–
29	47	47	36	69	69	52	85	92	71	70	70	53	100	100	76	106	115	102
30	43	43	32	62	62	47	82	84	64	63	63	48	91	91	69	102	111	93
31				56	56	43	76	76	58	57	57	44	82	82	63	99	108	85
32				51	51	39	69	69	53	52	52	40	75	75	57	96	101	77
33				47	47	36	63	63	48	48	48	36	69	69	52	92	92	71
34				43	43	33	58	58	44	44	44	33	63	63	48	85	85	65
35							53	53	41	40	40	31	58	58	44	78	78	59

**NOTES**

- ▶ Total Load values are limited by shear, moment, or deflection equal to L/180.
- ▶ Deflection values are limited by live load deflection equal to L/240. Check the local building code for other deflection limits that may apply.
- ▶ Both the Total Load and Deflection columns must be checked. Where a deflection value is not shown, the total load value will control.
- ▶ Table values assume minimum bearing lengths without web stiffeners for joist depths of 16" and less.
- ▶ Slope roof joists at least ¼:12 to minimize ponding.
- ▶ Table values apply to either simple or multiple span joists. Span is measured center-to-center of the minimum required bearing length. Analyze multiple span joists with the BC Calc® software if the length of any span is less than half the length of an adjacent span.
- ▶ This table was designed to apply to a broad range of applications. It may be possible to exceed the limitations of this table by analyzing a specific application with the BC Calc® software.
- ▶ Allowable spans and loads shall be adjusted and checked for wind load as required by local building code.

# BCI Joist Design Properties

BCI® Joist Series	Joist Depth	Weight (PLF)	Moment (ft-lbs)	EI x 10 <sup>6</sup> (lb-in <sup>2</sup> )	K x 10 <sup>6</sup> (lbs)	Shear (lbs)	End Reaction (lbs)				Intermediate Reaction (lbs)			
							1½" Bearing		3½" Bearing		3½" Bearing		5¼" Bearing	
							No WS <sup>(1)</sup>	WS <sup>(2)</sup>	No WS <sup>(1)</sup>	WS <sup>(2)</sup>	No WS <sup>(1)</sup>	WS <sup>(2)</sup>	No WS <sup>(1)</sup>	WS <sup>(2)</sup>
4500s 1.8	9½"	2.1	2,360	155	5	1,475	950	1,125	1,125	1,275	2,100	2,350	2,525	2,750
	11⅞"	2.4	3,025	260	6	1,625	950	1,425	1,425	1,475	2,250	2,850	2,525	3,000
	14"	2.7	3,585	380	8	1,825	950	1,525	1,450	1,725	2,350	3,050	2,525	3,200
	16"	3	4,090	515	9	1,975	950	1,625	1,475	1,975	2,400	3,200	2,525	3,350
5000s 1.8	9½"	2.3	2,725	175	5	1,475	950	1,125	1,125	1,275	2,100	2,350	2,525	2,750
	11⅞"	2.6	3,485	295	6	1,625	950	1,425	1,425	1,475	2,250	2,850	2,525	3,000
	14"	2.9	4,130	430	8	1,825	950	1,525	1,475	1,725	2,350	3,050	2,525	3,200
	16"	3.1	4,715	580	9	1,975	950	1,625	1,500	1,975	2,400	3,200	2,525	3,350
6000s 1.8	9½"	2.5	3,165	200	5	1,575	1,175	1,375	1,375	1,425	2,400	2,650	2,700	2,750
	11⅞"	2.8	4,060	335	6	1,675	1,175	1,425	1,425	1,475	2,500	2,850	2,900	3,000
	14"	3.1	4,815	490	8	1,925	1,175	1,525	1,525	1,725	2,600	3,150	2,925	3,200
	16"	3.3	5,495	660	9	2,175	1,175	1,625	1,550	1,975	2,650	3,350	2,950	3,350
6500s 1.8	9½"	2.7	3,505	220	5	1,575	1,175	1,375	1,375	1,425	2,400	2,650	2,700	2,750
	11⅞"	3	4,495	365	7	1,675	1,175	1,425	1,425	1,475	2,500	2,850	2,900	3,000
	14"	3.3	5,330	535	8	1,925	1,175	1,525	1,525	1,725	2,600	3,150	2,925	3,200
	16"	3.5	6,085	720	9	2,175	1,175	1,625	1,550	1,975	2,650	3,350	2,950	3,350
60s 2.0	11⅞"	3.2	6,235	450	7	1,675	1,175	1,425	1,425	1,475	2,750	2,850	3,200	3,250
	14"	3.5	7,440	660	8	1,925	1,175	1,525	1,525	1,725	2,750	3,450	3,200	3,650
	16"	3.8	8,520	895	9	2,175	1,175	1,625	1,550	1,975	2,750	3,650	3,200	3,750
90s 2.0	11⅞"	4.3	9,550	675	7	2,150	1,425	1,850	1,800	1,950	3,375	3,700	4,000	4,350
	14"	4.6	11,390	980	8	2,350	1,450	1,950	1,850	2,150	3,400	3,850	4,100	4,450
	16"	4.9	13,050	1,330	9	2,550	1,475	2,150	1,900	2,350	3,425	4,000	4,200	4,650

- (1) No web stiffeners required.  
 (2) Web stiffeners required.

**NOTES**

- Moment, shear and reaction values based upon a load duration of 100% and may be adjusted for other load durations.
- Design values listed are applicable for Allowable Stress Design (ASD).
- No additional repetitive member increase allowed.

$$\Delta = \frac{5wl^4}{384EI} + \frac{wl^2}{K}$$

$\Delta$  = deflection (in)       $EI$  = bending stiffness (lb-in<sup>2</sup>)  
 $w$  = uniform load (lb/in)       $K$  = shear deformation coefficient (lb)  
 $l$  = clear span (in)

Code Evaluation Report: ICC-ES®/APA® ESR-1336 (IBC®, IRC®)

## Closest Allowable Nail Spacing

Nail Size	All BCI® Joists			
	Nailing Perpendicular to Glue Line (Wide Face)		Nailing Parallel to Glue Line (Narrow Face)	
	O.C. Spacing	End of Joist	O.C. Spacing	End of Joist
8d Box (0.113"ø x 2.5")	2"	1½"	4"	1½"
8d Common (0.131"ø x 2.5")	2"	1½"	4"	3"
10d & 12d Box (0.128"ø x 3", 3.25")	2"	1½"	4"	3"
16d Box (0.135"ø x 3.5")	2"	1½"	4"	3"
10d & 12d Common and 16d Sinker (0.148"ø x 3", 3.25")	3"	2"	6"	4"
16d Common (0.162"ø x 3.5")	3"	2"	6"	4"

**NOTES**

- If more than one row of nails is used, the rows must be offset at least ½".
- Connectors that mount to sides of flanges (such as Simpson Strong-Tie A35) may only be used on BCI® 60s and 90s joist flanges. Use nails as specified by Simpson Strong-Tie; do not attach connectors on both sides of a flange at the same location.

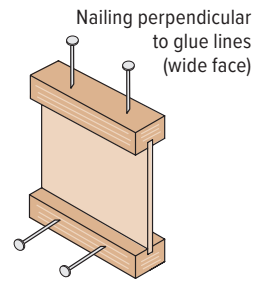

Nailing perpendicular to glue lines (wide face)  
 Nailing parallel to glue lines (narrow face)

**BCI® Diaphragm Table<sup>(1)</sup>**

BCI® Series	Diaphragm Capacity (lb/ft) <sup>(2) (3)</sup>	
	Unblocked	Blocked
4500s, 5000s	As permitted for 2x framing in building code	320 lb/ft for 6" o.c. nailing at panel edges 425 lb/ft for 4" o.c. nailing, staggered, at panel edges
6000s, 6500s	As permitted for 3x framing in building code	360 lb/ft for 6" o.c. nailing at panel edges 480 lb/ft for 4" o.c. nailing, staggered at panel edges
60s, 90s	As permitted for 3x framing in building code	As permitted for 3x framing in building code not to exceed 690 lb/ft.

**NOTES**

- (1) See ICC-ES®/APA® ESR-1336, Table 7.
- (2) As noted in table, BCI® joists may be substituted for solid sawn framing in horizontal wood diaphragms as shown in ANSI/AWC SDPWS, Tables 4.2A and 4.2C (referenced in IBC).
- (3) Diaphragm nailing shall not exceed the limits of BCI® joist closest allowable nail spacing.

# Rim Board Details and Properties

## Rim Board Product Profiles

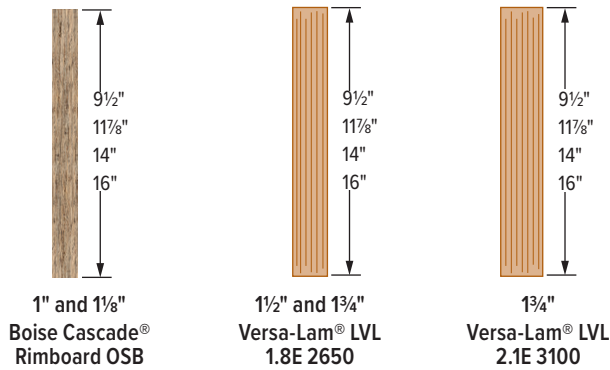

F07

### Perpendicular

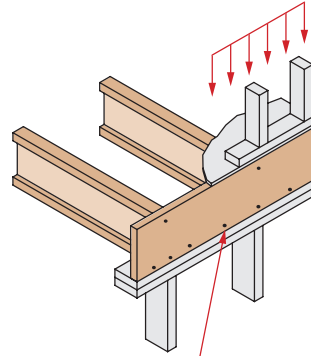

- ▶ Rim board: min. 8d nails at 6" o.c. per IRC. Connection per design professional of record's specification for shear transfer.
- ▶ See table for vertical load capacity

F07A

### Parallel

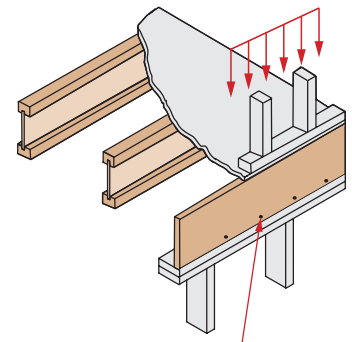

- ▶ Rim board: min. 8d nails at 6" o.c. per IRC. Connection per design professional of record's specification for shear transfer.
- ▶ See table for vertical load capacity

F56

## Rim Board with Ledger Attachment

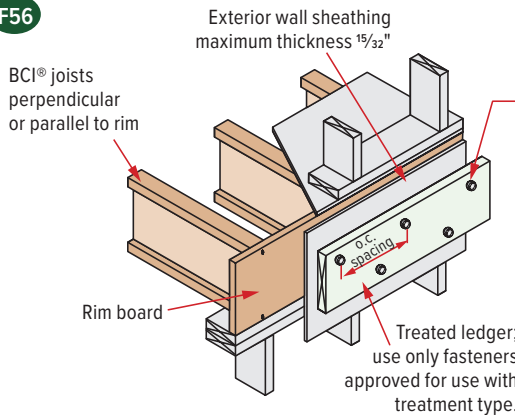

1/2" diameter through bolts (ASTM A307 Grades A & B, SAE J429 Grades 1 or 2, or higher with washer and nuts) or 1/2" diameter lag screws (full penetration), staggered.

Minimum connection for 40/10 psf deck loading:

Deck Joist Length	Connection
12'-0" and less	2 rows 1/2" bolts or lag screws, 24" o.c. (300 PLF max.)
12'-1" to 18'-0"	2 rows 1/2" bolts or lag screws, 16" o.c. (450 PLF max.)

For snow loads greater than 40 psf and/or dead loads greater than 10 psf, size connection per max. PLF values shown above.

### NOTES

- ▶ Design of moisture control by others (only structural components shown above).
- ▶ For information on deck lateral load connections per IRC section R507.2.3, contact Boise Cascade EWP Engineering.
- ▶ For use of proprietary screws to attach ledger, consult screw manufacturer literature.
- ▶ For further information on residential deck design, see AWC DCA 6 *Prescriptive Residential Wood Deck Construction Guide*.

## Rim Board Properties

Product	Vertical Load Capacity		Maximum Floor Diaphragm Lateral Capacity (lb/ft)	Specific Gravity for Lateral Nail Design	Allowable Design Values			
	Uniform (PLF)	Point (lb)			Flexural Stress (lb/in <sup>2</sup> )	Modulus of Elasticity—True (lb/in <sup>2</sup> )	Horizontal Shear (lb/in <sup>2</sup> )	Compression Perpendicular to Grain (lb/in <sup>2</sup> )
1" Boise Cascade® Rimboard OSB (C2) <sup>(1)</sup>	3,300	3,500	180	0.5	Limited span capabilities, see Note 1			
1 1/8" Boise Cascade® Rimboard OSB (C1) <sup>(1)</sup>	4,850	3,500	180					
1 1/2" and 1 3/4" Versa-Lam® LVL 1.8E 2650 <sup>(2)</sup>	4,250	3,700	Permitted per building code for all nominal 2" thick framing blocked and unblocked diaphragms (4" nail spacing and greater)		2,650	1,800,000	285	750
1 3/4" Versa-Lam® LVL 2.1E 3100 <sup>(2)</sup>	5,700	4,300			3,100	2,100,000	285	750

(1) Rim board grades C1 and C2 per APA Form W345 U.S. Edition *APA Performance-Rated Rim Boards*.

(2) See ICC-ES/APA ESR-1040 for more information.

## Closest Allowable Nail Spacing (Narrow Face)

Nail Size	Boise Cascade® Rimboard OSB <sup>(1)</sup>		Versa-Lam® LVL Rim Board <sup>(2)</sup>	
	1"	1 1/8"	1 1/2"	1 3/4"
8d box (0.113"ø x 2.5")	3"	3"	3"	2"
8d common (0.131"ø x 2.5")	3"	3"	3"	3"
10d and 12d box (0.128"ø x 3", 3.25")	See publication listed in note (1) for additional nailing information.		3"	3"
16d box (0.135"ø x 3.5")			3"/5"	3"/5"
10d and 12d common and 16d sinker (0.148"ø x 3", 3.25")			4"/6"	4"/6"
16d common (0.162"ø x 3.5")			6"/8"	6"/8"

Red numbers indicate different nail spacing for Versa-Lam® LVL manufactured in Thorsby, AL.

(1) See *Performance Rated Rim Boards*, APA Form #W345 for more product information.

(2) See ICC-ES/APA ESR-1040 for more information.

# Versa-Lam LVL Product Profiles

When you specify headers and beams made of Versa-Lam® laminated veneer lumber (LVL), you are building quality into your design. They are excellent for floor and roof framing supports and as headers for doors, windows, and garage doors. Versa-Lam® LVL can even be used in column applications. Because they have no camber, Versa-Lam® LVL products provide flatter, quieter floors—which helps ensure happier customers and significantly fewer builder call backs.

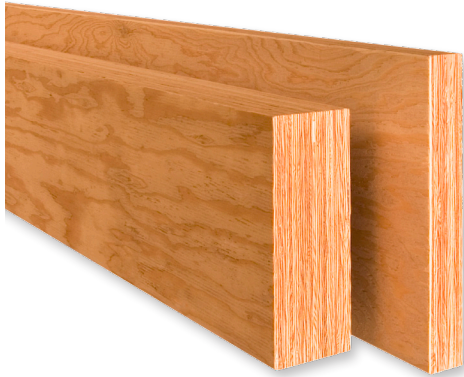

Versa-Lam® LVL products shall be installed in dry-use applications only, per their respective ICC-ES/APA ESR evaluation reports.

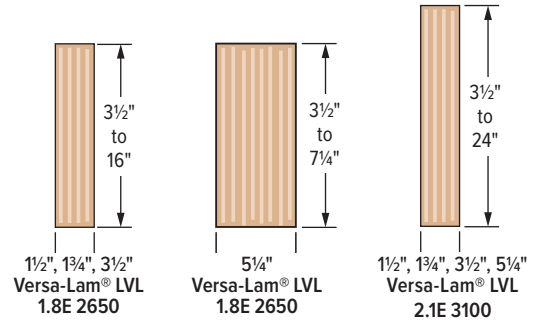

Some products may not be available in all markets. Contact your Boise Cascade EWP representative for availability.

## Architectural Specifications

**Scope** — This work includes the complete furnishing and installation of all Versa-Lam® LVL beams as shown on the drawings, herein specified and necessary to complete the work.

**Materials** — Southern Pine or Douglas fir veneers, laminated in a press with all grain parallel with the length of the member. Glues used in lamination are phenol formaldehyde and isocyanate exterior-type adhesives which comply with ASTM D2559.

**Design** — Versa-Lam® LVL beams shall be sized and detailed to fit the dimensions and loads indicated on the plans. All designs shall be in accordance with allowable values developed in accordance with ASTM D5456 and listed in

the governing code evaluation service's report and section properties based upon standard engineering principles. Verification of design of the Versa-Lam® LVL beams by complete calculations shall be available upon request.

**Drawings** — Additional drawings showing layout and detail necessary for determining fit and placement in the buildings are (are not) to be provided by the supplier.

**Fabrication** — Versa-Lam® LVL beams shall be manufactured in a plant evaluated for fabrication by the governing code evaluation service and under the supervision of a third-party inspection agency listed by the corresponding evaluation service.

**Storage and Installation** — Versa-Lam® LVL beams, if stored prior to erection, shall be stored on stickers spaced a maximum of 15 ft. apart. Beams shall be stored on a dry, level surface and protected from the weather. They shall be handled with care so they are not damaged.

Versa-Lam® LVL beams are to be installed in accordance with the plans and Boise Cascade EWP's Installation Guide. Temporary construction loads which cause stresses beyond design limits are not permitted. Erection bracing shall be provided to assure adequate lateral support for the individual beams and the entire system until the sheathing material has been applied.

**Codes** — Versa-Lam® LVL beams shall be evaluated by a model code evaluation service.

## Versa-Lam LVL Allowable Holes

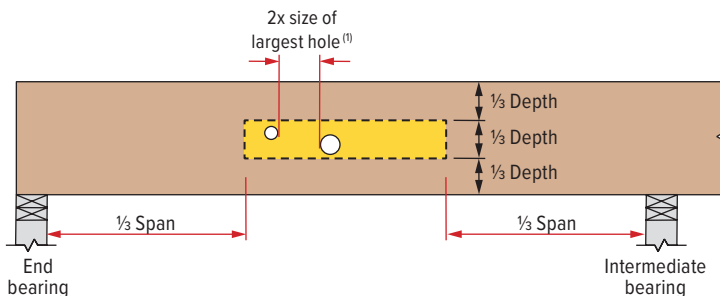

### Allowable Round Holes

Table valid only for beams supporting uniform load.

Beam Depth	Max. Hole Diameter
5 1/2"	3/4"
7 1/4"	1"
9 1/4" and greater	2"

### NOTES

- (1) The horizontal distance between adjacent holes must be at least two times the diameter of the larger hole. This restriction also applies to the location of holes relative to bolt holes in multiple ply beams. Holes shall not be stacked vertically.
  - ▶ Round holes may be drilled or cut with a hole saw anywhere within the shaded area of the beam.
  - ▶ Square and rectangular holes are not permitted.
  - ▶ Do not drill more than three access holes in any four foot long section of beam.
  - ▶ These limitations apply to holes drilled for plumbing or wiring access only. The size and location of holes drilled for fasteners are governed by the provisions of the *National Design Specification® for Wood Construction*.
  - ▶ Beams deflect under load. Size holes to provide clearance where required.
  - ▶ **Allowable Round Holes** table at left is valid for beams supporting uniform load only. For beams supporting concentrated loads or beams with larger holes, use BC Calc® software or contact Boise Cascade EWP Engineering.

# Versa-Lam LVL Beam Details

<p><b>Bearing At Concrete/Masonry Walls</b></p> <p>1/2" air space required between concrete and wood</p> <p><b>B01</b> Provide moisture barrier and lateral restraint at bearing</p>	<p><b>Bearing For Door Or Window Header</b></p> <p>Strap per code if top plate is not continuous over header.</p> <p>Trimmer studs provide bearing across full width of beam.</p> <p><b>B02</b></p>	<p><b>Beam To Beam Connector</b></p> <p>Verify hanger capacity with hanger manufacturer</p> <p><b>B03</b></p>	<p><b>Bearing At Column</b></p> <p>Versa-Lam® LVL column</p> <p>Column connector per design profession of record</p> <p><b>B04</b></p>
<p><b>Slope Seat Cut</b></p> <p>Sloped seat cut. Not to exceed inside face of bearing</p> <p>Blocking not shown for clarity</p> <p><b>B06</b></p>	<p><b>Bevel Cut</b></p> <p><b>DO NOT</b> bevel cut Versa-Lam LVL beyond inside face of wall without approval from Boise Cascade EWP Engineering or BC Calc software analysis.</p> <p><b>B07</b></p>	<p><b>Beam To Concrete/Masonry Walls</b></p> <p>Wood top plate must be flush with inside of wall</p> <p>Hanger</p> <p>Moisture barrier between concrete and wood</p> <p><b>B08</b></p>	<p><b>Bearing Framing Into Wall</b></p> <p>Strap per code if top plate is not continuous</p> <p><b>B09</b></p>

**NOTES**

- ▶ Minimum of 1/2" air space between beam and wall pocket or adequate barrier must be provided between beam and concrete/masonry.
- ▶ Adequate bearing shall be provided. If not shown on plans, please refer to load tables on pages 28 – 30 of this guide.
- ▶ Versa-Lam® LVL beams are intended for interior applications only and should be kept as dry as possible during construction.
- ▶ Continuous lateral support of top of beam shall be provided (side or top bearing framing).

## Versa-Lam LVL Beam Multiple Member Connections

**Side-Loaded Applications — Maximum uniform side load (PLF)**

Number of Plies	Nailed <sup>(3)</sup>			1/2" Dia. Through Bolt <sup>(1)</sup>			5/8" Dia. Through Bolt <sup>(1)</sup>		
	2 Rows 16d Sinkers @ 12" o.c.	3 Rows 16d Sinkers @ 12" o.c.	2 Rows @ 24" o.c. Staggered	2 Rows @ 24" o.c. Staggered	2 Rows @ 12" o.c. Staggered	2 Rows @ 24" o.c. Staggered	2 Rows @ 12" o.c. Staggered	2 Rows @ 12" o.c. Staggered	
<b>1 3/4" Versa-Lam® LVL (Depths of 18" and less)</b>									
2	470	705	505	1,010	2,020	560	1,120	2,245	
3 <sup>(2)</sup>	350	525	375	755	1,515	420	840	1,685	
4 <sup>(4)</sup>	Use bolt schedule		335	670	1,345	370	745	1,495	
<b>3 1/2" Versa-Lam® LVL</b>									
2 <sup>(4)</sup>	Use bolt schedule		855	1,715	N/A	1,125	2,250	N/A	
Number of Plies	Nailed <sup>(3)</sup>		1/2" Dia. Through Bolt <sup>(1)</sup>			5/8" Dia. Through Bolt <sup>(1)</sup>			
	3 Rows 16d Sinkers @ 12" o.c.	4 Rows 16d Sinkers @ 12" o.c.	3 Rows @ 24" o.c. 8" Staggered	3 Rows @ 18" o.c. 6" Staggered	3 Rows @ 12" o.c. 4" Staggered	3 Rows @ 24" o.c. 8" Staggered	3 Rows @ 18" o.c. 6" Staggered	3 Rows @ 12" o.c. 4" Staggered	
<b>1 3/4" Versa-Lam® LVL (Depths of 24" and less)</b>									
2	705	940	755	1,010	1,515	840	1,120	1,685	
3 <sup>(2)</sup>	525	705	565	755	1,135	630	840	1,260	
4 <sup>(4)</sup>	Use bolt schedule		505	670	1,010	560	745	1,120	

**Top-Loaded Applications — For top-loaded beams and beams with side loads less than those shown in table above.**

Plies	Depth	Number of Rows	Fastening <sup>(1)(2)</sup>	Maximum Uniform Load From One Side
Two 1 3/4" plies	Depths 11 7/8" & less	2	16d box/sinker nails @ 12" o.c.	400 PLF
	Depths 14" - 18"	3		600 PLF
	Depth = 24"	4		800 PLF
Three 1 3/4" plies <sup>(2)</sup>	Depths 11 7/8" & less	2		300 PLF
	Depths 14"-18"	3		450 PLF
	Depth = 24"	4		600 PLF
Four 1 3/4" plies	Depths 18" & less	2	2 rows 1/2" bolts @ 24" o.c., staggered	335 PLF
	Depth = 24"	3	3 rows 1/2" bolts @ 24" o.c., staggered every 8"	505 PLF
Two 3 1/2" plies	Depths 18" & less	2	2 rows 1/2" bolts @ 24" o.c., staggered	855 PLF
	Depth 20"-24"	3	3 rows 1/2" bolts @ 24" o.c., staggered every 8"	1,285 PLF

- (1) Design values apply to common bolts that conform to ANSI/ASME standard B18.21-1981 (ASTM A307 Grades A&B, SAE J429 Grades 1 or 2, or higher). A washer not less than a standard cut washer shall be between the wood and the bolt head and between the wood and the nut. The distance from the edge of the beam to the bolt holes must be at least 2" for 1/2" bolts and 2 1/2" for 5/8" bolts. Bolt holes shall be the same diameter as the bolt.
- (2) The nail schedules shown apply to both sides of a 3-ply beam.
- (3) 16d box nails = 0.135" diameter x 3.5" length, 16d sinker nails = 0.148" diameter x 3.25" length.
- (4) 7" wide beams must be top-loaded or loaded from both sides (lesser side shall be no less than 25% of opposite side).

**NOTES**

- ▶ Beams wider than 7" must be designed by the engineer of record.
- ▶ All values in these tables may be increased by 15% for snow-load roofs and by 25% for non-snow load roofs where the building code allows.
- ▶ Use allowable load tables or BC Calc® software to size beams.
- ▶ An equivalent specific gravity of 0.5 may be used when designing specific connections with Versa-Lam® LVL.
- ▶ Connection values are based upon the NDS, 2018 Edition.
- ▶ FastenMaster TrussLOK®, Simpson Strong-Tie SDW or SDS, and MiTek WS screws may also be used to connect multiple member Versa-Lam® LVL beams. Contact Boise Cascade EWP Engineering for more information.

### Designing Connections For Multiple-Ply Versa-Lam® LVL Beams

When using multiple ply Versa-Lam® LVL beams to create a wider member, the connection of the plies is as critical as determining the beam size. When side loaded beams are not connected properly, the inside plies do not support their share of the load and thus the load-carrying capacity of the full member decreases significantly.

The following example shows how to size and connect a multiple-ply Versa-Lam® LVL floor beam.

**Given:** Beam with a 16'-0" span (shown above) supports a residential floor load (40 psf live load, 10 psf dead load). Beam depth is limited to 14".

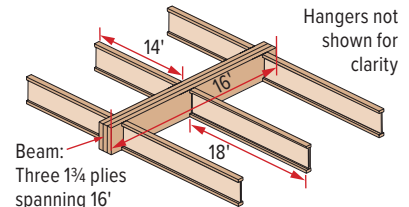

**Find:** A beam of multiple 1 3/4" plies of Versa-Lam® LVL that can support the design loads, plus the beam's proper connection schedule.

- Calculate tributary width and load the beam is supporting:  
 $14'/2 + 18'/2 = 16$  ft. tributary width  
 Live Load: 40 psf x 16 ft. = 640 PLF  
 Dead Load: 10 psf x 16 ft. = 160 PLF  
 Total Load: 640 PLF + 160 PLF = 800 PLF
- Use PLF table on page 28 or BC Calc® software to size the beam.  
 A 3-ply Versa-Lam® LVL 1 3/4" x 14" beam will adequately support the calculated design load.
- Calculate the maximum PLF load from longest side (18' in this case).  
 Max. Side Load =  $(18'/2) \times (40 + 10 \text{ psf}) = 450$  PLF
- See the Side-Loaded Applications table (at left) for 1 3/4" Versa-Lam® LVL, 3 plies.  
**Nailed:** 3 rows 16d sinkers at 12" o.c.: 525 PLF is greater than 450 PLF **OK**  
**Bolts:** 1/2" diameter 2 rows at 12" staggered: 755 PLF is greater than 450 PLF **OK**
- The proper connection schedule must have a capacity greater than the maximum side load:

# Versa-Lam LVL Beam Floor Load Table

**Table Key:** Top value = Allowable Total Load (PLF)  
 Middle value = Allowable Live Load (PLF)  
 Bottom value = Min. Required Bearing Length (inches) at End/Intermediate supports

Versa-Lam® LVL 2.1E 3100  
 (100% Load Duration)

Beam Span (ft)	1 3/4" Versa-Lam® LVL				3 1/2" Versa-Lam® LVL 2-Ply 1 3/4" or Single 3 1/2"						5 1/4" Versa-Lam® LVL 3-Ply 1 3/4" or Single 5 1/4"						7" Versa-Lam® LVL 4-Ply 1 3/4" or 2-Ply 3 1/2"					
	Beam Depth				Beam Depth						Beam Depth						Beam Depth					
	7 1/4"	9 1/2"	11 7/8"	14"	7 1/4"	9 1/2"	11 7/8"	14"	16"	18"	9 1/2"	11 7/8"	14"	16"	18"	20"	11 7/8"	14"	16"	18"	20"	24"
6	763	1,063	1,424	1,795	1,525	2,126	2,849	3,590	4,387	4,794	3,189	4,273	5,384	6,580	7,191	7,188	5,697	7,179	8,773	9,588	9,584	9,576
	693	-	-	-	1,385	-	-	-	-	-	-	-	-	-	-	-	-	-	-	-	-	-
7	1.8/4.4	2.4/6.1	3.3/8.2	4.1/10.3	1.8/4.4	2.4/6.1	3.3/8.2	4.1/10.3	5/12.6	5.5/13.8	2.4/6.1	3.3/8.2	4.1/10.3	5/12.6	5.5/13.8	5.5/13.8	3.3/8.2	4.1/10.3	5/12.6	5.5/13.8	5.5/13.8	5.5/13.8
	636	877	1,160	1,444	1,271	1,753	2,321	2,888	3,482	4,107	2,630	3,481	4,331	5,223	6,160	6,157	4,641	5,775	6,964	8,213	8,209	8,201
8	462	746	979	1,207	924	1,492	1,957	2,414	2,886	3,402	2,237	2,936	3,622	4,328	5,103	5,384	3,914	4,829	5,771	6,803	7,178	7,170
	310	660	-	-	621	1,321	-	-	-	-	1,981	-	-	-	-	-	-	-	-	-	-	-
9	1.5/3.5	2.3/5.7	3.7/7.5	3.7/9.3	1.5/3.5	2.3/5.7	3.7/7.5	3.7/9.3	4.4/11.1	5.2/13	2.3/5.7	3.7/7.5	3.7/9.3	4.4/11.1	5.2/13	5.5/13.8	3.7/7.5	3.7/9.3	4.4/11.1	5.2/13	5.5/13.8	5.5/13.8
	329	649	846	1,037	658	1,297	1,692	2,074	2,463	2,884	1,946	2,537	3,111	3,694	4,325	4,782	3,383	4,148	4,926	5,767	6,376	6,368
10	222	477	-	-	444	954	-	-	-	-	1,431	-	-	-	-	-	-	-	-	-	-	-
	1.5/3	2.2/5.6	2.9/7.3	3.6/8.9	1.5/3	2.2/5.6	2.9/7.3	3.6/8.9	4.3/10.6	5/12.4	2.2/5.6	2.9/7.3	3.6/8.9	4.3/10.6	5/12.4	5.5/13.8	2.9/7.3	3.6/8.9	4.3/10.6	5/12.4	5.5/13.8	5.5/13.8
11	242	527	745	909	484	1,055	1,489	1,817	2,148	2,502	1,582	2,234	2,726	3,222	3,753	4,301	2,978	3,635	4,296	5,003	5,734	5,726
	164	355	660	-	327	710	1,321	-	-	-	1,065	1,981	-	-	-	-	2,642	-	-	-	-	-
12	1.5/3	2/5.1	2.9/7.1	3.5/8.7	1.5/3	2/5.1	2.9/7.1	3.5/8.7	4.1/10.3	4.8/12	2/5.1	2.9/7.1	3.5/8.7	4.1/10.3	4.8/12	5.5/13.8	2.9/7.1	3.5/8.7	4.1/10.3	4.8/12	5.5/13.8	5.5/13.8
	183	401	665	808	365	803	1,330	1,617	1,904	2,209	1,204	1,995	2,425	2,856	3,313	3,800	2,659	3,233	3,807	4,417	5,067	5,201
13	124	271	508	798	248	541	1,015	1,595	-	-	812	1,523	2,393	-	-	-	2,031	3,190	-	-	-	-
	1.5/3	1.7/4.3	2.8/7	3.4/8.5	1.5/3	1.7/4.3	2.8/7	3.4/8.5	4/10.1	4.7/11.7	1.7/4.3	2.8/7	3.4/8.5	4/10.1	4.7/11.7	5.4/13.4	2.8/7	3.4/8.5	4/10.1	4.7/11.7	5.4/13.4	5.5/13.8
14	141	312	585	728	282	623	1,170	1,456	1,709	1,977	935	1,755	2,184	2,564	2,965	3,390	2,340	2,912	3,418	3,953	4,519	4,764
	96	211	398	628	193	423	796	1,258	-	-	633	1,194	1,887	-	-	-	1,592	2,517	-	-	-	-
15	1.5/3	1.5/3.6	2.7/6.8	3.4/8.4	1.5/3	1.5/3.6	2.7/6.8	3.4/8.4	3.9/9.9	4.6/11.4	1.5/3.6	2.7/6.8	3.4/8.4	3.9/9.9	4.6/11.4	5.2/13	2.7/6.8	3.4/8.4	3.9/9.9	4.6/11.4	5.2/13	5.5/13.8
	111	246	470	662	221	493	941	1,324	1,550	1,789	739	1,411	1,986	2,326	2,683	3,059	1,881	2,647	3,101	3,577	4,078	4,394
16	76	168	318	504	152	335	635	1,009	1,456	-	503	953	1,513	2,185	-	-	1,270	2,017	2,913	-	-	-
	1.5/3	1.5/3.1	2.4/5.9	3.3/8.3	1.5/3	1.5/3.1	2.4/5.9	3.3/8.3	3.9/9.7	4.5/11.2	1.5/3.1	2.4/5.9	3.3/8.3	3.9/9.7	4.5/11.2	5.1/12.7	2.4/5.9	3.3/8.3	3.9/9.7	4.5/11.2	5.1/12.7	5.5/13.8
17	88	198	380	585	176	396	759	1,171	1,418	1,633	594	1,139	1,756	2,128	2,449	2,786	1,519	2,342	2,837	3,265	3,715	4,076
	61	135	257	410	123	270	514	820	1,189	-	405	771	1,230	1,783	-	-	1,029	1,640	2,378	-	-	-
18	1.5/3	1.5/3	2.1/5.1	3.2/7.9	1.5/3	1.5/3	2.1/5.1	3.2/7.9	3.8/9.6	4.4/11	1.5/3	2.1/5.1	3.2/7.9	3.8/9.6	4.4/11	5/12.5	2.1/5.1	3.2/7.9	3.8/9.6	4.4/11	5/12.5	5.5/13.8
	71	161	310	499	143	322	621	998	1,307	1,502	483	931	1,497	1,960	2,253	2,558	1,242	1,997	2,614	3,003	3,410	3,801
19	50	111	211	338	100	221	422	675	982	1,359	332	633	1,013	1,473	2,039	-	844	1,350	1,964	2,718	-	-
	1.5/3	1.5/3	1.8/4.5	2.9/7.2	1.5/3	1.5/3	1.8/4.5	2.9/7.2	3.8/9.5	4.3/10.9	1.5/3	1.8/4.5	2.9/7.2	3.8/9.5	4.3/10.9	4.9/12.3	1.8/4.5	2.9/7.2	3.8/9.5	4.3/10.9	4.9/12.3	5.5/13.8
20	58	132	257	414	117	265	514	829	1,151	1,390	397	770	1,243	1,727	2,085	2,364	1,027	1,658	2,303	2,780	3,151	3,561
	41	92	175	281	83	183	350	562	820	1,138	275	526	843	1,230	1,707	2,279	701	1,124	1,640	2,277	3,038	-
21	1.5/3	1.5/3	1.6/4	2.6/6.4	1.5/3	1.5/3	1.6/4	2.6/6.4	3.6/8.9	4.3/10.7	1.5/3	1.6/4	2.6/6.4	3.6/8.9	4.3/10.7	4.9/12.2	1.6/4	2.6/6.4	3.6/8.9	4.3/10.7	4.9/12.2	5.5/13.8
	110	214	347	96	220	429	695	1,018	1,274	330	643	1,042	1,527	1,911	2,196	2,588	858	1,389	2,036	2,547	2,929	3,348
22	77	147	236	69	153	294	473	691	962	230	441	709	1,037	1,443	1,931	588	945	1,382	1,924	2,575	-	-
	1.5/3	1.5/3.6	2.3/5.7	1.5/3	1.5/3	1.5/3.6	2.3/5.7	3.3/8.4	4.2/10.5	1.5/3	1.5/3.6	2.3/5.7	3.3/8.4	4.2/10.5	4.8/12	1.5/3.6	2.3/5.7	3.3/8.4	4.2/10.5	4.8/12	5.5/13.8	
23	92	181	294	80	185	361	587	865	1,134	277	542	881	1,298	1,701	2,051	723	1,175	1,731	2,268	2,735	3,160	-
	65	124	201	58	130	249	401	588	820	194	373	602	882	1,230	1,650	498	802	1,176	1,640	2,200	-	-
24	1.5/3	1.5/3.2	2.1/5.2	1.5/3	1.5/3	1.5/3.2	2.1/5.2	3/7.6	4/9.9	1.5/3	1.5/3.2	2.1/5.2	3/7.6	4/9.9	4.8/11.9	1.5/3.2	2.1/5.2	3/7.6	4/9.9	4.8/11.9	5.5/13.8	
	78	153	250	67	156	307	500	739	1,016	234	460	751	1,109	1,524	1,863	614	1,001	1,479	2,032	2,484	2,991	-
25	55	106	172	50	110	213	343	504	704	166	319	515	756	1,056	1,420	425	686	1,008	1,408	1,893	-	-
	1.5/3	1.5/3	1.9/4.7	1.5/3	1.5/3	1.5/3	1.9/4.7	2.7/6.8	3.7/9.4	1.5/3	1.5/3	1.9/4.7	2.7/6.8	3.7/9.4	4.6/11.4	1.5/3	1.9/4.7	2.7/6.8	3.7/9.4	4.6/11.4	5.5/13.8	
26	66	131	215	57	133	263	429	636	895	199	394	644	954	1,343	1,678	525	859	1,272	1,790	2,237	2,839	-
	47	92	148	43	95	183	296	435	609	142	275	444	652	913	1,230	366	592	870	1,218	1,640	2,718	-
27	1.5/3	1.5/3	1.7/4.2	1.5/3	1.5/3	1.5/3	1.7/4.2	2.5/6.2	3.5/8.7	1.5/3	1.5/3	1.7/4.2	2.5/6.2	3.5/8.7	4.3/10.8	1.5/3	1.7/4.2	2.5/6.2	3.5/8.7	4.3/10.8	5.5/13.8	
	98	161	-	-	98	196	322	479	678	147	293	483	719	1,016	1,379	391	644	959	1,355	1,839	2,576	-
28	69	112	-	-	72	138	224	330	464	107	208	336	496	696	940	277	448	661	928	1,253	2,091	-
	1.5/3	1.5/3.5	-	-	1.5/3	1.5/3	1.5/3.5	2.1/5.2	2.9/7.3	1.5/3	1.5/3	1.5/3.5	2.1/5.2	2.9/7.3	3.9/9.8	1.5/3	1.5/3.5	2.1/5.2	2.9/7.3	3.9/9.8	5.5/13.8	
29	74	123	-	-	73	149	246	369	523	110	223	370	553	785	1,070	297	493	738	1,047	1,426	2,184	-
	54	87	-	-	55	107	174	257	361	83	161	261	385	542	733	214	348	513	722	978	1,640	-
30	1.5/3	1.5/3	-	-	1.5/3	1.5/3	1.5/3	1.8/4.4	2.5/6.2	1.5/3	1.5/3	1.5/3	1.8/4.4	2.5/6.2	3.4/8.4	1.5/3	1.5/3	1.8/4.4	2.5/6.2	3.4/8.4	5.1/12.8	
	57	96	-	-	56	115	192	289	411	84	172	288	433	617	844	230	384	577	823	1,125	1,853	-
31	42	69	-	-	44	85	137	203	286	65	127	206	305	430	583	169	275	407	573	777	1,308	-
	1.5/3	1.5/3	-	-	1.5/3	1.5/3	1.5/3	1.5/3.8	2.1/5.3	1.5/3	1.5/3	1.5/3	1.5/3.8	2.1/5.3	2.9/7.2	1.5/3	1.5/3	1.5/3.8	2.1/5.3	2.9/7.2	4.7/11.8	
32	76	-	-	-	90	151	229	328	64	135	227	344	492	675	180	303	458	656	900	1,541	-	
	55	-	-	-	68	110	164	231	53	102	166	245	346	470	136	221	327					

# Versa-Lam LVL Beam Snow Roof Load Table

**Table Key:** Top value = Allowable Total Load (PLF)  
 Middle value = Allowable Live Load (PLF)  
 Bottom value = Min. Required Bearing Length (inches) at End / Intermediate supports

Versa-Lam® LVL 2.1E 3100  
 Snow (115%) Load Duration

Beam Span (ft)	1¾" Versa-Lam® LVL				3½" Versa-Lam® LVL 2-Ply 1¾" or Single 3½"						5¼" Versa-Lam® LVL 3-Ply 1¾" or Single 5¼"						7" Versa-Lam® LVL 4-Ply 1¾" or 2-Ply 3½"					
	Beam Depth				Beam Depth						Beam Depth						Beam Depth					
	7¼"	9½"	11¾"	14"	7¼"	9½"	11¾"	14"	16"	18"	9½"	11¾"	14"	16"	18"	20"	11¾"	14"	16"	18"	20"	24"
6	878	1,223	1,639	2,065	1,755	2,446	3,278	4,130	4,796	4,794	3,669	4,917	6,195	7,194	7,191	7,188	6,556	8,260	9,592	9,588	9,584	9,576
	-	-	-	-	-	-	-	-	-	-	-	-	-	-	-	-	-	-	-	-	-	-
7	2/5	2.8/7	3.8/9.4	4.7/11.8	2/5	2.8/7	3.8/9.4	4.7/11.8	5.5/13.8	5.5/13.8	2.8/7	3.8/9.4	4.7/11.8	5.5/13.8	5.5/13.8	5.5/13.8	3.8/9.4	4.7/11.8	5.5/13.8	5.5/13.8	5.5/13.8	5.5/13.8
	731	1,009	1,335	1,661	1,463	2,018	2,670	3,323	4,007	4,107	3,027	4,006	4,984	6,010	6,160	6,157	5,341	6,646	8,013	8,213	8,209	8,201
8	678	-	-	1,357	-	-	-	-	-	-	-	-	-	-	-	-	-	-	-	-	-	-
	2/4.9	2.7/6.8	3.6/8.9	4.4/11.1	2/4.9	2.7/6.8	3.6/8.9	4.4/11.1	5.4/13.4	5.5/13.8	2.7/6.8	3.6/8.9	4.4/11.1	5.4/13.4	5.5/13.8	5.5/13.8	3.6/8.9	4.4/11.1	5.4/13.4	5.5/13.8	5.5/13.8	5.5/13.8
9	598	858	1,126	1,389	1,197	1,717	2,252	2,779	3,321	3,591	2,575	3,379	4,168	4,981	5,387	5,384	4,505	5,558	6,642	7,182	7,178	7,170
	466	-	-	-	931	-	-	-	-	-	-	-	-	-	-	-	-	-	-	-	-	-
10	1.8/4.6	2.6/6.6	3.5/8.6	4.3/10.6	1.8/4.6	2.6/6.6	3.5/8.6	4.3/10.6	5.1/12.7	5.5/13.8	2.6/6.6	3.5/8.6	4.3/10.6	5.1/12.7	5.5/13.8	5.5/13.8	3.5/8.6	4.3/10.6	5.1/12.7	5.5/13.8	5.5/13.8	5.5/13.8
	440	747	974	1,194	880	1,493	1,947	2,387	2,835	3,190	2,240	2,921	3,581	4,252	4,785	4,782	3,894	4,774	5,670	6,380	6,376	6,368
11	333	715	-	-	665	1,431	-	-	-	-	2,146	-	-	-	-	-	-	-	-	-	-	-
	1.5/3.8	2.6/6.4	3.4/8.4	4.1/10.3	1.5/3.8	2.6/6.4	3.4/8.4	4.1/10.3	4.9/12.2	5.5/13.8	2.6/6.4	3.4/8.4	4.1/10.3	4.9/12.2	5.5/13.8	5.5/13.8	3.4/8.4	4.1/10.3	4.9/12.2	5.5/13.8	5.5/13.8	5.5/13.8
12	324	637	857	1,046	648	1,274	1,714	2,092	2,472	2,869	1,912	2,571	3,138	3,709	4,304	4,301	3,429	4,184	4,945	5,738	5,734	5,726
	246	532	-	-	491	1,065	-	-	-	-	1,597	-	-	-	-	-	-	-	-	-	-	-
13	1.5/3.1	2.4/6.1	3.3/8.2	4/10	1.5/3.1	2.4/6.1	3.3/8.2	4/10	4.7/11.9	5.5/13.8	2.4/6.1	3.3/8.2	4/10	4.7/11.9	5.5/13.8	5.5/13.8	3.3/8.2	4/10	4.7/11.9	5.5/13.8	5.5/13.8	5.5/13.8
	245	526	765	931	489	1,052	1,531	1,861	2,192	2,543	1,577	2,296	2,792	3,288	3,814	3,907	3,062	3,723	4,383	5,085	5,209	5,201
14	186	406	762	-	372	812	1,523	-	-	-	1,218	2,285	-	-	-	-	3,046	-	-	-	-	-
	1.5/3	2.2/5.6	3.2/8.1	3.9/9.8	1.5/3	2.2/5.6	3.2/8.1	3.9/9.8	4.6/11.6	5.4/13.4	2.2/5.6	3.2/8.1	3.9/9.8	4.6/11.6	5.4/13.4	5.5/13.8	3.2/8.1	3.9/9.8	4.6/11.6	5.4/13.4	5.5/13.8	5.5/13.8
15	189	417	674	838	378	834	1,347	1,676	1,968	2,276	1,252	2,021	2,514	2,952	3,414	3,579	2,694	3,353	3,936	4,552	4,772	4,764
	144	317	597	-	289	633	1,194	-	-	-	950	1,791	-	-	-	-	2,389	-	-	-	-	-
16	1.5/3	1.9/4.8	3.1/7.8	3.9/9.7	1.5/3	1.9/4.8	3.1/7.8	3.9/9.7	4.5/11.3	5.2/13.1	1.9/4.8	3.1/7.8	3.9/9.7	4.5/11.3	5.2/13.1	5.5/13.8	3.1/7.8	3.9/9.7	4.5/11.3	5.2/13.1	5.5/13.8	5.5/13.8
	149	330	573	762	297	660	1,146	1,524	1,785	2,060	991	1,719	2,287	2,678	3,089	3,301	2,292	3,049	3,571	4,119	4,402	4,394
17	114	251	476	756	229	503	953	1,513	-	-	754	1,429	2,269	-	-	-	1,905	3,026	-	-	-	-
	1.5/3	1.7/4.1	2.9/7.2	3.8/9.5	1.5/3	1.7/4.1	2.9/7.2	3.8/9.5	4.5/11.2	5.1/12.9	1.7/4.1	2.9/7.2	3.8/9.5	4.5/11.2	5.1/12.9	5.5/13.8	2.9/7.2	3.8/9.5	4.5/11.2	5.1/12.9	5.5/13.8	5.5/13.8
18	119	265	493	674	238	531	987	1,349	1,634	1,880	796	1,480	2,023	2,450	2,821	3,063	1,973	2,697	3,267	3,761	4,084	4,076
	92	203	386	615	184	405	771	1,230	-	-	608	1,157	1,845	-	-	-	1,543	2,460	-	-	-	-
19	1.5/3	1.5/3.6	2.7/6.7	3.6/9.1	1.5/3	1.5/3.6	2.7/6.7	3.6/9.1	4.4/11	5.1/12.7	1.5/3.6	2.7/6.7	3.6/9.1	4.4/11	5.1/12.7	5.5/13.8	2.7/6.7	3.6/9.1	4.4/11	5.1/12.7	5.5/13.8	5.5/13.8
	96	216	416	586	193	432	832	1,173	1,505	1,730	649	1,248	1,759	2,258	2,595	2,857	1,664	2,346	3,011	3,459	3,809	3,801
20	75	166	317	506	150	332	633	1,013	1,473	-	497	950	1,519	2,210	-	-	1,266	2,025	2,946	-	-	-
	1.5/3	1.5/3.2	2.4/6	3.4/8.5	1.5/3	1.5/3.2	2.4/6	3.4/8.5	4.3/10.9	5/12.5	1.5/3.2	2.4/6	3.4/8.5	4.3/10.9	5/12.5	5.5/13.8	2.4/6	3.4/8.5	4.3/10.9	5/12.5	5.5/13.8	5.5/13.8
21	79	178	344	515	158	356	689	1,029	1,327	1,601	535	1,033	1,544	1,990	2,402	2,677	1,377	2,058	2,653	3,202	3,569	3,561
	62	137	263	421	124	275	526	843	1,230	-	412	788	1,264	1,845	-	-	1,051	1,686	2,460	-	-	-
22	1.5/3	1.5/3	2.1/5.3	3.2/7.9	1.5/3	1.5/3	2.1/5.3	3.2/7.9	4.1/10.2	4.9/12.3	1.5/3	2.1/5.3	3.2/7.9	4.1/10.2	4.9/12.3	5.5/13.8	2.1/5.3	3.2/7.9	4.1/10.2	4.9/12.3	5.5/13.8	5.5/13.8
	65	148	288	455	131	297	576	910	1,173	1,468	445	864	1,365	1,760	2,201	2,517	1,152	1,820	2,346	2,935	3,356	3,348
23	52	115	220	354	104	230	441	709	1,037	1,443	345	661	1,063	1,555	2,165	-	882	1,418	2,074	2,886	-	-
	1.5/3	1.5/3	1.9/4.8	3/7.5	1.5/3	1.5/3	1.9/4.8	3/7.5	3.9/9.6	4.8/12	1.5/3	1.9/4.8	3/7.5	3.9/9.6	4.8/12	5.5/13.8	1.9/4.8	3/7.5	3.9/9.6	4.8/12	5.5/13.8	5.5/13.8
24	55	125	243	394	109	249	486	788	1,045	1,307	374	729	1,182	1,567	1,961	2,364	972	1,576	2,089	2,614	3,151	3,160
	44	97	187	301	87	194	373	602	882	1,230	291	560	902	1,322	1,845	-	747	1,203	1,763	2,460	-	-
25	1.5/3	1.5/3	1.7/4.3	2.8/6.9	1.5/3	1.5/3	1.7/4.3	2.8/6.9	3.6/9.1	4.5/11.4	1.5/3	1.7/4.3	2.8/6.9	3.6/9.1	4.5/11.4	5.5/13.8	1.7/4.3	2.8/6.9	3.6/9.1	4.5/11.4	5.5/13.8	5.5/13.8
	46	106	207	336	92	211	413	672	936	1,171	317	620	1,008	1,404	1,757	2,147	827	1,344	1,872	2,342	2,862	2,991
26	37	83	160	257	74	166	319	515	756	1,056	249	479	772	1,133	1,584	2,130	638	1,029	1,511	2,112	2,839	-
	1.5/3	1.5/3	1.5/3.8	2.5/6.2	1.5/3	1.5/3	1.5/3.8	2.5/6.2	3.4/8.6	4.3/10.8	1.5/3	1.5/3.8	2.5/6.2	3.4/8.6	4.3/10.8	5.3/13.1	1.5/3.8	2.5/6.2	3.4/8.6	4.3/10.8	5.3/13.1	5.5/13.8
27	90	177	289	78	180	354	577	843	1,055	270	531	866	1,265	1,583	1,934	708	1,155	1,686	2,110	2,579	2,839	-
	71	137	222	64	142	275	444	652	913	214	412	666	979	1,370	1,845	549	887	1,305	1,827	2,460	-	-
28	1.5/3	1.5/3.5	2.3/5.6	1.5/3	1.5/3	1.5/3.5	2.3/5.6	3.3/8.2	4.1/10.2	1.5/3	1.5/3.5	2.3/5.6	3.3/8.2	4.1/10.2	5/12.5	1.5/3.5	2.3/5.6	3.3/8.2	4.1/10.2	5/12.5	5.5/13.8	
	67	132	217	57	134	265	434	645	869	200	397	651	967	1,303	1,593	529	868	1,289	1,738	2,124	2,576	-
29	54	104	168	48	107	208	336	496	696	161	311	504	743	1,044	1,410	415	672	991	1,392	1,880	-	-
	1.5/3	1.5/3	1.9/4.7	1.5/3	1.5/3	1.5/3	1.9/4.7	2.8/6.9	3.7/9.3	1.5/3	1.5/3	1.9/4.7	2.8/6.9	3.7/9.3	4.5/11.3	1.5/3	1.9/4.7	2.8/6.9	3.7/9.3	4.5/11.3	5.5/13.8	
30	51	101	167	42	101	202	333	497	704	152	303	500	746	1,056	1,334	404	667	994	1,408	1,779	2,357	-
	42	80	130	37	83	161	261	385	542	125	241	391	578	813	1,100	321	521	770	1,083	1,467	-	-
31	1.5/3	1.5/3	1.6/4	1.5/3	1.5/3	1.5/3	1.6/4	2.3/5.9	3.3/8.3	1.5/3	1.5/3	1.6/4	2.3/5.9	3.3/8.3	4.2/10.4	1.5/3	1.6/4	2.3/5.9	3.3/8.3	4.2/10.4	5.5/13.8	
	79	130	-	-	78	157	261	390	555	116	236	391	585	832	1,132	314	521	781	1,109	1,510	2,139	-
32	63	103	-	-	65	127	206	305	430	98	190	309	457	645	874	254	412	610	859	1,166	1,963	-
	1.5/3	1.5/3.4	-	-	1.5/3	1																

# Versa-Lam LVL Beam Non-Snow Roof Load Table

**Table Key:** Top value = Allowable Total Load (PLF)  
 Middle value = Allowable Live Load (PLF)  
 Bottom value = Min. Required Bearing Length (inches) at End/Intermediate supports

Versa-Lam® LVL 2.1E 3100  
 Non-Snow (125%) Load Duration

Beam Span (ft)	1 3/4" Versa-Lam® LVL				3 1/2" Versa-Lam® LVL 2-Ply 1 3/4" or Single 3 1/2"						5 1/4" Versa-Lam® LVL 3-Ply 1 3/4" or Single 5 1/4"						7" Versa-Lam® LVL 4-Ply 1 3/4" or 2-Ply 3 1/2"					
	Beam Depth				Beam Depth						Beam Depth						Beam Depth					
	7 1/4"	9 1/2"	11 7/8"	14"	7 1/4"	9 1/2"	11 7/8"	14"	16"	18"	9 1/2"	11 7/8"	14"	16"	18"	20"	11 7/8"	14"	16"	18"	20"	24"
6	954	1,330	1,782	2,245	1,908	2,660	3,564	4,491	4,796	4,794	3,990	5,346	6,736	7,194	7,191	7,188	7,128	8,981	9,592	9,588	9,584	9,576
	-	-	-	-	-	-	-	-	-	-	-	-	-	-	-	-	-	-	-	-	-	-
7	2.2/5.5	3.1/7.6	4.1/10.2	5.1/12.9	2.2/5.5	3.1/7.6	4.1/10.2	5.1/12.9	5.5/13.8	5.5/13.8	3.1/7.6	4.1/10.2	5.1/12.9	5.5/13.8	5.5/13.8	5.5/13.8	4.1/10.2	5.1/12.9	5.5/13.8	5.5/13.8	5.5/13.8	5.5/13.8
	795	1,097	1,452	1,807	1,591	2,194	2,904	3,613	4,109	4,107	3,291	4,356	5,420	6,163	6,160	6,157	5,807	7,226	8,217	8,213	8,209	8,201
8	678	-	-	-	1,357	-	-	-	-	-	-	-	-	-	-	-	-	-	-	-	-	-
	2.1/5.3	2.9/7.3	3.9/9.7	4.8/12.1	2.1/5.3	2.9/7.3	3.9/9.7	4.8/12.1	5.5/13.8	5.5/13.8	2.9/7.3	3.9/9.7	4.8/12.1	5.5/13.8	5.5/13.8	5.5/13.8	3.9/9.7	4.8/12.1	5.5/13.8	5.5/13.8	5.5/13.8	5.5/13.8
9	617	933	1,225	1,511	1,235	1,867	2,449	3,022	3,593	3,591	2,800	3,674	4,532	5,390	5,387	5,384	4,899	6,043	7,186	7,182	7,178	7,170
	466	-	-	-	931	-	-	-	-	-	-	-	-	-	-	-	-	-	-	-	-	-
10	1.9/4.7	2.9/7.1	3.8/9.4	4.6/11.6	1.9/4.7	2.9/7.1	3.8/9.4	4.6/11.6	5.5/13.8	5.5/13.8	2.9/7.1	3.8/9.4	4.6/11.6	5.5/13.8	5.5/13.8	5.5/13.8	3.8/9.4	4.6/11.6	5.5/13.8	5.5/13.8	5.5/13.8	5.5/13.8
	440	812	1,059	1,298	880	1,624	2,117	2,596	3,083	3,190	2,436	3,176	3,894	4,624	4,785	4,782	4,235	5,192	6,166	6,380	6,376	6,368
11	333	715	-	-	665	1,431	-	-	-	-	2,146	-	-	-	-	-	-	-	-	-	-	-
	1.5/3.8	2.8/7.7	3.7/9.1	4.5/11.2	1.5/3.8	2.8/7.7	3.7/9.1	4.5/11.2	5.3/13.3	5.5/13.8	3.7/9.1	4.5/11.2	5.3/13.3	5.5/13.8	5.5/13.8	5.5/13.8	3.7/9.1	4.5/11.2	5.3/13.3	5.5/13.8	5.5/13.8	5.5/13.8
12	324	693	932	1,138	648	1,386	1,864	2,275	2,689	2,869	2,079	2,797	3,413	4,033	4,304	4,301	3,729	4,550	5,378	5,738	5,734	5,726
	246	532	-	-	491	1,065	-	-	-	-	1,597	-	-	-	-	-	-	-	-	-	-	-
13	1.5/3.1	2.7/6.6	3.6/8.9	4.4/10.9	1.5/3.1	2.7/6.6	3.6/8.9	4.4/10.9	5.2/12.9	5.5/13.8	2.7/6.6	3.6/8.9	4.4/10.9	5.2/12.9	5.5/13.8	5.5/13.8	3.6/8.9	4.4/10.9	5.2/12.9	5.5/13.8	5.5/13.8	5.5/13.8
	245	537	833	1,012	489	1,073	1,665	2,024	2,384	2,607	1,610	2,498	3,037	3,576	3,910	3,907	3,330	4,049	4,767	5,213	5,209	5,201
14	186	406	762	-	372	812	1,523	-	-	-	1,218	2,285	-	-	-	-	3,046	-	-	-	-	-
	1.5/3	2.3/5.7	3.5/8.8	4.3/10.7	1.5/3	2.3/5.7	3.5/8.8	4.3/10.7	5/12.6	5.5/13.8	2.3/5.7	3.5/8.8	4.3/10.7	5/12.6	5.5/13.8	5.5/13.8	3.5/8.8	4.3/10.7	5/12.6	5.5/13.8	5.5/13.8	5.5/13.8
15	189	417	733	912	378	834	1,465	1,823	2,141	2,388	1,252	2,198	2,735	3,211	3,582	3,579	2,931	3,647	4,281	4,776	4,772	4,764
	144	317	597	-	289	633	1,194	-	-	-	950	1,791	-	-	-	-	2,389	-	-	-	-	-
16	1.5/3	1.9/4.8	3.4/8.4	4.2/10.5	1.5/3	1.9/4.8	3.4/8.4	4.2/10.5	4.9/12.3	5.5/13.8	1.9/4.8	3.4/8.4	4.2/10.5	4.9/12.3	5.5/13.8	5.5/13.8	3.4/8.4	4.2/10.5	4.9/12.3	5.5/13.8	5.5/13.8	5.5/13.8
	149	330	623	829	297	660	1,247	1,658	1,942	2,203	991	1,870	2,487	2,913	3,304	3,301	2,494	3,316	3,884	4,406	4,402	4,394
17	114	251	476	756	229	503	953	1,513	-	-	754	1,429	2,269	-	-	-	1,905	3,026	-	-	-	-
	1.5/3	1.7/4.1	3.1/7.8	4.1/10.4	1.5/3	1.7/4.1	3.1/7.8	4.1/10.4	4.8/12.1	5.5/13.8	1.7/4.1	3.1/7.8	4.1/10.4	4.8/12.1	5.5/13.8	5.5/13.8	3.1/7.8	4.1/10.4	4.8/12.1	5.5/13.8	5.5/13.8	5.5/13.8
18	119	265	508	734	238	531	1,017	1,467	1,777	2,044	796	1,525	2,201	2,666	3,066	3,063	2,033	2,934	3,554	4,088	4,084	4,076
	92	203	386	615	184	405	771	1,230	-	-	608	1,157	1,845	-	-	-	1,543	2,460	-	-	-	-
19	1.5/3	1.5/3.6	2.7/6.9	4/9.9	1.5/3	1.5/3.6	2.7/6.9	4/9.9	4.8/12	5.5/13.8	1.5/3.6	2.7/6.9	4/9.9	4.8/12	5.5/13.8	5.5/13.8	2.7/6.9	4/9.9	4.8/12	5.5/13.8	5.5/13.8	5.5/13.8
	96	216	416	638	193	432	832	1,276	1,638	1,882	649	1,248	1,914	2,456	2,823	2,857	2,552	3,275	3,763	3,809	3,801	-
20	75	166	317	506	150	332	633	1,013	1,473	-	497	950	1,519	2,210	-	-	1,266	20,25	2,946	-	-	-
	1.5/3	1.5/3.2	2.4/6	3.7/9.2	1.5/3	1.5/3.2	2.4/6	3.7/9.2	4.7/11.8	5.4/13.6	1.5/3.2	2.4/6	3.7/9.2	4.7/11.8	5.4/13.6	5.5/13.8	2.4/6	3.7/9.2	4.7/11.8	5.4/13.6	5.5/13.8	5.5/13.8
21	79	178	344	555	158	356	689	1,110	1,443	1,742	535	1,033	1,665	2,165	2,613	2,677	1,377	2,220	2,887	3,484	3,569	3,561
	62	137	263	421	124	275	526	843	1,230	1,707	412	788	1,264	1,845	2,561	-	1,051	1,686	2,460	3,415	-	-
22	1.5/3	1.5/3	2.1/5.3	3.4/8.6	1.5/3	1.5/3	2.1/5.3	3.4/8.6	4.4/11.1	5.4/13.4	1.5/3	2.1/5.3	3.4/8.6	4.4/11.1	5.4/13.4	5.5/13.8	2.1/5.3	3.4/8.6	4.4/11.1	5.4/13.4	5.5/13.8	5.5/13.8
	65	148	288	466	131	297	576	931	1,277	1,597	445	864	1,397	1,915	2,395	2,517	1,152	1,862	2,553	3,193	3,356	3,348
23	52	115	220	354	104	230	441	709	1,037	1,443	345	661	1,063	1,555	2,165	-	882	1,418	2,074	2,886	-	-
	1.5/3	1.5/3	1.9/4.8	3.1/7.7	1.5/3	1.5/3	1.9/4.8	3.1/7.7	4.2/10.5	5.2/13.1	1.5/3	1.9/4.8	3.1/7.7	4.2/10.5	5.2/13.1	5.5/13.8	1.9/4.8	3.1/7.7	4.2/10.5	5.2/13.1	5.5/13.8	5.5/13.8
24	55	125	243	394	109	249	486	788	1,137	1,422	374	729	1,182	1,705	2,133	2,376	972	1,576	2,274	2,845	3,168	3,160
	44	97	187	301	87	194	373	602	882	1,230	291	560	902	1,322	1,845	-	747	1,203	1,763	2,460	-	-
25	1.5/3	1.5/3	1.7/4.3	2.8/6.9	1.5/3	1.5/3	1.7/4.3	2.8/6.9	4/9.9	4.9/12.3	1.5/3	1.7/4.3	2.8/6.9	4/9.9	4.9/12.3	5.5/13.8	1.7/4.3	2.8/6.9	4/9.9	4.9/12.3	5.5/13.8	5.5/13.8
	46	106	207	336	92	211	413	672	991	1,275	317	620	1,008	1,487	1,912	2,249	827	1,344	1,983	2,549	2,999	2,991
26	37	83	160	257	74	166	319	515	756	1,056	249	479	772	1,133	1,584	2,130	638	1,029	1,511	2,112	2,839	-
	1.5/3	1.5/3	1.5/3.8	2.5/6.2	1.5/3	1.5/3	1.5/3.8	2.5/6.2	3.6/9.1	4.7/11.7	1.5/3	1.5/3.8	2.5/6.2	3.6/9.1	4.7/11.7	5.5/13.8	1.5/3.8	2.5/6.2	3.6/9.1	4.7/11.7	5.5/13.8	5.5/13.8
27	39	90	177	289	78	180	354	577	854	1,149	270	531	866	1,280	1,723	2,105	708	1,155	1,707	2,297	2,807	2,839
	32	71	137	222	64	142	275	444	652	913	214	412	666	979	1,370	1,845	549	887	1,305	1,827	2,460	-
28	1.5/3	1.5/3	1.5/3.5	2.3/5.6	1.5/3	1.5/3	1.5/3.5	2.3/5.6	3.3/8.3	4.4/11.1	1.5/3	1.5/3.5	2.3/5.6	3.3/8.3	4.4/11.1	5.4/13.6	1.5/3.5	2.3/5.6	3.3/8.3	4.4/11.1	5.4/13.6	5.5/13.8
	67	132	217	357	134	265	434	645	909	1,200	397	651	967	1,364	1,735	2,105	529	868	1,289	1,819	2,313	2,576
29	54	104	168	257	83	187	346	546	816	1,116	211	412	646	946	1,246	1,616	415	672	991	1,392	1,880	-
	1.5/3	1.5/3	1.9/4.7	3.1/7.7	1.5/3	1.5/3	1.9/4.7	3.1/7.7	4.2/10.5	5.2/13.1	1.5/3	1.5/3	1.9/4.7	3.1/7.7	4.2/10.5	5.5/13.8	1.5/3	1.9/4.7	3.1/7.7	4.2/10.5	5.5/13.8	5.5/13.8
30	51	101	167	257	83	187	346	546	816	1,116	211	412	646	946	1,246	1,616	415	672	991	1,392	1,880	-
	42	80	130	217	83	161	261	385	542	752	241	391	578	813	1,100	1,415	321	521	770	1,083	1,467	-
31	1.5/3	1.5/3	1.6/4	2.5/6.2	1.5/3	1.5/3	1.6/4	2.5/6.2	3.3/8.3	4.4/11.1	1.5/3	1.5/3	1.6/4	2.5/6.2	3.3/8.3	4.5/11.2	1.5/3	1.6/4	2.5/6.2	3.3/8.3	4.5/11.2	5.5/13.8
	39	79	130	217	83	161	261	385	542	752	241	391	578	813	1,100	1,415	321	521	770	1,083	1,467	-
32	33	63	103																			

# Versa-Lam LVL Beam Allowable Nailing

## Closest Allowable Nail Spacing

Nail Size	Nailing Parallel to Glue Lines (Narrow Face) <sup>(1)</sup>						Nailing Perpendicular to Glue Lines (Wide Face)	
	Versa-Lam <sup>®</sup> LVL						All Versa-Lam <sup>®</sup> LVL Products	
	1½"		1¾"		3½" and wider		O.C.	End
	O.C.	End	O.C.	End	O.C.	End	O.C.	End
8d Box (0.113"ø x 2.5")	3"	1½"	2"	1"	2"	½"	2"	1"
8d Common (0.131"ø x 2.5")	3"	2"	3"	2"	2"	1"	2"	1"
10d and 12d Box (0.128"ø x 3", 3.25")	3"	2"	3"	2"	2"	1"	2"	1"
16d Box (0.135"ø x 3.5")	3"/5"	2"/2½"	3"/5"	2"/2½"	2"/3"	1"/2½"	2"	2"
10d and 12d Common and 16d Sinker (0.148"ø x 3", 3.25")	4"/6"	3"	4"/6"	3"	2"/4"	2"/3"	2"	2"
16d Common (0.162"ø x 3.5")	6"/8"	4"	6"/8"	3"/4"	2"/4"	2"/3"	2"/3"	2"/2½"

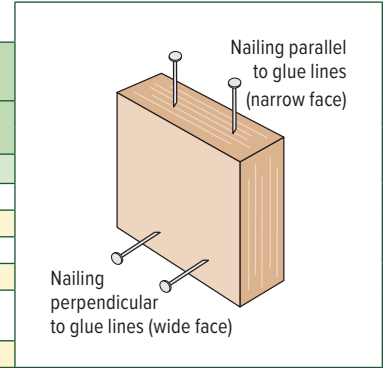

Red numbers indicate different nail spacing for Versa-Lam<sup>®</sup> LVL manufactured in Thorsby, AL.

(1) For 1¾" thickness and greater, two rows of nails (such as for a metal strap) are allowed (use ½" minimum offset between rows and stagger nails).

► Offset and stagger nail rows from floor sheathing and wall sole plate.

► Simpson Strong-Tie A35 and LPT4 connectors may be attached to the side of Versa-Lam<sup>®</sup> LVL. Use nails as specified by Simpson Strong-Tie.

## Versa-Lam LVL Beam Design Values

Grade	Width	Depth	Weight (lb/ft)	Allowable Shear (lb)	Allowable Moment (ft-lb)	Moment of Inertia (in <sup>4</sup> )
Versa-Stud <sup>®</sup> 1.8E 2650	1½"	3½"	1.5	998	776	5.4
		5½"	2.4	1,568	1,821	20.8
		7¼"	3.2	2,066	3,069	47.6
Versa-Lam <sup>®</sup> LVL 2.1E 3100	1¾"	3½"	1.8	1,164	1,058	6.3
		5½"	2.8	1,829	2,486	24.3
		7¼"	3.7	2,411	4,189	55.6
		9¼"	4.7	3,076	6,636	115.4
		9½"	4.8	3,159	6,979	125.0
		11¼"	5.7	3,741	9,605	207.6
		11⅞"	6.0	3,948	10,638	244.2
		14"	7.1	4,655	14,517	400.2
	3½"	16"	8.1	5,320	18,682	597.3
		18"	9.1	5,985	23,337	850.5
		24"	12.2	7,980	40,183	2,016.0
		5½"	5.6	3,658	4,971	48.5
		7¼"	7.4	4,821	8,377	111.1
		9¼"	9.4	6,151	13,272	230.8
9½"		9.6	6,318	13,958	250.1	
11¼"		11.4	7,481	19,210	415.3	
11⅞"		12.1	7,897	21,275	488.4	
14"		14.2	9,310	29,035	800.3	

Grade	Width	Depth	Weight (lb/ft)	Allowable Shear (lb)	Allowable Moment (ft-lb)	Moment of Inertia (in <sup>4</sup> )	
Versa-Lam <sup>®</sup> LVL 2.1E 3100	5¼"	5¼"	8.0	5,237	6,830	63.3	
		5½"	8.4	5,486	7,457	72.8	
		7¼"	11.0	7,232	12,566	166.7	
		9¼"	14.1	9,227	19,908	346.3	
		9½"	14.5	9,476	20,937	375.1	
		11¼"	17.1	11,222	28,814	622.9	
		11⅞"	18.1	11,845	31,913	732.6	
		14"	21.3	13,965	43,552	1,200.5	
		16"	24.4	15,960	56,046	1,792.0	
		18"	27.4	17,955	70,011	2,551.5	
		20"	30.4	19,950	85,428	3,500.0	
		24"	36.5	23,940	120,549	6,048.0	
		7"	9¼"	16.6	12,303	26,544	461.7
			9½"	17.1	12,635	27,916	500.1
	11¼"		20.2	14,963	38,419	830.6	
	11⅞"		21.4	15,794	42,550	976.8	
	14"		25.2	18,620	58,069	1,600.7	
	16"		28.8	21,280	74,728	2,389.3	
	18"		32.4	23,940	93,348	3,402.0	
	20"		36.0	26,600	113,904	4,666.7	
	24"		43.2	31,920	160,732	8,064.0	

## Versa-Lam LVL Beam Allowable Stress Values

Design Property	Grade	Modulus of Elasticity True (Shear-Free) E (x 10 <sup>6</sup> psi) <sup>(1)(7)</sup>	Modulus of Elasticity Apparent E (x 10 <sup>6</sup> psi) <sup>(1)</sup>	Modulus of Elasticity for Stability E <sub>min</sub> (x 10 <sup>6</sup> psi) <sup>(1)(8)</sup>	Bending F <sub>b</sub> (psi) <sup>(2)(3)</sup>	Horizontal Shear F <sub>v</sub> (psi) <sup>(2)(4)</sup>	Tension Parallel to Grain F <sub>t</sub> (psi) <sup>(2)(5)</sup>	Compression Parallel to Grain F <sub>c  </sub> (psi) <sup>(2)</sup>	Compression Perpendicular to Grain F <sub>c⊥</sub> (psi) <sup>(1)(6)</sup>	Equivalent Specific Gravity for Fastener Design (SG)
Versa-Lam <sup>®</sup> LVL Beams	2.1E 3100	2.1	2.0	1.1	3,100	285	2,150	3,000	750	0.5
Versa-Lam <sup>®</sup> LVL Studs	1.8E 2650	1.8	1.7	0.9	2,650	285	1,650	3,000	750	0.5
Versa-Lam <sup>®</sup> LVL Columns	1.8E 2650	1.8	1.7	0.9	2,650	285	1,650	3,000	750	0.5

### NOTES

(1) Value cannot be adjusted for load duration.

(2) Value is based on 100% load duration and may be adjusted for other load durations.

(3) Fiber stress bending value shall be multiplied by the depth factor, (12/d)<sup>1/9</sup> where d = member depth [in].

(4) Stress applied perpendicular to the glue lines.

(5) Tension value shall be multiplied by a length factor, (4/L)<sup>1/8</sup> where

L = member length [ft]. Use L = 4 for members less than four feet long.

(6) Stress applied parallel to the glue lines.

(7) True or shear-free modulus of elasticity does not account for shear deformation.

(8) E<sub>min</sub> is the reference modulus of elasticity for beam and column stability calculations. It is calculated using E<sub>apparent</sub> in accordance with Appendix D of the 2018 NDS. When calculating E<sub>min</sub>, the coefficient of modulus of elasticity, COV<sub>E</sub>, may be taken as 0.10, and the adjustment factor to convert E to a pure bending basis may be taken as 1.05.

► Design properties are limited to dry conditions of use where the maximum moisture content of the material will not exceed 16%.

# Versa-Lam LVL 1.8E 2650 Columns

## Allowable Axial Load (lb)

Column Length	3½" x 3½"			3½" x 4¾"			3½" x 5¼"			3½" x 5½"			3½" x 7"		
	100%	115%	125%	100%	115%	125%	100%	115%	125%	100%	115%	125%	100%	115%	125%
4'	14,700	16,090	16,930	18,390	20,130	21,180	22,070	24,165	25,430	23,130	25,320	26,640	29,450	32,240	33,920
5'	12,270	13,150	13,660	15,350	16,440	17,090	18,425	19,740	20,515	19,300	20,680	21,490	24,580	26,330	27,365
6'	10,080	10,650	10,980	12,610	13,320	13,740	15,140	15,995	16,495	15,860	16,750	17,280	20,195	21,335	22,000
7'	8,310	8,705	8,930	10,400	10,890	11,170	12,480	13,075	13,415	13,080	13,700	14,050	16,650	17,435	17,890
8'	6,930	7,205	7,370	8,660	9,010	9,210	10,405	10,825	11,070	10,900	11,340	11,600	13,880	14,440	14,760
9'	5,840	6,050	6,160	7,300	7,560	7,710	8,770	9,080	9,260	9,190	9,510	9,700	11,700	12,115	12,350
10'	4,980	5,135	5,225	6,230	6,420	6,540	7,480	7,715	7,850	7,830	8,080	8,220	9,975	10,290	10,470
11'	4,290	4,410	4,480	5,360	5,520	5,600	6,445	6,625	6,730	6,750	6,940	7,050	8,595	8,835	8,975
12'	3,730	3,825	3,880	4,660	4,780	4,850	5,600	5,745	5,830	5,870	6,020	6,100	7,475	7,665	7,775
13'	3,270	3,350	3,390	4,090	4,190	4,240	4,915	5,030	5,095	5,150	5,270	5,340	6,555	6,710	6,795
14'	2,890	2,950	2,990	3,610	3,690	3,740	4,340	4,435	4,490	4,550	4,650	4,700	5,790	5,915	5,990
Column Length	3½" x 7¼"			5¼" x 5¼"			5¼" x 5½"			5¼" x 7"			5¼" x 7¼"		
	100%	115%	125%	100%	115%	125%	100%	115%	125%	100%	115%	125%	100%	115%	125%
4'	30,500	33,390	35,130												
5'	25,460	27,270	28,340												
6'	20,910	22,090	22,780	33,070	36,220	38,110	34,670	37,950	39,930						
7'	17,250	18,060	18,530	29,420	31,730	33,085	30,830	33,240	34,660						
8'	14,370	14,960	15,290	25,875	27,570	28,565	27,110	28,880	29,930	34,525	36,790	38,115	35,760	38,090	39,480
9'	12,120	12,540	12,790	22,690	23,970	24,715	23,770	25,110	25,900	30,275	31,985	32,980	31,360	33,130	34,160
10'	10,330	10,660	10,840	19,930	20,920	21,495	20,880	21,920	22,520	26,600	27,920	28,685	27,550	28,920	29,710
11'	8,900	9,150	9,300	17,585	18,375	18,820	18,420	19,250	19,720	23,465	24,510	25,125	24,310	25,400	26,010
12'	7,740	7,940	8,050	15,590	16,220	16,585	16,340	16,990	17,380	20,805	21,650	22,130	21,550	22,420	22,930
13'	6,790	6,950	7,040	13,895	14,410	14,700	14,560	15,100	15,400	18,545	19,225	19,620	19,210	19,920	20,320
14'	6,000	6,130	6,200	12,450	12,870	13,115	13,040	13,480	13,740	16,615	17,180	17,500	17,210	17,790	18,130
15'				11,210	11,560	11,760	11,740	12,110	12,320	14,960	15,425	15,695	15,490	15,980	16,260
16'				10,135	10,430	10,600	10,620	10,930	11,110	13,525	13,920	14,150	14,010	14,420	14,650
17'				9,205	9,455	9,600	9,650	9,910	10,060	12,285	12,620	12,810	12,730	13,070	13,270
18'				8,395	8,610	8,735	8,800	9,020	9,150	11,205	11,495	11,655	11,610	11,900	12,070
19'				7,685	7,870	7,975	8,050	8,250	8,360	10,260	10,505	10,645	10,620	10,880	11,030
20'				7,060	7,220	7,310	7,400	7,560	7,660	9,420	9,635	9,760	9,760	9,980	10,110
21'				6,505	6,645	6,725	6,820	6,960	7,050	8,680	8,870	8,980	8,990	9,190	9,300

### NOTES

- ▶ Table assumes that the column is braced at column ends only. Effective column length is equal to actual column length.
- ▶ Allowable loads are based upon one-piece (solid) column members used in dry service conditions. BC Calc® software may be used for multi-piece column design.
- ▶ Allowable loads are based on an eccentricity value equal to 0.167 multiplied by either the column thickness or width (worst case).
- ▶ Allowable loads are based on axially loaded columns using the design provisions of the 2018 *National Design Specification (NDS) for Wood Construction*. Table capacity values based upon a buckling length coefficient, ( $K_e$ ) equal to 1.0 (rotation free, translation fixed at each column end per NDS Appendix G). A  $K_e$  coefficient of 1.0 conservatively models typical wood column applications. For other end fixity conditions, contact Boise Cascade EWP Engineering. For side or other combined bending and axial loads, see provisions in 2018 NDS.
- ▶ Load values are not shown for short lengths due to loads exceeding common connector capacities. Load values are not shown for longer lengths if the controlling slenderness ratio exceeds 50 (per NDS).
- ▶ Lateral loads (wind loading) are not considered in this table. BC Calc® software may be used for out-of-plane lateral load column application design.

# Versa-Stud LVL 1.8E 2650

## Reference Design Values

Product	Bending $F_b$ (psi)	Compression Parallel to Grain $F_{c  }$ (psi)	Compression Perp to Grain $F_{c\perp}$ (psi)	Modulus of Elasticity – Apparent $E$ (psi)	Horizontal Shear $F_v$ (psi)
Versa-Stud® 1.8E 2650 1½" x 5½"	2,865	3,000	610	1,700,000	285
Spruce Pine Fir (North) # 1 / 2 Grade 2 x 6	1,138	1,150	425	1,400,000	135
Hem-Fir # 2 Grade 2 x 6	1,105	1,300	405	1,300,000	150
Western Woods # 2 Grade 2 x 6	878	900	335	1,000,000	135

### NOTES

- ▶ Design values are for loads applied to the narrow face of the studs.
- ▶ Dimension lumber values per *NDS Supplement, Design Values for Wood Construction*, 2018 Edition.
- ▶ Repetitive member factors have not been applied to the bending values. Depth (size) factors per ICC-ES®/APA® ESR-1040 and 2018 NDS have been applied to the corresponding bending values.

For additional design information, please see the *Versa-Stud Eastern Tall Wall Guide*.

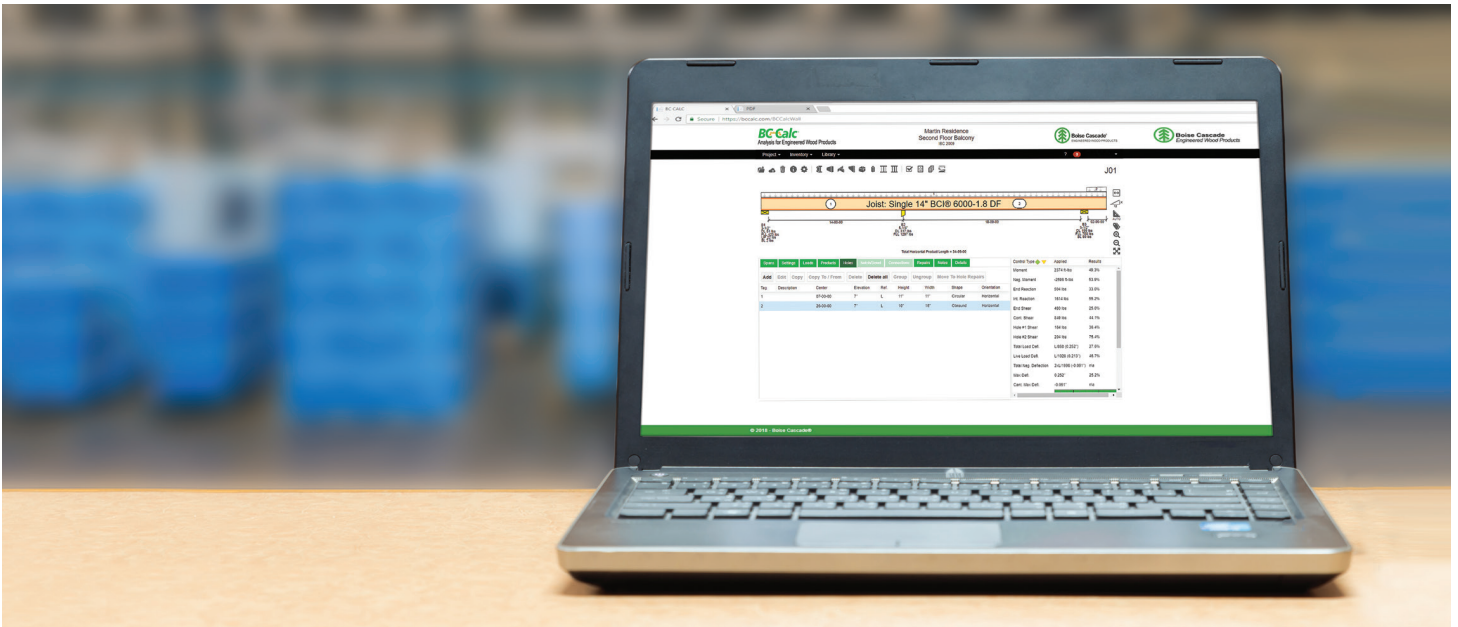

# INTEGRATED SOFTWARE FOR EASY SPECIFICATION

All Boise Cascade's engineered wood products are incorporated into Boise Cascade's software suite. BC Framer®, BC Connect®, BC Calc®, and SawTek® all work together, seamlessly integrating design and processing technology into one automated system.

## SOFTWARE BENEFITS

- ▶ Design member by member in BC Calc, or create a complete 3D model in BC Framer
- ▶ Dealers can manage projects and material lists and optimize manual or automated saw cut patterns in BC Connect
- ▶ SawTek's processing software cuts, drills, and labels job packs according to your specifications

With Boise Cascade's software suite, there's no need to worry about missing pieces or manual entry errors. The software applications share data digitally, ensuring nothing gets lost or mistyped.

Boise Cascade's software suite is available at [www.bc.com/ewp/software/](http://www.bc.com/ewp/software/)

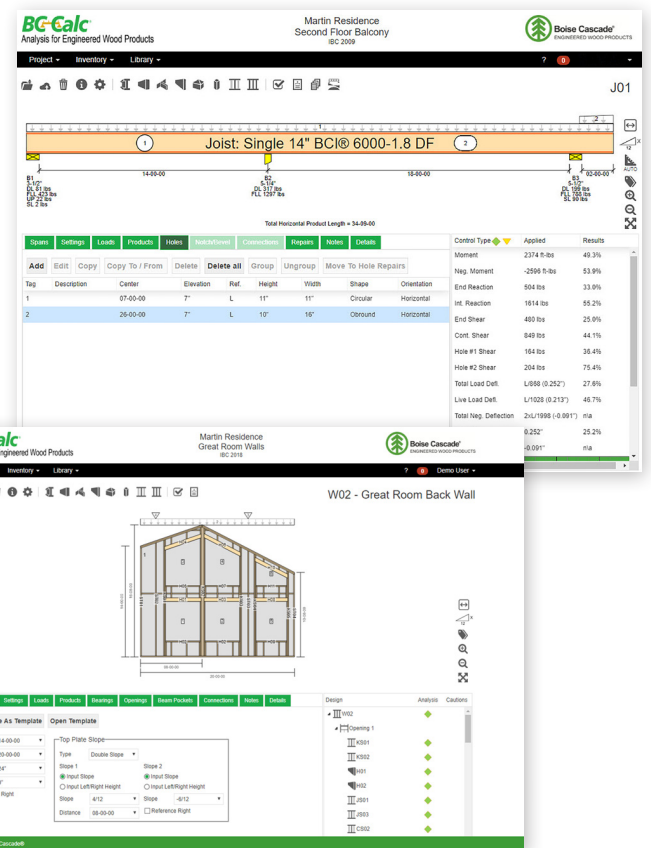

# Framing Connectors: Simpson Strong-Tie

## Single Joist – Top Flange



## Single Joist – Face Mount

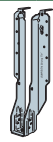

## Face Mount Skewed 45° Joist Hanger

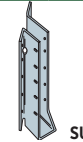

Joist Depth	BCI® Series	Hanger	Capacity (lbs)	Nailing		Joist Depth	BCI® Series	Hanger	Capacity (lbs)	Nailing		Joist Depth	BCI® Series	Hanger	Capacity (lbs)	Nailing	
				Header	Joist					Header	Joist					Header	Joist
9 1/2"	4500s	ITS1.81/9.5	993	6-10d	–	9 1/2"	4500s	IUS1.81/9.5	950	8-10d	–	9 1/2"	4500s	SUR/L1.81/9	1,081	12-16d	2-10dx1 1/2"
	5000s	ITS2.06/9.5	993	6-10d	–		5000s	IUS2.06/9.5	950	8-10d	–		5000s	SUR/L2.06/9	1,097	14-16d	2-10dx1 1/2"
	6000s	ITS2.37/9.5	1,225	6-10d	–		6000s	IUS2.37/9.5	950	8-10d	–		6000s	SUR/L2.37/9	1,343	14-16d	2-10dx1 1/2"
	6500s	ITS2.56/9.5	1,225	6-10d	–		6500s	IUS2.56/9.5	950	8-10d	–		6500s	SUR/L2.56/9	1,343	14-16d	2-10dx1 1/2"
11 7/8"	4500s	ITS1.81/11.88	1,068	6-10d	–	11 7/8"	4500s	IUS1.81/11.88	1,185	10-10d	–	11 7/8"	4500s	SUR/L1.81/11	1,306	16-16d	2-10dx1 1/2"
	5000s	ITS2.06/11.88	1,068	6-10d	–		5000s	IUS2.06/11.88	1,185	10-10d	–		5000s	SUR/L2.06/11	1,350	16-16d	2-10dx1 1/2"
	6000s	ITS2.37/11.88	1,237	6-10d	–		6000s	IUS2.37/11.88	1,185	10-10d	–		6000s	SUR/L2.37/11	1,385	16-16d	2-10dx1 1/2"
	6500s	ITS2.56/11.88	1,237	6-10d	–		6500s	IUS2.56/11.88	1,185	10-10d	–		6500s	SUR/L2.56/11	1,385	16-16d	2-10dx1 1/2"
14"	60s	ITS2.37/11.88	1,237	6-10d	–	14"	60s	IUS2.37/11.88	1,185	10-10d	–	14"	60s	SUR/L2.37/11	1,385	16-16d	2-10dx1 1/2"
	90s	ITS3.56/11.88	1,518	6-10d	–		90s	IUS3.56/11.88	1,420	12-10d	–		90s	<b>SUR/L410</b>	1,906	14-16d	2-10dx1 1/2"
	4500s	ITS1.81/14	1,075	6-10d	–		4500s	IUS1.81/14	1,420	12-10d	–		4500s	SUR/L1.81/14	1,675	20-16d	2-10dx1 1/2"
	5000s	ITS2.06/14	1,081	6-10d	–		5000s	IUS2.06/14	1,420	12-10d	–		5000s	SUR/L2.06/14	1,693	18-16d	2-10dx1 1/2"
16"	6000s	ITS2.37/14	1,262	6-10d	–	16"	6000s	IUS2.37/14	1,420	12-10d	–	16"	6000s	SUR/L2.37/14	1,693	18-16d	2-10dx1 1/2"
	6500s	ITS2.56/14	1,262	6-10d	–		6500s	IUS2.56/14	1,420	12-10d	–		6500s	SUR/L2.56/14	1,693	18-16d	2-10dx1 1/2"
	60s	ITS2.37/14	1,262	6-10d	–		60s	IUS2.37/14	1,420	12-10d	–		60s	SUR/L2.37/14	1,693	18-16d	2-10dx1 1/2"
	90s	ITS3.56/14	1,520	6-10d	–		90s	IUS3.56/14	1,420	12-10d	–		90s	<b>SUR/L414</b>	2,050	18-16d	2-10dx1 1/2"
16"	4500s	ITS1.81/16	1,081	6-10d	–	16"	4500s	IUS1.81/16	1,660	14-10d	–	16"	4500s	<b>SUR/L1.81/14</b>	1,887	20-16d	2-10dx1 1/2"
	5000s	ITS2.06/16	1,087	6-10d	–		5000s	IUS2.06/16	1,660	14-10d	–		5000s	<b>SUR/L2.06/11</b>	1,920	18-16d	2-10dx1 1/2"
	6000s	ITS2.37/16	1,268	6-10d	–		6000s	IUS2.37/16	1,660	14-10d	–		6000s	<b>SUR/L2.37/14</b>	1,920	18-16d	2-10dx1 1/2"
	6500s	ITS2.56/16	1,268	6-10d	–		6500s	IUS2.56/16	1,660	14-10d	–		6500s	<b>SUR/L2.56/14</b>	1,920	18-16d	2-10dx1 1/2"
16"	60s	ITS2.37/16	1,268	6-10d	–	16"	60s	IUS2.37/16	1,660	14-10d	–	16"	60s	<b>SUR/L2.37/14</b>	1,920	18-16d	2-10dx1 1/2"
	90s	ITS3.56/16	1,520	6-10d	–		90s	IUS3.56/16	1,425	14-10d	–		90s	<b>SUR/L414</b>	2,250	18-16d	2-10dx1 1/2"

## Double Joist – Top Flange

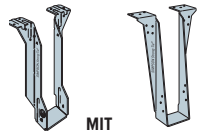

## Double Joist – Face Mount

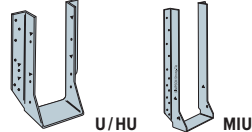

## Field Slope and Skew Joist Hanger



Joist Depth	BCI® Series	Hanger	Capacity (lbs)	Nailing		Joist Depth	BCI® Series	Hanger	Capacity (lbs)	Nailing		Joist Depth	BCI® Series	Hanger	Capacity (lbs)	Nailing	
				Header	Joist					Header	Joist					Header	Joist
9 1/2"	4500s	<b>MIT49.5</b>	2,305	8-16d	2-10dx1 1/2"	9 1/2"	4500s	<b>MIU3.56/9</b>	2,305	16-16d	2-10dx1 1/2"	9 1/2"	4500s	<b>LSSR1.81Z</b>	1,205	13-0.148 x 2 1/2"	9-0.148 x 1 1/2"
	5000s	<b>MIT4.12/9.5</b>	2,305	8-16d	2-10dx1 1/2"		5000s	<b>MIU4.12/9</b>	2,305	16-16d	2-10dx1 1/2"		5000s	<b>LSSR2.12Z</b>	1,205	13-0.148 x 2 1/2"	9-0.148 x 1 1/2"
	6000s	<b>MIT359.5-2</b>	2,305	8-16d	2-10dx1 1/2"		6000s	<b>MIU4.75/9</b>	2,305	16-16d	2-10dx1 1/2"		6000s	<b>LSSR2.37Z</b>	1,205	13-0.148 x 2 1/2"	9-0.148 x 1 1/2"
	6500s	<b>MIT39.5-2</b>	2,305	8-16d	2-10dx1 1/2"		6500s	<b>MIU5.12/9</b>	2,305	16-16d	2-10dx1 1/2"		6500s	<b>LSSR2.56Z</b>	1,205	13-0.148 x 2 1/2"	9-0.148 x 1 1/2"
11 7/8"	4500s	<b>MIT411.88</b>	2,305	8-16d	2-10dx1 1/2"	11 7/8"	4500s	<b>MIU3.56/11</b>	2,880	20-16d	2-10dx1 1/2"	11 7/8"	4500s	<b>LSSR1.81Z</b>	1,205	13-0.148 x 2 1/2"	9-0.148 x 1 1/2"
	5000s	<b>MIT4.12/11.88</b>	2,305	8-16d	2-10dx1 1/2"		5000s	<b>MIU4.12/11</b>	2,880	20-16d	2-10dx1 1/2"		5000s	<b>LSSR2.12Z</b>	1,205	13-0.148 x 2 1/2"	9-0.148 x 1 1/2"
	6000s	<b>MIT3511.88-2</b>	2,305	8-16d	2-10dx1 1/2"		6000s	<b>MIU4.75/11</b>	2,880	20-16d	2-10dx1 1/2"		6000s	<b>LSSR2.37Z</b>	1,205	13-0.148 x 2 1/2"	9-0.148 x 1 1/2"
	6500s	<b>MIT311.88-2</b>	2,305	8-16d	2-10dx1 1/2"		6500s	<b>MIU5.12/11</b>	2,880	20-16d	2-10dx1 1/2"		6500s	<b>LSSR2.56Z</b>	1,205	13-0.148 x 2 1/2"	9-0.148 x 1 1/2"
14"	60s	MIT3511.88-2	2,305	8-16d	2-10dx1 1/2"	14"	60s	MIU4.75/11	2,600	20-16d	2-10dx1 1/2"	14"	60s	<b>LSSR2.37Z</b>	1,205	13-0.148 x 2 1/2"	9-0.148 x 1 1/2"
	90s	<b>B7.12/11.88</b>	3,800	14-16d	2-10dx1 1/2"		90s	<b>HU412-2</b>	3,275	22-16d	2-10dx1 1/2"		90s	<b>LSSR2.56Z</b>	1,205	13-0.148 x 2 1/2"	9-0.148 x 1 1/2"
	4500s	<b>MIT414</b>	2,305	8-16d	2-10dx1 1/2"		4500s	<b>MIU3.56/14</b>	3,170	22-16d	2-10dx1 1/2"		4500s	<b>LSSR410Z</b>	1,810	20-0.162 x 2 1/2"	13-0.162 x 2 1/2"
	5000s	<b>MIT4.12/14</b>	2,305	8-16d	2-10dx1 1/2"		5000s	<b>MIU4.12/14</b>	3,170	22-16d	2-10dx1 1/2"		5000s	<b>LSSR1.81Z</b>	1,205	13-0.148 x 2 1/2"	9-0.148 x 1 1/2"
16"	6000s	<b>MIT3514-2</b>	2,305	8-16d	2-10dx1 1/2"	16"	6000s	<b>MIU4.75/14</b>	3,170	22-16d	2-10dx1 1/2"	16"	6000s	<b>LSSR2.12Z</b>	1,205	13-0.148 x 2 1/2"	9-0.148 x 1 1/2"
	6500s	<b>MIT314-2</b>	2,305	8-16d	2-10dx1 1/2"		6500s	<b>MIU5.12/14</b>	3,170	22-16d	2-10dx1 1/2"		6500s	<b>LSSR2.37Z</b>	1,205	13-0.148 x 2 1/2"	9-0.148 x 1 1/2"
	60s	MIT3514-2	2,305	8-16d	2-10dx1 1/2"		60s	MIU4.75/14	2,700	22-16d	2-10dx1 1/2"		60s	<b>LSSR2.56Z</b>	1,205	13-0.148 x 2 1/2"	9-0.148 x 1 1/2"
	90s	<b>B7.12/14</b>	3,800	14-16d	2-10dx1 1/2"		90s	<b>HU414-2</b>	3,870	26-16d	2-10dx1 1/2"		90s	<b>LSSR2.37Z</b>	1,205	13-0.148 x 2 1/2"	9-0.148 x 1 1/2"
16"	4500s	<b>MIT416</b>	2,305	8-16d	2-10dx1 1/2"	16"	4500s	<b>MIU3.56/16</b>	3,455	24-16d	2-10dx1 1/2"	16"	4500s	<b>LSSR2.56Z</b>	1,205	13-0.148 x 2 1/2"	9-0.148 x 1 1/2"
	5000s	<b>LBV4.12/16</b>	2,460	10-16d	2-10dx1 1/2"		5000s	<b>MIU4.12/16</b>	3,455	24-16d	2-10dx1 1/2"		5000s	<b>LSSR2.37Z</b>	1,205	13-0.148 x 2 1/2"	9-0.148 x 1 1/2"
	6000s	<b>MIT4.75/16</b>	2,305	8-16d	2-10dx1 1/2"		6000s	<b>MIU4.75/16</b>	3,455	24-16d	2-10dx1 1/2"		6000s	<b>LSSR2.37Z</b>	1,205	13-0.148 x 2 1/2"	9-0.148 x 1 1/2"
	6500s	<b>MIT5.12/16</b>	2,305	8-16d	2-10dx1 1/2"		6500s	<b>MIU5.12/16</b>	3,455	24-16d	2-10dx1 1/2"		6500s	<b>LSSR2.56Z</b>	1,205	13-0.148 x 2 1/2"	9-0.148 x 1 1/2"
16"	60s	MIT4.75/16	2,305	8-16d	2-10dx1 1/2"	16"	60s	MIU4.75/16	2,725	24-16d	2-10dx1 1/2"	16"	60s	<b>LSSR2.37Z</b>	1,205	13-0.148 x 2 1/2"	9-0.148 x 1 1/2"
	90s	<b>B7.12/16</b>	3,800	14-16d	2-10dx1 1/2"		90s	<b>HU414-2</b>	3,780	26-16d	2-10dx1 1/2"		90s	<b>LSSR410Z</b>	1,810	20-0.162 x 2 1/2"	13-0.162 x 2 1/2"

## Adjustable Height Joist Hanger

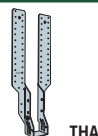

## Variable Pitch Joist Connector

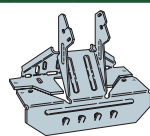

Drive 10d x 1 1/2" nails through bend tabs at a 45° angle.

Joist Depth	BCI® Series	Hanger	Capacity (lbs)	Nailing		Joist Depth	BCI® Series	Hanger	Capacity (lbs)	Fastener	
				Header	Joist					Top Plate	Rafter
9 1/2"	4500s	THAI1.81/22	1,181	6-10d	2-10dx1 1/2"	9 1/2"	4500s	LSSU125	995	9-10d	7-10dx1 1/2"
	5000s	THAI2.06/22	1,181	6-10d	2-10dx1 1/2"		5000s	LSSU2.06	995	9-10d	7-10dx1 1/2"
	6000s	THAI3522	1,393	6-10d	2-10dx1 1/2"		6000s	LSSU135	995	9-10d	7-10dx1 1/2"
	6500s	THAI322	1,393	6-10d	2-10dx1 1/2"		6500s	LSSUH310	1,425	14-10d	7-10dx1 1/2"
11 7/8"	4500s	THAI1.81/22	1,443	6-10d	2-10dx1 1/2"	11 7/8"	4500s	LSSU125	995	9-10d	7-10dx1 1/2"
	5000s	THAI2.06/22	1,443	6-10d	2-10dx1 1/2"		5000s	LSSU2.06	995	9-10d	7-10dx1 1/2"
	6000s	THAI3522	1,443	6-10d	2-10dx1 1/2"		6000s	LSSU135	995	9-10d	7-10dx1 1/2"
	6500s	THAI322	1,443	6-10d	2-10dx1 1/2"		6500s	LSSUH310	1,475	14-10d	7-10dx1 1/2"
14"	60s	THAI3522	1,443	6-10d	2-10dx1 1/2"	14"	60s	LSSU135	995	9-10d	7-10dx1 1/2"
	90s	THAI422	1,715	6-10d	2-10dx1 1/2"		90s	LSSU410	1,625	14-10d	12-10dx1 1/2"
	4500s	THAI1.81/22	1,600	6-10d	2-10dx1 1/2"		4500s	LSSU125	995	9-10d	

# Framing Connectors: MiTek Structural Connectors

## Single Joist – Top Mount

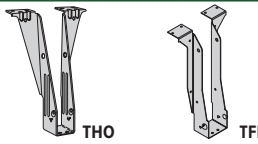

Joist Depth	BCI® Series	Hanger	Capacity [lbs]	Nailing	
				Header	Joist
9½"	4500s	THO17950	993	(6) 10d	(2) 10d x 1½"
	5000s	TFL2095	993	(6) 10d	(2) 10d x 1½"
	6000s	TFL2395	1,225	(6) 10d	(2) 10d x 1½"
11½"	6500s	THO26950	1,262	(10) 10d	(2) 10d x 1½"
	4500s	THO17118	1,068	(6) 10d	(2) 10d x 1½"
	5000s	TFL20118	1,068	(6) 10d	(2) 10d x 1½"
	6000s	TFL23118	1,237	(6) 10d	(2) 10d x 1½"
	6500s	THO26118	1,284	(10) 10d	(2) 10d x 1½"
	60s	TFL23118	1,237	(6) 10d	(2) 10d x 1½"
14"	90s	THO35118	1,589	(10) 10d	(2) 10d x 1½"
	4500s	TFL1714	1,075	(6) 10d	(2) 10d x 1½"
	5000s	TFL2014	1,081	(6) 10d	(2) 10d x 1½"
	6000s	TFL2314	1,262	(6) 10d	(2) 10d x 1½"
	6500s	THO26140	1,328	(12) 10d	(2) 10d x 1½"
	60s	TFL2314	1,262	(6) 10d	(2) 10d x 1½"
16"	90s	THO35140	1,625	(12) 10d	(2) 10d x 1½"
	4500s	TFL1716	1,081	(6) 10d	(2) 10d x 1½"
	5000s	TFL2016	1,087	(6) 10d	(2) 10d x 1½"
	6000s	TFL2316	1,268	(6) 10d	(2) 10d x 1½"
	6500s	THO26160	1,339	(12) 10d	(2) 10d x 1½"
	60s	TFL2316	1,268	(6) 10d	(2) 10d x 1½"
90s	THO35160	1,660	(12) 10d	(2) 10d x 1½"	

## Single Joist – Face Mount

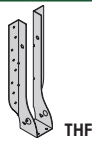

Joist Depth	BCI® Series	Hanger	Capacity [lbs]	Nailing	
				Header	Joist
9½"	4500s	IHFL17925	960	(8) 10d	–
	5000s	IHFL20925	960	(8) 10d	–
	6000s	IHFL23925	960	(8) 10d	–
11½"	6500s	THF12595	1,250	(8) 10d	–
	4500s	IHFL17112	1,187	(10) 10d	–
	5000s	IHFL20112	1,187	(10) 10d	–
	6000s	IHFL23112	1,200	(10) 10d	–
	6500s	THF125118	1,250	(10) 10d	–
	60s	IHFL23112	1,200	(10) 10d	–
14"	90s	IHFL35112	1,200	(10) 10d	–
	4500s	IHFL1714	1,200	(12) 10d	–
	5000s	IHFL2014	1,212	(12) 10d	–
	6000s	IHFL2314	1,350	(12) 10d	–
	6500s	THF2514	1,350	(14) 10d	–
	60s	IHFL2314	1,350	(12) 10d	–
16"	90s	IHFL3514	1,440	(12) 10d	–
	4500s	IHFL1716	1,212	(14) 10d	–
	5000s	IHFL2016	1,225	(14) 10d	–
	6000s	IHFL2316	1,362	(14) 10d	–
	6500s	IHF2616	1,362	(14) 10d	(2) 10d x 1½"
	60s	IHFL2316	1,362	(14) 10d	–
90s	IHFL3516	1,680	(14) 10d	–	

## Single Joist – Face Mount Skewed 45°

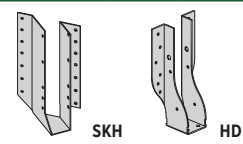

Joist Depth	BCI®	Hanger	Capacity [lbs]	Nailing	
				Header	Joist
9½"	4500s	SKH1720L/R	1,153	(14) 10d	(10) 10d x 1½"
	5000s	SKH2020L/R	1,153	(14) 10d	(10) 10d x 1½"
	6000s	SKH2320L/R	1,384	(14) 10d	(10) 10d x 1½"
11½"	6500s	SKH2520L/R	1,384	(14) 10d	(10) 10d x 1½"
	4500s	SKH1720L/R	1,434	(14) 10d	(10) 10d x 1½"
	5000s	SKH2020L/R	1,434	(14) 10d	(10) 10d x 1½"
	6000s	SKH2320L/R	1,434	(14) 10d	(10) 10d x 1½"
	6500s	SKH2520L/R	1,434	(14) 10d	(10) 10d x 1½"
	60s	SKH2320L/R	1,434	(14) 10d	(10) 10d x 1½"
14"	90s	SKH410L/R	1,900	(16) 10d	(10) 16d
	4500s	SKH1720L/R	1,562	(14) 10d	(10) 10d x 1½"
	5000s	SKH2020L/R	1,562	(14) 10d	(10) 10d x 1½"
	6000s	SKH2320L/R	1,562	(14) 10d	(10) 10d x 1½"
	6500s	SKH2520L/R	1,562	(14) 10d	(10) 10d x 1½"
	60s	SKH2320L/R	1,562	(14) 10d	(10) 10d x 1½"
16"	90s	SKH410L/R	2,050	(16) 10d	(10) 16d
	4500s	SKH1720L/R	1,635	(16) 10d	(10) 10d x 1½"
	5000s	SKH2024L/R	1,643	(16) 10d	(10) 10d x 1½"
	6000s	SKH2324L/R	1,690	(16) 10d	(10) 10d x 1½"
	6500s	SKH2524L/R	1,690	(16) 10d	(10) 10d x 1½"
	60s	SKH2324L/R	1,690	(16) 10d	(10) 10d x 1½"
90s	SKH414L/R	2,250	(22) 16d	(10) 16d	

## Double Joist – Top Mount

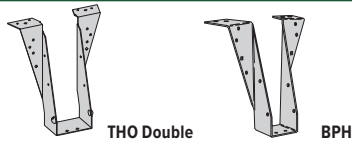

Joist Depth	BCI® Series	Hanger	Capacity [lbs]	Nailing	
				Header	Joist
9½"	4500s	THO35950	2,053	(10) 10d	(2) 10d x 1½"
	5000s	THO20950-2	2,475	(10) 16d	(6) 10d
	6000s	THO23950-2	2,825	(10) 16d	(6) 10d
	6500s	THO25950-2	2,825	(10) 16d	(6) 10d
11½"	4500s	THO35118	2,315	(10) 10d	(2) 10d x 1½"
	5000s	THO20118-2	2,920	(10) 16d	(6) 10d
	6000s	THO23118-2	2,925	(10) 16d	(6) 10d
	6500s	THO25118-2	2,925	(10) 16d	(6) 10d
	60s	THO23118-2	3,212	(10) 16d	(6) 10d
	90s	BPH71118	3,075	(10) 16d	(6) 10d
14"	4500s	THO35140	2,315	(12) 10d	(2) 10d x 1½"
	5000s	THO20140-2	3,350	(10) 16d	(6) 10d
	6000s	THO23140-2	3,350	(12) 16d	(6) 10d
	6500s	THO25140-2	3,350	(12) 16d	(6) 10d
	60s	THO23140-2	3,587	(12) 16d	(6) 10d
	90s	BPH7114	3,075	(10) 16d	(6) 10d
16"	4500s	THO35160	2,359	(12) 10d	(2) 10d x 1½"
	5000s	THO20160-2	3,377	(10) 16d	(6) 10d
	6000s	THO23160-2	3,137	(12) 16d	(6) 10d
	6500s	THO25160-2	3,137	(12) 16d	(6) 10d
	60s	THO23160-2	4,050	(12) 16d	(6) 10d
	90s	BPH7116	3,075	(10) 16d	(6) 10d

## Double Joist – Face Mount

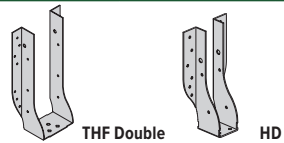

Joist Depth	BCI® Series	Hanger	Capacity [lbs]	Nailing	
				Header	Joist
9½"	4500s	IHFL35925	1,200	(10) 10d	–
	5000s	IHF20925-2	1,250	(10) 10d	(2) 10d x 1½"
	6000s	IHF23925-2	1,250	(10) 10d	(2) 10d x 1½"
11½"	6500s	THF25925-2	1,250	(10) 10d	(2) 10d x 1½"
	4500s	IHFL35112	1,200	(10) 10d	–
	5000s	IHF20112-2	1,250	(10) 10d	(2) 10d x 1½"
	6000s	THF23118-2	1,890	(16) 10d	(6) 10d
	6500s	THF25112-2	1,250	(10) 10d	(2) 10d x 1½"
	60s	THF23118-2	1,890	(16) 10d	(6) 10d
14"	90s	HD7120	2,465	(16) 16d	(6) 16d
	4500s	IHFL3514	1,440	(12) 10d	–
	5000s	IHF2014-2	1,500	(12) 10d	(2) 10d x 1½"
	6000s	THF23140-2	2,660	(20) 10d	(6) 10d
	6500s	THF25140-2	2,660	(20) 10d	(6) 10d
	60s	THF23140-2	2,660	(20) 10d	(6) 10d
16"	90s	HD7140	3,080	(20) 16d	(8) 16d
	4500s	IHFL3516	1,680	(12) 10d	–
	5000s	IHF2014-2	1,500	(12) 10d	(2) 10d x 1½"
	6000s	THF23160-2	3,175	(24) 10d	(6) 10d
	6500s	THF25160-2	3,175	(24) 10d	(6) 10d
	60s	THF23160-2	3,190	(24) 10d	(6) 10d
90s	HD7160	3,695	(24) 16d	(8) 16d	

## Single Joist – Variable Pitch Connector

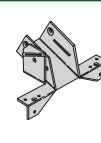

Joist Depth	BCI®	Hanger	Capacity [lbs]	Nailing	
				Header	Joist
9½"	4500s	TMP175	1,125	(6) 10d	(4) 10d x 1½"
	5000s	TMP21	1,125	(6) 10d	(4) 10d x 1½"
	6000s	TMP23	1,375	(6) 10d	(4) 10d x 1½"
11½"	6500s	TMP25	1,375	(6) 10d	(4) 10d x 1½"
	4500s	TMP175	1,425	(6) 10d	(4) 10d x 1½"
	5000s	TMP21	1,425	(6) 10d	(4) 10d x 1½"
	6000s	TMP23	1,425	(6) 10d	(4) 10d x 1½"
	6500s	TMP25	1,425	(6) 10d	(4) 10d x 1½"
	60s	TMP23	1,425	(6) 10d	(4) 10d x 1½"
14"	90s	TMP4	1,705	(6) 10d	(4) 10d x 1½"
	4500s	TMP175	1,450	(6) 10d	(4) 10d x 1½"
	5000s	TMP21	1,475	(6) 10d	(4) 10d x 1½"
	6000s	TMP23	1,525	(6) 10d	(4) 10d x 1½"
	6500s	TMP25	1,525	(6) 10d	(4) 10d x 1½"
	60s	TMP23	1,525	(6) 10d	(4) 10d x 1½"
16"	90s	TMP4	1,705	(6) 10d	(4) 10d x 1½"
	4500s	TMP175	1,450	(6) 10d	(4) 10d x 1½"
	5000s	TMP21	1,500	(6) 10d	(4) 10d x 1½"
	6000s	TMP23	1,550	(6) 10d	(4) 10d x 1½"
	6500s	TMP25	1,550	(6) 10d	(4) 10d x 1½"
	60s	TMP23	1,550	(6) 10d	(4) 10d x 1½"
90s	TMP4	1,705	(6) 10d	(4) 10d x 1½"	

## Single Joist – Adjustable Height



Joist Depth	BCI®	Hanger	Capacity [lbs]	Nailing	
				Header	Joist
9½"	4500s	MSH1722	1,143	(6) 10d	(4) 10d x 1½"
	5000s	MSH2022	1,143	(6) 10d	(4) 10d
	6000s	MSH2322	1,381	(6) 10d	(4) 10d x 1½"
	6500s	MSH322	1,381	(6) 10d	(4) 10d x 1½"
11½"	4500s	MSH1722	1,431	(6) 10d	(4) 10d x 1½"
	5000s	MSH2022	1,431	(6) 10d	(4) 10d
	6000s	MSH2322	1,431	(6) 10d	(4) 10d x 1½"
	6500s	MSH322	1,431	(6) 10d	(4) 10d x 1½"
	60s	MSH2322	1,431	(6) 10d	(4) 10d x 1½"
	90s	MSH422	1,862	(6) 10d	(6) 10d
14"	4500s	MSH1722	1,550	(6) 10d	(4) 10d x 1½"
	5000s	MSH2022	1,550	(6) 10d	(4) 10d
	6000s	MSH2322	1,550	(6) 10d	(4) 10d x 1½"
	6500s	MSH322	1,550	(6) 10d	(4) 10d x 1½"
	60s	MSH2322	1,550	(6) 10d	(4) 10d x 1½"
	90s	MSH422	1,975	(6) 10d	(6) 10d
16"	4500s	MSH1722	1,668	(6) 10d	(4) 10d x 1½"
	5000s	MSH2022	1,668	(6) 10d	(4) 10d
	6000s	MSH2322	1,668	(6) 10d	(4) 10d x 1½"
	6500s	MSH322	1,668	(6) 10d	(4) 10d x 1½"
	60s	MSH2322	1,668	(6) 10d	(4) 10d x 1½"
	90s	MSH422	2,17		

Boise Cascade is one of the largest producers of engineered wood products in North America. With coast-to-coast distribution, we strive to meet our customer's needs through regional product offerings, on-time delivery, and continued technical support long after the sale. We know our success depends upon yours. And that's why we offer a full line of innovative engineered wood products that give you the strength, stability, and consistent performance you need for each project—and every challenge.

### **BCI® Joists**

Straight and strong, yet lightweight and easy to install, our joists give you flat, stable, quiet floors and strong roofs with crisp ridge lines.

### **Boise Cascade® Rimboard**

Offered in long lengths and depths that match BCI® joists, our rim board product installs quickly and saves you time.

### **Versa-Lam® LVL Beams and Headers**

With superior strength and stability, our Versa-Lam® LVL beams are ideal for floors and roofs, and our headers make installing doors and window a snap.

### **Versa-Stud® Wall Framing**

Facing a tall wall challenge? Versa-Stud wall framing has the length, strength and wind resistance you need. It's also ideal for applications where a straight, stiff wall is critical.

### **BC Calc® Sizing Software**

Whether you're a dealer creating material lists or an architect or builder looking to quickly analyze product options, BC Calc® software makes it easy. What's more, this cloud-based application is freely available to everyone and includes a full line of technical support.

When you put it all together, Boise Cascade's Engineered Wood Products (EWP) and software tools make building strong homes easier, faster, and more profitable for home builders.

**FASTER. STRONGER. EASIER.**

### **Limited Lifetime Warranty**

All Boise Cascade BCI® joist, Versa-Lam® LVL, and AJS® joist products are covered by a limited lifetime warranty for the expected life of the structure. View the complete warranty on our website.

[bc.com/terms-conditions/sales-terms-and-conditions](https://bc.com/terms-conditions/sales-terms-and-conditions)

### **NEED MORE INFORMATION?**

Visit [bc.com/ewp](https://bc.com/ewp)  
or call 1-800-232-0788



**Boise Cascade®**  
ENGINEERED WOOD PRODUCTS

*Information provided herein was current at the time of printing but may be superseded by an updated version. Visit [bc.com/ewp](https://bc.com/ewp) to confirm that this is the most current guide.*



Patriot Contracting LLC  
 300 Shepherd Drive, Suite A  
 Houston, Texas 77007  
 United States

Fort Bend County Mustang Park  
 4521 FM 521  
 Fresno Texas. 77545

### Daily Log Weather Delays For Fort Bend County Mustang Park

Date	Ground Conditions	Wind Conditions	Sky Conditions	Calamity	Temperature	Average	Precipitation	Comments	Attachments
02/04/26	Wet/Muddy	Light Wind	Rain					Building Pads were puddled. Unable to work for majority of the day after pumping water out.	
01/26/26	Frozen	Light Wind	Ice/Sleet/Hail	Other	Very Cold			Standing water from previous days rain froze during overnight temps in the lower 20's.	
01/21/26	Wet/Muddy	Light Wind	Rain	Other	Mild		light to moderate continues	light to moderate rain continues	
01/21/26	Wet/Muddy	Light Wind	Rain	Other	Mild		light to moderate rain	light to moderate rain fall begins	
12/17/25	Wet/Muddy	Light Wind	Rain		Mild			Intermittent light rain until 3pm	
12/05/25	Wet/Muddy	Calm	Overcast		Mild			Pad work at bldg C delayed due to excessive mud	<ul style="list-style-type: none"> <li>20251205_085046.jpg</li> </ul>
12/04/25	Wet/Muddy	Light Wind	Overcast		Mild			Heavy rain this week and last night causing extremely muddy conditions at bldg pad C and A.	<ul style="list-style-type: none"> <li>20251204_071956.jpg</li> <li>20251204_083319.jpg</li> </ul>
12/03/25	Wet/Muddy	Light Wind	Rain	Other	Cold			Rains from previous day/night causing extremely muddy conditions	<ul style="list-style-type: none"> <li>20251203_073136.jpg</li> <li>20251203_073133.jpg</li> </ul>
12/02/25	Wet/Muddy		Rain	Other	Cold			Extremely muddy conditions due to rain	<ul style="list-style-type: none"> <li>20251202_074129.jpg</li> <li>20251202_083016.jpg</li> </ul>
12/01/25	Wet/Muddy	Light Wind	Rain		Cold			Rain causing extremely muddy conditions at retention pond and Bldg C pad work.	<ul style="list-style-type: none"> <li>20251201_073707.jpg</li> <li>20251201_073710.jpg</li> </ul>

















