

LOCATION MAP
NOT-TO-SCALE
MAP REF: KEY MAP 602P
ZIP CODE: 77471

STATE OF TEXAS
COUNTY OF FORT BEND

ORCHARD LAND HOLDINGS, LLC, A TEXAS LIMITED LIABILITY COMPANY AND HOLLY RIDGE DEVELOPMENT COMPANY, LLC, A TEXAS LIMITED LIABILITY COMPANY ACTING BY AND THROUGH DANIEL K. SIGNORELLI, ITS MANAGER OWNER (OR OWNERS) OF THE 28.47 ACRE TRACT DESCRIBED IN THE ABOVE AND FOREGOING MAP OF HOLLY RIDGE SECTION 9, DO HEREBY MAKE AND ESTABLISH SAID SUBDIVISION AND DEVELOPMENT PLAT OF SAID PROPERTY ACCORDING TO ALL LINES, DEDICATIONS, RESTRICTIONS AND NOTATIONS ON SAID MAPS OR PLAT AND HEREBY DEDICATE TO THE USE OF THE PUBLIC FOREVER, ALL STREETS (EXCEPT THOSE STREETS DESIGNATED AS PRIVATE STREETS), ALLEYS, PARKS, WATER COURSES, DRAINS, EASEMENTS AND PUBLIC PLACES SHOWN THEREON FOR THE PURPOSES AND CONSIDERATIONS THEREIN EXPRESSED; AND DO HEREBY BIND MYSELF (OR OURSELVES), MY (OR OUR) HEIRS AND ASSIGNS TO WARRANT AND FOREVER DEFEND THE TITLE TO THE LAND SO DEDICATED.

FURTHER, OWNERS HAVE DEDICATED AND BY THESE PRESENTS DO DEDICATE TO THE USE OF THE PUBLIC FOR PUBLIC UTILITY PURPOSES FOREVER UNOBSTRUCTED AERIAL EASEMENTS. THE AERIAL EASEMENTS SHALL EXTEND HORIZONTALLY AN ADDITIONAL ELEVEN FEET, SIX INCHES (11'6") FOR TEN FEET (10'0") PERIMETER GROUND EASEMENTS OR SEVEN FEET, SIX INCHES (7'6") FOR FOURTEEN FEET (14'0") PERIMETER GROUND EASEMENTS OR FIVE FEET, SIX INCHES (5'6") FOR SIXTEEN FEET (16'0") PERIMETER GROUND EASEMENTS, FROM A PLANE SIXTEEN FEET (16'0") ABOVE GROUND LEVEL UPWARD, LOCATED ADJACENT TO AND ADJOINING SAID PUBLIC UTILITY EASEMENTS THAT ARE DESIGNATED WITH AERIAL EASEMENTS (U.E. AND A.E.) AS INDICATED AND DEPICTED HEREON, WHEREBY THE AERIAL EASEMENT TOTALS TWENTY-ONE FEET, SIX INCHES (21'6") IN WIDTH.

FURTHER, OWNERS HAVE DEDICATED AND BY THESE PRESENTS DO DEDICATE TO THE USE OF THE PUBLIC FOR PUBLIC UTILITY PURPOSES FOREVER UNOBSTRUCTED AERIAL EASEMENTS. THE AERIAL EASEMENTS SHALL EXTEND HORIZONTALLY AN ADDITIONAL TEN FEET (10'0") FOR TEN FEET (10'0") BACK-TO-BACK GROUND EASEMENTS, OR EIGHT FEET (8'0") FOR FOURTEEN FEET (14'0") BACK-TO-BACK GROUND EASEMENTS OR SEVEN FEET (7'0") FOR SIXTEEN FEET (16'0") BACK-TO-BACK GROUND EASEMENTS, FROM A PLANE SIXTEEN FEET (16'0") ABOVE GROUND LEVEL UPWARD, LOCATED ADJACENT TO BOTH SIDES AND ADJOINING ALL PUBLIC UTILITY EASEMENTS THAT ARE DESIGNATED WITH AERIAL EASEMENTS (U.E. AND A.E.) AS INDICATED AND DEPICTED HEREON, WHEREBY THE AERIAL EASEMENT TOTALS THIRTY FEET (30'0") IN WIDTH.

FURTHER, OWNERS DO HEREBY DECLARE THAT ALL PARCELS OF LAND DESIGNATED AS LOTS ON THIS PLAT ARE INTENDED FOR THE CONSTRUCTION OF SINGLE FAMILY RESIDENTIAL DWELLING UNITS THEREON (OR THE PLACEMENT OF MOBILE HOMES) AND SHALL BE RESTRICTED FOR SAME UNDER THE TERMS AND CONDITIONS OF SUCH RESTRICTIONS FILED SEPARATELY.

FURTHER, OWNERS DO HEREBY COVENANT AND AGREE THAT ALL OF THE PROPERTY WITHIN THE BOUNDARIES OF THIS PLAT SHALL BE RESTRICTED TO PREVENT THE DRAINAGE OF ANY SEPTIC TANKS INTO ANY PUBLIC OR PRIVATE STREET, ROAD OR ALLEY OR ANY DRAINAGE DITCH, EITHER DIRECTLY OR INDIRECTLY.

FURTHER, OWNERS DO HEREBY DEDICATE TO THE PUBLIC A STRIP OF LAND TWENTY (20) FEET WIDE ON EACH SIDE OF THE CENTER LINE OF ANY AND ALL BAYOUS, CREEKS, GULLIES, RAVINES, DRAWS AND DRAINAGE DITCHES LOCATED IN SAID SUBDIVISION, AS EASEMENTS FOR DRAINAGE PURPOSES, FORT BEND COUNTY OR ANY OTHER GOVERNMENTAL AGENCY SHALL HAVE THE RIGHT TO ENTER UPON SAID EASEMENT AT ANY AND ALL TIMES FOR THE PURPOSES OF CONSTRUCTION AND MAINTENANCE OF DRAINAGE FACILITIES AND STRUCTURES.

FURTHER, OWNERS DO HEREBY COVENANT AND AGREE THAT ALL OF THE PROPERTY WITHIN THE BOUNDARIES OF THIS SUBDIVISION AND ADJACENT TO ANY DRAINAGE EASEMENT, DITCH, GULLY, CREEK OR NATURAL DRAINAGE WAY SHALL HEREBY BE RESTRICTED TO KEEP SUCH DRAINAGE WAYS AND EASEMENTS CLEAR OF FENCES, BUILDINGS, EXCESSIVE VEGETATION AND OTHER OBSTRUCTIONS TO THE OPERATIONS AND MAINTENANCE OF THE DRAINAGE FACILITY AND THAT SUCH ABUTTING PROPERTY SHALL NOT BE PERMITTED TO DRAIN DIRECTLY INTO THIS EASEMENT EXCEPT BY MEANS OF AN APPROVED DRAINAGE STRUCTURE.

FURTHER, WE DO HEREBY CERTIFY THAT WE ARE THE OWNERS OF ALL PROPERTY IMMEDIATELY ADJACENT TO THE BOUNDARIES OF THE ABOVE AND FOREGOING SUBDIVISION OF HOLLY RIDGE SECTION 9 WHERE BUILDING SETBACK LINES OR PUBLIC UTILITY EASEMENTS ARE TO BE ESTABLISHED OUTSIDE THE BOUNDARIES OF THE ABOVE AND FOREGOING SUBDIVISION AND DO HEREBY MAKE AND ESTABLISH ALL BUILDING SETBACK LINES AND DEDICATE TO THE USE OF THE PUBLIC, ALL PUBLIC UTILITY EASEMENTS SHOWN IN SAID ADJACENT ACREAGE.

FURTHER, OWNERS DO HEREBY ACKNOWLEDGE THE RECEIPT OF THE "ORDERS FOR REGULATION OF OUTDOOR LIGHTING IN THE UNINCORPORATED AREAS OF FORT BEND COUNTY, TEXAS", AND DO HEREBY COVENANT AND AGREE AND SHALL COMPLY WITH THIS ORDER AS ADOPTED BY FORT BEND COUNTY COMMISSIONERS COURT ON MARCH 23, 2004, AND ANY SUBSEQUENT AMENDMENTS.

IN TESTIMONY WHEREOF, ORCHARD LAND HOLDINGS, LLC, A TEXAS LIMITED LIABILITY COMPANY, HAS CAUSED THESE PRESENTS TO BE SIGNED BY DANIEL K. SIGNORELLI, ITS MANAGER, HEREUNTO AUTHORIZED, AND ITS COMMON SEAL HEREUNTO AFFIXED THIS _____ DAY OF _____, 2025.

ORCHARD LAND HOLDINGS, LLC,
A TEXAS LIMITED LIABILITY COMPANY

DANIEL K. SIGNORELLI
MANAGER

STATE OF TEXAS
COUNTY OF _____

BEFORE ME, THE UNDERSIGNED AUTHORITY, ON THIS DAY PERSONALLY APPEARED DANIEL K. SIGNORELLI, MANAGER, OF ORCHARD LAND HOLDINGS, LLC, A TEXAS LIMITED LIABILITY COMPANY KNOWN TO ME TO BE THE PERSONS WHOSE NAMES ARE SUBSCRIBED TO THE FOREGOING INSTRUMENT AND ACKNOWLEDGE TO ME THAT THEY EXECUTED THE SAME FOR THE PURPOSES AND CONSIDERATIONS THEREIN EXPRESSED AND IN THE CAPACITY THEREIN AND HEREIN SET OUT, AND AS THE ACT AND DEED OF SAID CORPORATION.

GIVEN UNDER MY HAND AND SEAL OF OFFICE, THIS _____ DAY OF _____, 2025.

PRINT NAME: _____
NOTARY PUBLIC IN AND FOR _____

IN TESTIMONY WHEREOF, HOLLY RIDGE DEVELOPMENT COMPANY, LLC, A TEXAS LIMITED LIABILITY COMPANY, HAS CAUSED THESE PRESENTS TO BE SIGNED BY DANIEL K. SIGNORELLI, ITS MANAGER, HEREUNTO AUTHORIZED, AND ITS COMMON SEAL HEREUNTO AFFIXED THIS _____ DAY OF _____, 2025.

HOLLY RIDGE DEVELOPMENT COMPANY, LLC,
A TEXAS LIMITED LIABILITY COMPANY

DANIEL K. SIGNORELLI
MANAGER

I, JONATHAN FRANZ, AM AUTHORIZED (OR REGISTERED) UNDER THE LAWS OF THE STATE OF TEXAS TO PRACTICE THE PROFESSION OF SURVEYING AND HEREBY CERTIFY THAT THE ABOVE SUBDIVISION IS TRUE AND ACCURATE; WAS PREPARED FROM AN ACTUAL SURVEY OF THE PROPERTY MADE UNDER MY SUPERVISION ON THE GROUND; THAT, EXCEPT AS SHOWN ALL BOUNDARY CORNERS, ANGLE POINTS, POINTS OF CURVATURE AND OTHER POINTS OF REFERENCE HAVE BEEN MARKED WITH IRON (OR OTHER OBJECTS OF A PERMANENT NATURE) PIPES OR RODS HAVING A DIAMETER OF NOT LESS THAN FIVE EIGHTHS (5/8) INCH AND A LENGTH OF NOT LESS THAN THREE (3) FEET; AND THAT THE PLAT BOUNDARY CORNERS HAVE BEEN TIED TO THE TEXAS COORDINATE SYSTEM OF 1983, SOUTH CENTRAL ZONE.

JONATHAN FRANZ
REGISTERED PROFESSIONAL LAND SURVEYOR
TEXAS REGISTRATION NO. 6705

I, BRYAN SHEPPARD, A PROFESSIONAL ENGINEER REGISTERED IN THE STATE OF TEXAS DO HEREBY CERTIFY THAT THIS PLAT MEETS ALL REQUIREMENTS OF FORT BEND COUNTY TO THE BEST OF MY KNOWLEDGE.

BRYAN SHEPPARD
REGISTERED PROFESSIONAL ENGINEER
TEXAS REGISTRATION NO. 131244

I, J. STACY SLAWNSKI, FORT BEND COUNTY ENGINEER, DO HEREBY CERTIFY THAT THE PLAT OF THIS SUBDIVISION COMPLIES WITH ALL OF THE EXISTING RULES AND REGULATIONS OF THE OFFICE AS ADOPTED BY THE FORT BEND COUNTY COMMISSIONERS' COURT. HOWEVER, NO CERTIFICATION IS HEREBY GIVEN AS TO THE EFFECT OF DRAINAGE FROM THIS SUBDIVISION ON THE INTERCEPTING DRAINAGE ARTERY OR PARENT STREAM OR ON ANY OTHER AREA OR SUBDIVISION WITHIN THE WATERSHED.

J. STACY SLAWNSKI, P. E.
FORT BEND COUNTY ENGINEER

APPROVED BY THE COMMISSIONERS' COURT OF FORT BEND COUNTY, TEXAS, THIS _____ DAY OF _____, 20____.

VINCENT M. MORALES, JR.
PRECINCT 1, COUNTY COMMISSIONER

GRADY PRESTAGE
PRECINCT 2, COUNTY COMMISSIONER

K. P. GEORGE
COUNTY JUDGE

W. A. (ANDY) MEYERS
PRECINCT 3, COUNTY COMMISSIONER

DEXTER L. MCCOY
PRECINCT 4, COUNTY COMMISSIONER

I, LAURA RICHARD, COUNTY CLERK IN AND FOR FORT BEND COUNTY, HEREBY CERTIFY THAT THE FOREGOING INSTRUMENT WITH ITS CERTIFICATE OF AUTHENTICATION WAS FILED FOR RECORDATION IN

MY OFFICE ON _____, AT _____ O'CLOCK ____M., AND IN PLAT NUMBER _____ OF THE PLAT RECORDS OF FORT BEND COUNTY, TEXAS.

WITNESS MY HAND AND SEAL OF OFFICE, AT RICHMOND, TEXAS. THE DAY AND DATE LAST ABOVE WRITTEN.

LAURA RICHARD COUNTY CLERK
FORT BEND COUNTY, TEXAS

BY: _____
DEPUTY

HOLLY RIDGE SECTION 9

A SUBDIVISION OF 28.47 ACRES SITUATED IN THE S.A. & M.G. R.R. CO. SURVEY SECTION NO. 13, ABSTRACT NO. 328 BEING A PARTIAL REPLAT OF LOTS 4 & 5 OF SLAVIN & GEORGE SUBDIVISION RECORDED IN VOLUME 64, PAGE 252, VOLUME 64, PAGE 363, AND VOLUME 64, PAGE 293 OF THE FORT BEND COUNTY DEED RECORDS.

SEPTEMBER, 2025

138 RESIDENTIAL LOTS 6 RESERVES 4 BLOCKS

ORCHARD LAND HOLDINGS, LLC,
A TEXAS LIMITED LIABILITY COMPANY
1401 WOODLANDS PKWY.
THE WOODLANDS, TEXAS 77380
TEL. 713.452.1700

HOLLY RIDGE DEVELOPMENT COMPANY LLC,
A TEXAS LIMITED LIABILITY COMPANY
1401 WOODLANDS PKWY.
THE WOODLANDS, TEXAS 77380
TEL. 713.452.1700

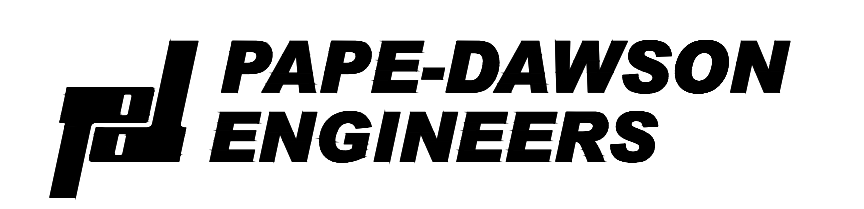

2107 CITYWEST BLVD, 3RD FLR | HOUSTON, TX 77042 | 713.428.2400
TEXAS ENGINEERING FIRM #470 | TEXAS SURVEYING FIRM #10028800

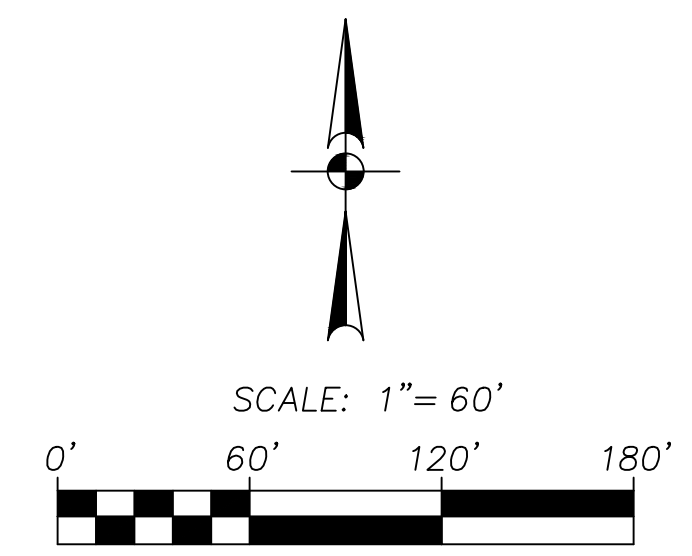
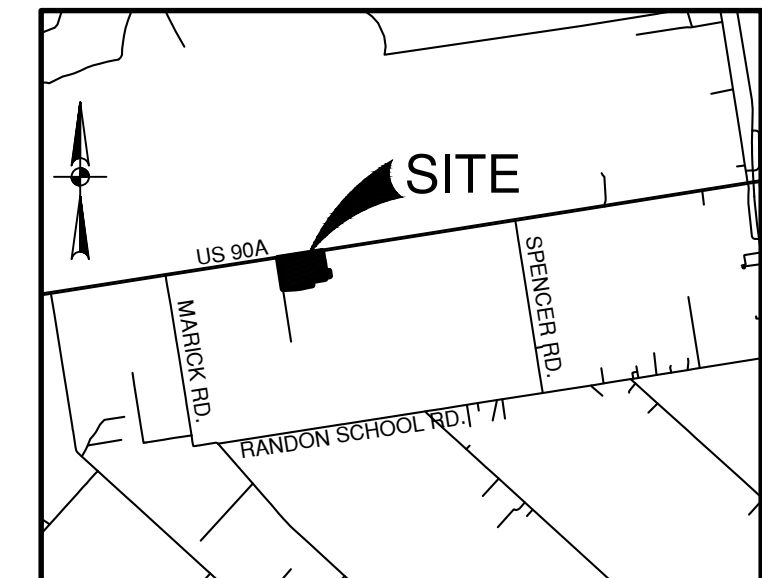

LEGEND

- FOUND 5/8" IRON ROD (UNLESS NOTED OTHERWISE)
- SET 5/8" IRON ROD (PD)
- SET 5/8" IRON ROD (PD)-ROW/LOT
- STREET NAME CHANGE
- ① = BLOCK NUMBER
- Ⓐ = RESERVE SYMBOL

LOCATION MAP

NOT-TO-SCALE
MAP REF: KEY MAP 602P
ZIP CODE: 77471

CURVE #	RADIUS	DELTA	CHORD BEARING	CHORD LENGTH
C1	1770.00'	136°45'	S79°40'55"W	49.81'
C2	25.00'	88°23'15"	S34°48'05"W	34.85'
C3	625.00'	42°49'06"	S11°35'35"W	48.00'
C4	50.00'	90°00'20"	S36°06'32"E	70.72'
C5	300.00'	89°33'08"	N54°08'35"W	422.42'
C6	1200.00'	81°11'11"	S85°30'59"W	174.10'
C7	50.00'	80°44'53"	S49°16'37"E	64.78'
C8	1700.00'	130°7'52"	N83°47'00"E	388.75'
C9	1800.00'	323°23'23"	S78°54'46"W	108.48'
C10	650.00'	42°49'06"	S11°35'35"W	49.92'
C11	30.00'	90°00'20"	N53°53'28"E	42.43'
C12	30.00'	89°59'40"	S36°06'32"E	42.42'
C13	25.00'	89°59'40"	N36°06'32"E	35.35'
C14	25.00'	90°00'20"	S53°53'28"E	35.36'
C15	25.00'	245°7'05"	S86°25'06"E	10.80'
C16	50.00'	140°31'29"	S35°47'42"W	94.12'
C17	25.00'	253°3'52"	N21°41'06"W	11.06'
C18	25.00'	90°00'32"	S36°06'32"E	35.36'
C19	25.00'	89°54'27"	S53°51'24"E	35.33'
C20	25.00'	41°39'06"	N66°17'35"E	17.78'
C21	50.00'	275°43'12"	N31°9'38"E	67.09'
C22	25.00'	54°36'38"	N66°10'05"W	22.94'
C23	25.00'	80°05'33"	S36°08'36"E	35.38'
C24	25.00'	80°44'53"	S49°16'37"E	32.39'
C25	500.00'	245°21'	N75°50'24"E	24.05'

CURVE #	RADIUS	DELTA	CHORD BEARING	CHORD LENGTH
C26	500.00'	245°21'	S75°50'24"W	24.05'
C27	25.00'	86°36'37"	N33°54'46"E	34.29'
C28	183.00'	91°31'01"	S55°09'03"E	35.82'
C29	183.00'	131°01'	S79°50'37"W	48.45'
C30	500.00'	245°21'	S78°50'45"W	24.05'
C31	500.00'	245°21'	N78°35'45"E	24.05'
C32	25.00'	93°23'23"	N66°05'14"W	36.39'
C33	675.00'	42°49'06"	S11°35'35"E	51.84'
C34	25.00'	242°54'2"	S78°03'00"W	10.58'
C35	50.00'	132°24'50"	S47°57'25"E	91.50'
C36	25.00'	270°9'10"	N44°02'25"E	11.74'
C37	25.00'	90°00'00"	S35°36'28"W	35.36'
C38	25.00'	90°00'00"	S54°23'32"E	35.36'
C39	25.00'	425°0'00"	S12°01'28"W	18.26'
C40	50.00'	275°57'49"	S75°27'34"W	66.94'
C41	25.00'	53°07'48"	N35°27'28"E	22.36'
C42	25.00'	90°00'00"	N35°36'28"E	35.36'
C43	25.00'	90°00'00"	S54°23'32"E	35.36'
C44	25.00'	119°11'18"	S12°30'09"W	43.12'
C45	50.00'	257°36'11"	N56°22'18"W	77.93'
C46	25.00'	119°11'18"	N54°25'16"E	43.12'

LINE #	BEARING	LENGTH
L1	S16°03'30"E	53.98'
L2	S7°40'21"E	80.04'
L3	S25°52'22"E	80.51'
L4	S9°23'32"E	60.00'
L5	S9°23'32"E	48.55'
L6	S76°12'22"W	50.00'
L7	S78°28'25"W	79.48'
L8	S81°05'50"W	30.00'
L9	N54°12'12"W	4.78'
L10	S07°29'26"E	5.00'
L11	N42°17'06"E	7.31'
L12	N80°36'28"E	5.00'
L13	N77°13'05"E	37.50'
L14	N74°27'44"E	79.94'
L15	N77°13'05"E	31.86'
L16	N70°09'12"E	49.41'
L17	S52°59'56"E	7.03'
L18	N36°06'22"E	7.07'
L19	S78°41'36"W	45.74'
L20	N81°06'22"E	40.00'

LINE #	BEARING	LENGTH
L21	N83°38'07"E	34.05'
L22	N80°33'41"W	37.39'
L23	N68°55'52"W	37.07'
L24	S56°23'32"E	37.09'
L25	N44°20'32"W	37.40'
L26	N27°44'32"W	37.58'
L27	S13°59'46"E	38.02'
L28	S70°34'49"E	62.96'
L29	S43°52'59"W	85.52'
L30	S88°44'04"E	40.00'
L31	S38°53'10"E	20.00'
L32	N20°06'10"E	20.00'
L33	S78°58'26"W	79.94'
L34	N77°13'05"E	25.34'

ABBREVIATION LEGEND

ESMT	EASEMENT
VOL. P.C.	VOLUME PAGE
POB	POINT OF BEGINNING
R	RADIUS
ROW	RIGHT OF WAY
FBCDR	FORT BEND COUNTY DEED RECORDS
FBCPR	FORT BEND COUNTY PLAT RECORDS
ORFBC	OFFICIAL PUBLIC RECORDS FORT BEND COUNTY
N:	NORTHING COORDINATES
E:	EASTING COORDINATES
UE	UTILITY EASEMENT
CF NO	CLERK'S FILE NUMBER
BL	BUILDING LINE
WLE	WATER LINE EASEMENT
SSE	SANITARY SEWER EASEMENT
STMSSE	STORM SEWER EASEMENT
NTS	NOT TO SCALE

HOLLY RIDGE SECTION 9

A SUBDIVISION OF 28.47 ACRES SITUATED IN THE S.A. & M.G. R.R. CO. SURVEY SECTION NO. 13, ABSTRACT NO. 328 BEING A PARTIAL REPLAT OF LOTS 4 & 5 OF SLAVIN & GEORGE SUBDIVISION RECORDED IN VOLUME 64, PAGE 252, VOLUME 64, PAGE 363, AND VOLUME 64, PAGE 293 OF THE FORT BEND COUNTY DEED RECORDS.

SEPTEMBER, 2025

138 RESIDENTIAL LOTS 6 RESERVES 4 BLOCKS

ORCHARD LAND HOLDINGS, LLC.
A TEXAS LIMITED LIABILITY COMPANY
1401 WOODLANDS PKWY.
THE WOODLANDS, TEXAS 77380
TEL. 713.452.1700



2107 CITYWEST BLVD, 3RD FLR | HOUSTON, TX 77042 | 713.428.2400
TEXAS ENGINEERING FIRM #470 | TEXAS SURVEYING FIRM #10028800
TEL. 713.452.1700

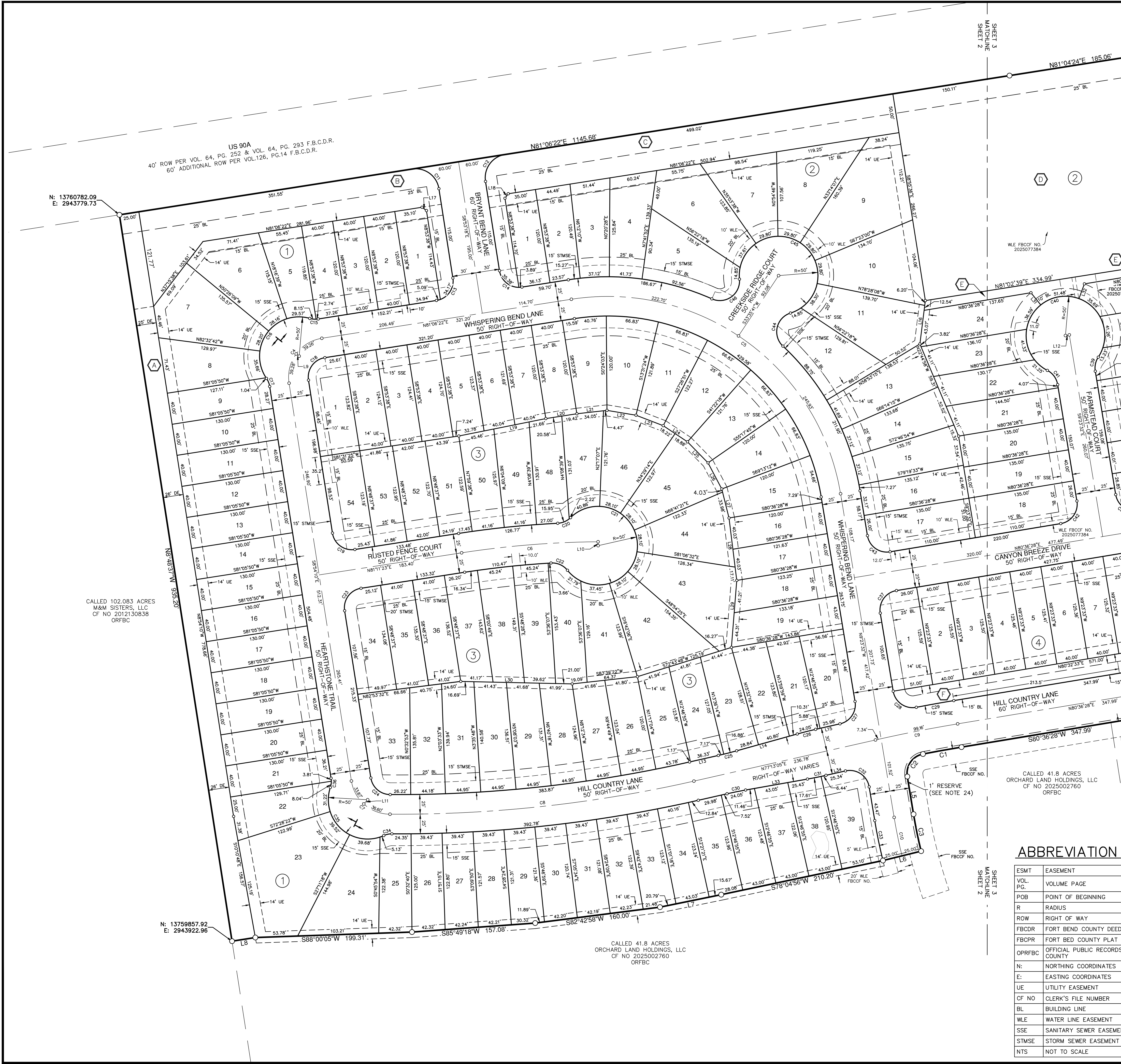

US 90A
40' ROW PER VOL. 64, PG. 252 & VOL. 64, PG. 293 F.B.C.D.R.
60' ADDITIONAL ROW PER VOL. 126, PG. 14 F.B.C.D.R.

N: 13760782.09
E: 2943773.73

CALLED 102.083 ACRES
M&M SISTERS, LLC
CF NO. 2012130838
ORFBC

N: 13759857.92
E: 2943922.96

CALLLED 41.8 ACRES
ORCHARD LAND HOLDINGS, LLC
CF NO. 2025002760
ORFBC

CALLLED 41.8 ACRES
ORCHARD LAND HOLDINGS, LLC
CF NO. 2025002760
ORFBC

SHEET 3
MAY 2025
SHEET 2

LEGEND

- FOUND 5/8" IRON ROD (UNLESS NOTED OTHERWISE)
- SET 5/8" IRON ROD (PD)
- SET 5/8" IRON ROD (PD)-ROW/LOT
- STREET NAME CHANGE
- ① BLOCK NUMBER
- Ⓐ RESERVE SYMBOL

ABBREVIATION LEGEND

ESMT	EASEMENT
VOL. PG.	VOLUME PAGE
POB	POINT OF BEGINNING
R	RADIUS
ROW	RIGHT OF WAY
FBCDR	FORT BEND COUNTY DEED RECORDS
FBCPR	FORT BEND COUNTY PLAT RECORDS
OPRFB	OFFICIAL PUBLIC RECORDS FORT BEND COUNTY
N:	NORTHING COORDINATES
E:	EASTING COORDINATES
UE	UTILITY EASEMENT
CF NO	CLERK'S FILE NUMBER
BL	BUILDING LINE
WLE	WATER LINE EASEMENT
SSE	SANITARY SEWER EASEMENT
STMSE	STORM SEWER EASEMENT
NTS	NOT TO SCALE

RESERVE TABLE

RESERVE	ACREAGE	PURPOSE	PROPOSED OWNER	MAINTENANCE
Ⓐ	0.56	LANDSCAPE/ OPEN SPACE/ DRAINAGE	FBMUD 265	FBMUD 265
Ⓑ	0.55	LANDSCAPE/ OPEN SPACE	HOA	HOA
Ⓒ	0.66	LANDSCAPE/ OPEN SPACE	HOA	HOA
Ⓓ	2.05	LANDSCAPE/ OPEN SPACE/ WATER TREATMENT PLANT	UTILITIES INVESTMENT COMPANY, INC.	UTILITIES INVESTMENT COMPANY, INC.
Ⓔ	0.10	LANDSCAPE/ OPEN SPACE	HOA	HOA
Ⓕ	0.32	LANDSCAPE/ OPEN SPACE	HOA	HOA

NOTES:

- ALL BEARINGS ARE BASED ON THE TEXAS COORDINATE SYSTEM, SOUTH CENTRAL ZONE (4204).
- THE COORDINATES SHOWN HEREON ARE TEXAS SOUTH CENTRAL ZONE NO. 4204 STATE PLANE GRID COORDINATES (NAD83) AND MAY BE BROUGHT TO SURFACE BY DIVIDING THE COMBINED SCALE FACTOR OF 0.999868660.
- WITH RESPECT TO RECORDED INSTRUMENTS WITHIN THIS PLAT, SURVEYOR RELIED ON CITY PLANNING LETTER ISSUED BY TEXAS AMERICAN TITLE COMPANY, OF NO. 2791025-05373, DATED JUNE 17, 2025.
- ELEVATIONS USED FOR DELINEATING CONTOUR LINES ARE BASED ON FORT BEND COUNTY MARKER NO. 182, PUBLISHED ELEVATION: 92.80' (NAVD 88)
- DIMENSIONS SHOWN ARE SURFACE.
- THE DRAINAGE SYSTEM FOR THIS SUBDIVISION SHALL BE DESIGNED TO MEET THE REQUIREMENTS OF THE FORT BEND COUNTY DRAINAGE CRITERIA MANUAL WHICH ALLOWS STREET PONDING DURING INTENSE RAINFALL EVENTS.
- THE TOP OF ALL FLOOR SLABS SHALL BE A MINIMUM OF 115.41 FEET ABOVE MEAN SEA LEVEL (NAVD 88 DATUM). IN ADDITION, NO TOP OF SLAB ELEVATION SHALL BE LESS THAN 24 INCHES ABOVE THE LOWEST TOP OF CURB ADJACENT TO THE LOT IN WHICH IT LIES. IN THE ABSENCE OF A CURB, THE TOP OF SLAB ELEVATION SHALL BE NO LESS THAN 24 INCHES ABOVE THE HIGHEST NATURAL GROUND ALONG THE PERIMETER OF THE BUILDING FOUNDATION AND 12 INCHES ABOVE ANY DOWN GRADIENT ROADWAY OR DRAINAGE RESTRAIN, WHICHEVER IS HIGHER.
- ALL DRAINAGE EASEMENTS TO BE KEPT CLEAR OF FENCES, BUILDINGS, VEGETATION AND OTHER OBSTRUCTIONS TO THE OPERATION AND MAINTENANCE OF THE DRAINAGE FACILITY.
- ALL PROPERTY TO DRAIN INTO THE DRAINAGE EASEMENT ONLY THROUGH APPROVED DRAINAGE STRUCTURE.
- THE SUBJECT PROPERTY IS WITHIN THE FOLLOWING FLOOD ZONE(S) AS DEPICTED ON THE FEDERAL EMERGENCY MANAGEMENT AGENCY (F.E.M.A.) FLOOD INSURANCE RATE MAP NUMBER 4815700225L, DATED APRIL 2, 2014 UNSHADED ZONE "X" FOR FORT BEND COUNTY, TEXAS AND INCORPORATED AREAS:
- THIS TRACT OF LAND IS LOCATED IN LIGHTING ZONE L3.
- THERE ARE NO KNOWN PIPELINES OR PIPELINE EASEMENTS WITHIN THE PLATTED AREA SHOWN HEREON.
- SIDEWALKS SHALL BE BUILT OR CAUSED TO BE BUILT NOT LESS THAN 5 FEET IN WIDTH ON BOTH SIDES OF ALL DEDICATED RIGHTS-OF-WAY WITHIN SAID PLAT AND ON THE CONTIGUOUS RIGHT-OF-WAY OF ALL PERIMETER ROADS SURROUNDING SAID PLAT, IN ACCORDANCE WITH A.D.A.
- A MINIMUM DISTANCE OF 10' SHALL BE MAINTAINED BETWEEN RESIDENTIAL DWELLINGS.
- FUTURE DEVELOPMENT OF EACH RESERVE MAY REQUIRE ONSITE DRAINAGE AND DETENTION FACILITIES WITHIN A DEDICATED EASEMENT TO BE MAINTAINED BY THE OWNER.
- THE MINIMUM SLAB ELEVATION LISTED ABOVE DOES NOT ACCOUNT FOR ONSITE DETENTION AND PONDING ELEVATIONS, WHICH MUST BE CHECKED AT THE TIME OF SITE PLAN DEVELOPMENT.
- SITE PLANS SHALL BE SUBMITTED TO FORT BEND COUNTY AND ANY OTHER APPLICABLE JURISDICTION FOR REVIEW AND APPROVAL TO OBTAIN A DEVELOPMENT PERMIT. DEVELOPMENT PERMITS AND ALL OTHER APPLICABLE PERMITS SHALL BE OBTAINED FROM FORT BEND COUNTY PRIOR TO BEGINNING CONSTRUCTION.
- THIS PROPERTY LIES WITHIN FORT BEND COUNTY GENERAL FUND, FORT BEND COUNTY DRAINAGE, BEASLEY FIRE, FB ESD 8, FORT BEND COUNTY MUD NO. 265, AND LAMAR CISD.
- A ONE-FOOT RESERVE DEDICATED TO THE PUBLIC IN FEE AS A BUFFER SEPARATION BETWEEN THE SIDE OR END OF STREETS IN SUBDIVISION PLATS WHERE SUCH STREETS ADJACENT ACREAGE TRACTS, THE CONDITIONS OF SUCH DEDICATION BEING THAT WHEN THE ADJACENT PROPERTY IS SUBDIVIDED BY A RECORDED PLAT, THE ONE-FOOT RESERVE SHALL THEREUPON BECOME BESTED IN THE PUBLIC FOR STREET RIGHT-OF-WAY PURPOSES AND THE FEE TITLE THEREO SHALL REVERT AND REVEST IN THE DEDICATOR, HIS HEIRS, ASSIGNS, OR SUCCESSORS.

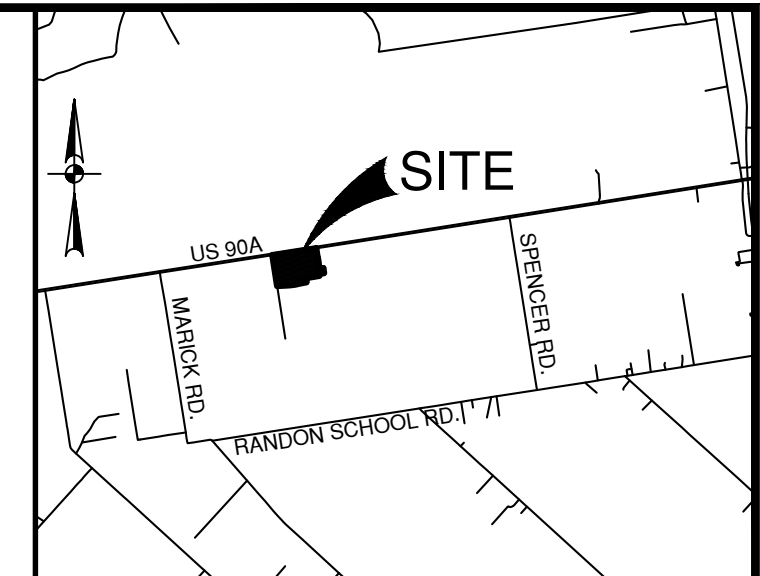
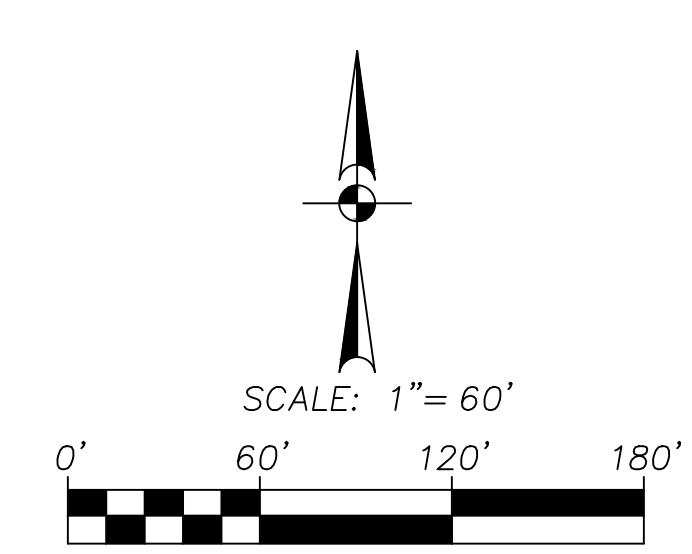
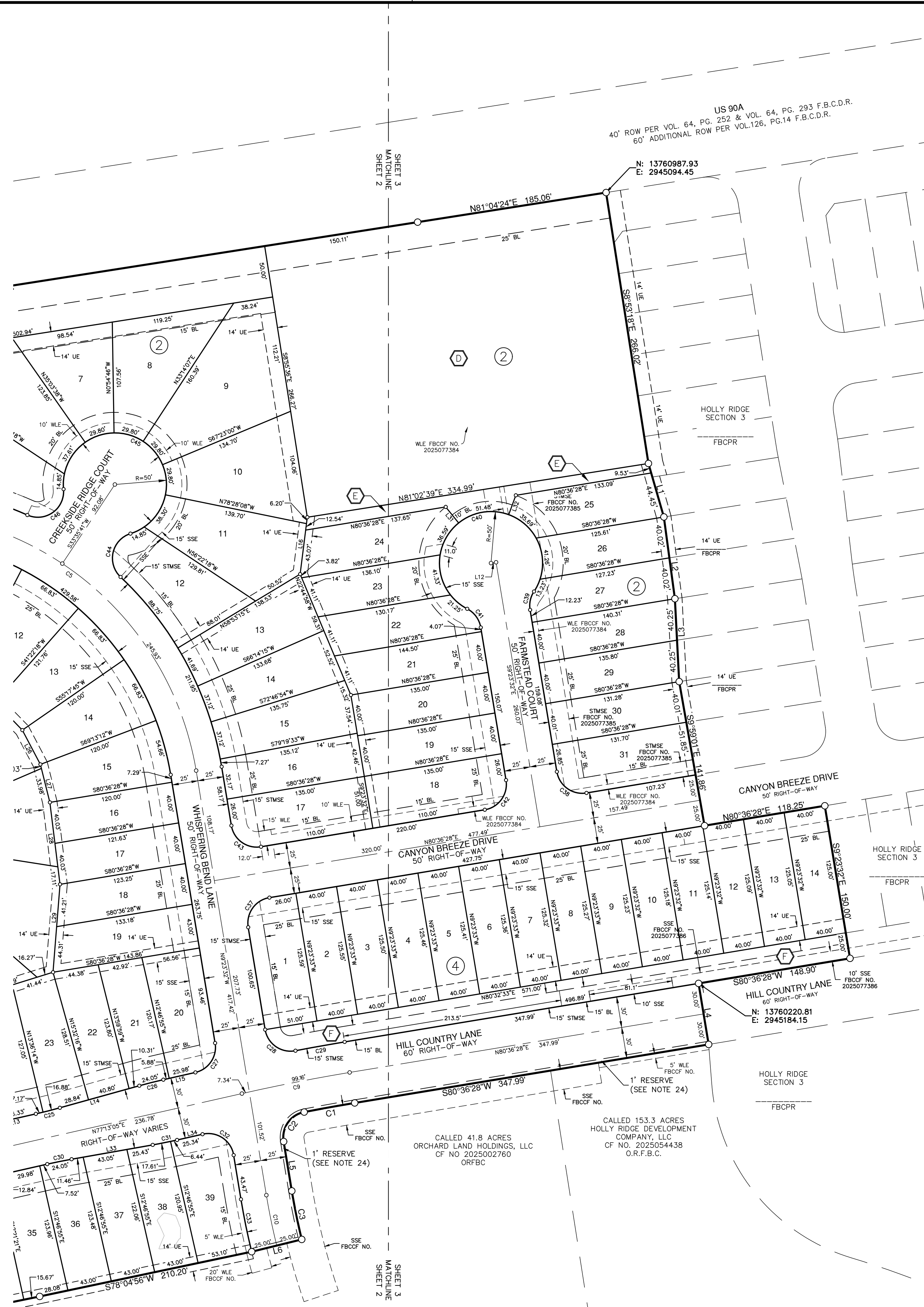

LOCATION MAP

NOT-TO-SCALE
MAP REF: KEY MAP 602P
ZIP CODE: 77471

CURVE TABLE

CURVE #	RADIUS	DELTA	CHORD BEARING	CHORD	LENGTH
C1	1770.00'	1°36'45"	S79°48'05"W	49.81'	49.82'
C2	25.00'	88°23'15"	S34°48'05"W	34.85'	38.57'
C3	625.00'	4°24'06"	S11°35'35"E	48.00'	48.01'
C4	50.00'	90°00'32"	S36°06'06"W	70.72'	78.55'
C5	300.00'	89°30'06"	N54°08'35"W	422.42'	468.63'
C6	1200.00'	8°19'11"	S85°20'59"W	174.10'	174.25'
C7	50.00'	80°44'53"	S49°16'37"E	64.78'	70.47'
C8	1700.00'	13°07'52"	N83°47'00"E	388.75'	389.60'
C9	1800.00'	3°23'23"	S78°54'46"W	106.48'	106.49'
C10	650.00'	4°24'06"	S11°35'35"E	49.92'	49.93'
C11	30.00'	90°00'20"	N53°53'28"W	42.43'	47.13'
C12	30.00'	89°59'40"	S36°06'32"W	42.42'	47.12'
C13	25.00'	89°59'40"	N36°06'32"E	35.35'	39.27'
C14	25.00'	90°00'20"	S53°53'28"E	35.36'	39.27'
C15	25.00'	24°57'05"	S86°29'06"E	10.80'	10.89'
C16	50.00'	140°31'39"	S35°47'42"W	94.12'	122.63'
C17	25.00'	25°33'52"	N21°41'06"W	11.06'	11.15'
C18	25.00'	90°00'32"	S36°06'06"W	35.36'	39.27'
C19	25.00'	89°54'27"	S53°53'24"E	35.33'	39.23'
C20	25.00'	41°39'06"	N68°17'35"E	17.78'	18.17'
C21	50.00'	275°43'12"	N1°19'38"E	67.09'	340.61'
C22	25.00'	54°36'38"	N66°07'05"W	22.94'	23.83'
C23	25.00'	90°05'33"	S36°08'36"W	35.38'	39.31'
C24	25.00'	80°44'53"	S49°16'37"E	32.39'	35.23'
C25	500.00'	2°45'21"	N75°50'24"E	24.05'	24.05'

CURVE TABLE

CURVE #	RADIUS	DELTA	CHORD BEARING	CHORD	LENGTH
C26	500.00'	2°45'21"	S75°50'24"W	24.05'	24.05'
C27	25.00'	86°36'37"	N33°54'46"E	34.29'	37.79'
C28	25.00'	91°31'01"	S55°09'03"E	35.82'	39.93'
C29	1830.00'	1°31'01"	S79°50'57"W	48.45'	48.45'
C30	500.00'	2°45'21"	N78°35'45"E	24.05'	24.05'
C31	500.00'	2°45'21"	N78°35'45"E	24.05'	24.05'
C32	25.00'	93°23'23"	N56°09'14"W	36.39'	40.75'
C33	675.00'	4°24'06"	S11°35'35"E	51.84'	51.86'
C34	25.00'	24°25'42"	S78°03'00"W	10.58'	10.66'
C35	50.00'	132°24'50"	S47°57'25"E	91.50'	115.55'
C36	25.00'	27°09'10"	N44°02'25"E	11.74'	11.85'
C37	25.00'	90°00'00"	S35°36'28"W	35.36'	39.27'
C38	25.00'	90°00'00"	S54°23'32"E	35.36'	39.27'
C39	25.00'	42°50'00"	S12°01'28"W	18.26'	18.69'
C40	50.00'	275°57'40"	S75°27'34"W	66.94'	240.82'
C41	25.00'	53°07'48"	N35°57'26"W	22.36'	23.18'
C42	25.00'	90°00'00"	N35°36'28"E	35.36'	39.27'
C43	25.00'	90°00'00"	S54°23'32"E	35.36'	39.27'
C44	25.00'	119°11'18"	S12°50'09"W	43.12'	52.01'
C45	50.00'	257°36'11"	N56°22'18"W	77.93'	224.80'
C46	25.00'	119°11'18"	N54°29'16"E	43.12'	52.01'

LINE TABLE

LINE #	BEARING	LENGTH
L1	S16°03'30"E	53.98'
L2	S74°02'1"E	80.04'
L3	S2°57'22"E	80.51'
L4	S9°23'32"E	60.00'
L5	S9°23'32"E	48.55'
L6	S78°12'22"W	50.00'
L7	S78°26'25"W	79.48'
L8	S81°05'50"W	30.00'
L9	N54°12'12"W	4.78'
L10	S0°29'26"E	5.00'
L11	N42°17'06"E	7.31'
L12	N80°36'28"E	5.00'
L13	N77°13'05"E	37.50'
L14	N74°27'44"E	79.94'
L15	N77°13'05"E	31.86'
L16	N70°19'12"E	49.41'
L17	S52°59'56"E	7.03'
L18	N36°06'22"E	7.07'
L19	S78°41'36"W	45.74'
L20	N81°06'22"E	40.00'

LINE TABLE

LINE #	BEARING	LENGTH
L21	N83°38'07"E	34.05'
L22	N80°33'41"W	37.39'
L23	N68°55'52"W	37.07'
L24	S56°22'32"E	37.09'
L25	N44°20'32"W	37.40'
L26	N27°44'32"W	37.58'
L27	S13°59'46"E	38.02'
L28	S70°34'49"E	62.96'
L29	S43°25'59"W	85.52'
L30	S88°44'04"E	40.00'
L31	N58°51'15"E	20.00'
L32	N20°06'10"E	20.00'
L33	S79°58'26"W	79.94'
L34	N77°13'05"E	25.34'

HOLLY RIDGE SECTION 9

A SUBDIVISION OF 28.47 ACRES SITUATED IN THE S.A. & M.G. R.R. CO. SURVEY SECTION NO. 13, ABSTRACT NO. 328 BEING A PARTIAL REPLAT OF LOTS 4 & 5 OF SLAVIN & GEORGE SUBDIVISION RECORDED IN VOLUME 64, PAGE 252, VOLUME 64, PAGE 363, AND VOLUME 64, PAGE 293 OF THE FORT BEND COUNTY DEED RECORDS.

SEPTEMBER, 2025

138 RESIDENTIAL LOTS 6 RESERVES 4 BLOCKS

ORCHARD LAND HOLDINGS, L.L.C.
A TEXAS LIMITED LIABILITY COMPANY
1401 WOODLANDS PKWY.
THE WOODLANDS, TEXAS 77380
TEL: 713.482.1700

HOLLY RIDGE DEVELOPMENT COMPANY, L.L.C.
A TEXAS LIMITED LIABILITY COMPANY
1401 WOODLANDS PKWY.
THE WOODLANDS, TEXAS 77380
TEL: 713.482.1700

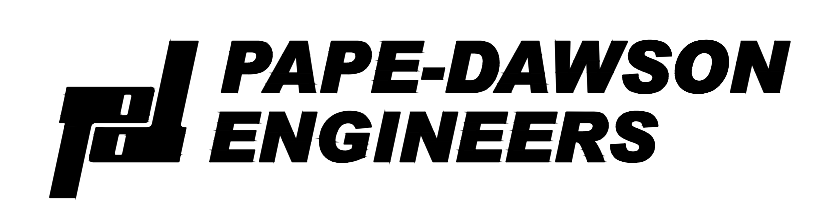

2107 CITYWEST BLVD, 3RD FLR | HOUSTON, TX 77042 | 713.428.2400
TEXAS ENGINEERING FIRM #470 | TEXAS SURVEYING FIRM #10028800

Civil Job No. 41993-40