



COUNTY ATTORNEY
Fort Bend County, Texas

BRIDGETTE SMITH-LAWSON
County Attorney

(281) 341-4555
Fax (281) 341-4557

REVIEW FORM

On September 11, 2025, the County Attorney's Office reviewed the following:

Re: 25-FAC-100919; Consent to Encroachment – CenterPoint Energy

Comments:

The above-referenced Consent to Encroachment has been reviewed and the following changes have been made:

Addition of "To the extent allowed by law" to paragraphs 2, 3, and 4 on page 2, and to paragraph 1 on page 3 for the following reasons:

- First, the County, as a governmental entity, cannot contractually waive its eminent domain authority as it is an inherent authority granted by the Texas Constitution and the statutes.
- Second, the payment of \$5,000 appears to be a penalty. Texas law requires that any contracts imposing penalties against a county must be for a measure of any damages actually incurred by the contracting party, otherwise it constitutes a gratuity in violation of article III, Sec. 52 of the Texas Constitution.
- Third, the County cannot legally indemnify or hold harmless another party for an indeterminate future liability (unless provision is made at the time of the contract by levying taxes and establishing a 2% sinking fund) as this creates a debt in violation of article III, Sec. 7 of the Texas Constitution.

A copy of the Consent to Encroachment with these changes is attached to this letter.

Should you have any questions, you may contact me at (281) 344-3930.

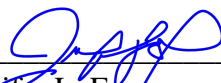

Jennifer L. Fox,
Assistant County Attorney

CONSENT TO ENCROACHMENT

NOTICE OF CONFIDENTIALITY RIGHTS: IF YOU ARE A NATURAL PERSON, YOU MAY REMOVE OR STRIKE ANY OR ALL OF THE FOLLOWING INFORMATION FROM ANY INSTRUMENT THAT TRANSFERS AN INTEREST IN REAL PROPERTY BEFORE IT IS FILED FOR RECORD IN THE PUBLIC RECORDS: YOUR SOCIAL SECURITY NUMBER OR YOUR DRIVER’S LICENSE NUMBER.

THE STATE OF TEXAS }

COUNTY OF FORT BEND }

WHEREAS, County of Fort Bend, Texas (hereinafter referred to as "Owner" whether one or more) has requested consent to encroach within an easement located within a 4.635 acre tract of land, situated in the Manuel Escalera Survey, Abstract 170, Fort Bend County, Texas, being further described in a deed to Fort Bend County, Texas, as recorded under Clerk’s File Number 2022117059 in the Official Public Records of Fort Bend County, Texas ; and also known as 1031 West Sycamore Road, Fresno, TX 77545.

WHEREAS, the above described property is subject to a 10-foot wide easement, together with its adjoining aerial easement, as recorded under County Clerk’s File 2011050348 in the Official Public Records of Fort Bend County, Texas (hereinafter referred to as “Easement Area”) created in favor of CenterPoint Energy Houston Electric, LLC, a Texas limited liability company, or the legal antecedent entity, for the erection and maintenance of communication and/or electric transmission and/or distribution lines and appurtenances (hereinafter referred to as “Facilities”) across, over, along, upon and under said property; and

WHEREAS, Owner has requested consent for the installation, construction, maintenance and/or removal of paving (hereinafter referred to as “Structure”) within said Easement Area.

NOW, THEREFORE, KNOW ALL PERSONS BY THESE PRESENTS that CenterPoint Energy Houston Electric, LLC (hereinafter referred to as “Utility” and which term also includes their affiliates, successors and assigns), hereby consents to said Structure over, across, or within said Easement Area, as illustrated on the attached certified survey labeled Exhibit “A”.

Owner, its successors, assigns, agents, and licensees, are forever subject to all the provisions stated herein.

If Owner utilizes the Easement Area for parking purposes, protective barriers shall be erected and maintained around Utility’s ground Structures as shown on Exhibit “B” attached hereto and made a part hereof, and Utility retains the right to prohibit and/or restrict parking during periods of construction or maintenance work upon its

facilities. Owner shall not place any parking sub-base material within twenty-four (24) inches of Utility's Facilities.

Owner shall observe and exercise all notification laws as per the Underground Facility Damage Prevention and Safety Act, also known as "ONE CALL" & "CALL BEFORE YOU DIG", when working in or near the Easement Area.

WHEREAS, Owner's Structure shall be installed, at its own cost and expense, as shown on said attached Exhibit "A". If at a later date any of Owner's Structure is found existing outside the locations and elevations on said attached Exhibit "A", then Owner will, at its own cost and expense, relocate this Structure to its approved location within the Easement Area to occur within ninety (90) days of any formal notice of incorrect placement. **IN THE EVENT ANY PORTION OF OWNER'S STRUCTURE ARE CONSTRUCTED OR REMAIN OUTSIDE OF THE LOCATION APPROVED BY UTILITY, OWNER, TO THE EXTENT ALLOWED BY LAW, HEREBY AGREES TO FORFEIT ANY AND ALL RIGHTS OR CAUSES OF ACTION TO CLAIM A PRESCRIPTIVE EASEMENT OR EXERCISE ADVERSE POSSESSION OR EMINENT DOMAIN, AGAINST UTILITY OR ANY PORTION OF UTILITY'S PROPERTY AND SHALL BECOME LIABLE TO PAY UTILITY THE SUM OF FIVE THOUSAND DOLLARS (\$5,000.00). AFTER BEING INVOICED BY UTILITY IN SUCH INSTANCE, SHOULD OWNER FAIL TO PAY UTILITY SUCH SUM WITHIN SIXTY (60) DAYS, THEN UTILITY MAY, AT ITS SOLE ELECTION AND WITHOUT NOTICE, REVOKE THIS AGREEMENT AND RESCIND ANY CONSENTS PREVIOUSLY GRANTED TO OWNER RELATED TO SAID STRUCTURE, WITHOUT FURTHER LIABILITY TO UTILITY.**

In consideration of the consent hereinabove granted by the Utility to Owner, and in consideration of the use of said portions of the Easement Area Owner obtains hereby, **OWNER, TO THE EXTENT ALLOWED BY LAW, HEREBY BINDS ITSELF, ITS SUCCESSORS, ASSIGNS, AGENTS, AND LICENSEES TO INDEMNIFY AND HOLD HARMLESS THE UTILITY FROM AND AGAINST ANY AND ALL CLAIMS, ACTIONS, CAUSES OF ACTION, DEMANDS, LIABILITIES, COSTS, LOSSES, EXPENSES AND DAMAGES, IN CONTRACT, STRICT LIABILITY OR IN TORT, INJURY TO ANY PERSON (INCLUDING DEATH) OR DAMAGE TO ANY PROPERTY ARISING OUT OF OR IN ANY WAY CONNECTED WITH THE CONSTRUCTION, USE AND EXISTENCE OF SAID STRUCTURE ON SAID PORTION OF SAID EASEMENT AREA, WHERE SUCH INJURY OR DAMAGE IS CAUSED BY THE SOLE, JOINT, CONCURRENT, CONTRIBUTING OR COMPARATIVE NEGLIGENCE OR FAULT OF OWNER, ITS AGENTS, OR EMPLOYEES, AND EVEN WHEN CAUSED BY THE JOINT, CONCURRENT, CONTRIBUTING OR COMPARATIVE NEGLIGENCE OR FAULT OF THE UTILITY, THEIR AGENTS OR EMPLOYEES, AND EVEN WHEN THE INJURY OR DAMAGE IS CAUSED BY THE SOLE NEGLIGENCE OF THE UTILITY, ITS AGENTS, OR EMPLOYEES.**

OWNER, TO THE EXTENT ALLOWED BY LAW, HEREBY AGREES TO ASSUME ALL LIABILITY FOR ANY DAMAGE TO THE UTILITY'S FACILITIES CAUSED BY OR ANY WAY CONNECTED WITH THE MAINTENANCE OF SAID STRUCTURE AND FURTHER AGREES TO REIMBURSE UTILITY FOR

ALL COST, INCLUDING BUT NO LIMITED TO, LOSS OF RELATED INCOME, PROPERTY DAMAGES, REIMBURSEMENTS, LEGAL FEES AND PERSONAL DAMAGES.

Owner further agrees that if the Utility shall at any time in its sole discretion determine that it is necessary to do so for the purpose of properly maintaining its Facilities, it shall be privileged to remove or alter the Structure, or any part thereof, and which the Utility agrees to restore as nearly as practical to their former condition, all at Owner's cost. Owner, to the extent allowed by law, hereby releases the Utility from any and all liability for damage caused to the Structure by any such removal, alteration or restoration and further agrees to pay to the Utility the cost of removing, altering or restoring such Structure upon receipt of its billing therefore. Owner, to the extent allowed by law, hereby further releases the Utility from any and all liability for loss of or damage to such Structure which may be caused by, result from or be related to the presence or malfunctioning of its Facilities and regardless of whether the negligence of the Utility may contribute to such loss or damage.

Owner further agrees that if the Utility shall at any time, and because of the presence of such Structure within said Easement Area, be ordered by any public authority having jurisdiction to remove or relocate its Facilities, it shall be privileged to comply with such order at Owner's cost, unless Owner, shall alter or remove said Structure to the satisfaction of such public authority upon reasonable notice to do so, at which time Owner will have thirty (30) days from completion of said alteration or removal to notify Utility in writing; and if such Facilities are removed or relocated by the Utility, Owner agrees to pay the cost thereof upon receipt of its billing therefor.

IF THIS PROPERTY CHANGES HANDS BEFORE RECORDATION OF THIS INSTRUMENT, OWNER AGREES TO GIVE NOTICE OF THIS INSTRUMENT TO THE PURCHASER.

If this Consent to Encroach is not accepted and agreed, notarized and returned by _____, 2025, this document shall become null and void.

EXECUTED this _____ day of _____, 2025

CenterPoint Energy Houston Electric, LLC

By: _____

Matthew R. Dowell
Manager, Land Management Division
Agent & Attorney-in-Fact

ACCEPTED and agreed to this _____ day of _____, 2025.

County of Fort Bend, Texas, a body politic and corporate and political subdivision of the State of Texas

Signature

Title

Name typed or printed

Acknowledgment Block for CenterPoint Energy’s Use Only:

STATE OF TEXAS }

COUNTY OF HARRIS }

This instrument was acknowledged before me on _____, 2025 by Matthew R. Dowell, Manager of the Land Management Division of CenterPoint Energy Houston Electric, LLC, as Agent and Attorney-in-Fact, on behalf of said corporation.

Notary Public in and for
The State of Texas

Acknowledgment Block for a Corporate Officer Only:

STATE OF TEXAS }

COUNTY OF }

This instrument was acknowledged before me by _____,
_____, of _____, on behalf of said County.

GIVEN UNDER MY HAND AND SEAL OF OFFICE this _____ day of _____,
2025.

Notary Public in and for
The State of Texas

AFTER RECORDING RETURN TO:
SURVEYING & RIGHT OF WAY
CENTERPOINT ENERGY HOUSTON ELECTRIC, LLC
P. O. BOX 1700
HOUSTON, TX 77251-1700

Exhibit "A" (Page 1 of 4)

CURVE TABLE			
CURVE	DELTA	RADIUS	CHORD
C1	12°04'17" LT	24.50'	509°02'16"E 5.15'
C2	46°34'15" RT	19.50'	15.85' N20°17'00"E 15.42'

LINE TABLE		
LINE	BEARING	DISTANCE
L1	N87°19'34"E	27.00'
L2	S03°00'07"E	4.88'
L3	S87°19'34"W	27.54'
L4	N03°00'07"W	10.00'
L5	N03°00'07"W	5.80'

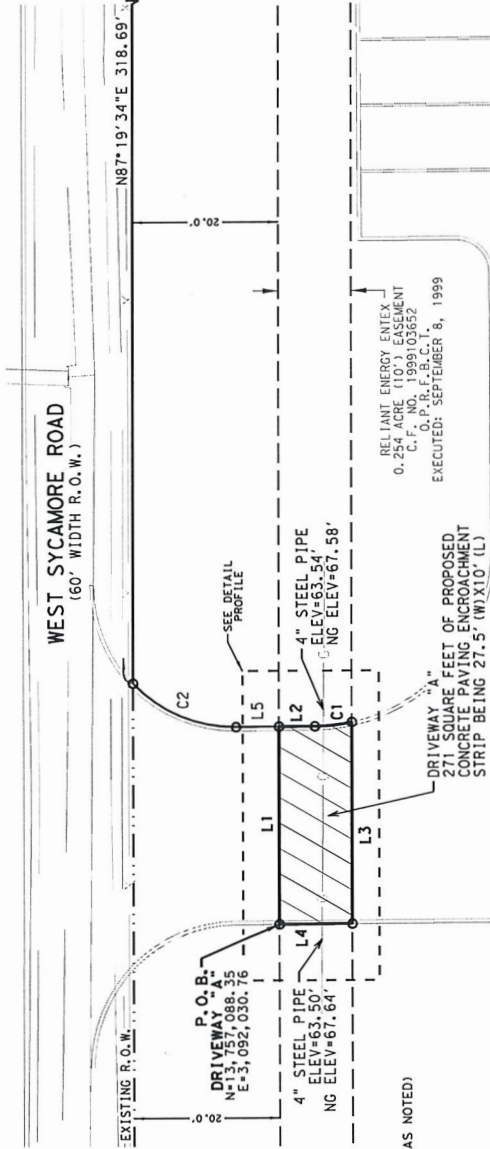

LEGEND

- POINT
- FOUND MONUMENT (AS NOTED)
- R.O.W.
- RIGHT-OF-WAY
- ELEVATION
- ELEV
- NATURAL GROUND
- NG
- PROPERTY LINE
- PLAT RECORDS FORT BEND COUNTY, TEXAS
- O.P.F.B.C.T.
- OFFICIAL PUBLIC RECORDS FORT BEND COUNTY, TEXAS
- POINT OF BEGINNING
- P.O.B.
- EXISTING RIGHT OF WAY

NOTES:
 1. ALL BEARINGS AND COORDINATES SHOWN HEREON ARE IN THE 1983 TEXAS COORDINATE SYSTEM, SOUTH ZONE (4204) NAD83. ALL COORDINATES AND DISTANCES SHOWN HEREON ARE SURFACE AND MAY BE CONVERTED TO GRID BY DIVIDING BY A COMBINED ADJUSTMENT FACTOR OF 1.000130 (FORT BEND COUNTY).
 2. IMPROVEMENTS AND PAYMENT SHOWN ARE PROPOSED AND NOT EXISTING AT TIME OF SURVEY.

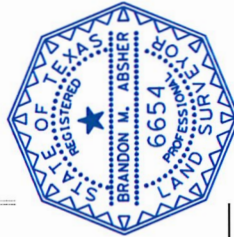

2025.06.03
 15:52:24 -05'00'

SIGNED: *Brandon M. Absher*
 BRANDON M. ABSHER
 REGISTERED PROFESSIONAL LAND SURVEYOR
 TEXAS No. 6654

PROPOSED CONCRETE PAVING PROFILE

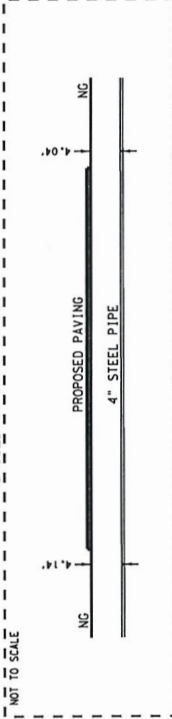

NOT TO SCALE

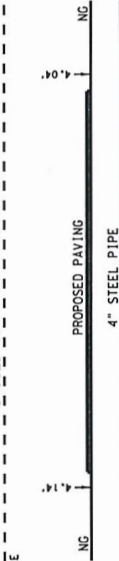

4.00'

PROPOSED PAVING

4" STEEL PIPE

NG

NG

4.00'

4.00'

4.00'

4.00'

4.00'

4.00'

4.00'

4.00'

4.00'

4.00'

NG

NG

4.00'

4.00'

4.00'

4.00'

4.00'

4.00'

4.00'

4.00'

4.00'

NG

NG

4.00'

4.00'

4.00'

4.00'

4.00'

4.00'

4.00'

4.00'

4.00'

NG

NG

4.00'

4.00'

4.00'

4.00'

4.00'

4.00'

4.00'

4.00'

4.00'

NG

NG

4.00'

4.00'

4.00'

4.00'

4.00'

4.00'

4.00'

4.00'

4.00'

NG

NG

4.00'

4.00'

4.00'

4.00'

4.00'

4.00'

4.00'

4.00'

4.00'

NG

NG

4.00'

4.00'

4.00'

4.00'

4.00'

4.00'

4.00'

4.00'

4.00'

NG

NG

4.00'

4.00'

4.00'

4.00'

4.00'

4.00'

4.00'

4.00'

4.00'

NG

NG

4.00'

4.00'

4.00'

4.00'

4.00'

4.00'

4.00'

4.00'

4.00'

NG

NG

4.00'

4.00'

4.00'

4.00'

4.00'

4.00'

4.00'

4.00'

4.00'

NG

NG

4.00'

4.00'

4.00'

4.00'

4.00'

4.00'

4.00'

4.00'

4.00'

NG

NG

4.00'

4.00'

4.00'

4.00'

4.00'

4.00'

4.00'

4.00'

4.00'

NG

NG

4.00'

4.00'

4.00'

4.00'

4.00'

4.00'

4.00'

4.00'

4.00'

NG

NG

4.00'

4.00'

4.00'

4.00'

4.00'

4.00'

4.00'

4.00'

4.00'

NG

NG

4.00'

4.00'

4.00'

4.00'

4.00'

4.00'

4.00'

4.00'

4.00'

NG

NG

4.00'

4.00'

4.00'

4.00'

4.00'

4.00'

4.00'

4.00'

4.00'

NG

NG

4.00'

4.00'

4.00'

4.00'

4.00'

4.00'

4.00'

4.00'

4.00'

NG

NG

4.00'

4.00'

4.00'

4.00'

4.00'

4.00'

4.00'

4.00'

4.00'

NG

NG

4.00'

4.00'

4.00'

4.00'

4.00'

4.00'

4.00'

4.00'

4.00'

NG

NG

4.00'

4.00'

4.00'

4.00'

4.00'

4.00'

4.00'

4.00'

4.00'

NG

NG

4.00'

4.00'

4.00'

4.00'

4.00'

4.00'

4.00'

4.00'

4.00'

NG

NG

4.00'

4.00'

4.00'

4.00'

4.00'

4.00'

4.00'

4.00'

4.00'

NG

NG

4.00'

4.00'

4.00'

4.00'

4.00'

Exhibit "A" (Page 2 of 4)

- NOTES:**
1. ALL BEARINGS AND COORDINATES SHOWN HEREON ARE BASED ON THE TEXAS COORDINATE SYSTEM, SOUTH CENTRAL ZONE (4204), NAD83. ALL COORDINATES AND DISTANCES SHOWN HEREON ARE SURFACE AND MAY BE CONVERTED TO GRID BY DIVIDING BY A COMBINED ADJUSTMENT FACTOR OF 1.000130 (FORT BEND COUNTY).
 2. IMPROVEMENTS AND PAVEMENT SHOWN ARE PROPOSED AND NOT EXISTING AT TIME OF SURVEY.

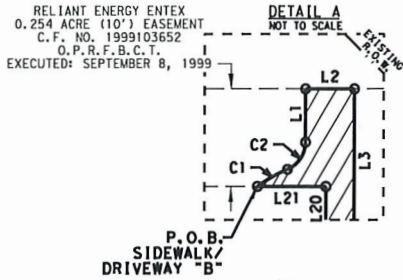
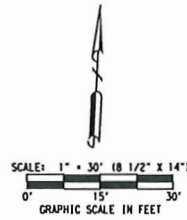

CURVE TABLE				
CURVE	DELTA	RADIUS	ARC LENGTH	CHORD
C1	13° 37' 20" RT	15.00'	3.57'	N57° 51' 40" E 3.56'
C2	67° 20' 39" LT	3.00'	3.53'	N31° 00' 01" E 3.33'
C3	28° 23' 30" LT	15.00'	7.43'	S16° 52' 03" E 7.36'
C4	07° 13' 30" RT	104.99'	13.24'	S27° 27' 04" E 13.23'
C5	14° 54' 29" RT	104.99'	27.32'	S16° 23' 04" E 27.24'
C11	27° 12' 16" LT	100.00'	47.48'	N16° 36' 15" W 47.03'

LINE TABLE		
LINE	BEARING	DISTANCE
L1	N02° 40' 18" W	5.48'
L2	N87° 19' 34" E	5.00'
L3	S02° 40' 18" E	37.10'
L4	N02° 57' 31" W	53.80'
L5	S02° 56' 09" E	168.23'
L18	N03° 00' 07" W	152.37'
L19	N30° 38' 11" W	1.72'
L20	N02° 57' 31" W	36.41'
L21	S87° 19' 34" W	7.06'

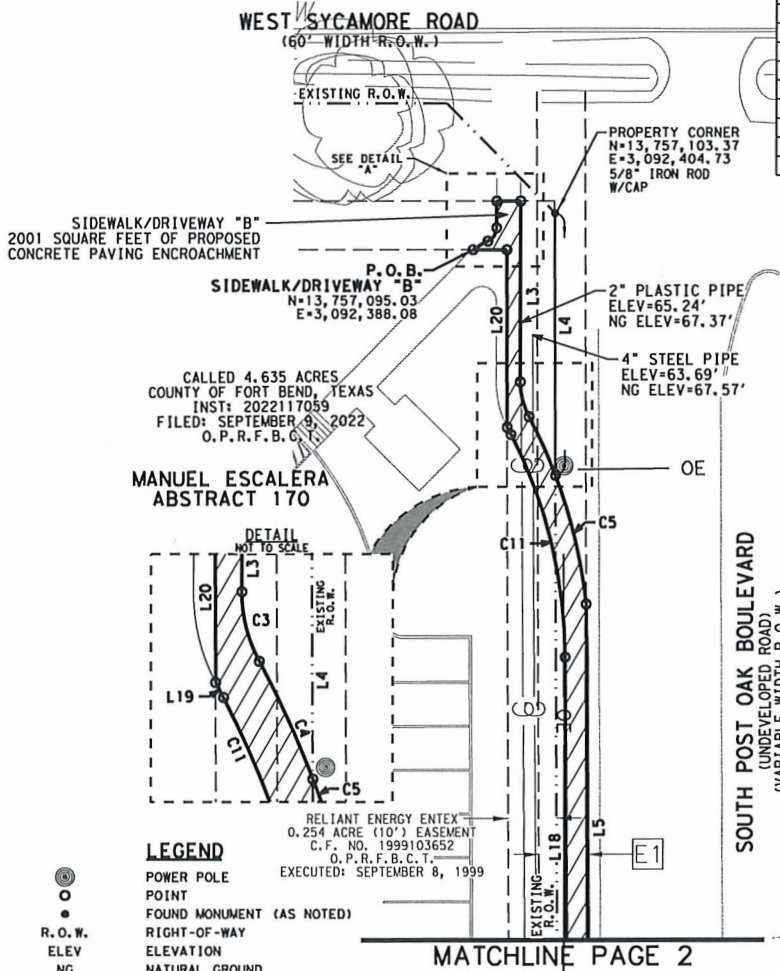

E1
 CENTERPOINT ENERGY
 HOUSTON ELECTRIC, LLC
 (110') AERIAL EASEMENT
 C.F. NO. 2011050348
 O.P.R.F.B.C.T.
 EXECUTED: MAY 12, 2011

LEGEND

- POWER POLE
- POINT
- FOUND MONUMENT (AS NOTED)
- R.O.W.
- ELEV
- NG
- PL
- P.R.F.B.C.T.
- O.P.R.F.B.C.T.
- P.O.B.
- OE
- G
- — — — —

- POWER POLE
- POINT
- FOUND MONUMENT (AS NOTED)
- R.O.W.
- ELEV
- NG
- PL
- P.R.F.B.C.T.
- O.P.R.F.B.C.T.
- P.O.B.
- OE
- G
- — — — —



**PROPOSED
 CENTERPOINT ENERGY PAVEMENT
 ENCROACHMENT
 SIDEWALK/DRIVEWAY "B"**

SCALE:	JOB NUMBER:	DATE:	PAGE:
1" = 30'	24-098-01	03/26/2025	2 OF 3



SIGNED: *Brandon M. Absher* 2025.06.03 15:53:21
 -05'00"
 BRANDON M. ABSHER
 REGISTERED PROFESSIONAL LAND SURVEYOR
 TEXAS No. 6654

Exhibit "A" (Page 3 of 4)

NOTES:
 1. ALL BEARINGS AND COORDINATES SHOWN HEREON ARE BASED ON THE TEXAS COORDINATE SYSTEM, SOUTH CENTRAL ZONE (4204), NAD83. ALL COORDINATES AND DISTANCES SHOWN HEREON ARE SURFACE AND MAY BE CONVERTED TO GRID BY DIVIDING BY A COMBINED ADJUSTMENT FACTOR OF 1.000130 (FORT BEND COUNTY).
 2. IMPROVEMENTS AND PAVEMENT SHOWN ARE PROPOSED AND NOT EXISTING AT TIME OF SURVEY.

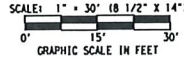

E3

CENTERPOINT ENERGY
 HOUSTON ELECTRIC, LLC
 (30') AERIAL EASEMENT
 C.F. NO. 2011071815
 O.P.R.F.B.C.T.
 EXECUTED: JUNE 23, 2011

E2

RELIANT ENERGY ENTEX
 0.070 ACRE (8') EASEMENT
 C.F. NO. 1999103653
 O.P.R.F.B.C.T.
 EXECUTED: SEPTEMBER 8, 1999

E1

CENTERPOINT ENERGY
 HOUSTON ELECTRIC, LLC
 (10') EASEMENT
 C.F. NO. 2011050348
 O.P.R.F.B.C.T.
 EXECUTED: MAY 12, 2011

CURVE TABLE				
CURVE	DELTA	RADIUS	ARC LENGTH	CHORD
C6	09° 45' 53" LT	5.00'	0.85'	S01° 52' 49" W 0.85'
C7	90° 03' 26" LT	24.50'	38.51'	N47° 58' 22" W 34.67'
C8	27° 11' 14" LT	24.50'	11.63'	N59° 17' 36" E 11.52'
C9	10° 25' 05" RT	10.00'	1.82'	N02° 12' 25" E 1.82'
C10	10° 22' 55" LT	5.00'	0.91'	N02° 15' 09" E 0.90'

MATCHLINE PAGE 1

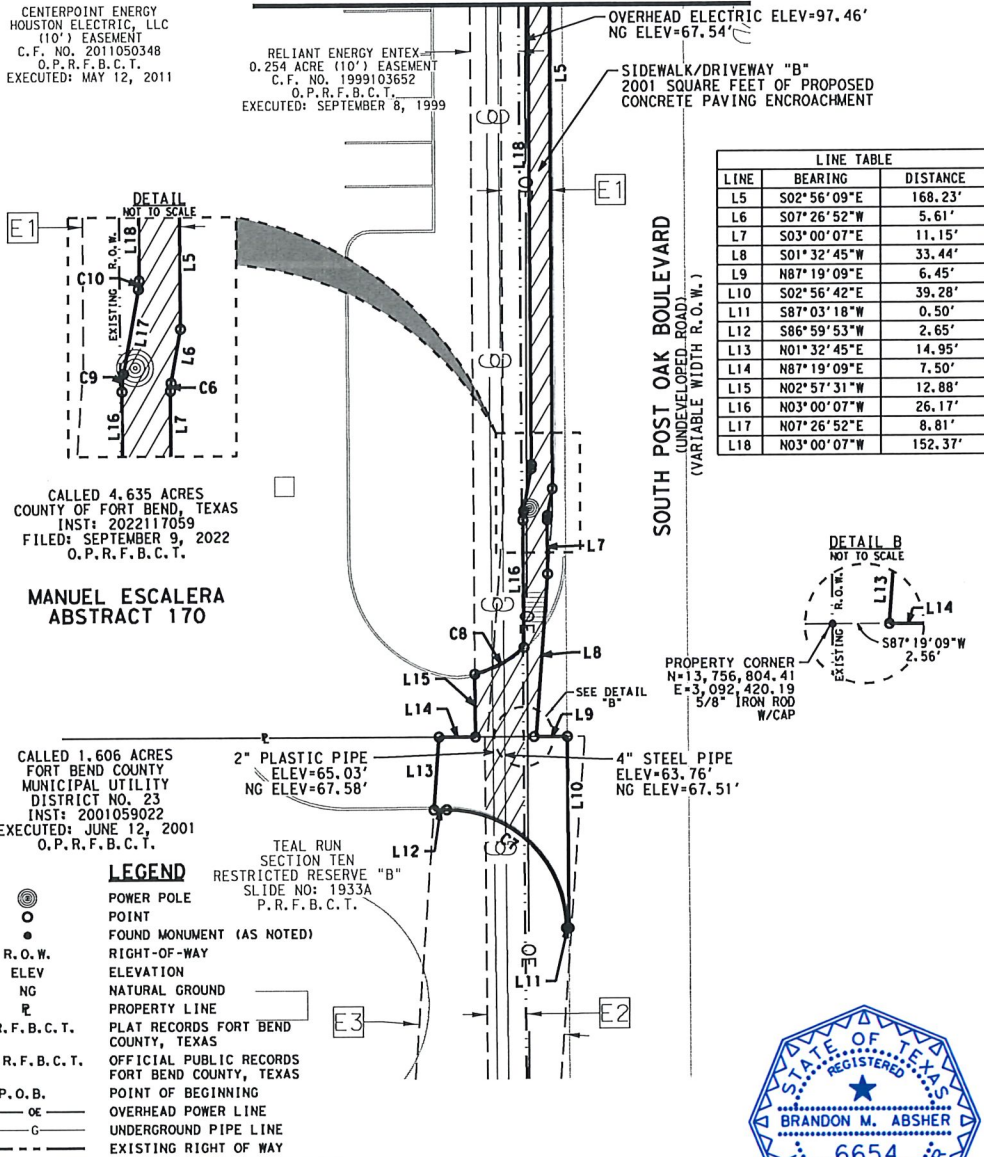

LINE TABLE		
LINE	BEARING	DISTANCE
L5	S02° 56' 09" E	168.23'
L6	S07° 26' 52" W	5.61'
L7	S03° 00' 07" E	11.15'
L8	S01° 32' 45" W	33.44'
L9	N87° 19' 09" E	6.45'
L10	S02° 56' 42" E	39.28'
L11	S87° 03' 18" W	0.50'
L12	S86° 59' 53" W	2.65'
L13	N01° 32' 45" E	14.95'
L14	N87° 19' 09" E	7.50'
L15	N02° 57' 31" W	12.88'
L16	N03° 00' 07" W	26.17'
L17	N07° 26' 52" E	8.81'
L18	N03° 00' 07" W	152.37'

CALLED 4.635 ACRES
 COUNTY OF FORT BEND, TEXAS
 INST: 2022117059
 FILED: SEPTEMBER 9, 2022
 O.P.R.F.B.C.T.

**MANUEL ESCALERA
 ABSTRACT 170**

CALLLED 1.606 ACRES
 FORT BEND COUNTY
 MUNICIPAL UTILITY
 DISTRICT NO. 23
 INST: 2001059022
 EXECUTED: JUNE 12, 2001
 O.P.R.F.B.C.T.

LEGEND

- ⊙ POWER POLE
- POINT
- FOUND MONUMENT (AS NOTED)
- R.O.W. RIGHT-OF-WAY
- ELEV. ELEVATION
- NG. NATURAL GROUND
- P.L. PROPERTY LINE
- P.R.F.B.C.T. PLAT RECORDS FORT BEND COUNTY, TEXAS
- O.P.R.F.B.C.T. OFFICIAL PUBLIC RECORDS FORT BEND COUNTY, TEXAS
- P.O.B. POINT OF BEGINNING
- OE OVERHEAD POWER LINE
- G UNDERGROUND PIPE LINE
- --- EXISTING RIGHT OF WAY

Civil Corp

4811 AIRLINE ROAD, SUITE 300, VICTORIA, TEXAS 77904
 TEL: 409-575-1100 FAX: 409-575-1101

**PROPOSED
 CENTERPOINT ENERGY PAVEMENT
 ENCROACHMENT
 SIDEWALK/DRIVEWAY "B"**

SCALE	JOB NUMBER	DATE	PAGE
1" = 30'	24-098-01	03/26/2025	2 OF 3



SIGNED: *Brandon Absher* 2025.06.03 15:53:55 -05'00'
 BRANDON M. ABSHER
 REGISTERED PROFESSIONAL LAND SURVEYOR
 TEXAS No. 6654

Exhibit "A" (Page 4 of 4)

NOT TO SCALE

OVERHEAD ELECTRIC AND PIPE PROFILE

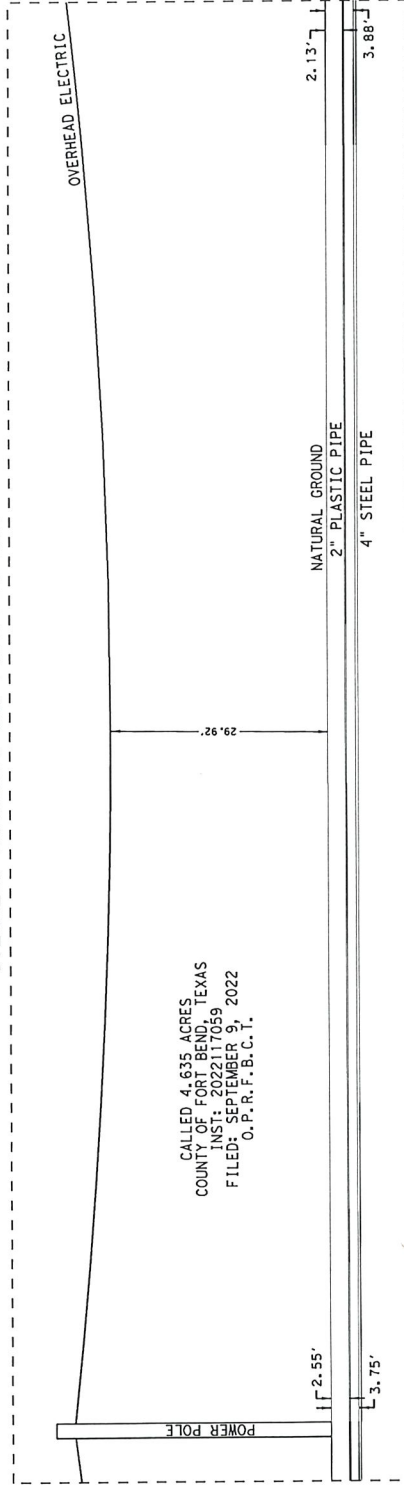

CALLED 4.635 ACRES
 COUNTY OF FORT BEND, TEXAS
 INST: 2022117059
 FILED: SEPTEMBER 9, 2022
 O.P.R. F.B.C.T.

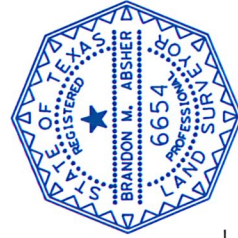

2025.06.03
 15:53:49 -05'00'

SIGNED: *Brandon M. Arsher*
 BRANDON M. ARSHER
 REGISTERED PROFESSIONAL LAND SURVEYOR
 TEXAS No. 6654



PROPOSED
 CENTERPOINT ENERGY PAVEMENT
 ENCROACHMENT
 SIDEWALK/DRIVEWAY "B"
 PROFILE

SCALE:	JOB NUMBER:	DATE:	PAGE:
N. T. S.	24-098-01	03/26/2025	3 OF 3

EXHIBIT B

16.10 Protective Barrier Layout

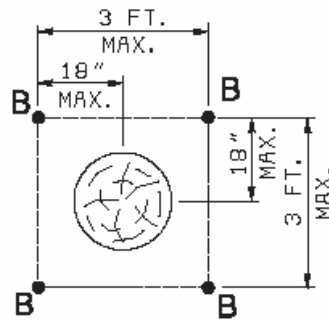

WOOD POLE

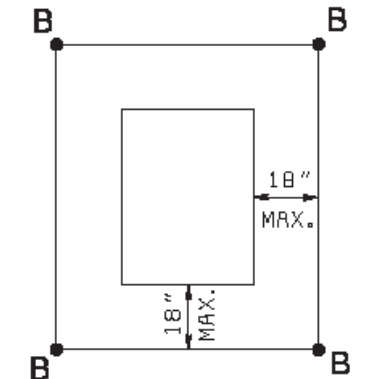

CABLE TERMINAL BOX

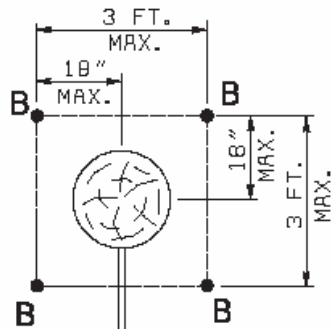

DOWN GUY

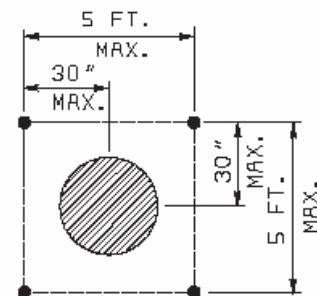
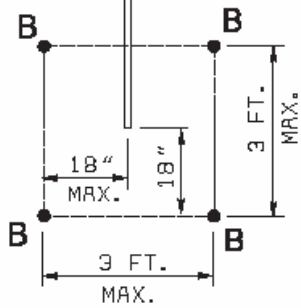

STEEL POLE

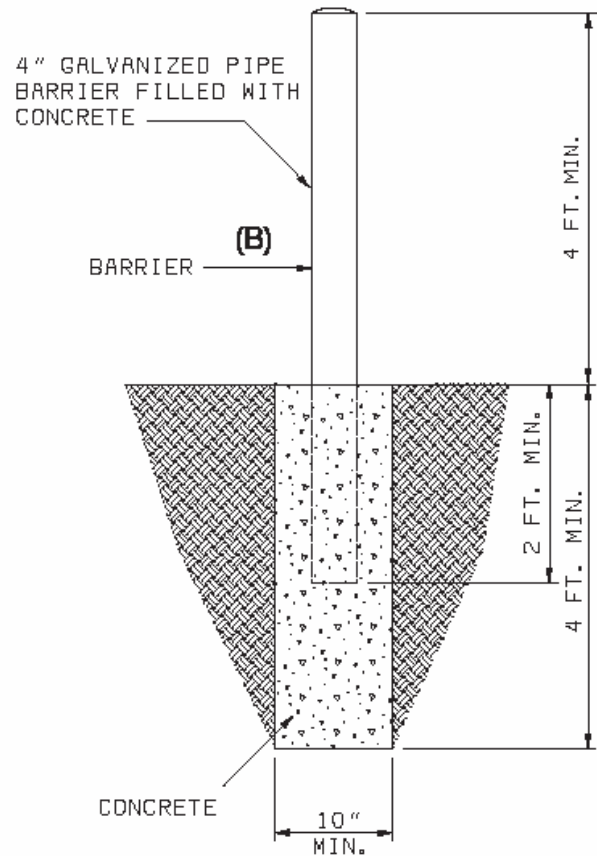

BARRIER DETAIL