

STATE OF TEXAS §
 §
COUNTY OF FORT BEND §

**SECOND AMENDMENT TO AGREEMENT FOR DESIGN/BUILD
FOR NORTH ANNEX PARKING EXPANSION
(CONSTRUCTION PHASE)
RFQ 24-024**

THIS SECOND AMENDMENT (“Second Amendment”) is made and entered into by and between Fort Bend County, (hereinafter “County”), a body corporate and politic under the laws of the State of Texas, and APEX Consulting Group, Inc., (hereinafter “ACG”), a company authorized to conduct business in the State of Texas (hereinafter each referred to as a “party” or collectively as the “parties”).

WITNESSETH

WHEREAS, on or about April 23, 2024, the Parties executed and accepted that certain Agreement for the Design/Build of North Annex Parking Expansion (hereinafter “Agreement”), and as amended by documents executed on August 13, 2024 (hereinafter “First Amendment”) which are incorporated by reference as if set forth herein verbatim; and

WHEREAS, by execution of this Second Amendment, the Parties desire to amend the Agreement to provide for additional services in the Construction phase of the agreement and to increase the Total Maximum Compensation for completion of such services, and to otherwise ratify and confirm all the terms and conditions as set forth herein.

NOW THEREFORE, in consideration of the foregoing, the Parties do mutually agree that the Agreement between the Parties is hereby amended as follows:

1. **Scope of Services.** County shall pay ACG an additional Sixteen Thousand One Hundred and 00/100 dollars (\$16,100.00) for the performance and completion of construction services as described in ACG’s Quote dated October 24, 2024 (the “Services”) attached hereto as Exhibit “A” and incorporated by reference for all intents and purposes.
2. **Limit of Appropriation.** ACG understands and agrees that the Maximum Compensation payable to ACG for Services rendered under this Agreement is hereby increased to an amount not to exceed Two

Hundred Forty-One Thousand One Hundred and 00/100 dollars (\$241,100.00), authorized as follows:

\$ 12,500.00	under the Agreement
\$212,500.00	under the First Amendment
\$ 16,100.00	under this Second Amendment
TOTAL	\$241,100.00

In no event shall the amount paid by County under this Agreement exceed the Maximum Compensation without a County approved change order. ACG clearly understands and agrees, such understanding and agreement being the absolute essence of this Agreement, that County shall have available the total maximum sum of Two Hundred Forty-One Thousand One Hundred and 00/100 dollars (\$241,100.00) specifically allocated to fully discharge any and all liabilities County may incur under the Agreement.

ACG does further understand and agree, said understanding and agreement also being of the absolute essence of the Agreement, that the total Maximum Compensation that ACG may become entitled to and the total maximum sum that County may become liable to pay to ACG under the Agreement shall not under any conditions, circumstances, or interpretations thereof exceed Two Hundred Forty-One Thousand One Hundred and 00/100 dollars (\$241,100.00).

3. **Recitals.** The recitals set forth above are incorporated herein by reference and made a part of the Agreement.
4. **Modifications and Conflict.** Except as modified herein, the Agreement shall remain in full force and effect and has not been otherwise modified or amended. If there is a conflict among documents that make up the Agreement, this Second Amendment shall prevail with regard to the conflict.

{Remainder of Page Intentionally Left Blank}

{Execution Page Follows}

IN WITNESS WHEREOF, the parties hereto have signed or have caused their respective names to be signed to multiple counterparts to be effective on the day signed by the last party.

FORT BEND COUNTY

APEX CONSULTING GROUP, INC.

KP GEORGE, COUNTY JUDGE



AUTHORIZED AGENT - SIGNATURE

DATE

Charles Mgbeike, P.E.

AUTHORIZED AGENT- PRINTED NAME

ATTEST:

TITLE

LAURA RICHARD, COUNTY CLERK

11/04/24

DATE

APPROVED:



JAMES KNIGHT, FACILITIES MANAGEMENT/
PLANNING DIRECTOR

AUDITOR'S CERTIFICATE

I hereby certify that funds are available in the amount of \$_____ to accomplish and pay the obligation of Fort Bend County under this contract.

Robert Ed Sturdivant, County Auditor

Exhibit A: APEX Consulting Group, Inc.'s Construction Fee Proposal, dated October 24, 2024

i:\agreements\2024 agreements\facilities\apex consulting group, inc. (24-fac-100536-a2)\second amendment to agreement for design-build services (north annex parking expansion).docx (DRP 10.30.24)

SECOND AMENDMENT TO AGREEMENT FOR DESIGN/BUILD FOR NORTH ANNEX PARKING EXPANSION DESIGN

RFQ 24-024

Page 3 of 4

EXHIBIT A



CHANGE PROPOSAL REQUEST #1

Date: 10/24/24

Project:
FBC NORTH ANNEX
22333 GRAND CORNER
KATY TX

Owner:
FORT BEND COUNTY
301 JACKSON STR
RICHMOND, TX 77469

Contractor:
APEX Consulting Group
9888 Bissonnet Street, #415
Houston, TX 77036

THE CONTRACT IS CHANGED AS FOLLOWS:

Description of Revisions	Amount
ADD AWNING FOR CONSTABLE MOTORCYCLE PARKING	\$16,100.00
Total	\$16,100.00

NOT VALID UNTIL SIGNED BY OWNER AND CONTRACTOR

This Contingency Credit is specific in and final as to price and extension of time, with no reservations or other provisions allowing for future additional costs or time from changes identified and fully compensated in this Contingency Credit. Signature of the Contractor indicates agreement herewith, including adjustments to the contract term and contract time

Previous authorized Change Order(s):	\$0.00
Current Change Order:	\$16,100.00
Total Change Order to Date:	\$16,100.00

Authorized

James Knight, Director, FBC Facilities

APEX Consulting Group, Contractor

10/24/24

FBC NORTH ANNEX - AWNING FOR CONSTABLE MOTORCYCLE PARKING

APEX CONSULTING GROUP	
Schedule of Values	
General Conditions	
Site Supervision & Management	\$ 1,200.00
Overhead & Profit	\$ 1,800.00
Insurance	\$ 600.00
Equipment Rental	\$ 500.00
Total - General Conditions	\$ 4,100.00
General Requirements	\$ -
Site Clean -up	\$ 500.00
Total - General Requirements	\$ 500.00
Steel Structure	\$ -
Structure - Galv steel, roofing, purlins, etc	\$ 8,500.00
Engineering & Permit	\$ 1,500.00
Total - Steel Structure	\$ 10,000.00
Foundation	
Isolated footing	\$ 1,500.00
Sub Total	\$ 12,000.00
Base Bid	\$ 16,100.00

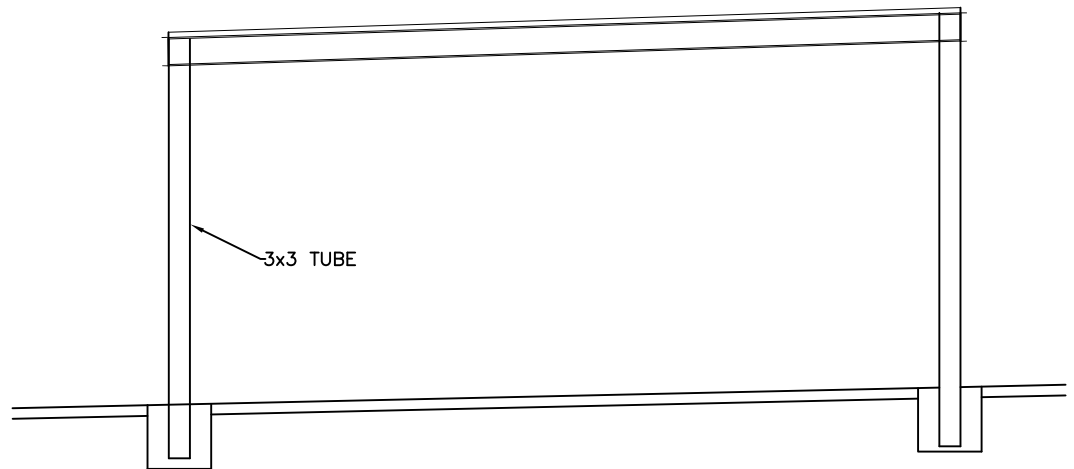
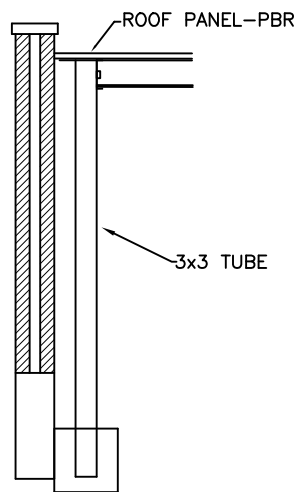
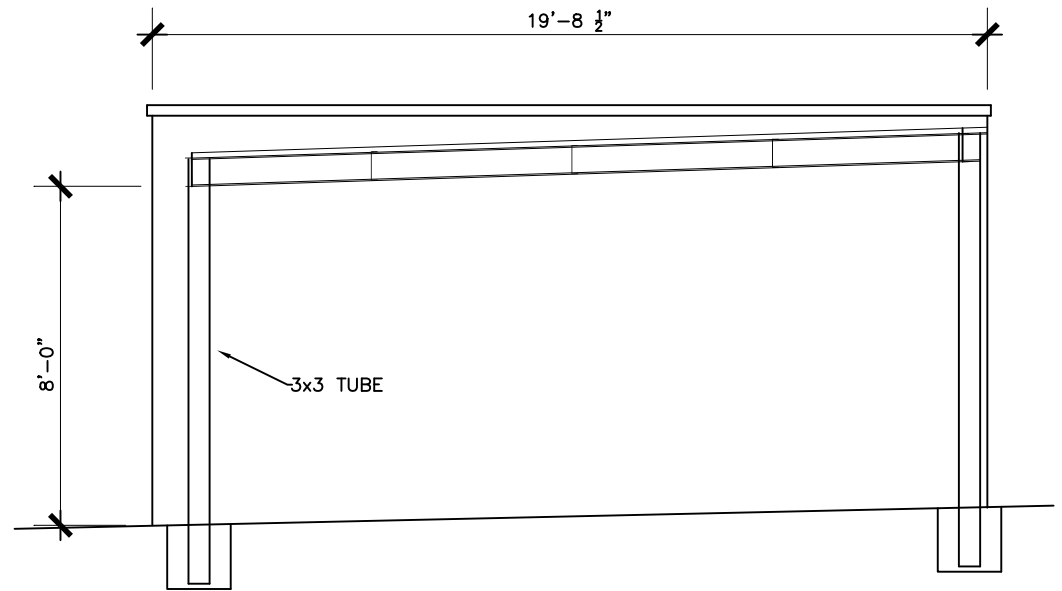
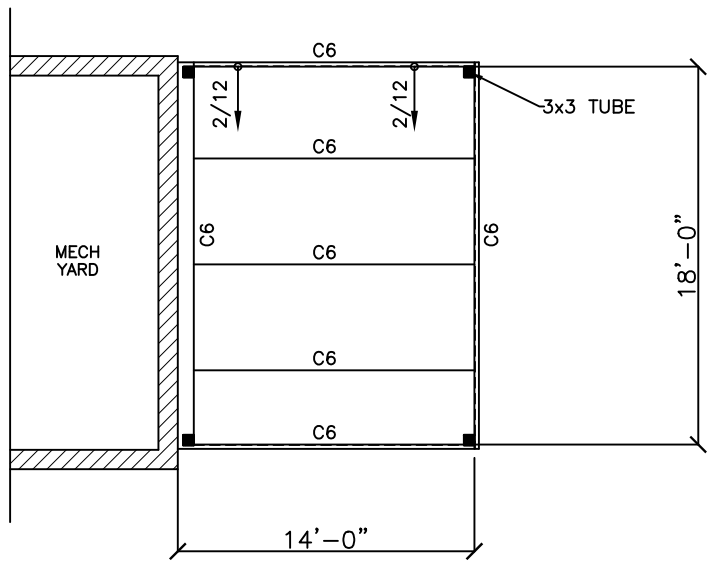

FBC - AWNING FOR CONSTABLE MOTORCYCLE PARKING