

**PLAT RECORDING SHEET**

**PLAT NAME:** Sienna Plantation, Section 14

**PLAT NO:** \_\_\_\_\_

**ACREAGE:** 27.144

**LEAGUE:** David Fitzgerald League, William Hall League

**ABSTRACT NUMBER:** 25, 31

**NUMBER OF BLOCKS:** 4

**NUMBER OF LOTS:** 100

**NUMBER OF RESERVES:** 6

**OWNERS:** Toll-Gtis Property Owner, LLC and Sienna Plantation Levee Impr. Dist.

\_\_\_\_\_  
**(DEPUTY CLERK)**

STATE OF TEXAS  
COUNTY OF FORT BEND

WE, TOLL-GTIS PROPERTY OWNER, LLC, A TEXAS LIMITED LIABILITY COMPANY, ACTING BY AND THROUGH JIMMIE F. JENKINS, AUTHORIZED REPRESENTATIVE, BEING AN OFFICER OF TOLL-GTIS PROPERTY OWNER, LLC, A TEXAS LIMITED LIABILITY COMPANY, AND WE, SIENNA PLANTATION LEVEE IMPROVEMENT DISTRICT, ACTING BY AND THROUGH KEN BECKMAN, PRESIDENT BEING AN OFFICER OF SIENNA PLANTATION LEVEE IMPROVEMENT DISTRICT, OWNERS OF THE 27.144 ACRE TRACT DESCRIBED IN THE ABOVE AND FOREGOING PLAT OF SIENNA PLANTATION SECTION 14, DO HEREBY MAKE AND ESTABLISH SAID SUBDIVISION PLAT OF SAID PROPERTY ACCORDING TO ALL LINES, DEDICATIONS, RESTRICTIONS AND NOTATIONS ON SAID PLAT AND HEREBY DEDICATE TO THE USE OF THE PUBLIC FOREVER, ALL STREETS, ALLEYS, PARKS, WATER COURSES, DRAINS, EASEMENTS AND PUBLIC PLACES SHOWN THEREON FOR THE PURPOSES AND CONSIDERATIONS THEREIN EXPRESSED, AND DO HEREBY BIND OURSELVES, OUR HEIRS AND ASSIGNS TO WARRANT AND FOREVER DEFEND THE TITLE TO THE LAND SO DEDICATED.

WE FURTHER ACKNOWLEDGE THAT THE DEDICATIONS AND/OR EXACTIONS MADE HEREIN ARE PROPORTIONAL TO THE IMPACT OF THE SUBDIVISION UPON THE PUBLIC SERVICES REQUIRED IN ORDER THAT THE DEVELOPMENT WILL COMPORT WITH THE PRESENT AND FUTURE GROWTH NEEDS OF THE CITY; WE, OUR SUCCESSORS AND ASSIGNEES HEREBY WAIVE ANY CLAIM, DAMAGE OR CAUSE OF ACTION THAT WE MAY HAVE AS A RESULT OF THE DEDICATION OR EXACTIONS MADE HEREIN.

FURTHER, OWNERS HAVE DEDICATED AND BY THESE PRESENTS DO DEDICATE TO THE USE OF THE PUBLIC FOR PUBLIC UTILITY PURPOSES FOREVER UNOBSTRUCTED AERIAL EASEMENTS. THE AERIAL EASEMENTS SHALL EXTEND HORIZONTALLY AN ADDITIONAL ELEVEN FEET, SIX INCHES (11'6") FOR TEN FEET (10'0") PERIMETER GROUND EASEMENTS OR SEVEN FEET, SIX INCHES (7'6") FOR FOURTEEN FEET (14'0") PERIMETER GROUND EASEMENTS OR FIVE FEET, SIX INCHES (5'6") FOR SIXTEEN FEET (16'0") PERIMETER GROUND EASEMENTS, FROM A PLANE SIXTEEN FEET (16'0") ABOVE GROUND LEVEL UPWARD, LOCATED ADJACENT TO AND ADJOINING SAID PUBLIC UTILITY EASEMENTS THAT ARE DESIGNATED WITH AERIAL EASEMENTS (U.E. AND A.E.) AS INDICATED AND DEPICTED, HEREON, WHEREBY THE AERIAL EASEMENT TOTALS TWENTY ONE FEET, SIX INCHES (21' 6") IN WIDTH.

FURTHER, OWNERS HAVE DEDICATED AND BY THESE PRESENTS DO DEDICATE TO THE USE OF THE PUBLIC FOR PUBLIC UTILITY PURPOSES FOREVER UNOBSTRUCTED AERIAL EASEMENTS. THE AERIAL EASEMENTS SHALL EXTEND HORIZONTALLY AN ADDITIONAL TEN FEET (10'0") FOR TEN FEET (10'0") BACK-TO-BACK GROUND EASEMENTS, OR EIGHT FEET (8'0") FOR FOURTEEN FEET (14'0") BACK-TO-BACK GROUND EASEMENTS OR SEVEN FEET (7'0") FOR SIXTEEN FEET (16'0") BACK-TO-BACK GROUND EASEMENTS, FROM A PLANE SIXTEEN FEET (16'0") ABOVE GROUND LEVEL UPWARD, LOCATED ADJACENT TO AND ADJOINING SAID PUBLIC UTILITY EASEMENTS THAT ARE DESIGNATED WITH AERIAL EASEMENTS (U.E. AND A.E.) AS INDICATED AND DEPICTED HEREON, WHEREBY THE AERIAL EASEMENT TOTALS THIRTY FEET (30'0") IN WIDTH.

FURTHER, WE DO HEREBY DECLARE THAT ALL PARCELS OF LAND DESIGNATED AS LOTS ON THIS PLAT ARE INTENDED FOR THE CONSTRUCTION OF SINGLE FAMILY RESIDENTIAL DWELLING UNITS THEREON AND SHALL BE RESTRICTED FOR SAME UNDER THE TERMS AND CONDITIONS OF SUCH RESTRICTIONS FILED SEPARATELY.

FURTHER, WE DO HEREBY COVENANT AND AGREE THAT ALL OF THE PROPERTY WITHIN THE BOUNDARIES OF THIS PLAT SHALL BE RESTRICTED TO PREVENT THE DRAINAGE OF ANY SEPTIC TANKS INTO ANY PUBLIC OR PRIVATE STREET, ROAD OR ALLEY OR ANY DRAINAGE DITCH, EITHER DIRECTLY OR INDIRECTLY.

FURTHER, WE DO HEREBY DEDICATE TO THE PUBLIC A STRIP OF LAND TWENTY (20) FEET WIDE ON EACH SIDE OF THE CENTER LINE OF ANY AND ALL BAYOUS, CREEKS, GULLIES, RAVINES, DRAINS AND DRAINAGE DITCHES LOCATED IN SAID SUBDIVISION, AS EASEMENTS FOR DRAINAGE PURPOSES. FORT BEND COUNTY OR ANY OTHER GOVERNMENTAL AGENCY SHALL HAVE THE RIGHT TO ENTER UPON SAID EASEMENT AT ANY AND ALL TIMES FOR THE PURPOSES OF CONSTRUCTION AND MAINTENANCE OF DRAINAGE FACILITIES AND STRUCTURES.

FURTHER, WE DO HEREBY COVENANT AND AGREE THAT ALL OF THE PROPERTY WITHIN THE BOUNDARIES OF THIS SUBDIVISION AND ADJACENT TO ANY DRAINAGE EASEMENT, DITCH, GULLY, CREEK OR NATURAL DRAINAGE WAY SHALL HEREBY BE RESTRICTED TO KEEP SUCH DRAINAGE WAYS AND EASEMENTS CLEAR OF FENCES, BUILDINGS, EXCESSIVE VEGETATION AND OTHER OBSTRUCTIONS TO THE OPERATIONS AND MAINTENANCE OF THE DRAINAGE FACILITY AND THAT SUCH ADJUTING PROPERTY SHALL NOT BE PERMITTED TO DRAIN DIRECTLY INTO THIS EASEMENT EXCEPT BY MEANS OF AN APPROVED DRAINAGE STRUCTURE.

FURTHER, WE DO HEREBY CERTIFY THAT WE ARE THE OWNERS OF ALL PROPERTY IMMEDIATELY ADJACENT TO THE BOUNDARIES OF THE ABOVE AND FOREGOING SUBDIVISION OF SIENNA PLANTATION SECTION 14 WHERE BUILDING SETBACK LINES OR PUBLIC UTILITY EASEMENTS ARE TO BE ESTABLISHED OUTSIDE THE BOUNDARIES OF THE ABOVE AND FOREGOING SUBDIVISION AND DO HEREBY MAKE AND ESTABLISH ALL BUILDING SETBACK LINES AND DEDICATE TO THE USE OF THE PUBLIC, ALL PUBLIC UTILITY EASEMENTS SHOWN IN SAID ADJACENT ACREAGE.

FURTHER, WE DO HEREBY ACKNOWLEDGE THE RECEIPT OF THE "ORDERS FOR REGULATION OF OUTDOOR LIGHTING IN THE UNINCORPORATED AREAS OF FORT BEND COUNTY, TEXAS", AND DO HEREBY COVENANT AND AGREE AND SHALL COMPLY WITH THIS ORDER AS ADOPTED BY FORT BEND COUNTY COMMISSIONERS COURT ON MARCH 23, 2004 AND ANY SUBSEQUENT AMENDMENT.

IN TESTIMONY WHEREOF, TOLL-GTIS PROPERTY OWNER, LLC, A TEXAS LIMITED LIABILITY COMPANY, HAS CAUSED THESE PRESENTS TO BE SIGNED BY JIMMIE F. JENKINS, ITS AUTHORIZED REPRESENTATIVE, THEREUNTO AUTHORIZED, THIS 27<sup>th</sup> DAY OF September, 2018.

TOLL-GTIS PROPERTY OWNER, LLC  
A TEXAS LIMITED LIABILITY COMPANY

BY: J. Jenkins  
JIMMIE F. JENKINS, AUTHORIZED REPRESENTATIVE

STATE OF TEXAS  
COUNTY OF HARRIS

BEFORE ME, THE UNDERSIGNED AUTHORITY, ON THIS DAY PERSONALLY APPEARED JIMMIE F. JENKINS, AUTHORIZED REPRESENTATIVE OF TOLL-GTIS PROPERTY OWNER, LLC, A TEXAS LIMITED LIABILITY COMPANY, KNOWN TO ME TO BE THE PERSON WHOSE NAME IS SUBSCRIBED TO THE FOREGOING INSTRUMENT AND ACKNOWLEDGED TO ME THAT HE EXECUTED THE SAME FOR THE PURPOSES AND CONSIDERATIONS THEREIN EXPRESSED AND IN THE CAPACITY THEREIN AND HEREIN SET OUT.

GIVEN UNDER MY HAND AND SEAL OF OFFICE, THIS 27<sup>th</sup> DAY OF September, 2018.

NOTARY PUBLIC IN AND FOR THE STATE OF TEXAS

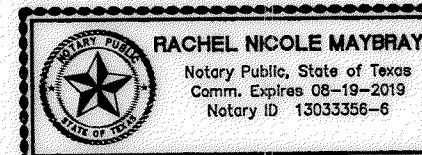

IN TESTIMONY WHEREOF, SIENNA PLANTATION LEVEE IMPROVEMENT DISTRICT, HAS CAUSED THESE PRESENTS TO BE SIGNED BY KEN BECKMAN, ITS PRESIDENT, THEREUNTO AUTHORIZED, THIS 5<sup>th</sup> DAY OF October, 2018.

SIENNA PLANTATION LEVEE IMPROVEMENT DISTRICT

BY: Ken Beckman  
KEN BECKMAN, PRESIDENT

STATE OF TEXAS  
COUNTY OF HARRIS

BEFORE ME, THE UNDERSIGNED AUTHORITY, ON THIS DAY PERSONALLY APPEARED KEN BECKMAN, PRESIDENT OF SIENNA PLANTATION LEVEE IMPROVEMENT DISTRICT, KNOWN TO ME TO BE THE PERSON WHOSE NAME IS SUBSCRIBED TO THE FOREGOING INSTRUMENT AND ACKNOWLEDGED TO ME THAT HE EXECUTED THE SAME FOR THE PURPOSES AND CONSIDERATIONS THEREIN EXPRESSED AND IN THE CAPACITY THEREIN AND HEREIN SET OUT.

GIVEN UNDER MY HAND AND SEAL OF OFFICE, THIS 5<sup>th</sup> DAY OF October, 2018.

NOTARY PUBLIC IN AND FOR THE STATE OF TEXAS



I, JON P. BORDOVSKY, A REGISTERED PROFESSIONAL LAND SURVEYOR, AM AUTHORIZED UNDER THE LAWS OF THE STATE OF TEXAS TO PRACTICE THE PROFESSION OF LAND SURVEYING AND HEREBY CERTIFY THAT THE ABOVE SUBDIVISION IS TRUE AND CORRECT, WAS PREPARED FROM AN ACTUAL SURVEY OF THE PROPERTY MADE UNDER MY SUPERVISION ON THE GROUND AND THAT ALL BOUNDARY CORNERS, ANGLES, POINTS OF CURVATURE AND OTHER POINTS OF REFERENCE HAVE BEEN MARKED WITH IRON (OR OTHER SUITABLE PERMANENT METAL) PIPES OR RODS HAVING AN OUTSIDE DIAMETER OF NOT LESS THAN FIVE-EIGHTHS (5/8) INCH WITH PLASTIC CAP MARKED "GBI PARTNERS" AND A LENGTH OF NOT LESS THAN THREE (3) FEET.

BY: J. P. Bordovsky  
JON P. BORDOVSKY, R.P.L.S.  
REGISTERED PROFESSIONAL LAND SURVEYOR  
TEXAS REGISTRATION NO. 6405

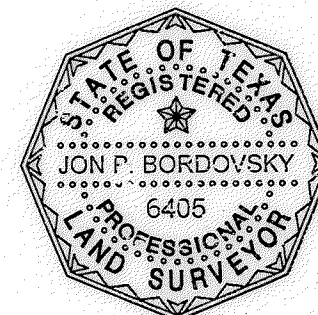

I, AMANDA CARRIAGE, A PROFESSIONAL ENGINEER REGISTERED IN THE STATE OF TEXAS DO HEREBY CERTIFY THAT THIS PLAT MEETS ALL REQUIREMENTS OF FORT BEND COUNTY TO THE BEST OF MY KNOWLEDGE.

BY: Amanda Carriage  
AMANDA CARRIAGE, P.E.  
LICENSED PROFESSIONAL ENGINEER  
TEXAS LICENSE NO. 105912



STATE OF TEXAS  
COUNTY OF FORT BEND

THIS IS TO CERTIFY THAT THE PLANNING AND ZONING COMMISSION OF THE CITY OF MISSOURI CITY, TEXAS, HAS APPROVED THIS PLANNING AND SUBDIVISION OF SIENNA PLANTATION SECTION 14 IN CONFORMANCE WITH THE LAWS OF THE STATE OF TEXAS AND THE ORDINANCES OF THE CITY OF MISSOURI CITY AS SHOWN HEREON AND AUTHORIZED THE RECORDING OF THIS PLAT

THIS 10<sup>th</sup> DAY OF October, 2018.

BY: Sonya Brown  
SONYA BROWN-MARSHALL, CHAIRMAN

BY: Timothy R. Haney  
TIMOTHY R. HANEY, VICE CHAIRMAN

NOTES:

- BENCHMARK: FOUND 4 INCH BRASS DISC LOCATED IN A POURED CONCRETE POST IN THE GRASSY AREA IN FRONT OF MISSOURI CITY FIRE STATION NUMBER 5 18.5 FEET FROM THE SIDE WALK. SURVEY MARKER NO. PCM-0111 ELEV. = 59.97 (NAVD83 2001 ADJUSTMENT)
- T.B.M. INDICATES TEMPORARY BENCHMARK. FND. 5/8 INCH IRON ROD WITH CAP MARKED "LJA ENG" ELEV. = 53.75 2001 ADJUSTMENT
- ALL BEARINGS REFERENCED TO THE TEXAS COORDINATE SYSTEM, SOUTH CENTRAL ZONE (NAD83). COORDINATES SHOWN ARE GRID AND MAY BE CONVERTED TO SURFACE BY DIVIDING BY A FACTOR OF 0.999867651.
- THIS PLAT WAS PREPARED TO MEET CITY OF MISSOURI CITY AND FORT BEND COUNTY REQUIREMENTS.
- THIS PLAT WAS PREPARED FROM INFORMATION FURNISHED BY STEWART TITLE COMPANY, FILE NO. 1790313CPL DATED AUGUST 7, 2018. THE SURVEYOR HAS NOT ABSTRACTED THE ABOVE PROPERTY.
- THIS PLAT LIES WHOLLY WITHIN SIENNA PLANTATION LEVEE IMPROVEMENT DISTRICT, FORT BEND SUBSIDENCE DISTRICT, FORT BEND COUNTY DRAINAGE DISTRICT, THE ETJ OF THE CITY OF MISSOURI CITY AND FORT BEND COUNTY, AND PARTIALLY WITHIN SIENNA PLANTATION MUNICIPAL UTILITY DISTRICT NO. 4 AND SIENNA PLANTATION MUNICIPAL UTILITY DISTRICT NO. 6.
- IN ACCORDANCE WITH FEDERAL EMERGENCY MANAGEMENT AGENCY FLOOD INSURANCE RATE MAP, MAP NO. 48157C 0435L, REVISED DATE APRIL 2, 2014, PROPERTY LIES WITHIN SHADED ZONE "X" DEFINED AS AREAS OF 0.2% ANNUAL CHANCE FLOOD. THIS AREA IS SHOWN AS BEING PROTECTED FROM THE 1% ANNUAL CHANCE OR GREATER FLOOD HAZARD BY A LEVEE SYSTEM. OVERTOPPING OR FAILURE OF ANY LEVEE SYSTEM IS POSSIBLE. LJA DOES NOT WARRANT NOR SUBSCRIBE TO THE ACCURACY OR SCALE OF SAID MAPS.
- THERE ARE NO EXISTING OR PROPOSED PIPELINE EASEMENTS WITHIN THE LIMITS OF THE SUBDIVISION.
- FIVE EIGHTHS INCH (5/8") IRON RODS THREE FEET (3') IN LENGTH WITH A PLASTIC CAP MARKED "GBI PARTNERS" WILL BE SET ON ALL PERIMETER BOUNDARY CORNERS. LOT, BLOCK, AND RESERVE CORNERS WILL BE SET UPON COMPLETION OF ROAD CONSTRUCTION AND PRIOR TO LOT CONSTRUCTION.
- THE TOP OF ALL FLOOR SLABS SHALL BE A MINIMUM OF 56.99 FEET ABOVE MEAN SEA LEVEL. FEMA REGULATIONS SECTION 82-97(11) REQUIRES THE MINIMUM SLAB ELEVATION SHALL BE SET ONE FOOT ABOVE THE 100-YEAR FLOOD ELEVATION. THE CITY OF MISSOURI CITY CODE OF ORDINANCES SECTION 42, ARTICLE III REQUIRES THE MINIMUM SLAB ELEVATION SHALL BE ELEVATED TO OR ABOVE A HEIGHT WHICH IS HIGHER OF EIGHTEEN INCHES ABOVE HIGHEST ADJACENT GRADE, OR TWELVE INCHES ABOVE THE MAXIMUM ONE PERCENT ANNUAL FLOOD RISK FLOODPLAIN PONDING ELEVATION IN THE NEAREST DRAINAGE SYSTEM. FORT BEND COUNTY FLOODPLAIN REGULATIONS ARTICLE 5, SECTION B REQUIRES THAT THE MINIMUM SLAB BE SET AT AN ELEVATION EIGHTEEN INCHES ABOVE THE BASE FLOOD ELEVATION WHICH IS MORE STRINGENT AND THEREFORE USED TO DETERMINE THE MINIMUM SLAB ELEVATION. THE TOP OF SLAB ELEVATION AT ANY POINT ON THE PERIMETER OF THE SLAB SHALL NOT BE LESS THAN EIGHTEEN (18) INCHES ABOVE NATURAL GROUND.
- ALL DRAINAGE AND FLOODWAY EASEMENTS SHALL BE KEPT CLEAR OF FENCES, BUILDINGS, PLANTINGS AND OTHER OBSTRUCTIONS TO THE OPERATIONS AND MAINTENANCE OF THE DRAINAGE FACILITY AS REQUIRED BY SUBSECTION 82-168(D) OF THE CODE OF ORDINANCES OF THE CITY OF MISSOURI CITY, TEXAS.
- THE DRAINAGE SYSTEM FOR THIS SUBDIVISION SHALL BE DESIGNED TO MEET THE REQUIREMENTS OF THE FORT BEND COUNTY DRAINAGE CRITERIA MANUAL WHICH ALLOWS STREET PONDING DURING INTENSE RAINFALL EVENTS.
- ALL PROPERTY TO DRAIN INTO THE DRAINAGE EASEMENT ONLY THROUGH AN APPROVED DRAINAGE STRUCTURE.
- A MINIMUM DISTANCE OF 10' SHALL BE MAINTAINED BETWEEN RESIDENTIAL STRUCTURES.
- THE CITY OF MISSOURI CITY SHALL NOT BE RESPONSIBLE FOR MAINTENANCE OF DRIVEWAYS, SIDEWALKS, EMERGENCY ACCESS EASEMENTS, RECREATIONAL AREAS, OPEN SPACE AND RESERVES.
- SIDEWALKS SHALL BE BUILT OR CAUSED TO BE BUILT NOT LESS THAN 5- FEET IN WIDTH ON BOTH SIDES OF ALL DEDICATED RIGHTS-OF-WAY WITHIN SAID PLAT AND ON CONTIGUOUS RIGHT-OF-WAY OF ALL PERIMETER ROADS SURROUNDING SAID PLAT, IN ACCORDANCE WITH ADA REQUIREMENTS.
- SIDEWALKS SHALL BE CONSTRUCTED AS REQUIRED BY SECTION 82-164 OR THE CODE OF ORDINANCES OF THE CITY OF MISSOURI CITY, TEXAS.
- DRIVEWAY APPROACHES SHALL BE PROVIDED IN ACCORDANCE WITH THE MISSOURI CITY DRIVEWAY APPROACH POLICY AS REQUIRED UNDER THE PROVISIONS OF SUBSECTION 82-160 OF THE CODE OF ORDINANCES OF THE CITY OF MISSOURI CITY, TEXAS.
- IN ACCORDANCE WITH CENTER POINT ENERGY ELECTRICAL SERVICE MANUAL, ARTICLE 421-2, ELECTRIC METERS SHALL BE LOCATED IN A POSITION THAT IS ACCESSIBLE AT ALL TIMES WITHOUT CUSTOMER ASSISTANCE. ACCESS TO THE METER SHALL NOT BE BLOCKED BY GATES, WALLS OR FENCES.
- ALL REQUIRED UTILITY COMPANIES HAVE BEEN CONTACTED AND ALL PUBLIC UTILITY EASEMENTS AS SHOWN ON THE ABOVE AND FOREGOING PLAT CONSTITUTE ALL OF THE EASEMENTS REQUIRED BY THE UTILITY COMPANIES CONTACTED AT THE TIME OF PLATTING.
- GAS METER LOCATION: GAS METERS SHALL BE LOCATED IN AN AREA ACCESSIBLE WITHOUT CUSTOMER ASSISTANCE, AND NOT BLOCKED BY FENCES, WALLS OR GATES. FOR FURTHER INFORMATION PLEASE CONTACT SENERGY AT 281-778-6250.
- ALL OF THE PROPERTY SUBDIVIDED IN THE ABOVE AND FOREGOING PLAT IS WITHIN THE ETJ BOUNDARIES OF THE CITY OF MISSOURI CITY, TEXAS.
- NO BUILDING OR OTHER PERMIT, EXCEPT PERMITS FOR CONSTRUCTION OF PUBLIC IMPROVEMENTS WILL BE ISSUED BY THE CITY OF MISSOURI CITY, TEXAS, FOR CONSTRUCTION WITHIN THIS SUBDIVISION UNTIL SUCH TIME AS ALL PUBLIC IMPROVEMENTS OF THE SUBDIVISION HAVE BEEN CONSTRUCTED BY THE DEVELOPER AND ACCEPTED BY THE CITY OR THE GUARANTEE OF CONSTRUCTION OF PUBLIC IMPROVEMENTS REQUIRED BY SECTION 82-209 OF THE CODE OF ORDINANCES OF THE CITY OF MISSOURI CITY, TEXAS, IS SUBMITTED TO AND APPROVED BY THE CITY.
- PRIOR TO THE BEGINNING OF THE ONE-YEAR MAINTENANCE PERIOD FOR UTILITIES AND PAVING BY FORT BEND COUNTY. ALL BLOCK CORNERS AND STREET RIGHT-OF-WAY WILL BE MONUMENTED.
- ADEQUATE FIRE FLOWS SHALL BE PROVIDED ALONG THE ENTIRE LENGTH OF THE PROPOSED WATER LINE.
- REQUIRED FIRE FLOWS SHALL BE PROVIDED BASED ON THE SIZE AND CONSTRUCTION OF ALL BUILDINGS AS REQUIRED BY THE INTERNATIONAL FIRE CODE AS ADOPTED BY THE CITY.
- THE PLACEMENT OF FIRE HYDRANTS SHALL BE PROVIDED BASED ON THE MINIMUM DISTANCE REQUIREMENTS AS ESTABLISHED IN THE INTERNATIONAL FIRE CODE AS ADOPTED BY THE CITY (500FT. FOR RESIDENTIAL DEVELOPMENT AND 300FT. FOR COMMERCIAL DEVELOPMENT). ALL FIRE HYDRANTS SHALL BE INSTALLED ACCORDING TO THE INTERNATIONAL FIRE CODE AS ADOPTED BY THE CITY.
- THE DRIVEWAY FOR ANY LOT ON THE INSIDE OF A KNUCKLE MUST BE PLACED ALONG THE FRONTAGE PRIOR TO THE RIGHT TURN ON THE INSIDE APPROACH LANE TO AVOID SIGHT OBSTRUCTION SAFETY HAZARDS.
- STREET LIGHTING SHALL BE DESIGNED AND INSTALLED IN ACCORDANCE WITH THE CITY OF MISSOURI CITY INFRASTRUCTURE DESIGN MANUAL, CHAPTER 4 STREET LIGHTING AND OVERHEAD UTILITIES. THE INSTALLATION, OPERATION, AND MAINTENANCE OF ORNAMENTAL STREET LIGHTS SHALL NOT BE THE RESPONSIBILITY OF THE CITY OF MISSOURI CITY, EXCEPT AS PROVIDED THEREIN.
- OWNERSHIP AND MAINTENANCE RESPONSIBILITY OF THE DRAINAGE RESERVES AND CHANNELS IS VESTED IN THE SIENNA PLANTATION LEVEE IMPROVEMENT DISTRICT. THE OWNERSHIP AND MAINTENANCE RESPONSIBILITY OF LANDSCAPE RESERVES IS VESTED IN THE SIENNA PLANTATION MUNICIPAL UTILITY DISTRICT NO. 5.
- OWNERSHIP AND MAINTENANCE RESPONSIBILITY OF THE UTILITIES WITHIN THE SECTIONS IS VESTED IN SIENNA PLANTATION MUNICIPAL UTILITY DISTRICT NO. 4. THE OWNERSHIP AND MAINTENANCE RESPONSIBILITY OF THE UTILITIES ALONG BOULEVARDS AND MAJOR THOROUGHFARES IS VESTED IN THE SIENNA PLANTATION MUNICIPAL UTILITY DISTRICT NO. 5.
- THIS PLAT IS SUBORDINATED BY: U.S. BANK NATIONAL ASSOCIATION D/B/A HOUSING CAPITAL COMPANY, AS RECORDED IN FILE NO. \_\_\_\_\_ OF THE OFFICIAL RECORDS OF FORT BEND COUNTY, TEXAS.
- THIS PLAT LIES WITHIN LIGHTING ZONE 2.
- THIS PLAT IS SUBJECT TO OVER AND ACROSS EASEMENTS AS SET FORTH BY THE RESTRICTED COVENANTS RECORDED UNDER FILE NO. 2015009259, F.B.C.O.R.
- ONE-FOOT RESERVE DEDICATED TO THE CITY IN FEE AS A BUFFER SEPARATION BETWEEN THE SIDE OR END OF STREETS WHERE SUCH STREETS ADJACENT ACREAGE TRACTS, THE CONDITION OF SUCH DEDICATION BEING THAT WHEN THE ADJACENT PROPERTY IS SUBDIVIDED PURSUANT TO A RECORDED PLAT, THE ONE-FOOT RESERVE SHALL THEREUPON BECOME VESTED IN THE PUBLIC FOR STREET RIGHT-OF-WAY PURPOSES AND THE FEE TITLE THERETO SHALL REVERT TO AND REVEST IN THE DEDICATOR, HIS HEIRS, ASSIGNS OR SUCCESSORS.
- U.V.E. INDICATES UNOBSTRUCTED VIEW EASEMENT. FORT BEND COUNTY SHALL BE RESPONSIBLE FOR ENFORCING U.V.E. REQUIREMENTS WITHIN THE PUBLIC RIGHT-OF-WAY AND SIENNA PLANTATION COMMUNITY ASSOCIATION, INC. SHALL ENFORCE AREAS OUTSIDE OF RIGHT-OF-WAY.
- SITE PLANS SHALL BE SUBMITTED TO FORT BEND COUNTY AND ANY OTHER APPLICABLE JURISDICTIONS FOR REVIEW AND APPROVAL. DEVELOPMENT PERMITS AND ALL OTHER APPLICABLE PERMITS SHALL BE OBTAINED FROM FORT BEND COUNTY PRIOR TO BEGINNING CONSTRUCTION.

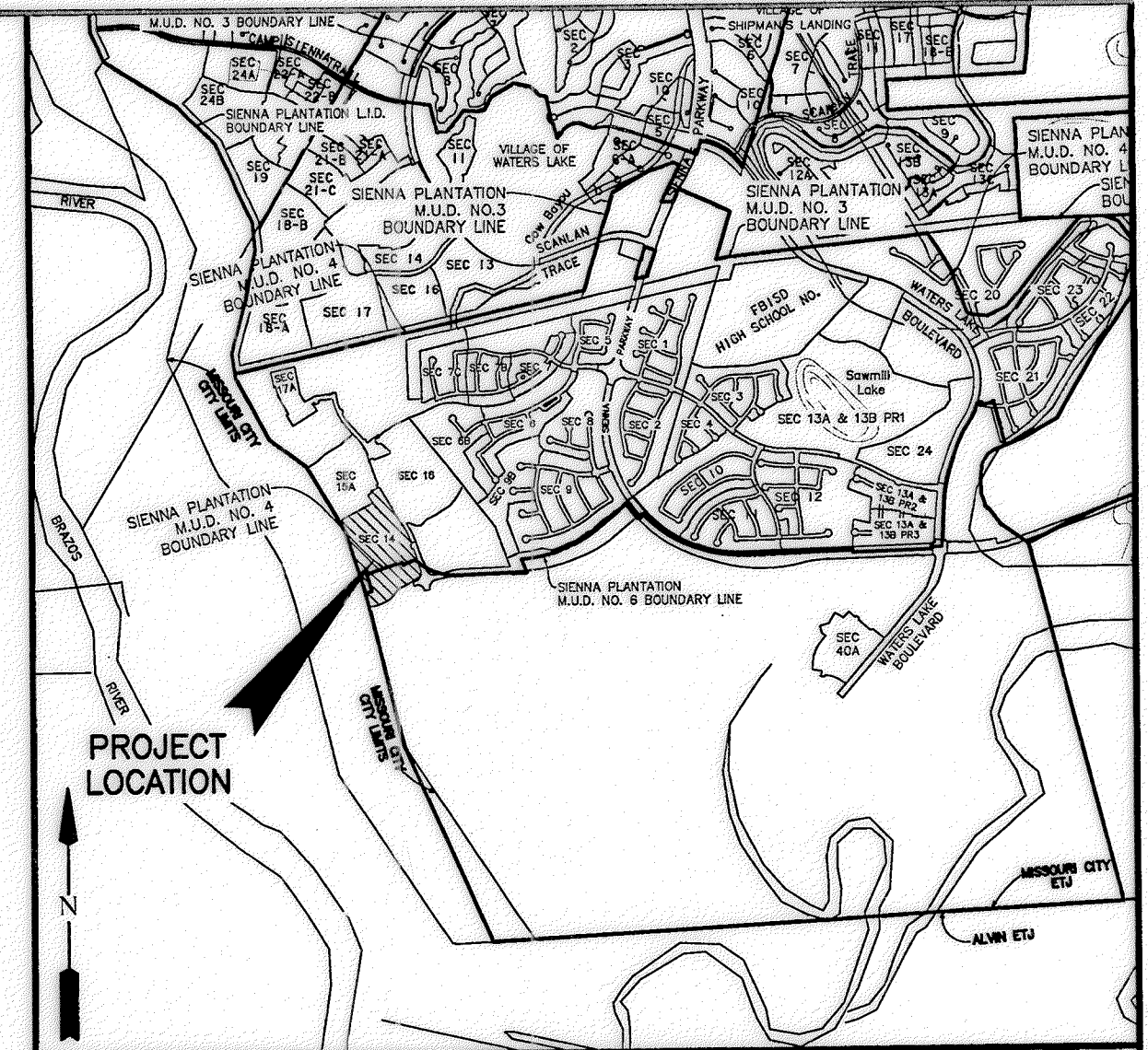

VICINITY MAP  
SCALE: 1"=1/2 MILE  
KEY MAP NO. 650T

I, RICHARD W. STOLLEIS, FORT BEND COUNTY ENGINEER, DO HEREBY CERTIFY THAT THE PLAT OF THIS SUBDIVISION COMPLIES WITH ALL OF THE EXISTING RULES AND REGULATIONS OF THIS OFFICE AS ADOPTED BY THE FORT BEND COUNTY COMMISSIONERS' COURT. HOWEVER, NO CERTIFICATION IS HEREBY GIVEN AS TO THE EFFECT OF DRAINAGE FROM THIS SUBDIVISION ON THE INTERCEPTING DRAINAGE ARTERY OR PARENT STREAM OR ON ANY OTHER AREA OR SUBDIVISION WITHIN THE WATERSHED.

RICHARD W. STOLLEIS, P.E.  
FORT BEND COUNTY ENGINEER

APPROVED BY THE COMMISSIONERS' COURT OF FORT BEND COUNTY, TEXAS.  
THIS \_\_\_\_\_ DAY OF \_\_\_\_\_, 2018.

VINCENT M. MORALES, JR.  
PRECINCT 1, COUNTY COMMISSIONER

GHADY PRESTAGE  
PRECINCT 2, COUNTY COMMISSIONER

ROBERT E. HEBERT  
COUNTY JUDGE

W. A. (ANDY) MEYERS  
PRECINCT 3, COUNTY COMMISSIONER

JAMES PATTERSON  
PRECINCT 4, COUNTY COMMISSIONER

I, LAURA RICHARD, COUNTY CLERK IN AND FOR FORT BEND COUNTY, HEREBY CERTIFY THAT THE FOREGOING INSTRUMENT WITH ITS CERTIFICATE OF AUTHENTICATION WAS FILED FOR RECORDATION IN MY OFFICE ON \_\_\_\_\_, 2018 AT \_\_\_\_\_ O'CLOCK \_\_\_\_\_M. IN PLAT NUMBER \_\_\_\_\_ OF THE PLAT RECORDS OF FORT BEND COUNTY, TEXAS.

WITNESS MY HAND AND SEAL OF OFFICE, AT RICHMOND, TEXAS, THE DAY AND DATE LAST ABOVE WRITTEN.

LAURA RICHARD, COUNTY CLERK  
FORT BEND COUNTY, TEXAS

BY: \_\_\_\_\_  
DEPUTY

### SIENNA PLANTATION SECTION 14

A SUBDIVISION OF 27.144 ACRES OF LAND SITUATED IN THE  
DAVID FITZGERALD LEAGUE, ABSTRACT 25, AND IN THE WILLIAM HALL  
LEAGUE, ABSTRACT 31, FORT BEND COUNTY, TEXAS.

100 LOTS 6 RESERVES (5.992 ACRES) 4 BLOCKS  
SEPTEMBER 24, 2018 JOB NO. 1414-1514P

OWNERS:  
TOLL-GTIS PROPERTY OWNER, LLC  
JIMMIE F. JENKINS, AUTHORIZED REPRESENTATIVE  
10110 WEST SAM HOUSTON PARKWAY NORTH, SUITE 210, HOUSTON, TEXAS 77064  
PH. (281) 894-8655

SIENNA PLANTATION LEVEE IMPROVEMENT DISTRICT  
KEN BECKMAN, PRESIDENT  
202 CENTURY SQUARE BLVD., SUGAR LAND, TEXAS 77478  
PH. (281) 500-6050

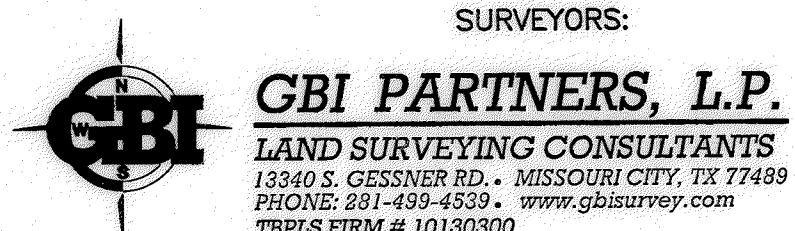

ENGINEER:  
LJA Engineering, Inc.  
1904 W. Grand Parkway North  
Suite 100  
Katy, Texas 77449  
Phone 713.953.5200  
Fax 713.953.5026  
FRN-1386

CURVE	RADIUS	DELTA	ARC	CHORD	CHORD BEARING
C1	25.00'	94°28'39"	41.22'	35.71'	N 16°39'36" E
C2	25.00'	85°28'58"	37.30'	33.93'	S 73°21'36" E
C3	700.00'	0°45'51"	9.34'	9.34'	S 31°00'02" E
C4	1770.00'	9°23'35"	290.17'	288.85'	S 26°41'10" E
C5	1830.00'	2°27'29"	78.51'	78.50'	S 20°45'38" E
C6	800.00'	4°09'32"	43.55'	43.54'	S 17°27'08" E
C7	800.00'	4°09'32"	43.55'	43.54'	S 17°27'08" E
C8	760.00'	3°56'53"	52.37'	52.36'	S 17°33'28" E
C9	100.00'	50°10'24"	87.57'	84.80'	S 09°30'11" W
C10	100.00'	4°19'56"	7.56'	7.56'	S 22°52'25" W
C11	642.00'	20°32'31"	230.17'	228.94'	S 65°46'54" W
C12	1800.00'	1°00'58"	31.92'	31.92'	S 31°05'09" E
C13	500.00'	8°34'51"	74.88'	74.81'	N 27°18'12" W
C14	2000.00'	6°03'13"	211.31'	211.21'	N 19°58'10" W
C15	50.00'	89°00'47"	77.68'	70.10'	N 27°32'50" E
C16	50.00'	90°00'00"	78.54'	70.71'	N 27°03'13" W
C17	1000.00'	3°00'42"	52.56'	52.56'	N 70°32'53" E
C18	50.00'	90°00'00"	78.54'	70.71'	S 62°56'47" E
C19	550.00'	7°05'48"	68.12'	68.08'	N 21°29'40" W
C20	50.00'	88°26'57"	77.19'	69.75'	S 19°10'54" W
C21	800.00'	9°04'00"	70.75'	70.72'	N 69°31'13" E
C22	450.00'	9°48'53"	77.08'	76.99'	N 62°04'47" E
C23	1800.00'	2°27'29"	77.22'	77.21'	N 20°49'38" W
C24	1775.00'	1°00'58"	31.48'	31.48'	S 31°05'09" E
C25	525.00'	8°34'51"	78.62'	78.55'	S 27°18'12" E
C26	2025.00'	2°42'28"	95.71'	95.70'	S 21°39'33" E
C27	25.00'	90°30'10"	39.55'	35.58'	S 69°37'53" E
C28	25.00'	91°01'54"	39.72'	35.67'	N 23°31'34" E
C29	25.00'	91°29'34"	39.89'	35.79'	N 65°14'41" W
C30	25.00'	86°16'46"	37.63'	34.19'	S 25°54'09" W
C31	2030.00'	0°16'40"	9.84'	9.84'	S 17°05'54" E
C32	25.00'	33°57'44"	14.82'	14.62'	S 33°56'28" E
C33	50.00'	134°47'54"	117.63'	92.32'	S 16°28'39" W
C34	25.00'	11°49'23"	5.16'	5.15'	S 77°57'55" W
C35	25.00'	90°00'00"	39.27'	35.36'	S 27°03'13" W
C36	50.00'	180°00'00"	197.08'	100.00'	S 72°03'13" W
C37	25.00'	185°33'44"	7.40'	7.37'	N 26°25'33" W
C38	50.00'	136°14'10"	118.89'	92.80'	N 33°12'45" E
C39	25.00'	29°16'36"	12.77'	12.64'	N 86°41'31" E
C40	25.00'	89°00'47"	38.84'	35.05'	N 27°32'50" E
C41	1970.00'	0°12'53"	7.38'	7.38'	N 17°04'00" W
C42	25.00'	93°47'02"	40.92'	36.50'	N 64°03'58" W
C43	1025.00'	3°00'42"	53.88'	53.67'	S 70°32'53" W
C44	25.00'	30°15'03"	13.20'	13.05'	S 56°59'42" W
C45	50.00'	150°55'48"	131.71'	96.80'	N 62°43'59" W
C46	25.00'	30°40'46"	13.39'	13.23'	N 02°36'24" W
C47	525.00'	6°40'26"	61.15'	61.12'	N 21°16'59" W
C48	25.00'	31°26'46"	13.72'	13.55'	N 40°20'36" W
C49	50.00'	150°46'40"	131.58'	96.77'	N 19°19'22" E
C50	25.00'	31°18'19"	13.66'	13.49'	N 79°03'32" E
C51	25.00'	94°28'50"	41.21'	36.70'	N 16°10'57" E
C52	1825.00'	0°27'49"	14.76'	14.76'	N 30°48'34" W
C53	25.00'	88°26'57"	38.59'	34.87'	N 19°10'54" W
C54	25.00'	85°00'00"	37.09'	33.78'	S 74°03'39" E
C55	25.00'	90°47'01"	41.79'	37.09'	S 16°17'53" W
C56	425.00'	2°47'49"	20.75'	20.75'	S 69°35'18" W
C57	775.00'	5°04'00"	68.53'	68.51'	S 69°31'13" W
C58	25.00'	90°00'00"	39.27'	35.36'	N 62°56'47" W
C59	575.00'	7°05'48"	71.22'	71.17'	N 21°29'40" W
C60	25.00'	90°00'00"	39.27'	35.36'	N 27°03'13" E
C61	825.00'	5°04'00"	72.96'	72.93'	N 69°31'13" E
C62	475.00'	3°49'54"	31.77'	31.76'	N 65°04'16" E
C63	25.00'	89°14'06"	38.94'	35.12'	S 72°13'38" E
C64	475.00'	4°35'48"	38.11'	38.10'	S 25°18'41" E
C65	1975.00'	2°35'18"	99.56'	99.55'	S 21°34'08" E
C66	25.00'	89°10'01"	38.91'	35.10'	S 24°27'31" W
C67	975.00'	3°00'42"	51.25'	51.24'	S 70°32'53" W
C68	25.00'	90°00'00"	39.27'	35.36'	N 62°56'47" W
C69	692.00'	4°59'10"	60.22'	60.20'	N 59°45'39" E
C70	682.00'	4°59'10"	59.35'	59.33'	S 56°45'39" W
C71	652.00'	2°47'34"	31.78'	31.78'	S 55°39'51" W
C72	642.00'	0°24'19"	4.54'	4.54'	N 59°18'29" E
C73	692.00'	7°05'11"	85.59'	85.53'	N 57°48'39" E
C74	642.00'	7°05'11"	79.40'	79.35'	S 57°48'39" W
C75	15.00'	89°31'25"	22.39'	20.37'	N 73°20'22" W
C76	10.00'	87°20'06"	15.24'	13.81'	N 20°13'52" E
C77	25.00'	92°39'54"	40.43'	36.17'	S 69°46'08" E

LINE	BEARING	DISTANCE
L1	N 59°25'21" E	50.00'
L2	N 63°53'55" E	101.81'
L3	N 68°00'37" E	60.00'
L4	S 19°31'54" E	83.10'
L5	S 70°28'06" W	60.00'
L6	S 19°31'54" E	16.83'
L7	S 19°22'22" E	94.31'
L8	S 19°31'54" E	19.88'
L9	S 57°17'14" W	147.60'
L10	S 62°01'11" W	198.95'
L11	S 40°47'23" W	205.31'
L12	S 76°03'10" W	118.97'
L13	S 23°00'47" E	79.57'
L14	S 17°56'47" E	161.06'
L15	N 74°57'10" W	13.50'
L16	N 65°59'13" E	99.10'
L17	S 19°31'54" E	83.10'

LINE	BEARING	DISTANCE
L18	S 23°00'47" E	79.57'
L19	N 69°02'32" E	115.71'
L20	N 19°31'54" W	47.95'
L21	S 69°02'32" E	113.78'
L22	S 17°56'47" E	161.06'
L23	N 17°56'47" W	173.77'
L24	S 69°02'32" E	41.91'
L25	S 69°59'13" W	99.10'
L26	S 72°03'13" W	71.35'
L27	N 72°03'13" E	71.35'
L28	N 69°59'13" E	99.10'
L29	S 23°00'47" E	79.57'
L30	S 69°02'32" W	50.95'
L31	N 69°02'32" E	110.13'
L32	N 24°06'34" E	14.16'
L33	S 73°20'46" E	14.70'
L34	N 63°53'42" E	107.61'

LINE	BEARING	DISTANCE
L35	N 60°59'47" W	13.64'
L36	S 29°56'19" W	25.00'
L37	S 67°57'48" E	12.85'
L38	N 56°58'20" E	84.03'
L39	N 22°00'46" E	93.07'
L40	N 00°21'30" E	52.07'
L41	N 19°31'54" W	75.30'
L42	S 68°04'57" E	13.75'
L43	N 23°28'10" W	9.65'
L44	S 23°28'10" E	5.00'
L45	S 16°57'34" E	133.85'
L46	S 39°39'41" E	38.02'
L47	S 30°44'46" E	10.00'
L48	S 80°05'50" E	35.03'
L49	S 63°53'55" W	15.98'
L50	N 63°53'55" E	14.09'
L51	N 26°06'05" W	5.00'

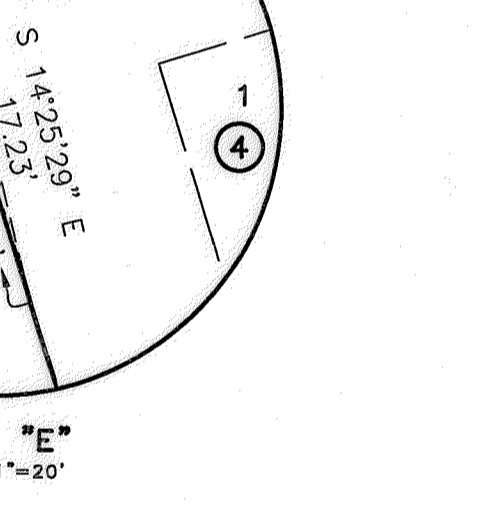
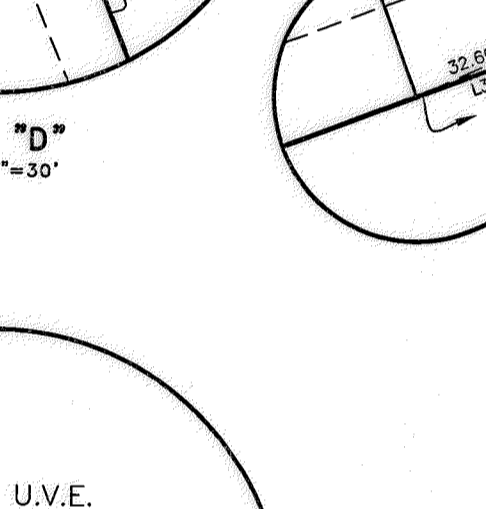
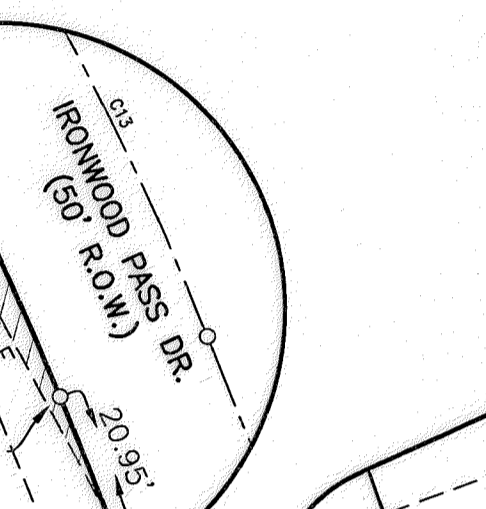
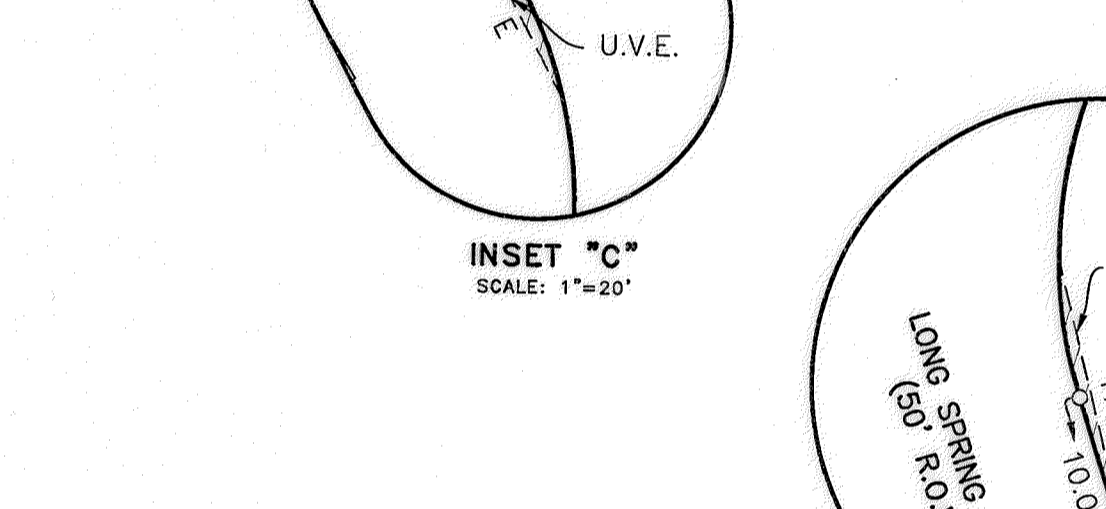
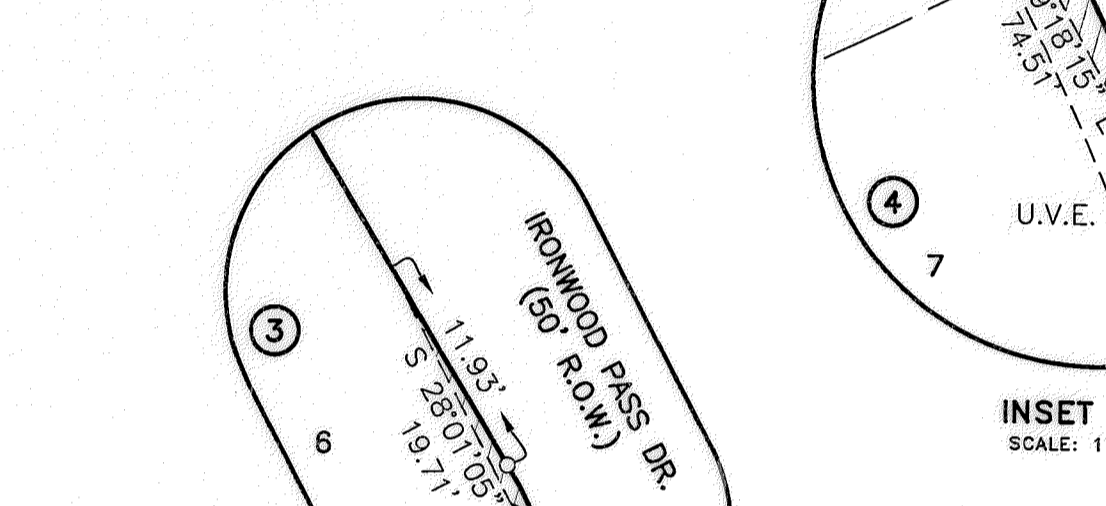
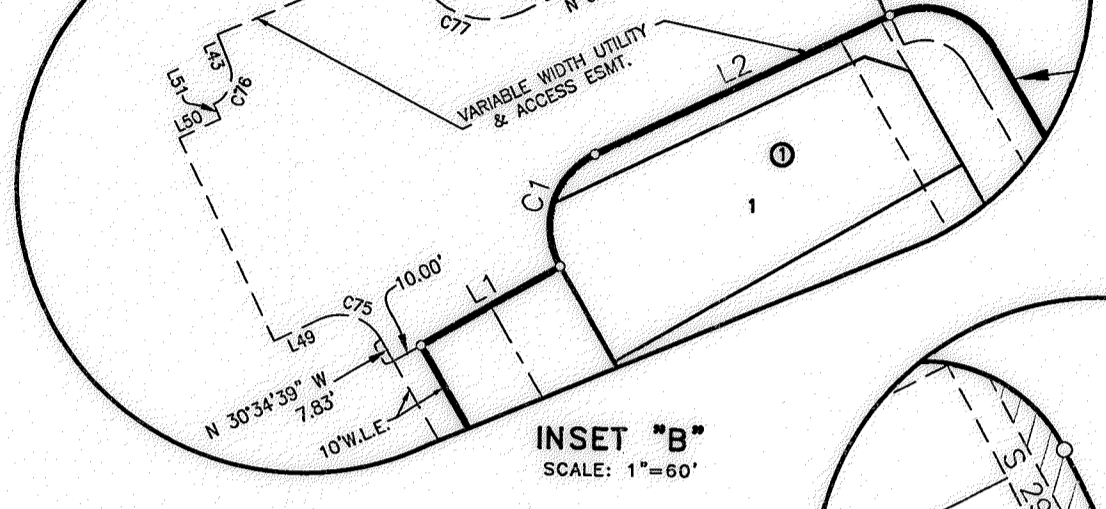
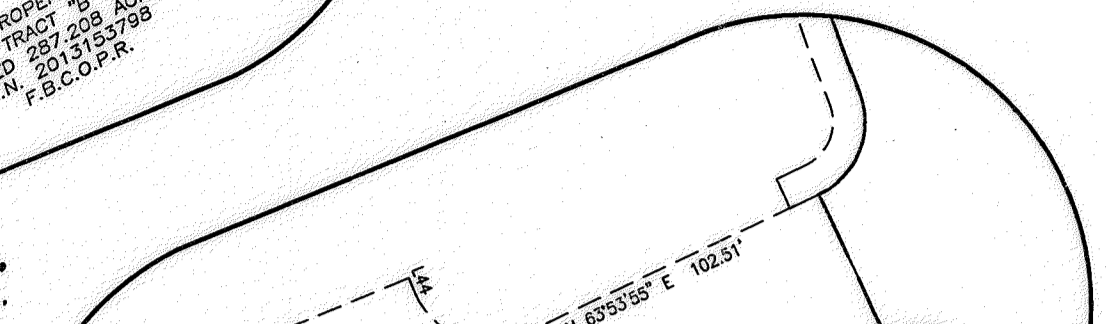
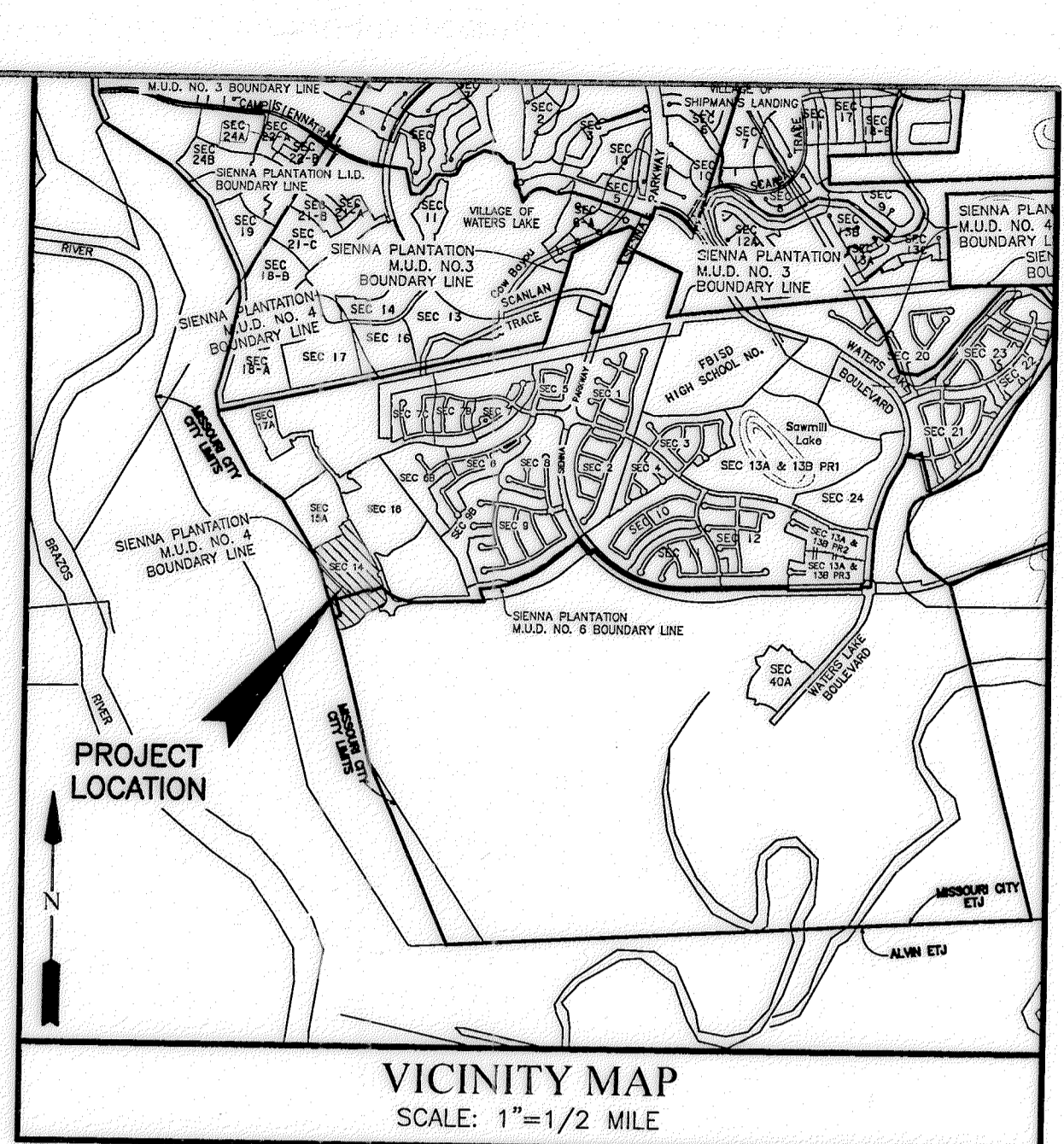
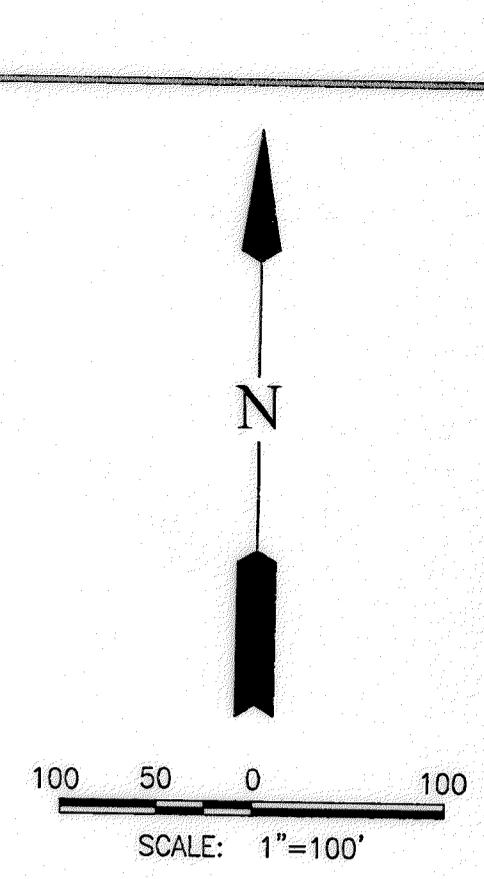
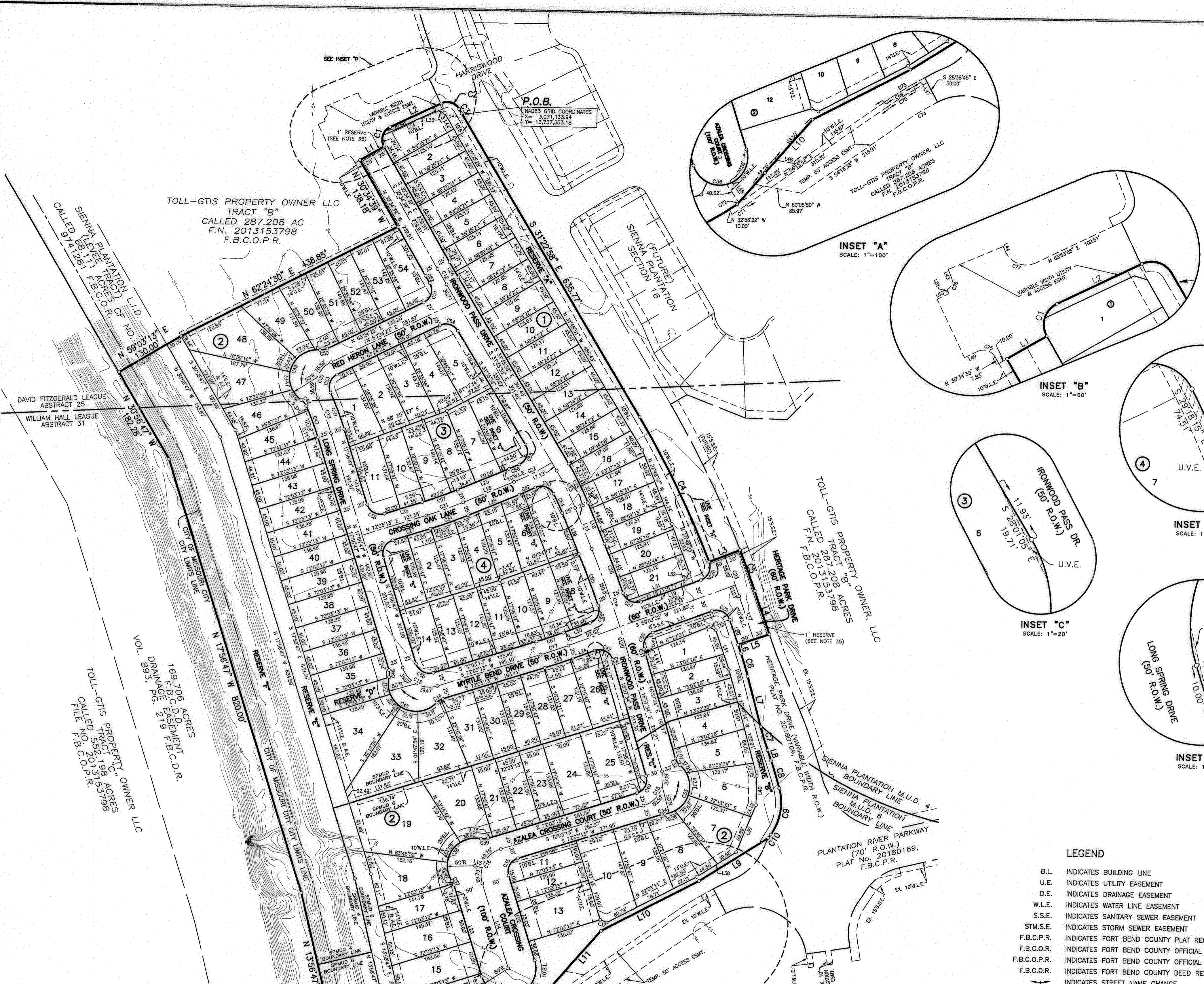

- LEGEND**
- B.L. INDICATES BUILDING LINE
  - U.E. INDICATES UTILITY EASEMENT
  - D.E. INDICATES DRAINAGE EASEMENT
  - W.L.E. INDICATES WATER LINE EASEMENT
  - S.S.E. INDICATES SANITARY SEWER EASEMENT
  - STM.S.E. INDICATES STORM SEWER EASEMENT
  - F.B.C.P.R. INDICATES FORT BEND COUNTY PLAT RECORDS
  - F.B.C.O.R. INDICATES FORT BEND COUNTY OFFICIAL RECORDS
  - F.B.C.P.P.R. INDICATES FORT BEND COUNTY OFFICIAL PUBLIC RECORDS
  - F.B.C.D.R. INDICATES FORT BEND COUNTY DEED RECORDS
  - INDICATES STREET NAME CHANGE
  - F.N. INDICATES FILE NUMBER
  - S.N. INDICATES SEE NOTE
  - RES. INDICATES RESERVE
  - V.A.M. INDICATES VISIBILITY ACCESS & MAINTENANCE EASEMENT
  - E.E. INDICATES ELECTRICAL EASEMENT

**SIENNA PLANTATION SECTION 14**

A SUBDIVISION OF 27.144 ACRES OF LAND SITUATED IN THE DAVID FITZGERALD LEAGUE, ABSTRACT 25, AND IN THE WILLIAM HALL LEAGUE, ABSTRACT 31, FORT BEND COUNTY, TEXAS.  
100 LOTS 6 RESERVES (5.992 ACRES) 4 BLOCKS

SEPTEMBER 24, 2018 JOB NO. 1414-1514P

OWNERS:  
**TOLL-GTIS PROPERTY OWNER, LLC**  
JIMMIE F. JENKINS, AUTHORIZED REPRESENTATIVE  
10110 WEST SAM HOUSTON PARKWAY NORTH, SUITE 210, HOUSTON, TEXAS 77064  
PH. (281) 894-8655

**SIENNA PLANTATION LEVEE IMPROVEMENT DISTRICT**  
KEN BECKMAN, PRESIDENT  
202 CENTURY SQUARE BLVD., SUGAR LAND, TEXAS 77478  
PH. (281) 500-6050

SURVEYORS: **GBI PARTNERS, L.P.** ENGINEER: **LJA Engineering, Inc.**

LAND SURVEYING CONSULTANTS  
15940 S. GESSNER RD., MISSOURI CITY, TX 77459  
PHONE: 281-459-4334 www.gbisurvey.com  
TBPLS FIRM # 10130300

1904 W. Grand Parkway North  
Suite 100  
Katy, Texas 77449  
Phone 713.953.5200  
Fax 713.953.5026  
FRN-F-1386

RESERVE	ACREAGE	SQ.FT.	TYPE	MAINTENANCE/OWNERSHIP
A	0.714	31,092	RESTRICTED TO LANDSCAPE	SIENNA PLANTATION MUNICIPAL UTILITY DISTRICT NO. 5
B	0.993	43,257	RESTRICTED TO LANDSCAPE	SIENNA PLANTATION MUNICIPAL UTILITY DISTRICT NO. 5
C	0.108	4,685	RESTRICTED TO LANDSCAPE	SIENNA PLANTATION MUNICIPAL UTILITY DISTRICT NO. 5
D	0.090	3,913	RESTRICTED TO DRAINAGE	SIENNA PLANTATION MUNICIPAL UTILITY DISTRICT NO. 4
E	0.953	41,531	RESTRICTED TO DRAINAGE	SIENNA PLANTATION MUNICIPAL UTILITY DISTRICT NO. 4
F	3.134	136,504	RESTRICTED TO LEVEE	SIENNA PLANTATION LEVEE IMPROVEMENT DISTRICT
TOTAL	5.992	260,982		