

Exhibit A

THE STATE OF TEXAS

§

COUNTY OF FORT BEND

§

REVOCABLE LICENSE AGREEMENT BETWEEN
FRATERNITY OF ONE, INC. AND FORT BEND COUNTY
FOR USE OF BALL FIELDS AT FREEDOM PARK

THIS LICENSE AGREEMENT is made and entered into by and between FORT BEND COUNTY, a body corporate and politic under the laws of the State of Texas, hereinafter referred to as "County," and FRATERNITY OF ONE, INC., a Texas non-profit Corporation, hereinafter referred to as "League."

I.

RECITALS

WHEREAS, Fort Bend County hereby adopts Chapter 320 of the Local Government Code for the purpose of acquiring, improving, equipping, maintaining, financing, and operating one or more public parks;

WHEREAS, Fort Bend County Commissioners Court elects to exercise and perform the powers authorized by Chapter 320 which includes executing a contract pertaining to a park under its control, namely Fort Bend County Freedom Park;

WHEREAS, FRATERNITY OF ONE, INC. ("League" or "FOI, Inc.") desires to assist Fort Bend County ("County") in providing recreational opportunities at Freedom Park for the citizens of the County, to promote the sport and hobby of baseball and develop within the citizens of the County the spirit of good sportsmanship and cooperation, as well as provide a means to actively and recreationally occupy the time and leisure of said citizens;

WHEREAS, League has requested permission to use and to make improvements to a certain portion of Freedom Park, for the purposes described above, to be used by persons residing in the County;

WHEREAS, the County is willing to allow League to use and to make improvements to a certain portion of Freedom Park for the purposes set forth above;

WHEREAS, League is willing to supervise and manage the said baseball fields and appurtenances thereto;

WHEREAS, County finds that this License serves a public purpose.

NOW THEREFORE, in consideration of the mutual covenants, licenses and benefits to both parties, it is agreed as follows:

08/31/2015 original returned to Lila @ Commissioner Pct 3

II.
TERMS

A. PROPERTY USE

1. Subject to the provisions of this license, the County hereby licenses to the League a revocable right to use, make improvements to and maintain the following described portion of Freedom Park, located in Fort Bend County, Texas, to-wit:

Those certain baseball fields located on a tract of land being a part of Fort Bend County Freedom Park, said area being identified with hatch lines as "FOI, Inc." on the map or diagram marked Exhibit "A," attached hereto and incorporated herein by reference as if copied herein verbatim, hereinafter called "Property."

2. The license granted herein permits League to use, schedule use of, maintain and improve the above described Property for the purposes of providing sporting activities and play fields for the residents of Fort Bend County and surrounding areas.
3. This license does not convey any interest in Property to League. The license is merely a license to use the Property according to the terms hereof.

B. TERM

The term of this license is one (1) year, beginning on August 25, 2015 and ending, unless terminated sooner pursuant to the terms hereof, on August 24, 2016. This license may be renewed for two (2) additional one (1) year terms, unless terminated as provided for in Section K of this Agreement.

C. NAME

The fields are to be known as "Freedom Park Baseball Fields."

D. MAINTENANCE

1. As consideration for the use of the fields, League shall provide for cleanup at the Property at the sole expense of League. Such cleanup shall include, but not be limited to removal of any graffiti and trash pickup. County will mow, edge and weed ball fields at least once per week. League may mow, edge and weed more often if desired.
2. League will keep the fields and that portion of the Property lying and being within twenty-five yards of the fields in a playable, neat, clean and respectable condition, maintenance of grounds, building, fences, playing areas, spectator areas and on-site sewage systems, if applicable.
3. League shall also keep and maintain in good repair, to the satisfaction of County, the Property and all improvements upon the Property, including but not limited to all seating, bleachers; concession stands; fences; sidewalks; landscaping; baseball fields; utility tie-ins; gas; water; sewer service lines; floodlighting; electrical outlets; press boxes; scoreboards; backstops; storage buildings and all

other fixtures and improvements for the fields in a safe, attractive and good state of repair and cleanliness.

4. League shall provide all supplies, materials and equipment necessary to perform the maintenance requirements described herein at the sole expense of the League.
5. County may perform periodic unannounced and/or noticed inspections of the fields and appurtenances thereto to determine the condition thereof. If County determines that the League is not complying with the provisions of this subparagraph, the County may terminate this license upon ten (10) days advance written notice to League.

E. CONCESSION SALES AND INCOME

1. League may sell "concession items" such as food, beverages, tournaments, activity "programs" and sponsored banner flags and scoreboards without need for prior approval from County.
2. League will obtain at its sole expense any and all necessary and/or required permissions and/or permits needed for the sale and preparation of concession food and beverage items.
3. League must have prior written approval from County regarding any other uses of the property for production of income not named herein.

F. IMPROVEMENTS

1. This License permits League to make improvements to Freedom Park which will enhance the use of the grounds for sporting purposes.
2. No work for improvements shall commence before County has approved construction plans which must be submitted to County no later than 60 days prior to beginning construction. Construction shall be in accordance with the plans presented.
3. League shall timely satisfy and discharge all debt for all material and labor for improvements made upon the Property. In the event that a lien for unpaid labor and/or materials is threatened or filed against the Property, League shall promptly cause the lien to be released and/or the threat be removed. The filing of a lien against the Property for unpaid material and/or labor brought to or performed upon the Property by or for the benefit of League constitutes an injury to the County and is cause for immediate termination of this license.
4. Any fixtures, improvements, alterations and additions thereto, made and/or installed in or upon the fields by League, including, but not limited to the playing areas, the appurtenances thereto, team quarters (including lockers and showers), public restrooms, electronic scoreboards, sidewalks, shrubberies, stands, floodlighting facilities, and any or all other fixtures and improvements (similar or dissimilar) immediately become the property of the County when installed and/or constructed upon the fields. Except as otherwise provided herein, all property that may be moved without damage to the Property, as determined solely by County, does not become the property of the County, but remains the property of the

League. Upon termination of this license, any movable property not removed by League before the date of termination becomes the property of the County.

G. UTILITIES

County shall pay 100% of the cost of the electricity bill for the Property.

H. LIABILITY AND INSURANCE

1. League shall furnish County with insurance certificates(s) and a copy of each policy that is in effect as of the effective date of this Agreement for verification and approval by the County Risk Management Department. Association shall provide County subsequent insurance certificates throughout the term of the Agreement upon request. Association shall carry General Liability insurance at minimum combined single limits of \$1,000,000 per-occurrence and \$2,000,000 general aggregate for bodily injury and property damage, which coverage shall include independent contractors, and contractual liability each at \$1,000,000 per occurrence. Coverages shall be written on per occurrence forms. Policies shall name the County, its elected and appointed officials, agents, and employees as additional insureds. The liability policy shall contain a waiver of subrogation in favor of County and members of Commissioners Court.
2. THE LEAGUE EXPRESSLY AGREES TO DEFEND, INDEMNIFY AND HOLD HARMLESS THE COUNTY FROM AND AGAINST ANY AND ALL LOSS, DAMAGE, CLAIMS, DEMANDS, LAWSUITS, LIABILITY, JUDGMENTS AND EXPENSES, INCLUDING ATTORNEY FEES, INVESTIGATIVE COSTS, AND OTHER COSTS OF LITIGATION, IN ANY MANNER ARISING OUT OF THE ACTS OR OMISSIONS OF THE LEAGUE AND THE LEAGUE'S EMPLOYEES, CONTRACTORS, REPRESENTATIVES, MEMBERS, AGENTS, GUESTS, INVITEES AND VOLUNTEERS, IN THEIR USE OF THE PROPERTY, IRRESPECTIVE OF WHETHER THE COUNTY WAS CONCURRENTLY NEGLIGENT.
3. League shall ensure that a "FORT BEND COUNTY ATHLETIC FACILITY RELEASE OF LIABILITY FOR PARTICIPANT" is executed on behalf of each League participant prior to participation, attached as Exhibit B to this Agreement. Copies of the Release of Liability will be made available to County upon request.
4. County makes no representation, warranty, or guarantee with respect to the condition of the Property, the presence or absence of pits or depressions in the surface of the fields, the type or condition of the soil or other material within the soil, and the presence of pipes or other objects in the soil. LEAGUE ACCEPTS THE PROPERTY AND ALL APPURTENANCES AND IMPROVEMENTS THERETO "AS IS, WHERE IS AND WITH ALL FAULTS."

I. CONDUCT/SECURITY

1. The League shall exercise proper supervision and control of all activities of the League on the Property. In exercising the rights and performing the obligations

required of it under the terms of this license, the League shall comply, and shall require all persons using the Property to comply, with all applicable federal, state, county and city laws, ordinances, rules and regulations, including the Park Rules that may be adopted from time to time by the Commissioners Court. Said Park Rules are incorporated herein by reference as if copied herein verbatim. Additionally, the League shall at all times maintain and enforce good order and fair sportsmanship upon the Property, and shall not permit any conduct, behavior or practice in violation of any federal, state, or municipal laws, rules, regulations or ordinances or of a sort likely to bring discredit or humiliation upon anyone, including Fort Bend County and its governing body.

2. The League shall permit all persons residing in Fort Bend County, Texas to participate in the activities of the League upon the Property. The League shall not discriminate against any person or persons because of race, color, religion, sex or national origin.
3. The League may and is encouraged to create and distribute to users of the Property a written guideline or code of conduct. The guideline or code of conduct may not conflict with any federal, state, county and/or city ordinance, rule and regulation. However, the League may require conduct of a higher standard or degree of character than is required under all rules and laws so long as the prescribed conduct does not discriminate against any person on the basis of their race, color, religion, sex or national origin. League shall provide to the County any such guideline or code of conduct.
4. The League shall provide all necessary security personnel for the events it sponsors or conducts on the Property.
5. The League acknowledges and agrees that is neither the responsibility nor the right of persons other than those representing Fort Bend County Parks and Recreation Department to enforce park rules and regulations. League shall contact Fort Bend County Parks & Recreation if any League participant witnesses a violation of Park Rules or actions inconsistent with expectations of a public setting. For emergency situations, League shall call the Fort Bend County Sheriff's Office for assistance.

J. TIMES /CALENDAR

1. County may establish the day-to-day times when the League may use the Property for its activities. The County may post signs at or near the entrance to the Property stating the times when the Property is open to the public and the League.
2. The League may use the Property at all times during the calendar year, except when the Property is scheduled for other events by the County.
3. Notwithstanding the foregoing, the County may alter or change the dates and times that the League may use the Property. The County may, with or without notice to the League, prohibit entry into and use of the Property whenever it is necessary, as determined by County. Unless an act of God, war or other public calamity requires closure of the Property, the County may give notice to the League, in the manner described herein of any change in the Park's calendar.

4. The League shall be required to provide a written schedule of games and practices for each athletic season. The League shall be responsible for scheduling use of the Property by other youth organizations. The League shall not deny the use of the Property to any youth organization that does not interfere with the normal League playing season.

K. NOTICE AND TERMINATION

1. This license may be terminated by either party, with or without cause, by giving written notice to the other party at least thirty (30) days prior to the date of termination.
2. Notice to County shall be given by registered or certified U. S. Mail, Return Receipt Requested, postage prepaid, addressed to Fort Bend County, County Judge, 401 Jackson St., Richmond, Texas 77469, with copy to Fort Bend County, Parks Director 9555A Highway 6 Missouri City, TX 77459.
3. Notice to League shall be given by registered or certified U. S. Mail, Return Receipt Requested, postage prepaid, addressed to Fraternity of One, Inc., 23102 Seven Meadows Parkway, Katy, Texas 77494.
4. Notice is considered given and completed upon deposit of the notice in the U.S. Mail.
5. Each party may change its respective address and specify as its address any other address in the State of Texas by giving at least fifteen (15) days written notice of such change to the other party.

L. MISCELLANEOUS

1. Paragraph captions herein are merely descriptive and do not add to or detract from the content of this license.
2. Any oral representations or modifications concerning this license are of no force or effect; and this license may be modified or changed only by the Commissioners Court.
3. League shall provide the County at all times with the current names, addresses and phone numbers of the President, chief acting officer, vice-president and each board member of League.
4. This license shall be governed under Texas law, and it shall be performed entirely in Fort Bend County, Texas.
5. The person signing this license on League's behalf hereby represents that he or she is authorized by the League's Board of Directors to execute this license on League's behalf.
6. No statement contained in this license shall be construed so as to find the League or any of its participants, to be an employee, or agent of the County, and the League and its participants shall be entitled to none of the rights, privileges, or benefits of County employees except as otherwise may be stated herein nor shall the League or its participants hold itself out as an employee or agent of the County.

7. In the event of one or more of the provisions contained in this license shall for any reason be held to be invalid, illegal or unenforceable in any respect, such invalidity, illegality, or unenforceability shall not affect any other provision hereof and this license shall be construed as if such invalid, illegal, or unenforceable provision had never been contained herein.
8. The waiver by either party of a breach of any provision of this license shall not operate as or be construed as a waiver of any subsequent breach.
9. Any amendments to this license shall be of no effect unless in writing and signed by both parties hereto.
10. League shall not assign this license, or any interest arising herein, without the prior written consent of County.

IN WITNESS WHEREOF, the parties hereto have signed to be effective on the 1st day of June, 2015.

FORT BEND COUNTY, TEXAS

By: *Robert E. Hebert*
 Robert E. Hebert, County Judge

ATTEST:

Date: August 25, 2015

Laura Richard
 Laura Richard, County Clerk

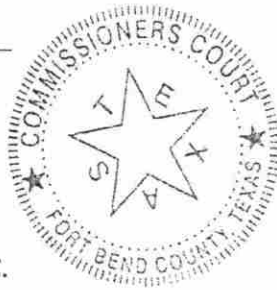

FRATERNITY OF ONE, INC.

By: *Nathan Dagley*
 Signature

Nathan Dagley DIRECTOR
 Printed Name and Title

Date: 8/25/2015

Exhibit A: Map
 Exhibit B: Participant Release Form

PMTR/agreements/precinct3 04.12.2013

Exhibit A MAP

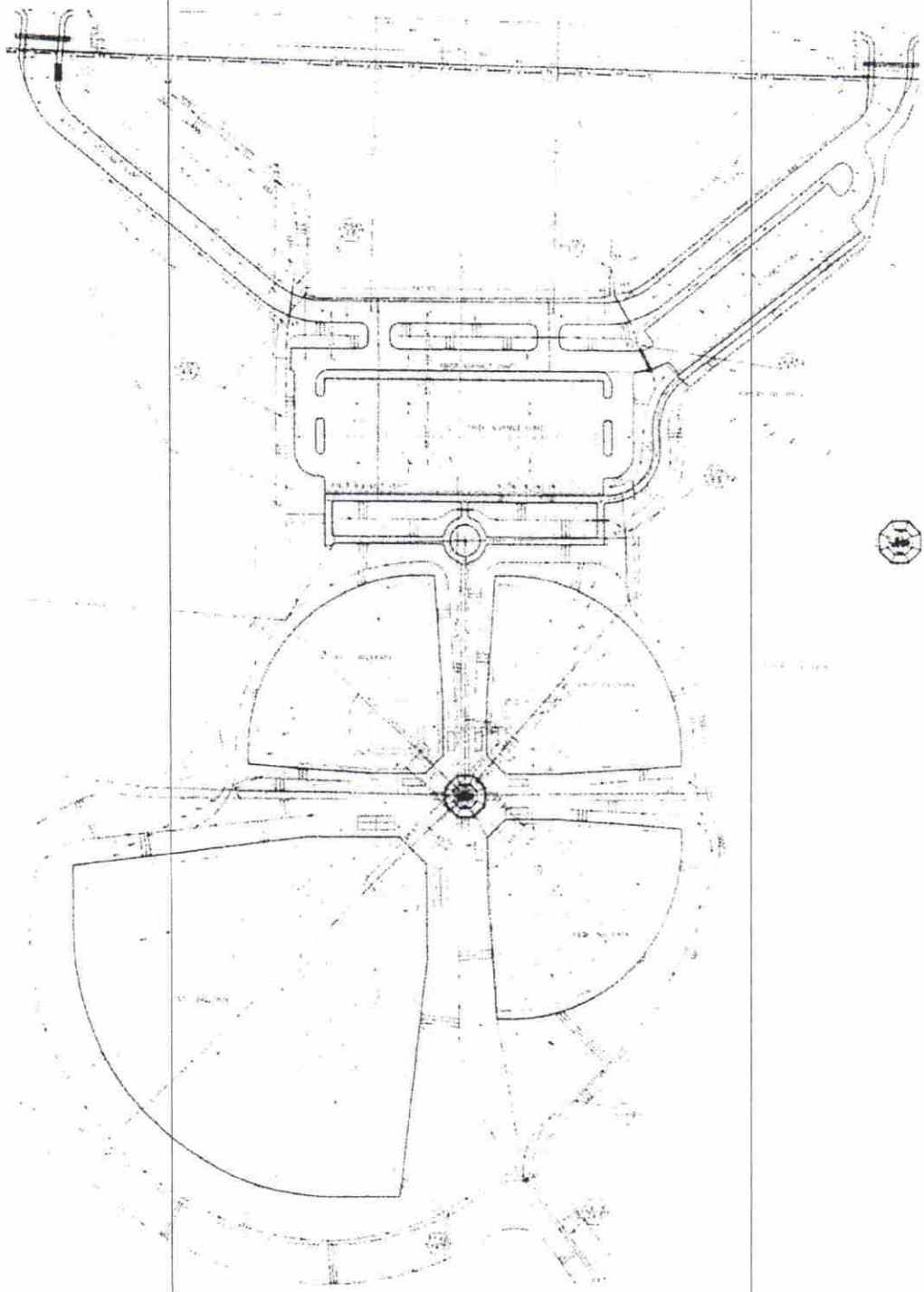

Exhibit B

