

REVIEW BY FORT BEND COUNTY COMMISSIONERS COURT

On this 4th day of October, 2016, Commissioners Court came on to be heard and reviewed the accompanying notice of Satterfield & Pontikes Construction, Inc. Job Location 1747 Waters Lake Boulevard, Missouri City, TX 77459 Date 9/7/2016 Bond No. 1141989, Permit No. 2016-9436 to make use of certain Fort Bend County property subject to, "A Revised Order Regulating the Laying, Construction, Maintenance, and Repair of Buried Cables, Conduits, and Pole Lines, In, Under, Across or Along Roads, Streets, Highways, and Drainage Ditches in Fort Bend County, Texas, Under the Jurisdiction of the Commissioners Court of Fort Bend County, Texas," as passed by the Commissioners Court of Fort Bend County, Texas, the 3rd day of August, 1987, recorded in Volume _____ of the Minutes of the Commissioners Court of Fort Bend County, Texas, to the extent that such order is not inconsistent with Article 1436a, Vernon's Texas Civil Statutes. Upon Motion of Commissioner _____, seconded by Commissioner _____, duly put and carried, it is ORDERED, ADJUDGED AND DECREED that said notice of said above purpose is hereby acknowledged by the Commissioners Court of Fort Bend County, Texas, and that said notice be placed on record according to the regulation order thereof.

Notes:

1. Evidence of review by the Commissioners Court must be kept on the job site and failure to do so constitutes grounds for job shutdown.
2. Written notices are required:
 - a. 48 hours in advance of construction start up, and
 - b. when construction is completed and ready for final inspection
 Mail notices to: Permit Administrator
 Fort Bend County Engineering
 301 Jackson Street
 Richmond, Texas 77469
 281-633-7500
3. This permit expires one (1) year from date of permit if construction has not commenced.

By: 
County Engineer

Presented to Commissioners Court and approved.
Recorded in Volume _____

By: N/A
Drainage District Engineer/Manager

Minutes of Commissioners Court

Clerk of Commissioners Court

By: _____
Deputy

**PERFORMANCE BOND COVERING ALL CABLE, CONDUIT AND/OR POLE LINE
ACTIVITY IN, UNDER, ACROSS OR ALONG FORT BEND COUNTY ROAD, COMMERCIAL
DRIVEWAY AND MEDIAN OPENINGS OR MODIFICATIONS**

AUTHORIZED

BOND NO. 1141989

THE STATE OF TEXAS §

KNOW ALL MEN BY THESE PRESENTS:

COUNTY OF FORT BEND §

THAT WE, Satterfield & Pontikes Construction, Inc. whose address is 11000 Equity Drive, Suite 100, Houston Texas, hereinafter called the Principal, And Arch Insurance Company, a Corporation existing under and by virtue of the laws of the state of MO and authorized to do an indemnifying business in the state of Texas, and whose principal office is located at 300 Plaza Three, Jersey City, NJ 07311, whose officer residing in the State of Texas, authorized to accept service in all suits and actions brought whining said state is CT Corporation System and Whose address is 1999 Bryan Street, Suite 900, Dallas, TX 75201-3136, hereinafter called the Surety, and held and firmly bound unto, Robert e. Hebert, County Judge of Fort Bend County, Texas, or his successors in office, in the full sum of Ten Thousand Dollars and no/100 Dollars (\$ 10,000.00) current, lawful money of the United States of America, to be paid to said Robert E. Hebert, County Judge of Fort Bend County, Texas, or his successors in office, to which payment well and truly to be made and done, we, the undersigned, bind ourselves and each of us, our heirs, executors, administrators, successors, assigns, and legal representatives, jointly and severally, by these presents.

THE CONDITION OF THIS BOND IS SUCH THAT, WHEREAS, the above bounden principal contemplates laying, constructing, maintaining and/or repairing one or more cables, conduits, and/or pole lines in, under, across and/or along roads, streets and highways, commercial driveway and median openings or modifications in the County of Fort Bend, and the State of Texas, under the jurisdiction of the Commissioners' Court of Fort Bend County, Texas, pursuant to the Commissioners' Court order adopted on the 1st day of December, A.D. 1980, recorded in Volume 13, of the Commissioners' Court Minutes of Fort Bend County, Texas, regulating same, which Commissioners' Court order is hereby referred to and made a part hereof for all purposes as though fully set out herein;

AND WHEREAS, the principal desires to provide Fort Bend County with a performance bond covering all such cable, conduit and/or pole line activity, commercial driveway and median openings or modifications;

NOW, THEREFORE, if the above bounden principal shall faithfully perform all its cable, conduit and/or pole line activity (including, but not limited to the laying, construction, maintenance and/or repair of cables, conduits and/or pole lines) in, under, across and/or along roads, streets and highways, commercial driveway and median openings or modifications in the County of Fort Bend and State of Texas, under the jurisdiction of the Commissioners Court of Fort Bend County, Texas, pursuant to and in accordance with minimum requirements and conditions of the above mentioned Commissioners' Court order set forth and specified to be by said principal done and performed, at the time and in the manner therein specified, and shall pay over and make good and reimburse Fort Bend County, all loss and damages which Fort Bend County may sustain by reason of any failure or default on the part of said principal, then this obligation shall be null and void, otherwise to remain in full force and effect.

This bond is payable at the County Courthouse in the County of Fort Bend and State of Texas.

It is understood that at any time Fort Bend County deems itself insecure under this bond, it may require further and/or additional bonds of the principal.

EXECUTED this 7th day of September, 2016.

Satterfield & Pontikes Construction, Inc.
PRINCIPAL

BY Denis Ducran, VP & General Counsel

Arch Insurance Company
SURETY

BY Kristi Lovett, Attorney In Fact

THIS POWER OF ATTORNEY IS NOT VALID UNLESS IT IS PRINTED ON BLUE BACKGROUND.

This Power of Attorney limits the acts of those named herein, and they have no authority to bind the Company except in the manner and to the extent herein stated. Not valid for Mortgage, Note, Loan, Letter of Credit, Bank Deposit, Currency Rate, Interest Rate or Residential Value Guarantees.

POWER OF ATTORNEY

Know All Persons By These Presents:

That the Arch Insurance Company, a corporation organized and existing under the laws of the State of Missouri, having its principal administrative office in Jersey City, New Jersey (hereinafter referred to as the "Company") does hereby appoint:

Ashley Britt, Barry K. McCord, Brett A. Tisdale, David G. Miclette, David T. Miclette, Edward G. Britt, Jr., Heather Noles, Joni Bowen, Kristi Lovett, Rita G. Gulizo, Robert C. Davis, Samuel F. Bowen, Susan D. Zapalowski and Tabitha Starkey of Houston, TX (EACH)

its true and lawful Attorney(s)-in-Fact, to make, execute, seal, and deliver from the date of issuance of this power for and on its behalf as surety, and as its act and deed:

Any and all bonds, undertakings, recognizances and other surety obligations, in the penal sum not exceeding Ninety Million Dollars (\$90,000,000.00).

This authority does not permit the same obligation to be split into two or more bonds In order to bring each such bond within the dollar limit of authority as set forth herein.

The execution of such bonds, undertakings, recognizances and other surety obligations in pursuance of these presents shall be as binding upon the said Company as fully and amply to all intents and purposes, as if the same had been duly executed and acknowledged by its regularly elected officers at its principal administrative office in Jersey City, New Jersey.

This Power of Attorney is executed by authority of resolutions adopted by unanimous consent of the Board of Directors of the Company on September 15, 2011, true and accurate copies of which are hereinafter set forth and are hereby certified to by the undersigned Secretary as being in full force and effect:

"VOTED, That the Chairman of the Board, the President, or the Executive Vice President, or any Senior Vice President, of the Surety Business Division, or their appointees designated in writing and filed with the Secretary, or the Secretary shall have the power and authority to appoint agents and attorneys-in-fact, and to authorize them subject to the limitations set forth in their respective powers of attorney, to execute on behalf of the Company, and attach the seal of the Company thereto, bonds, undertakings, recognizances and other surety obligations obligatory in the nature thereof, and any such officers of the Company may appoint agents for acceptance of process."

This Power of Attorney is signed, sealed and certified by facsimile under and by authority of the following resolution adopted by the unanimous consent of the Board of Directors of the Company on September 15, 2011:

VOTED, That the signature of the Chairman of the Board, the President, or the Executive Vice President, or any Senior Vice President, of the Surety Business Division, or their appointees designated in writing and filed with the Secretary, and the signature of the Secretary, the seal of the Company, and certifications by the Secretary, may be affixed by facsimile on any power of attorney or bond executed pursuant to the resolution adopted by the Board of Directors on September 15, 2011, and any such power so executed, sealed and certified with respect to any bond or undertaking to which it is attached, shall continue to be valid and binding upon the Company.

In Testimony Whereof, the Company has caused this instrument to be signed and its corporate seal to be affixed by their authorized officers, this 28th day of July, 2016.

Attested and Certified

Arch Insurance Company

Patrick K. Nails
Patrick K. Nails, Secretary



David M. Finkelstein
David M. Finkelstein, Executive Vice President

STATE OF PENNSYLVANIA SS

COUNTY OF PHILADELPHIA SS

I, Helen Szafran, a Notary Public, do hereby certify that Patrick K. Nails and David M. Finkelstein personally known to me to be the same persons whose names are respectively as Secretary and Executive Vice President of the Arch Insurance Company, a Corporation organized and existing under the laws of the State of Missouri, subscribed to the foregoing instrument, appeared before me this day in person and severally acknowledged that they being thereunto duly authorized signed, sealed with the corporate seal and delivered the said instrument as the free and voluntary act of said corporation and as their own free and voluntary acts for the uses and purposes therein set forth.

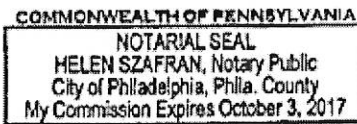

Helen Szafran
Helen Szafran, Notary Public
My commission expires 10/03/2017

CERTIFICATION

I, Patrick K. Nails, Secretary of the Arch Insurance Company, do hereby certify that the attached Power of Attorney dated July 28, 2016 on behalf of the person(s) as listed above is a true and correct copy and that the same has been in full force and effect since the date thereof and is in full force and effect on the date of this certificate; and I do further certify that the said David M. Finkelstein, who executed the Power of Attorney as Executive Vice President, was on the date of execution of the attached Power of Attorney the duly elected Executive Vice President of the Arch Insurance Company.

IN TESTIMONY WHEREOF, I have hereunto subscribed my name and affixed the corporate seal of the Arch Insurance Company on this 7th day of September, 2016.

Patrick K. Nails
Patrick K. Nails, Secretary

This Power of Attorney limits the acts of those named therein to the bonds and undertakings specifically named therein and they have no authority to bind the Company except in the manner and to the extent herein stated.

PLEASE SEND ALL CLAIM INQUIRIES RELATING TO THIS BOND TO THE FOLLOWING ADDRESS:

Arch Insurance – Surety Division
3 Parkway, Suite 1500
Philadelphia, PA 19102



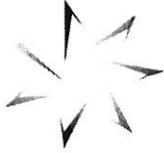

ARCH Insurance Company

ARCH Surety

TEXAS CONSUMER NOTICE

IMPORTANT NOTICE

To obtain information or make a complaint:

You may contact your agent at the telephone number provided on the Declarations page of your policy.

You may contact William J. Misero, Surety, Arch Insurance Company, at the toll-free telephone number or address provided below:

**Arch Insurance Company
Attention: William J. Misero
3 Parkway Suite 1500
Philadelphia PA 19102
1-866-472-8845**

You may contact the Texas Department of Insurance to obtain information on companies' coverages, rights or complaints at:

1-800-252-3439

You may write the Texas Department of Insurance:

**P.O. Box 149091
Austin, TX. 78714-9091
FAX# (512) 475-1771**

PREMIUM OR CLAIM DISPUTES:

Should you have a dispute concerning your premium or about a claim you should contact the agent or the company first. If the dispute is not resolved, you may contact the Texas Department of Insurance.

ATTACH THIS NOTICE TO YOUR POLICY:

This notice is for information only and does not become a part or condition of the attached document.

FORT BEND INDEPENDENT SCHOOL DISTRICT PROPOSED PRIVATE SANITARY SEWER, WATER LINE, STORM SEWER, AND GRADING TO SERVE ELEMENTARY SCHOOL #48 AT SIENNA SOUTH

1757 WATERS LAKE BLVD.,
MISSOURI CITY, TEXAS

JUNE 2016

BOARD OF TRUSTEES

DAVE JAMES PRESIDENT	DAVE ROSENTHAL VICE PRESIDENT
KRISTIN YASSIN SECRETARY	JASON BUDRINE MEMBER
JASON BUDRINE MEMBER	JIM RICE MEMBER
JIM RICE MEMBER	CHARLES E. DUPRE, Esq. SUPERINTENDENT

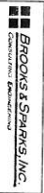

2100 WEST 19TH STREET, SUITE 100
MISSOURI CITY, TEXAS 77058
TEL: (281) 592-4444
FAX: (281) 592-4444

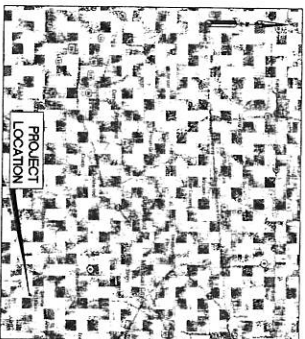
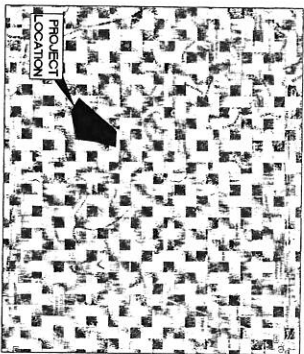

LOCATION MAP
N 135

KEY MAP No. 6501

INDEX

SHEET NO.	DESCRIPTION
00	COVER SHEET
01	GENERAL NOTES
02	TOPOGRAPHIC SURVEY
03	GRADING PLAN
04	STORM SEWER PLAN
05	DRAINAGE AREA MAP
06	DRAINAGE AREA CALCULATIONS
07	WATER AND SANITARY SEWER PLAN
08	STORM WATER POLLUTION PREVENTION PLAN
09	STORM SEWER DETAILS
10	SANITARY SEWER DETAILS
11	WATER DETAILS
12	STORM WATER POLLUTION PREVENTION PLAN DETAILS
13	OUTFALL DETAILS

EXCEL BEND COUNTY SIGNATURE BLOCK	
EXAMINER: FOR: RICHARD W. STEWART, P.E.	DATE: 7/5/16
THESE SIGNATURES ARE VOID IF CONSTRUCTION HAS NOT COMMENCED IN (1) YEAR FROM DATE OF APPROVAL.	
APPROVED: <i>Michael...</i>	DATE: 9/12/16
DEVELOPMENT COORDINATOR	

ADDITIONAL OF PRE-CONSTRUCTION MEETING AND ALL PAVING ACTIVITIES.
DATE: CONSTRUCTIONSTART/END/COMPLETION/

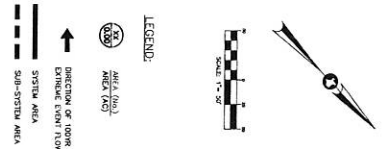

FORT BEND COUNTY SIGNATURE BLOCK
 APPROVED: *[Signature]*
 FORT BEND COUNTY
 ENGINEERING DEPARTMENT
 DATE: 9/2/16

C5	DRAINAGE AREA MAP	PROJECT NO: 201521 PREPARED BY: 16-ADW/NG DATE: 1/28/16 DRAWN: DSC CHECKED: SPG DATE: 03/22/2016 ISSUED FOR BIDDING: 03/22/2016 ISSUED FOR PERMIT: 03/22/2016 MODIFIED COMMENTS: 03/22/2016
		TEXAS - IBI GROUP 4515 East MacArthur Center Boulevard - Suite 300 Houston, Texas 77056 P: 281.291.8500 F: 281.291.8505 www.ibigroup.com

**CONSTRUCTION OF NEW
 ELEMENTARY SCHOOL # 48 (BP 3)
 AT SIENNA SOUTH**

FORT BEND INDEPENDENT SCHOOL DISTRICT
 Walters Lake Blvd., Missouri City, TX

CONSULTANTS

Soil Engineer
 IBI Group, Inc.
 4515 East MacArthur Center Boulevard, Suite 300
 Houston, Texas 77056
 P: 281.291.8500
 F: 281.291.8505
 www.ibigroup.com

Site Engineer
 IBI Group, Inc.
 4515 East MacArthur Center Boulevard, Suite 300
 Houston, Texas 77056
 P: 281.291.8500
 F: 281.291.8505
 www.ibigroup.com

Professional Engineer
 IBI Group, Inc.
 4515 East MacArthur Center Boulevard, Suite 300
 Houston, Texas 77056
 P: 281.291.8500
 F: 281.291.8505
 www.ibigroup.com

Professional Engineer
 IBI Group, Inc.
 4515 East MacArthur Center Boulevard, Suite 300
 Houston, Texas 77056
 P: 281.291.8500
 F: 281.291.8505
 www.ibigroup.com

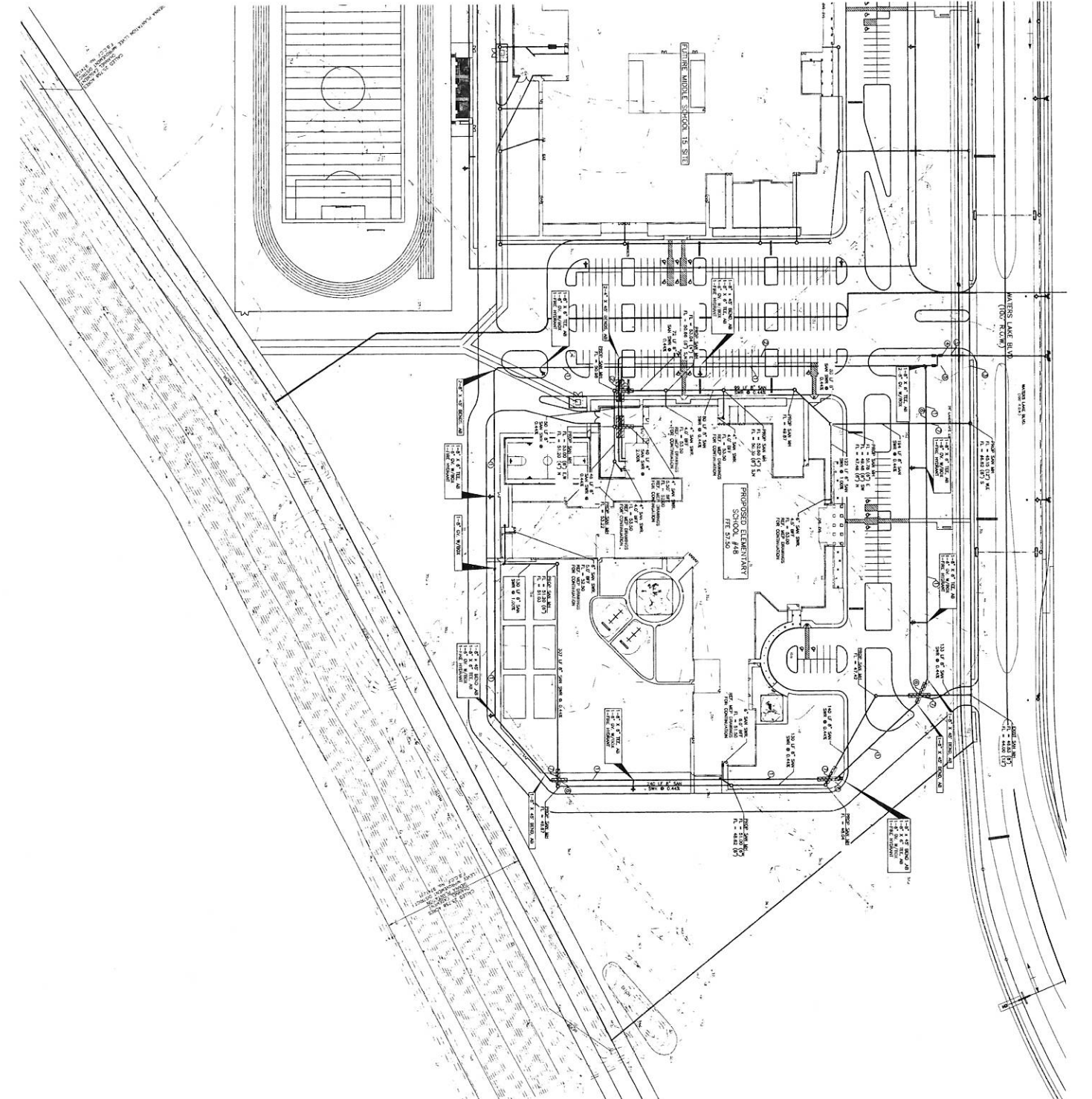

- LEGEND**
- PROPOSED MANHOLE
 - PROPOSED CLEANOUT
 - ◇ PROPOSED FIRE HYDRANT
 - ◇ PROPOSED GATE VALVE
 - ◇ PROPOSED TEAM
 - FLOW LINE
 - DIRECTION OF FLOW

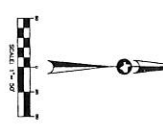

DESIGN NOTES:

1. EXISTING UTILITY UTILITIES SHOWN ARE NOT GUARANTEED TO BE CORRECT OR COMPLETE. FIELD SURVEY TO VERIFY ALL UNDERGROUND UTILITIES IN THE FIELD PRIOR TO CONSTRUCTION.
2. THE LOCATION OF ALL UTILITIES SHOWN ON THESE PLANS IS BASED ON THE FIELD SURVEY. THE CONTRACTOR SHALL BE RESPONSIBLE FOR VERIFYING THE LOCATION OF ALL UTILITIES PRIOR TO CONSTRUCTION. VERIFY ALL UTILITIES PRIOR TO CONSTRUCTION.
3. ALL EXISTING CONDUIT OR CABLE SHALL BE PROTECTED BY A MINIMUM OF 18" OF CONCRETE OR 12" OF SAND AND GRAVEL. THE CONNECTION TO ANY EXISTING PUBLIC WATERLINE SHALL BE MADE IN ACCORDANCE WITH THE BUREAU OF PUBLIC WORKS (BPW) STANDARDS. ALL CONNECTIONS SHALL BE MADE BY THE DESIGNER'S OFFICE AND AT THE CONTRACTOR'S EXPENSE.
4. ALL EXISTING CONDUIT OR CABLE SHALL BE PROTECTED BY A MINIMUM OF 18" OF CONCRETE OR 12" OF SAND AND GRAVEL. THE CONNECTION TO ANY EXISTING PUBLIC WATERLINE SHALL BE MADE IN ACCORDANCE WITH THE BUREAU OF PUBLIC WORKS (BPW) STANDARDS. ALL CONNECTIONS SHALL BE MADE BY THE DESIGNER'S OFFICE AND AT THE CONTRACTOR'S EXPENSE.
5. CONDUIT SHALL BE INSTALLED IN ACCORDANCE WITH THE BUREAU OF PUBLIC WORKS (BPW) STANDARDS. ALL CONNECTIONS SHALL BE MADE BY THE DESIGNER'S OFFICE AND AT THE CONTRACTOR'S EXPENSE.
6. CONDUIT SHALL BE INSTALLED IN ACCORDANCE WITH THE BUREAU OF PUBLIC WORKS (BPW) STANDARDS. ALL CONNECTIONS SHALL BE MADE BY THE DESIGNER'S OFFICE AND AT THE CONTRACTOR'S EXPENSE.
7. CONDUIT SHALL BE INSTALLED IN ACCORDANCE WITH THE BUREAU OF PUBLIC WORKS (BPW) STANDARDS. ALL CONNECTIONS SHALL BE MADE BY THE DESIGNER'S OFFICE AND AT THE CONTRACTOR'S EXPENSE.
8. CONDUIT SHALL BE INSTALLED IN ACCORDANCE WITH THE BUREAU OF PUBLIC WORKS (BPW) STANDARDS. ALL CONNECTIONS SHALL BE MADE BY THE DESIGNER'S OFFICE AND AT THE CONTRACTOR'S EXPENSE.
9. CONDUIT SHALL BE INSTALLED IN ACCORDANCE WITH THE BUREAU OF PUBLIC WORKS (BPW) STANDARDS. ALL CONNECTIONS SHALL BE MADE BY THE DESIGNER'S OFFICE AND AT THE CONTRACTOR'S EXPENSE.
10. CONDUIT SHALL BE INSTALLED IN ACCORDANCE WITH THE BUREAU OF PUBLIC WORKS (BPW) STANDARDS. ALL CONNECTIONS SHALL BE MADE BY THE DESIGNER'S OFFICE AND AT THE CONTRACTOR'S EXPENSE.

APPROVED: *[Signature]*
 FORT BEND COUNTY ENGINEER
 DATE: 9/21/16

PROJECT NO. 201521
 FRISD CSP# 15-047WGS
 DATE: June 01, 2015
 DRAWN: DSC
 CHECKED: SHC
 DATE: 08/24/2016
 ISSUED FOR PERMIT: 08/24/2016
 ADDED TO BUREAU: 08/24/2016
 MULTIPIC COMMENTS:

TEXAS - IBI GROUP
 440 East Main Street, Suite 200
 Austin, Texas 78701
 Tel: 512.476.1000
 Fax: 512.476.1001
 www.ibigroup.com

**CONSTRUCTION OF NEW
 ELEMENTARY SCHOOL # 48 (BP 3)
 AT SIENNA SOUTH**
 FORT BEND INDEPENDENT SCHOOL DISTRICT
 Waters Lake Blvd., Missouri City, TX

CONSULTANTS

ASA Daily
 10000 Katy Road, Suite 100
 Houston, Texas 77055
 Tel: 281.466.1111
 Fax: 281.466.1112
 www.asadaily.com

Li-Ting Yang, PE, Engineer
 10000 Katy Road, Suite 100
 Houston, Texas 77055
 Tel: 281.466.1111
 Fax: 281.466.1112
 www.asadaily.com

Stinson and Spaul, Inc.
 10000 Katy Road, Suite 100
 Houston, Texas 77055
 Tel: 281.466.1111
 Fax: 281.466.1112
 www.stinsonandspaul.com

FLM Design, Inc.
 10000 Katy Road, Suite 100
 Houston, Texas 77055
 Tel: 281.466.1111
 Fax: 281.466.1112
 www.flmdesign.com

Landmark Architect
 10000 Katy Road, Suite 100
 Houston, Texas 77055
 Tel: 281.466.1111
 Fax: 281.466.1112
 www.landmarkarchitect.com

C7

WATER & SANITARY PLAN



- GENERAL NOTES:**
1. ALL UTILITIES SHOWN ON THIS PLAN ARE NOT TO BE MOVED OR DELETED UNLESS SPECIFICALLY NOTED OTHERWISE.
 2. CONSTRUCTION SHALL BE IN ACCORDANCE WITH THE LATEST EDITIONS OF THE TEXAS CONSTRUCTION CODES AND RULES.
 3. THE LOCATION OF ALL UTILITIES SHOWN ON THIS PLAN IS BASED ON RECORD DRAWINGS AND FIELD SURVEY DATA. THE CONTRACTOR SHALL VERIFY THE LOCATION OF ALL UTILITIES PRIOR TO CONSTRUCTION.
 4. ALL EXISTING CONCRETE ON AERIAL PAVEMENT SHALL BE REPAIRED OR REPLACED WITH CONCRETE.

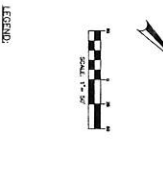
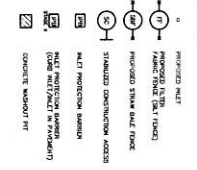

FORT BEND COUNTY SQUARE BLOCK
 APPROVED: *[Signature]* 9/12/16
 DEVELOPMENT COORDINATOR DATE

C8	SWPPP
	SWPPP

IBI

TEXAS - IBI GROUP

495 East Loop West, Suite 1000
 P.O. Box 1000, Houston, TX 77269-1000
 Tel: 281.410.1000
 www.ibigroup.com

PROJECT NO: 201521
 TEAM CHIEF: IBI GROUP
 DESIGN: IBI GROUP
 CHECKED: IBI GROUP
 DATE: 08/01/2016

ISSUED FOR BIDDING
 08/01/2016
 REVISIONS:
 08/02/2016
 08/02/2016

**CONSTRUCTION OF NEW
 ELEMENTARY SCHOOL # 48 (BP 3)
 AT SIENNA SOUTH**

FORT BEND INDEPENDENT SCHOOL DISTRICT
 Waters Lake Blvd., Missouri City, TX

CONSULTANTS	
<p>Structural IBI Group, Inc. 495 East Loop West, Suite 1000 P.O. Box 1000, Houston, TX 77269-1000 Tel: 281.410.1000 www.ibigroup.com</p> <p>MEP IBI Group, Inc. 495 East Loop West, Suite 1000 P.O. Box 1000, Houston, TX 77269-1000 Tel: 281.410.1000 www.ibigroup.com</p> <p>Electrical IBI Group, Inc. 495 East Loop West, Suite 1000 P.O. Box 1000, Houston, TX 77269-1000 Tel: 281.410.1000 www.ibigroup.com</p> <p>Interior Design IBI Group, Inc. 495 East Loop West, Suite 1000 P.O. Box 1000, Houston, TX 77269-1000 Tel: 281.410.1000 www.ibigroup.com</p> <p>Landscaping IBI Group, Inc. 495 East Loop West, Suite 1000 P.O. Box 1000, Houston, TX 77269-1000 Tel: 281.410.1000 www.ibigroup.com</p>	<p>Architect IBI Group, Inc. 495 East Loop West, Suite 1000 P.O. Box 1000, Houston, TX 77269-1000 Tel: 281.410.1000 www.ibigroup.com</p> <p>General Contractor IBI Group, Inc. 495 East Loop West, Suite 1000 P.O. Box 1000, Houston, TX 77269-1000 Tel: 281.410.1000 www.ibigroup.com</p> <p>Construction Management IBI Group, Inc. 495 East Loop West, Suite 1000 P.O. Box 1000, Houston, TX 77269-1000 Tel: 281.410.1000 www.ibigroup.com</p>

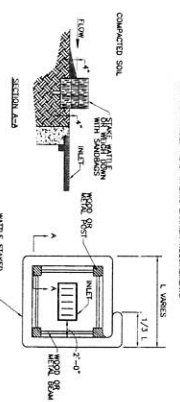
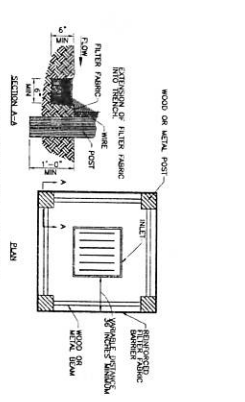

NOTE:
PROTECTIVE LINERBARS:
SYMBOL: [Symbol]

INLET PROTECTION BARRIERS FOR STAGE I INLETS
N.T.S.

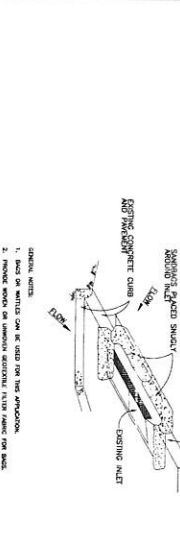
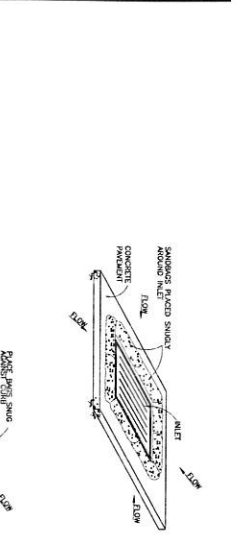

NOTE:
PROTECTIVE LINERBARS:
SYMBOL: [Symbol]

INLET PROTECTION BARRIERS FOR STAGE II INLETS
N.T.S.

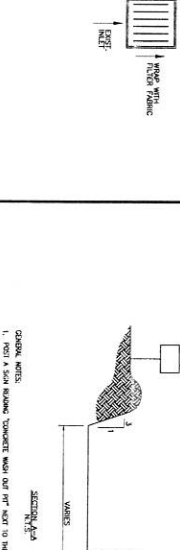
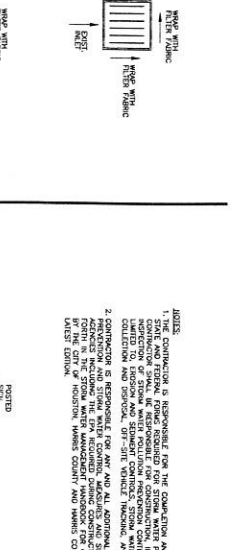

NOTE:
PROTECTIVE LINERBARS:
SYMBOL: [Symbol]

CONCRETE TRUCK WASH OUT AREA
N.T.S.

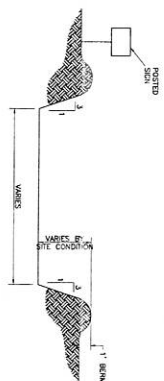

NOTE:
PROTECTIVE LINERBARS:
SYMBOL: [Symbol]

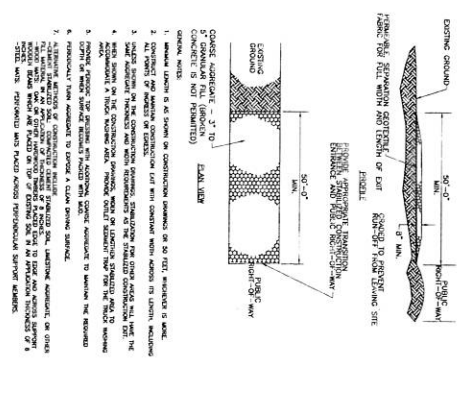

SYMBOL: [Symbol]

STABILIZED CONSTRUCTION ACCESS
N.T.S.

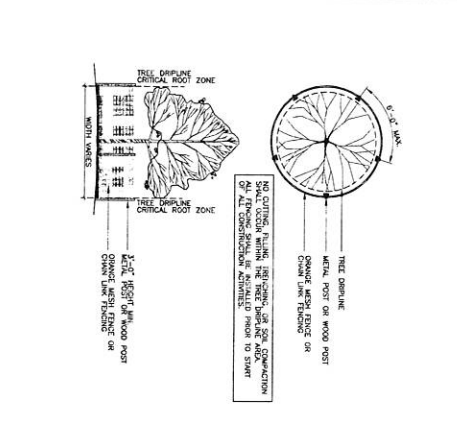

SYMBOL: [Symbol]

TREE PROTECTION DETAIL
N.T.S.

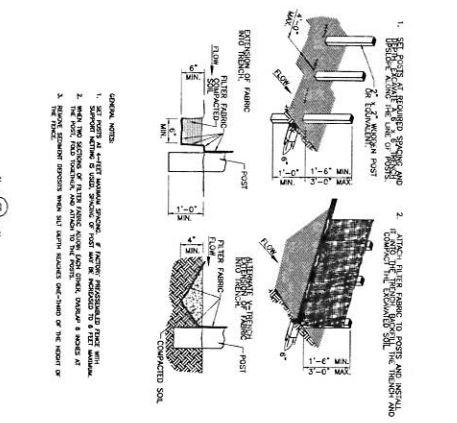

SYMBOL: [Symbol]

FILTER FABRIC FENCE
N.T.S.

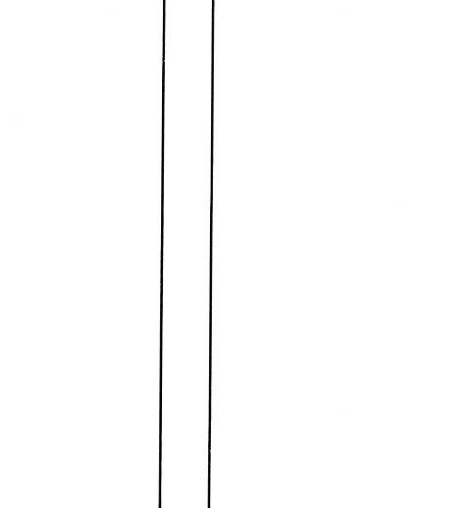

SYMBOL: [Symbol]

FOR SIGN CURB SQUARE BLOCK
APPROVED: [Signature]
DEVELOPMENT COORDINATOR

PROJECT NO. 201821	ISSUE
TITLE: SWPPP	ISSUED FOR RECORD
DATE: JUNE 01, 2018	POSTED SET ISSUES
CHECKED: SPC	DATE: 06/01/2018
DATE: 06/01/2018	ADDITIONAL COMMENTS

IBI
TEXAS - IBI GROUP
4401 W. LOOP SOUTH, SUITE 100
HOUSTON, TEXAS 77056
P.O. BOX 1000, HOUSTON, TX 77258
TEL: 281.416.4600
WWW.IBI.COM

CONSTRUCTION OF NEW ELEMENTARY SCHOOL # 48 (BP 3) AT SIENNA SOUTH
FORT BEND INDEPENDENT SCHOOL DISTRICT
Waters Lake Blvd., Missouri City, TX

CONTRACT NO.	DATE
PROJECT NO.	DATE
ISSUE	DATE
ISSUED FOR RECORD	DATE
POSTED SET ISSUES	DATE
ADDITIONAL COMMENTS	DATE

